

# HEWLETT-PACKARD

DON SOUTHWICK

**Personal Printer**

**ThinkJet**

Service Manual



---

# HP 2225 Series ThinkJet Printer Service Manual

---



**Manual Part Number**  
02225-90079

**HP Computer Museum**  
**[www.hpmuseum.net](http://www.hpmuseum.net)**

**For research and education purposes only.**

---

## Notice

The information contained in this document is subject to change without notice.

**Hewlett-Packard makes no warranty of any kind with regard to this material, including, but not limited to, the implied warranties of merchantability and fitness for a particular purpose. Hewlett-Packard shall not be liable for errors contained herein or for incidental or consequential damages in connection with the furnishing, performance, or use of this material.**

Hewlett-Packard assumes no responsibility for the use or reliability of its software on equipment that is not furnished by Hewlett-Packard.

This document contains proprietary information which is protected by copyright. All rights are reserved. No part of this document may be photocopied, reproduced, or translated to another program language without the prior written consent of Hewlett-Packard Company.

---

## Printing History

Edition 1	3/84
Edition 2	3/85
Edition 3	11/86

---

## Service Manual Symbols

There are three flags used throughout this manual that must be followed to ensure your safety and safety of the product. Text relating to the flag is directly to the right of the symbol. Be sure to pay special attention to the following symbols:

**Warning** 

---

The warning symbol will be used where potential danger to an individual may occur.

---

**Caution** 

---

The caution symbol will be used where potential danger to equipment may occur.

---

**Note** 

---

The note symbol will be used where attention to special instructions appear.

---



# Table of Contents

---

## Chapter 1:

### Product Information

- 1-1 Introduction
- 1-2 Manual Overview
- 1-3 Chapter 1 Overview
- 1-4 Accessories
- 1-6 Product Specifications
  - 1-6 Product Capabilities
  - 1-7 Interface
- 1-8 Getting Acquainted
  - 1-8 HP ThinkJet Printer Part Identification
  - 1-9 ThinkJet Identification by Backpanel
  - 1-11 Keypad Lights and Keys
    - 1-11 PWR Light
    - 1-11 Yellow Light
    - 1-12 Line Feed (LF) Key
    - 1-12 Form Feed (FF) Key
    - 1-12 Blue Key
  - 1-13 Battery Pack Information
    - 1-13 Battery Characteristics
    - 1-14 Signs of Battery Degradation
  - 1-14 Test Equipment and Tools

---

## Chapter 2:

### Site Planning and Requirements

- 2-1 Introduction
- 2-1 Physical Specifications
- 2-2 Electrical Specifications
- 2-3 Environmental Specifications

---

## Chapter 3:

### Installation and Configuration

- 3-1 Introduction
- 3-1 Items Included
- 3-2 ThinkJet Power Information
  - 3-2 HP 2225A & 2225D Fuses and Voltage
    - 3-2 Setting the Voltage
    - 3-3 Installing/Replacing the Fuse
  - 3-3 HP 2225B & 2225P Fuses and Voltage
  - 3-4 HP 2225C Fuses and Voltage
- 3-4 Loading Paper and Installing the Print Cartridge
  - 3-4 Loading Z-Fold Paper
  - 3-5 Installing the Print Cartridge
  - 3-6 Run the Self-Test
- 3-6 ThinkJet DIP Switches
  - 3-6 HP 2225A Address Select Switches
  - 3-8 HP 2225C, 2225D, & 2225P Mode Select Switches
  - 3-9 HP 2225D RS-232C Control DIP Switches

---

**Chapter 4:****Maintenance**

- 4-1 Introduction
  - 4-1 Maintenance Philosophy
  - 4-2 Print Cartridge Maintenance
  - 4-3 Multiple Print Cartridge Failures
  - 4-4 Cleaning
- 

**Chapter 5:****Functional Description**

- 5-1 Introduction
- 5-1 Microprocessor
- 5-2 Power Supply
  - 5-2 HP 2225A & 2225D
  - 5-3 HP 2225B & 2225P
  - 5-3 Battery Pack
  - 5-3 Boost Converter
  - 5-3 HP 2225C
- 5-4 Print Head Drive Logic
- 5-4 Stepper Motor Drive
  - 5-4 HP 2225A & 2225D
  - 5-5 HP 2225B & 2225P
  - 5-5 HP 2225C
- 5-6 Keypad
- 5-6 Home Switch Assembly
- 5-6 Backpanel
- 5-7 Reset
  - 5-7 HP 2225A & 2225D
  - 5-7 HP 2225B & 2225P
  - 5-7 HP 2225C
- 5-8 HP 2225A HP-IB I/O
- 5-8 HP 2225B HP-IL I/O
- 5-9 HP 2225C & 2225P Centronics I/O
- 5-11 HP 2225D RS-232C I/O
  - 5-11 DTR (Data Terminal Ready)
  - 5-12 XON/XOFF
  - 5-12 Serial Pin-out Information
- 5-13 Print Mechanism
  - 5-13 Paper Advance
  - 5-14 Carriage Drive
  - 5-14 Paper Path
  - 5-14 Heat Dissipation



---

**Chapter 6: Removal and Replacement**

- 6-1 Introduction
- 6-2 Top Cover (6.A)
- 6-2 Mechanism (6.B)
- 6-3 2225A PCAs (6.C)
- 6-3 2225B PCA (6.D)
- 6-4 2225C PCA (6.E)
- 6-4 2225D PCAs (6.F)
- 6-5 2225P PCAs (6.G)
- 6-6 Mechanism Assembly Removal Procedures
- 6-6 Grit Wheel & Tractor Pinwheels (6.H)
- 6-7 Carriage Assembly (6.I)
- 6-8 Bail Assembly (6.J)
- 6-10 Pinch Roller (6.K)
- 6-11 Home & Out of Paper Switches (6.L)

---

**Chapter 7: Adjustments**

- 7-1 Introduction
- 7-1 Bail Arm Adjustment
- 7-2 Power Supply
- 7-2 HP 2225A & 2225D
- 7-3 HP 2225B, 2225C, & 2225P

---

**Chapter 8: Troubleshooting**

- 8-1 Introduction
- 8-1 Self Tests
- 8-1 Nonprinting Self Test
- 8-2 Printing Self Test
- 8-4 Overall Troubleshooting
- 8-6 Main Logic PCA Troubleshooting
- 8-8 Troubleshooting the Kernel
- 8-9 Troubleshooting the Carriage Motor Circuitry
- 8-12 Troubleshooting the Home Switch Circuitry
- 8-14 Troubleshooting the Print Head Circuitry
- 8-15 Battery Pack Troubleshooting
- 8-16 Battery Pack Hysteresis
- 8-17 Troubleshooting Hints

---

**Chapter 9:****Replaceable Parts**

- 9-1 Introduction
- 9-1 Ordering Information
- 9-2 HP 2225A Overall
- 9-4 HP 2225A Main Logic PCA
- 9-6 HP 2225A I/O PCA
- 9-8 HP 2225B Overall
- 9-10 HP 2225B PCA
- 9-12 HP 2225C Overall
- 9-14 HP 2225C PCA
- 9-16 HP 2225D Overall
- 9-18 HP 2225D Main Logic PCA
- 9-20 HP 2225D I/O PCA
- 9-22 HP 2225P Overall
- 9-24 HP 2225P Main Logic PCA
- 9-26 HP 2225P I/O PCA
- 9-28 Mechanism

---

**Chapter 10:****Reference**

- 10-1 Documentation Summary
- 10-1 IBM/Epson Control Codes
- 10-3 HP PCL Control Codes

---

**Chapter 11:****Product History**

- 11-1 Introduction
- 11-2 Bail Arm Adjustment
- 11-4 Earlier Version 2225C Printers

---

**Chapter 12:****Diagrams**

# 1

## Product Information

---

### Introduction

This manual contains information necessary for maintenance and repair of the following HP ThinkJet printers:

- HP 2225A (HP-IB interface)
- HP 2225B (Battery powered HP-IL interface)
- HP 2225C (Centronics interface)
- HP 2225D (RS-232C Serial interface)
- HP 2225P (Battery powered Centronics interface)

The HP 2225C, explained in this manual, is a new version Centronics ThinkJet printer. The new version can be identified by the model number on the backpanel or bottom label. If your model number is "2225C+", 2225C information throughout this manual directly applies to your printer. If a "+" does not follow the 2225C model number, see chapter 11, Product History, to apply earlier version Centronics ThinkJet printers to this manual.



Figure 1-1. HP ThinkJet Printer.

The HP ThinkJet is a thermal inkjet printer with quiet 150 cps printing. A disposable print head cartridge contains enough ink to print approximately 500 pages. Programming and operating information can be found in their respective HP ThinkJet Owner's Manuals. See Table 1-1, HP ThinkJet Accessories, for the Owner's Manual part numbers.

---

## Manual Overview

The HP ThinkJet Printer Service Manual consists of the following information:

**Chapter 1: General Information.** Identifies the HP ThinkJet printers. This chapter lists accessories, capabilities, recommended tools, and a section explaining the printer's operator controls. There is also a section providing information regarding the HP 2225B and 2225P battery pack.

**Chapter 2: Site Planning and Requirements.** Defines the site operating requirements by listing the printer's physical, electrical, and environmental specifications.

**Chapter 3: Installation and Configuration.** Provides information for installing, configuring, and verifying proper printer operation.

**Chapter 4: Preventive Maintenance.** Contains information on print cartridge maintenance and printer cleaning.

**Chapter 5: Functional Description.** Provides a brief component description of the HP ThinkJet printers.

**Chapter 6: Removal and Replacement.** Contains procedures to remove and replace HP ThinkJet parts and assemblies.

**Chapter 7: Adjustments.** Explains how to properly adjust the HP ThinkJet printers.

**Chapter 8: Troubleshooting.** Contains information for testing and troubleshooting the HP ThinkJet printers.

**Chapter 9: Replaceable Parts.** Contains HP ThinkJet printer parts lists.

**Chapter 10: Reference.** Information to support the HP ThinkJet printer, including documentation summary and programming command set listings.

**Chapter 11: Product History.** Contains product history to adapt preceding HP ThinkJet printer information to this version service manual.

**Chapter 12: Diagrams.** Contains drawings and diagrams helpful in understanding the product's operation and troubleshooting.

---

## Chapter 1 Overview

Chapter 1 contains general product information. This information includes:

- **Manual Overview.** A brief look at the arrangement of information in the HP ThinkJet Printer Service Manual.
- **Accessories.** Lists HP ThinkJet accessories.
- **Product Specifications.** Lists the specifications related to the product features and performance.
- **Getting Acquainted.** This section introduces you to printer's keypad.
- **Battery Pack Information.** Provides information regarding the HP 2225B and 2225P battery packs, including the battery characteristics and signs of degradation.
- **Test Equipment and Tools.** Lists the tools and equipment recommended for HP ThinkJet Printer maintenance and repair.

## Accessories

Table 1-1. HP ThinkJet Printer Accessories

PART NUMBER	PART/ACCESSORY DESCRIPTION
92261A 51605R 51605B 51605G	<b>Ink-Jet Print Cartridges</b> Black Red Blue Green
51630A 92261N 51630J	<b>Ink-Jet Paper (finished sizes)</b> Z-fold, 500 sheets 8 1/2" x 11" Z-fold, 2500 sheets 8 1/2" x 11" Cut sheet, 500 sheets 8 1/2" x 11"
92261S	Acrylic ThinkJet Printer Stand
8120-1351 8120-1369 8120-1689 8120-1378 8120-2956 8120-2104	<b>Power Cords (HP 2225A and 2225D)</b> U.K. Australian European U.S. Denmark Switzerland
2110-0340 2110-0489 2110-0588 2110-0202	<b>Fuses (HP 2225A and 2225D)</b> US 400mA (120V setting) European 250mA (220V setting) U.K. 200mA (240V setting) Japan 500mA (100V setting)
82059D 82066B 82067B 82067B Opt 001 82068B 82069B	<b>Rechargers (HP 2225B and 2225P)</b> U.S. European 220V U.K. S. African Australian European 110V
82199S 82199A	<b>Battery Packs (HP 2225B and 2225P)</b> HP 2225B Battery Pack HP 2225P Battery Pack

Table 1-1. HP ThinkJet Printer Accessories (Cont.)

PART NUMBER	PART / ACCESSORY DESCRIPTION
82241AJ 82241A 82241AB 82241AU 82241AG 82241AA	<b>Power Modules (HP 2225C)</b> Japan U.S. & Canada Europe 220V U.K. Australia South Africa
10833D 10833A 10833B 10833C	<b>HP 2225A I/O Cables</b> 1/2 meter 1 meter 2 meter 4 meter
82167A 82167B 82167D	<b>HP 2225B I/O Cables</b> 1/2 meter 1 meter 5 meter
24542D 24542D 24542D	<b>HP 2225C and 2225P I/O Cables</b> HP Vectra & serial/par. interface card IBM PC/PC XT & parallel printer adaptor IBM AT & serial/parallel adaptor
13242G 17355M 92219N 92219M 17255D or 13242H 92219P 92219Z	<b>HP 2225D RS-232C Cables</b> HP Touchscreen Apple II, II+, or IIe & Super-Serial Card Apple IIc Apple Macintosh (software driver DN 35177M required) IBM with Asyn. Com. Adaptor IBM AT with Serial/Parallel Adaptor (IBM AT Serial Cable required) IBM PCjr
02225-90031 02225-90032 02225-90077 02225-90034 02225-90073 02225-90079	<b>HP 2225P Centronics Cable</b> IBM PC/PC XT & parallel printer adaptor  <b>Manuals</b> HP 2225A Owner's Manual HP 2225B Owner's Manual HP 2225C Owner's Manual HP 2225D Owner's Manual HP 2225P Owner's Manual HP ThinkJet Printer Service Manual

---

## Product Specifications

---

### Note



Physical, electrical, and environmental specifications can be found in Chapter 2, Site Planning and Requirements.

---

## Product Capabilities

<b>Print Speed</b> (characters/second)	150 cps (normal) 75 cps (expanded) 266 cps (compressed)
<b>Carriage Return Rate</b>	.53 seconds
<b>Linefeed Rate</b>	.08 seconds @ 6 lpi .06 seconds @ 8 lpi
<b>Paper Slew Rate</b>	5.28 seconds (11" paper), 2.08 ips
<b>Print Modes</b>	Normal, bold, and underline
<b>Character Spacing</b> (characters/inch)	6 cpi (expanded) 10.7 cpi (expanded-compressed) 12 cpi (normal) 21.3 cpi (compressed)
<b>Dot Spacing</b> (dots/inch)	96 x 96 dpi 96 x 192 dpi
<b>Dot Size</b>	.007" on HP Ink-Jet Paper
<b>Characters Per Line</b>	40 (expanded) 71 (expanded-compressed) 80 (normal) 142 (compressed)
<b>Paper Type</b>	Single sheet or Z-fold paper (HP ink jet paper recommended)
<b>Page Length</b> (switch selectable)	11" or A4



<b>Paper Width</b>	8.65" to 9.05"
<b>Printable Width</b>	6.7"
<b>Programming Command Set</b> (switch selectable)	HP PCL Level I Select IBM/Epson control sequences
<b>Character Sets</b> (switch selectable)	Roman8 USASCII Swedish IBM8 French German United Kingdom Spanish
<b>Typical Printer Usage</b>	Less than 40 pages per day
<b>Print Cartridge Life</b>	500 pages @ 1000 characters per page

## Interface

<b>Interface Types</b>	HP-IB (2225A) HP-IL (2225B) Centronics (2225C & 2225P) RS-232C (2225D)
<b>Buffer Size</b>	1K bytes
<b>2225A HP-IB Specs</b>	
Addressing	0 to 30
Listen Always & SRQ	Switch Selectable
<b>2225D RS-232C Specs</b>	
Baud Rate	1200, 2400, 9600, or 19200
Parity	Odd, Even, Zero, One, or None
Word Length	7 or 8 bits
Handshake Modes	DTR (Hardware) XON/XOFF

## Getting Acquainted

### HP ThinkJet Printer Part Identification

This section identifies HP ThinkJet printers and their parts. These parts are referred to throughout this manual.

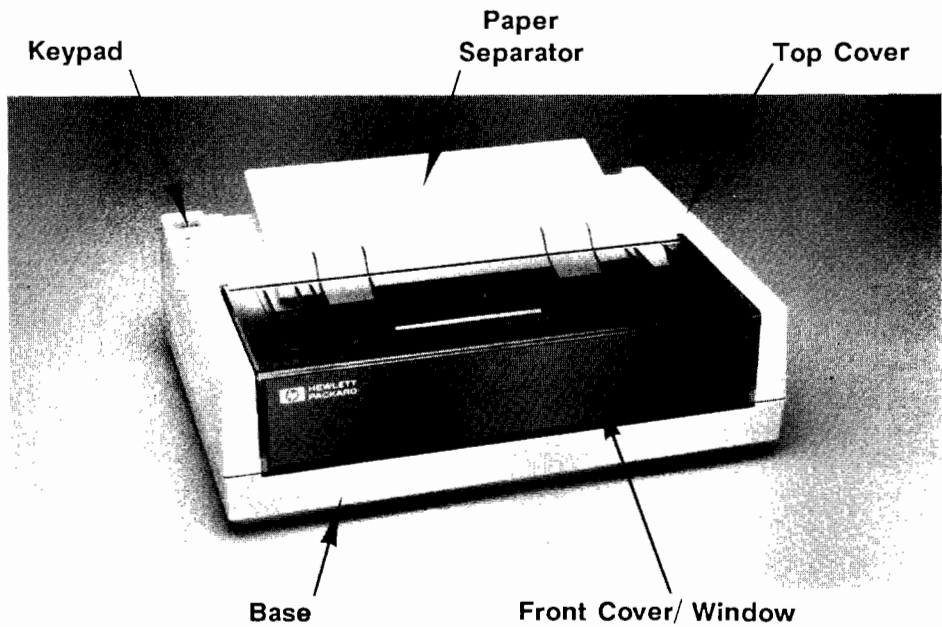

Figure 1-2. HP ThinkJet Printer Front View

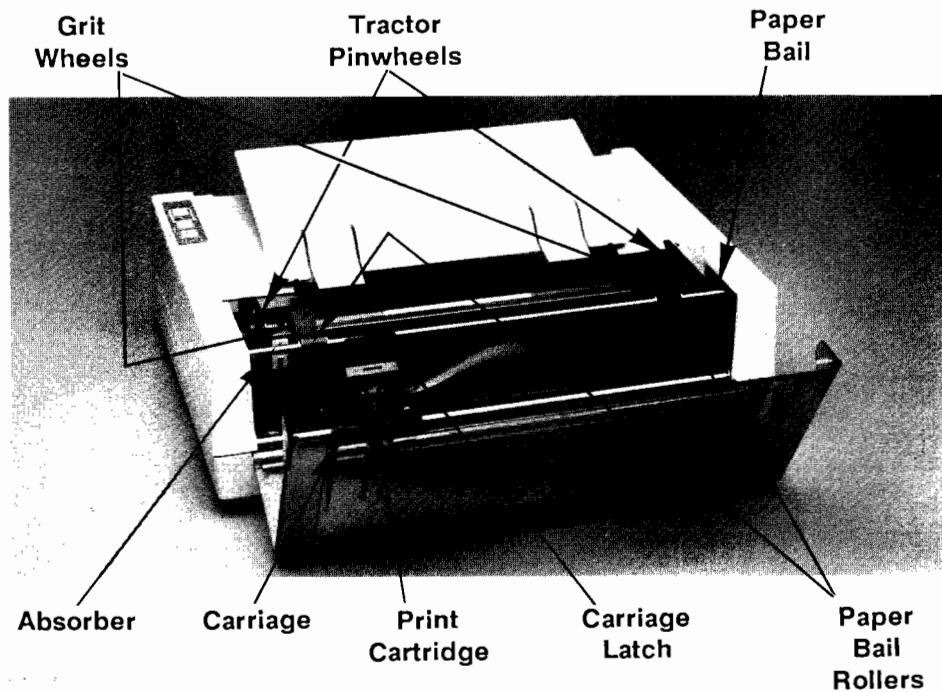

Figure 1-3. HP ThinkJet Printer Internal View

ThinkJet  
Identification By  
Backpanel

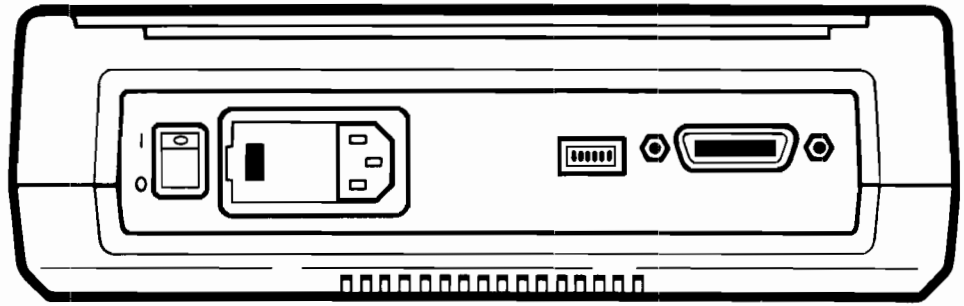

Figure 1-4. HP 2225A Rear View

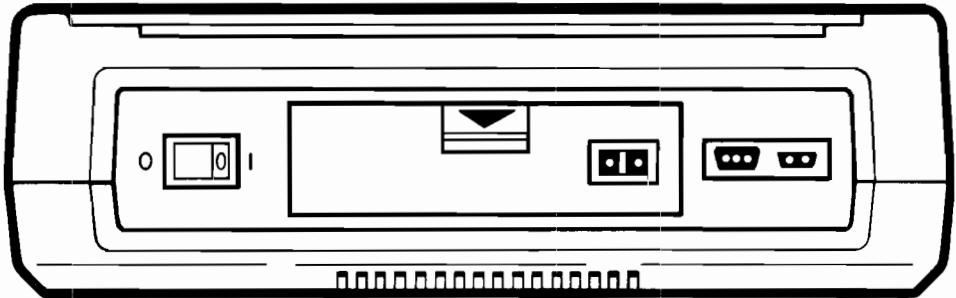

Figure 1-5. HP 2225B Rear View

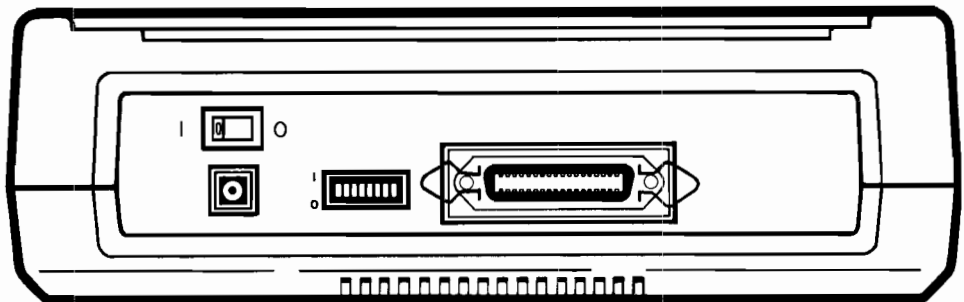

Figure 1-6. HP 2225C Rear View



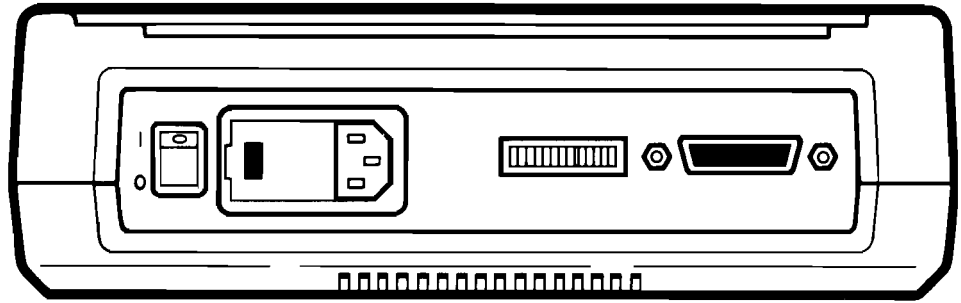

Figure 1-7. HP 2225D Rear View

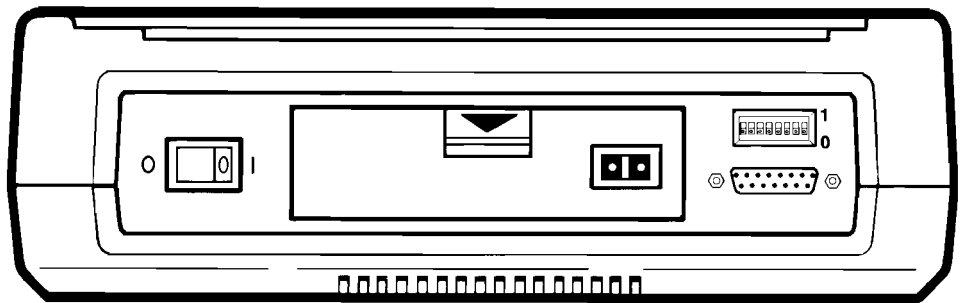

Figure 1-8. HP 2225P Rear View

**Note**



If your HP 2225C backpanel differs from Figure 1-6, you may have an earlier version HP 2225C printer. For more information on the earlier version HP 2225C Printers, see Chapter 11 "Earlier Version 2225C Printers".

## Keypad Lights and Keys

This section explains the functions of the HP ThinkJet keypad lights and keys.

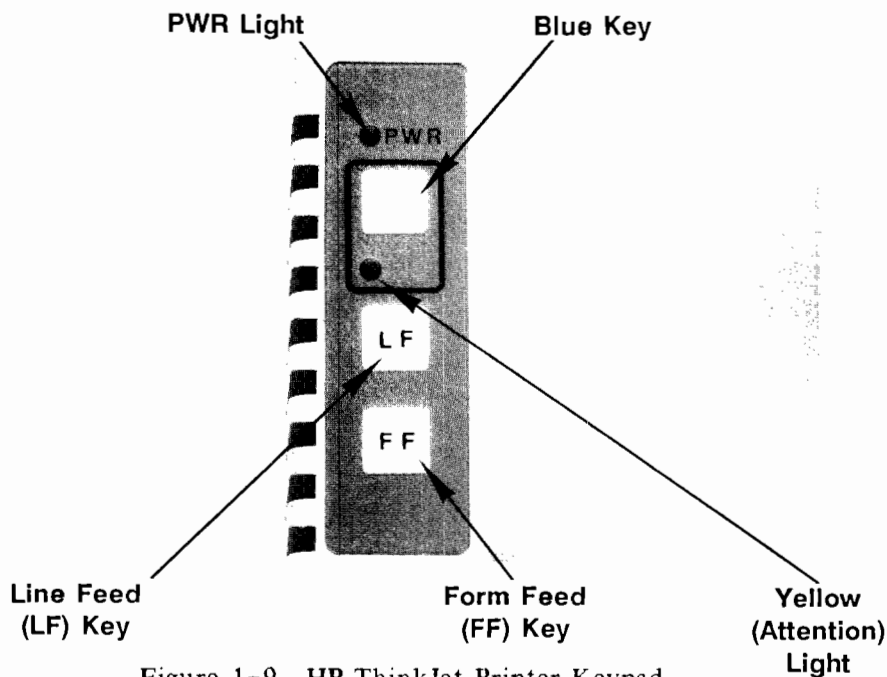

Figure 1-9. HP ThinkJet Printer Keypad

### PWR Light

The PWR light indicates when the printer is powered on.

On the HP 2225B and 2225P battery powered ThinkJet printers, the PWR light indicates the battery pack level condition. If the PWR light is flashing, the battery pack need recharging. If the HP 2225B or 2225P printer is powered on and the PWR light is off, the battery pack may be completely discharged.

### Yellow Light

The yellow "attention" light turns on in a steady condition when the printer runs out of paper. The yellow light begins flashing when paper is loaded and remains flashing until the blue key is pressed. The yellow light will also flash while paper is loaded if:

1. The printer is performing an internal self test (done immediately after the printer is turned on).
2. A self test error is detected.

### **Line Feed (LF) Key**

The LF key is used to advance the paper. Press the line feed key quickly to advance the paper a single dot row. Press the line feed key normally to advance the paper one line. If the line feed key is held down, the paper will advance one line, pause, then advance the paper until the key is released.

Pressing the LF key while turning the printer on will invoke the printer's printing self test.

### **Form Feed (FF) Key**

The FF key is used to advance the paper to the next top-of-form, providing the printer is set for the length of paper being used.

Pressing the FF key while turning the printer on will invoke the printer's printing self test.

### **Blue Key**

The blue key is used to reset the printer's top-of-form. If the printer runs out of paper, the yellow light will be on steady. Once paper is loaded, the yellow "attention" light will flash until the operator presses the blue key, setting the paper top-of-form position.

---

## Battery Pack Information

The battery pack information in this section applies to the HP 2225B and 2225P battery powered ThinkJet printers. Under normal operating conditions, a fully charged battery pack ThinkJet printer is capable of the following:

- Approximately two hours (or 200 pages) with the printer printing continuously without the recharger installed.
- Approximately 2.6 hours (or 275 pages) with the printer printing continuously with the recharger installed.
- Three days with power on and not printing (no recharger installed).

To maximize battery pack life, recharge the battery pack only when it is nearly discharged (PWR light flashing or off). Eight to eleven hours are required to recharge a battery pack fully. The battery pack may be recharged in or out of the printer.

If additional printing is attempted with a discharged pack and recharger, an approximate 20% printer duty cycle will result as the battery pack charges enough to allow printing and discharges again to low battery cutoff in the process of printing.

### Note



---

If an HP 2225B or 2225P ThinkJet printer is used with the recharger plugged in on a permanent basis and the battery pack is not occasionally fully discharged, then the battery pack may need replacement every 8 to 12 months due to NiCad memory effect which reduces the amount of charge the battery can hold.

---

## Battery Characteristics

Nickel Cadmium batteries exhibit behavior that is significantly different from other batteries. Instead of usual steady decrease in voltage with discharge, Ni-Cads have a nearly constant voltage through most of their charge life. The exceptions to this are the initial 5% of "overcharge" when the voltage is about .2 volts per cell higher and the final 3-5% of charge life when the voltage drops rapidly.

## Signs of Battery Degradation

Batteries that have been heavily used and/or constantly overcharged for long periods of time will display weakening symptoms that will eventually cause the battery to become unusable. Often these batteries will show an abnormally short charge life. A battery pack that has a charge life of 50 pages or less is probably showing signs of degradation. Another ailment is a consistent lowering of the battery voltage. A good battery will be fully charged at 8.5 volts, spend most of its charge life in the 7.2 to 7.6 volt range, and drop below that voltage when it is almost completely discharged. A battery that displays similar behavior, but at voltage levels consistently .5 or 1 volt lower, is showing signs of degradation.

---

### Caution

Do not incinerate or mutilate the battery pack. The battery pack may release toxic materials or burst under extreme heat. Do not connect together or otherwise short circuit the battery pack terminals. The battery pack may melt or cause serious burns. Use only HP battery packs with your printer. Use only HP rechargers with your battery pack.

---

### Note

For battery pack related troubleshooting, see Chapter 8, "Troubleshooting".

---

---

## Test Equipment and Tools

The following tools and equipment are recommended for proper HP ThinkJet printer maintenance and repair:

- TORX Kit, HP P/N 8710-1426
- Extended TORX T9 Bit, HP P/N 130-T9-MOU
- DVM, HP 3435A or equivalent
- Oscilloscope, HP 1741A or equivalent
- Logic probe, HP 545A or equivalent
- Long nose pliers
- Diagonal cutters
- Paper clip
- Tissue



## 2

# Site Planning and Requirements

---

### Introduction

This chapter contains important information, defining:

- Physical Specifications
- Electrical Specifications
- Environmental Specifications

This information will help to determine if the desired operating location satisfactorily meets HP ThinkJet printer requirements.

---

### Physical Specifications

<b>Product Dimensions</b>	290mm W x 90mm H x 210mm D (11.42" W x 3.54" H x 8.26"D)
<b>Packaged Dimensions</b>	420mm W x 165mm H x 350mm D (16.5" W x 6.5" H x 13.75")
<b>Product Weight</b>	
2225A	7.4 lbs (3.36 kg)
2225B	4.7 lbs (2.13 kg) without battery pack 5.5 lbs (2.5 kg) with battery pack
2225C	4.76 lbs (2.16 kg)
2225D	7.2 lbs (3.27 kg)
2225P	4.7 lbs (2.13 kg) without battery pack 5.5 lbs (2.5 kg) with battery pack

---

## Electrical Specifications

### 2225A & 2225D

Power Requirement	100, 120, 220, 240VAC (+5%/-10%) 50/60Hz
Voltage Setting	Switch Selectable
Printer Fuse	See Table 3-1

### 2225B

Power Requirement	Recharger country dependent See Table 1-1, HP ThinkJet Accessories
Battery Output Level	Above 6.5 volts-Normal Operation (PWR Light ON Steady) 6.2 to 6.5 volts-Operating (PWR Light Flashing) Less than 6.2 volts-Nonoperational (PWR Light OFF)

### 2225C

Power Requirement	Power Module country dependent See Table 1-1, HP ThinkJet Accessories
-------------------	--

### 2225P

Power Requirement	Recharger Country dependent See Table 1-1, HP ThinkJet Accessories
Battery Output Level	Above 6.8 volts-Normal Operation (PWR Light ON Steady) 6.7 to 6.8 volts-Operating (PWR Light Flashing) Less than 6.7 volts-Nonoperational (PWR Light OFF)

Power Consumption	17 watts (worst case)
-------------------	-----------------------

---

## Environmental Specifications

<b>Temperature</b>	
Operating	10 to 40 deg C (50 to 104 deg F)
Operating	10 to 55 deg C (50 to 131 deg F)
Survival	
Non-operating	-20 to 60 deg C (-4 to 140 deg F)
<b>Relative Humidity</b>	
Operating	10 to 90% RH @ 40 deg C
Non-operating	90% RH @ 60 deg C
<b>Altitude</b>	
Operating	0 to 4600 meters
Non Operating	0 to 15300 meters
<b>Electro-Static Discharge (ESD)</b>	
No catastrophic failure	<15kV
Probe Specifications	300 pF & 100 Ohms
<b>Acoustic Measurement Per ISO DP7779</b>	
Sound Pressure-LpA	<50 dBA @ 1 meter
<b>BTU Output</b>	58 BTU/hr

### Note



---

Recharge 2225B and 2225P battery packs between 50 and 104 degree F (10 to 40 deg C).

---



Notes

# Notes

# 3

## Installation and Configuration

---

### Introduction

This chapter contains the following information for installing and configuring the HP ThinkJet printer:

- Items Included
- ThinkJet Power Information
  - HP 2225A & 2225D Fuses and Voltage
  - HP 2225B & 2225P Fuses and Voltage
  - HP 2225C Fuses and Voltage
- Loading Paper and Installing the Print Cartridge
  - Loading Z-Fold Paper
  - Installing the Print Cartridge
  - Run the Self-Test
- ThinkJet DIP Switches
  - HP 2225A Address Select Switches
  - HP 2225C, 2225D, and 2225P Mode Select Switches
  - HP 2225D RS-232C Control DIP Switches

---

### Items Included

HP ThinkJet printers are shipped with the following items:

- ThinkJet Owner's Manual (part number printer dependent)
- Paper separator, HP P/N 02225-40032
- One print cartridge, HP P/N 92261A
- One pack of z-fold paper
- One power cord (2225A & 2225D only)
- Recharger (2225B & 2225P only)
  - (part number country dependent)
- Power Module (2225C only)
  - (part number country dependent)
- Battery pack (2225B & 2225P only)
  - HP 2225B Battery Pack P/N 02225-60005
  - HP 2225P Battery Pack P/N 02225-60091
- One HP-IL interface cable (2225B only, P/N 82167B)

---

## ThinkJet Power Information

The HP 2225A and 2225D ThinkJet printers are capable of operating from one of the following AC power sources:

- 100 volt AC, 50/60 Hz
- 120 volt AC, 50/60 Hz
- 220 volt AC, 50/60 Hz
- 240 volt AC, 50/60 Hz

The fuse box on the printer rear panel contains a voltage selector drum for selecting one of the four line voltages. Each printer is shipped with the voltage selector drum set to match local voltage requirements.

The HP 2225B and 2225P are battery powered ThinkJet printers. A recharger plugs into the printer battery pack for AC operation.

The HP 2225C ThinkJet printer has the transformer external to the printer in a power module. The correct power module is country dependent (See Table 1-1, Accessories). Unlike the HP 2225B and 2225P, the HP 2225C does not have a battery pack for portable operation.

## HP 2225A & 2225D Fuses and Voltage

### Setting the Voltage

To select the line voltage:

1. Remove the power cord from the printer.
2. Open the fuse box cover with a small bit screwdriver. The cover closes tightly but will yield to firm pressure.
3. Remove the voltage selector drum and rotate it to the setting that corresponds to the area's voltage requirements.
4. Install the drum in the fuse box so that the selected voltage setting is visible through the fuse box door when the door is closed.

---

### Note



**DO NOT** rotate the voltage selector drum while it is in the fuse box for it may damage the spring contacts in the fuse box.

---

## Installing/Replacing the Fuse

The HP 2225A and 2225D use a fuse that fits into a fuse carrier and slides into a slot in the fuse box. The fuse box contains slots for two carriers. The proper fuse and its carrier must be installed in the top slot. White arrows on the inside of the fuse box door point in the direction the fuse carrier is to be installed.

The correct fuse for the printer depends on the voltage requirement for your area. Each printer is shipped with the correct fuse installed for the location. Fuse rating requirements are printed on the product rating label on the back of the printer.

Table 3-1. HP ThinkJet Voltage and Fuse Table

Voltage Setting	Fuse Rating	Fuse Size	Fuse Carrier
100VAC	500mA TD	3 AG	White
120VAC	400mA TD	3 AG	White
220VAC	250mA TD	5 x 20mm	Black
240VAC	200mA TD	5 x 20mm	Black

To replace the fuse:

1. Remove the carrier from the slot and the fuse from the carrier.
2. Place the new fuse in the correct carrier and slide the carrier into the upper slot with the arrow on the end of the carrier facing out.
3. Close the fuse box door.

## HP 2225B & 2225P Fuses and Voltage

The HP 2225B and 2225P are battery powered ThinkJet printers. A recharger plugs into the battery pack for recharging and AC power operation. Different rechargers are available for different country's power and wall receptacle requirements. Therefore, an HP 2225B or 2225P can be operated worldwide by obtaining the correct recharger for the country. See Table 1- 1, HP ThinkJet Accessories, for recharger part numbers.

A nonreplaceable fuse is in each battery pack for short circuit protection. If the fuse blows, the battery pack must be replaced.

## HP 2225C Fuses and Voltage

The HP 2225C does not have an internal transformer or batteries. It uses an external AC adapter for the country's power and wall receptacle requirements. Therefore, one HP 2225C printer can be used in any country by obtaining that country's adapter.

There is no user replaceable fuse on the HP 2225C ThinkJet printer backpanel. The Main Logic PCA contains a fuse for current protection.

---

## Loading Paper and Installing the Print Cartridge

### Loading Z-Fold Paper

To load z-fold paper:

1. Open the front cover/window and paper bail.
2. Install the paper separator, as shown in Figure 3-1.

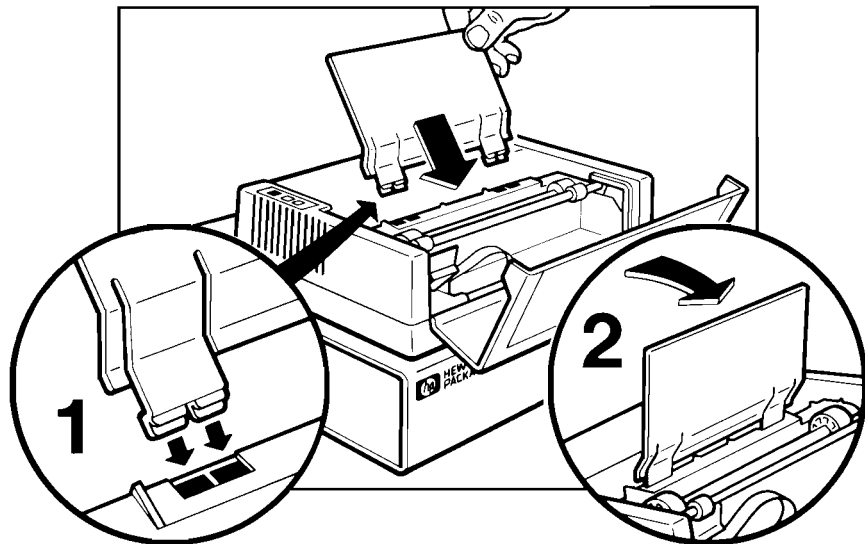

Figure 3-1. Installing Paper Separator

3. With the paper surface "print this side" down, slide the paper under the paper separator until the paper is visible between the paper bail and the tractor pinwheels. If the printer is on, the yellow attention light should now be flashing rather than on steady.



4. Place the z-fold paper holes on the tractor pinwheel pins and close the paper bail to hold the paper against the printer's grit wheels.
5. Press the LF key until the paper is positioned for the desired top-of-form position (the paper perforation should be just above the paper bail).
6. Close the window and press the blue button to set top-of-form.

## Installing the Print Cartridge

Warning 

---

**Ink contains 50% Diethylene Glycol. Harmful if swallowed. Keep out of reach of children.**

---

1. Open the window and lower the carriage latch.
2. Install the absorber in the absorber mount with the white side of the absorber toward you.

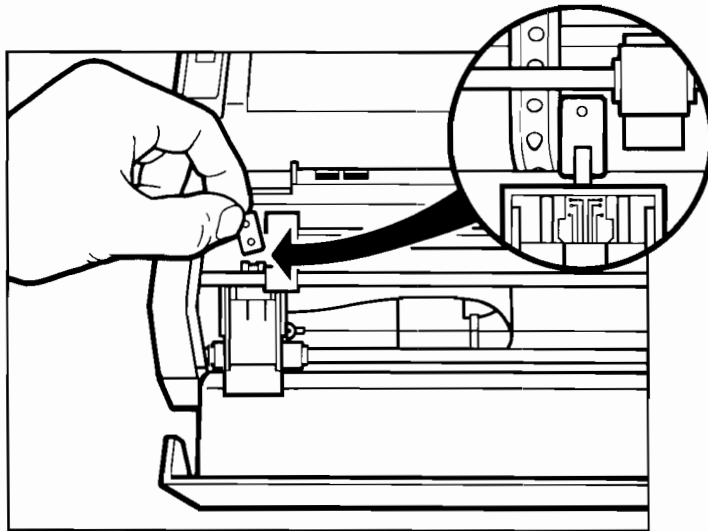

Figure 3-2. Installing the Absorber

3. Prime the print cartridge. See Chapter 4 on "Print Cartridge Maintenance" for priming and cleaning instructions.
4. Place the print cartridge in the carriage.
5. Raise the carriage latch, ensuring that it is in a fully locked position and close the window.

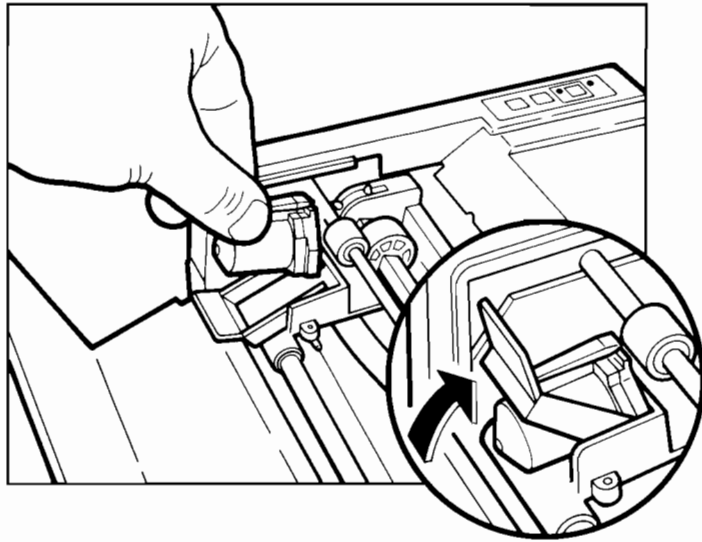

Figure 3-3. Installing the Print Cartridge

## Run the Self-Test

1. Press and hold the LF or FF key while turning the power switch on.
2. Release the LF or FF key.

The yellow light should blink twice (indicating the nonprinting self test passed) and print one page of the printing self test. For more information on the self test, see "Self Test" in Chapter 8 of this manual.

---

## ThinkJet DIP Switches

The HP ThinkJet printer backpanel switches are updated when the printer is powered on. Therefore, cycle the power switch off then on whenever the backpanel mode select switches are changed.

## HP 2225A Address Select Switches

The 2225A has seven HP-IB address select switches on the backpanel. The HP-IB address is a number from 0 to 30 which identifies each device connected to the interface. Using the HP-IB addresses, the controller can individually access the various devices on the interface bus. The HP 2225A printer is shipped from the factory with the address portion of the HP-IB configuration switch set to address 1.

Note



The Listen Always switch must be down for HP-IB addressing.

Table 3-2. HP-IB Address Selection

Switch A5	Switch A4	Switch A3	Switch A2	Switch A1	Address Selected
down	down	down	down	down	0
down	down	down	down	up	1
down	down	down	up	down	2
down	down	down	up	up	3
down	down	up	down	down	4
down	down	up	down	up	5
down	down	up	up	down	6
down	down	up	up	up	7
down	up	down	down	down	8
down	up	down	down	up	9
down	up	down	up	down	10
down	up	down	up	up	11
down	up	up	down	down	12
down	up	up	down	up	13
down	up	up	up	down	14
down	up	up	up	up	15
up	down	down	down	down	16
up	down	down	down	up	17
up	down	down	up	down	18
up	down	down	up	up	19
up	down	up	down	down	20
up	down	up	down	up	21
up	down	up	up	down	22
up	down	up	up	up	23
up	up	down	down	down	24
up	up	down	down	up	25
up	up	down	up	down	26
up	up	down	up	up	27
up	up	up	down	down	28
up	up	up	down	up	29
up	up	up	up	down	30
up	up	up	up	up	Test (Invalid Address)

**HP 2225C, 2225D,  
& 2225P Mode  
Select Switches**

The 2225C , 2225D, and 2225P ThinkJet printers contain 8 mode select switches to define the printer's default configuration and character set.

Table 3-3. Mode Select Switch Selections

Switch	Switch Function	Down Position	Up Position
1	Carriage Return Definition	CR=CR only	CR=CR and LF
2	Line Feed Definition	LF=LF only	LF=CR and LF
3	Perforation Skip	Disabled	Enabled
4	Page Length	11"	12"
5	Programming Command Set	HP PCL Level I	Select Epson Escape Sequences
6-8	Character Set Selection	See Table 3-4	See Table 3-4

Table 3-4. Character Set Selection

Character Set	Switch 6	Switch 7	Switch 8
Roman8	down	down	down
ANSI ASCII	up	down	down
Swedish	down	up	down
IBM8	up	up	down
French	down	down	up
German	up	down	up
U.K.	down	up	up
Spanish	up	up	up

**HP 2225D  
RS-232C Control  
DIP Switches**

The 2225D has a set of five DIP switches (labeled RS-232C) which control the RS-232C interface; baud rate, parity, and handshake mode. The printer is shipped from the factory with all five switches in the down position.

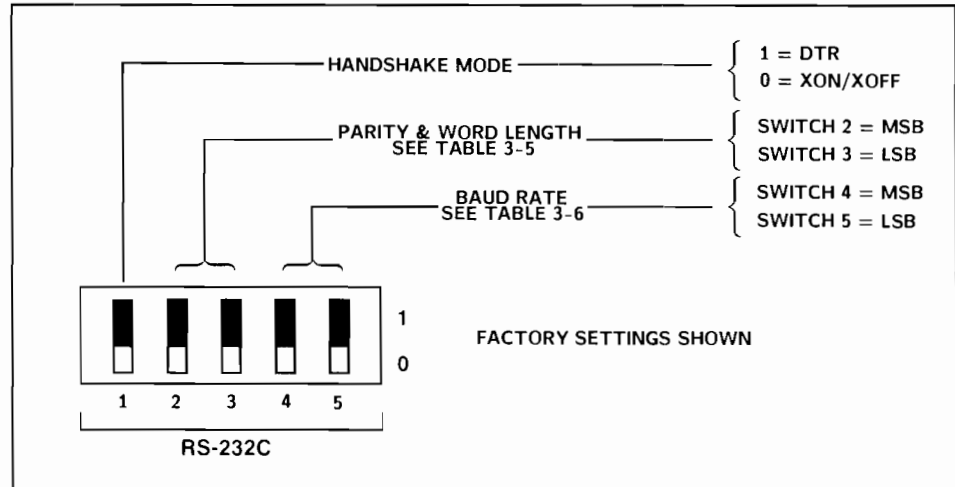

Figure 3-4. RS-232C DIP Switch Definition

Table 3-5. RS-232C Parity/Word Length

Switch 2	Switch 3	Parity	Word Length
down	down	None	8 Bits
down	down	Zero	7 Bits
down	up	Odd	7 Bits
up	down	Even	7 Bits
up	up	One	7 Bits

Table 3-6. RS-232C Baud Rate

Switch 4	Switch 5	Baud Rate
down	down	9600
down	up	19.2K
up	down	2400
up	up	1200

---

## Notes

# 4

## Maintenance

---

### Introduction

This chapter contains information to aid in maintaining the HP ThinkJet printer. Information is arranged in the following order:

- Maintenance Philosophy
- Print Cartridge Maintenance
- Cleaning

---

### Maintenance Philosophy

The HP ThinkJet printer does not require periodic maintenance. However, it is a good practice to visually check and clean the printer routinely, as explained in this chapter.

The print cartridge should be primed and wiped prior to installation. If a printout is missing a row or rows of dots, replace or clean the print cartridge as explained in the section labeled "Print Cartridge Maintenance".

**Warning**



---

**Ink contains 50% Diethylene Glycol. Harmful if swallowed. Keep out of reach of children.**

---

## Print Cartridge Maintenance

Maintaining the HP ThinkJet disposable print cartridge is easy and convenient. If dots are missing on a printout, remove the print cartridge from the printer. Likely, one of five print cartridge problems occurred:

1. Carriage latch not closed tightly to push the print cartridge against the carriage contacts.
2. Dirty contacts on the print cartridge or printer's carriage.
3. Dust is clogging the print cartridge orifice plate (chrome square area).
4. The print cartridge requires priming.
5. The print cartridge ran out (or is running out) of ink.

If the bladder is collapsed, similar to Figure 4-1, the print cartridge is out of ink and needs replacement. For the replacement print cartridge number, see Table 1-1 on HP ThinkJet Accessories or the Hewlett-Packard Computer Users Catalog.

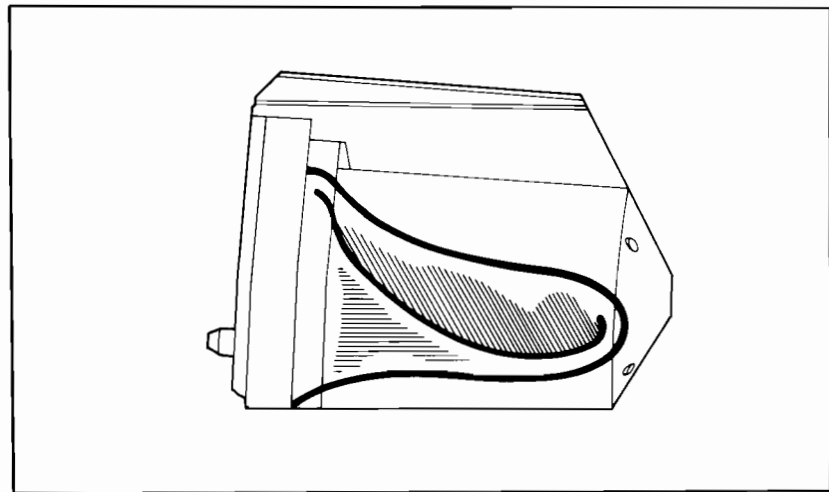

Figure 4-1. Print Cartridge Out-of-Ink Condition

If the print cartridge contains ink and the printout is missing one or two dot rows, wipe the print cartridge orifice plate with a clean dry tissue to remove any dust clogging the nozzle. Wipe the contacts on the print cartridge and the printer carriage with a swab or clean soft tissue.



If the printout eventually loses several rows of dots and the cartridge is not out of ink, the cartridge probably needs priming. Prime and clean the print cartridge as follows:

1. Hold the print cartridge in your hand with the flat surface up.
2. Form a paper clip as shown in Figure 4-2.
3. Insert the modified paper clip in the center hole and press upward until a puddle of ink covers the square chrome orifice plate.

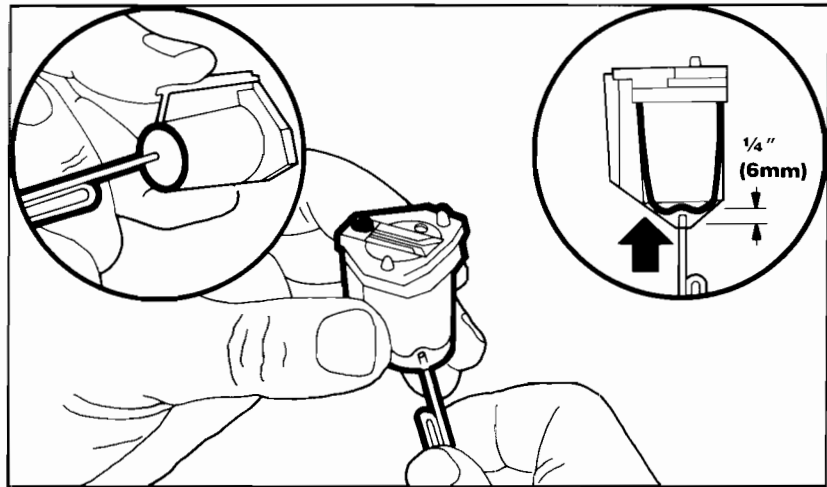

Figure 4-2. Priming the Print Cartridge

4. Wipe the print cartridge flat surface with a clean tissue.
5. Wipe the two columns of contacts on the print cartridge with a clean soft tissue. Clean the carriage contact points on the printer with a swab.
6. Install the print cartridge and verify proper printing operation.

### Multiple Print Cartridge Failures

Another possible cause for single or multiple dots missing during printing is the print head voltage ( $V_{head}$  or VHD) from the Main Logic PCA. If the print cartridge is replaced but the same dot row is missing, print head voltage may be out of spec and damaging the print cartridges. See "Power Supply" in Chapter 8, Adjustments, for checking  $V_{head}$  or VHD on the Main Logic PCA.



---

## Cleaning

The printer's interior and exterior should be examined for smudges, dust, etc. Clean the exterior with a soft cloth moistened with mild detergent and water. Examine the interior areas with the window open. Accumulations of paper or lint should be carefully removed by brushing the loose material onto a cloth, or by using a vacuum cleaner.

The carriage rail can be cleaned with a dry clean cloth. **Do not lubricate the carriage rail.** The oil would mix with the paper lint, forming a paste, hindering and slowing the printer's carriage movement.

Ink or paper dust on the window can be removed with a clean soft cloth or tissue. **Do not use any solvent.**

---

## Notes

# 5

## Functional Description

---

### Introduction

This chapter contains information to aid in understanding the HP ThinkJet printer general operation. See Chapter 12 for block diagrams and schematics. Information is arranged as follows:

- Microprocessor (CPU)
- Power Supply
  - HP 2225A & 2225D
  - HP 2225B & 2225P
  - HP 2225C
- Print Head Drive Logic
- Stepper Motor Drive
  - HP 2225A & 2225D
  - HP 2225B & 2225P
  - HP 2225C
- Keypad
- Home Switch Assembly
- Backpanel
- Reset
  - HP 2225A & 2225D
  - HP 2225B & 2225P
  - HP 2225C
- HP 2225A HP-IB I/O
- HP 2225B HP-IL I/O
- HP 2225C & 2225P Centronics I/O
- HP 2225D RS-232C I/O
- Mechanism
  - Paper Advance
  - Carriage Drive
  - Paper Path
  - Heat Dissipation

---

### Microprocessor

HP ThinkJet printers are controlled by a custom IC designed and manufactured by Hewlett-Packard. Other ICs in the family include RAM and ROM. The RAM is used as a graphics or text buffer and the ROM contains the character patterns. In addition, many custom hardware features are incorporated into the microprocessor to ease the burden of controlling the printer and communicating with the outside world.

---

## Power Supply

The power supply's main purpose is to provide a high tolerance voltage level for the print head and logic circuit currents. To reduce costs the power supply components occupy the same logic Printed Circuit Assembly (PCA) as the logic components.

### HP 2225A & 2225D

AC power comes through the line module which is drum selectable to 100, 120, 220, or 240 volts. The transformer is specially designed for these four primary voltages, plus safety and RFI requirements. There are two sets of secondary windings which are transient filtered by capacitors C6 and C7, full wave rectified by diodes CR1 through CR8 (CR1-CR4, CR7, and CR16 on the 2225D), and filtered by capacitors C1 and C2. C16 is a high frequency filter capacitor.

Regulator VR1 supplies the high tolerance voltage to the print head. The print head supply voltage must be 22.68 volts, plus or minus 0.8%. It is adjusted to fall into this range by removing combinations of resistors R14, R15, and R16 which are connected in parallel for precision. The boards are loaded with all resistors in place for a target range of 22.52 to 22.86 volts. If the voltage falls outside this range, various combinations of resistors are clipped out. If the voltage is less than 20.51 volts or greater than 22.86 volts, one of the components in the regulator circuit is bad. Resistors R1 and R2 provide the divider network for the regulator's unique output voltage. Two output voltages come from this circuit: VHD provides the high accuracy head voltage; unregulated voltage VMP, at about 30 volts, powers the paper motor, while the regulated VMC supply of 24 volts powers the carriage motor.

Regulator VR3 is the logic level +5 volt supply, plus or minus 5%. It is capable of delivering up to 100 mA. Two output voltages are also provided from this circuit: VDD which comes directly from the regulator for the logic, and VDRAW is the unregulated 10 volt filtered output from the transformer. Because VDRAW is unregulated, when the unit power on VDRAW swings from 0 to 10 volts; VDD waits until VDRAW reaches something greater than 6 volts before it comes up. This is useful for power-on indication.

Capacitors C37 and C10 are current reservoirs for the regulators. Capacitor C37 is required to be a low "equivalent series resistance" (ESR) part. Capacitor C8 filters high frequencies. Diodes CR9 and CR10 provide protection to the regulators in case the voltage at the output terminal exceeds that at the input terminal, usually at power-off. Zener diode VR6 traps transients that may also harm the regulator.

## HP 2225B & 2225P

### Battery Pack

The HP 2225B & 2225P printers are totally powered by a battery pack, which contains six sub-C Ni-Cad cells of 1.2 amp-hour capacity, and the electronics necessary to recharge them. Four diodes in the pack form a bridge rectifier for the incoming low voltage AC from the wall charging transformer. A resistor controls the charging current to the battery. A **nonreplaceable fuse** in the battery pack protects against high currents should the pack be inadvertently shorted.

### Boost Converter

Because the HP 2225B & 2225P printers are totally battery operated, its nominal voltage is far less than that required for the print head. A boost circuit is needed to convert the 6 to 9 volts available to the 22 volts. The boost converter operates on the "switching" power supply principle. A monostable multivibrator, 555 timer IC, is biased by resistors and a capacitor to produce a stable square wave. The output is current limited and drives a transistor to conduct current from the battery rail VBAT through an inductor to ground. As the inductor charges, its magnetic field energizes. As the inductor discharges, its magnetic field collapses and acts as a current source for short periods of time. The transistor is off so the current passes through a diode and charges a reservoir capacitor. The reservoir capacitor voltage is divided by a resistor network to complete a feedback loop. The resistor divider combination is used to adjust the voltage output to a plus or minus 1% tolerance. At assembly, all four resistors in the divider are loaded. Then, the output voltage is measured and compared against a table. By clipping out resistor combinations in the divider circuitry, the appropriate voltage tolerance can be obtained.

The voltage at the resistor divider node is compared to a voltage reference, VREF. The voltage reference is a very high-precision, temperature compensated zener diode. When the resistor network voltage is too high, a comparator output goes low and inhibits output from the 555 timer. When the resistor network voltage is low, a comparator enables the oscillator output.

## HP 2225C

The power module is a direct plug-in transformer that provides AC input to the printer. Four input options are available for use with nominal line voltages of 100, 120, 220, and 240 VAC. The transformer supplies 9 volts +/- 0.4 volts at 1.5 amperes, at nominal line voltage and frequency.

AC power is rectified by a full-wave bridge rectifier circuit to yield a single DC input voltage (called Vraw) which is typically 10 volts. Vraw is the source of all power to the product. The analog circuitry will operate correctly if Vraw remains in the range of 7.5 to 16 volts.

Digital ICs are supplied by a linear regulator (VR3) from Vraw providing VCC (5 volts +/-5%). The output of the motor power supply (VMP) is in the range of 26 to 28.4 volts with the capability of providing 480 mA of continuous current and peak outputs of 800 mA for up to 1 second (the output voltage is not guaranteed to remain within regulation during this time).

The print cartridge requires an accurate power supply that can deliver high peak current. The output of 22.73 +/- 0.21 volts is obtained by trimming resistors R10, R11, and/or R12 in a voltage divider network. The supply will provide instantaneous output of 800 mA for as long as 30 usec. Average output current, however is 50 mA or less. This is accomplished by having a low-dropout, low power linear regulator circuit using the motor power supply as its input. A large output capacitor (C7) provides the peak current capability.

---

## Print Head Drive Logic

The thermal ink jet print head requires precise on-time control of the thermal resistors as well as the correct firing sequence required for formation of characters. The custom microprocessor contains a dedicated controller specifically for print head control and off-loading the CPU for data processing. The processor puts the dot information into print head driver buffers. The print head voltage (Vhead or VHD) is supplied to all of the dots simultaneously, but a particular dot is enabled only when its drive transistor is on. Zener diodes provide voltage protection from transients and electrostatic discharge (ESD).

---

## Stepper Motor Drive

### HP 2225A & 2225D

The paper advance motor has ample resolution for its purpose, so it requires a simple drive scheme. Three drive transistors in pack U10 and one in pack U9 are enabled in the proper half-stepping sequence via the processor bus. The unregulated voltage VMP is tied to the commons of both phase pairs. When one (or two) of the Darlington's are enabled, current from the common passes through the motor phase to ground. Protection diodes incorporated in the Darlington packs filter high voltage transients which are generated when the magnetic field around the enabled phase collapses, through VR20, VR21, and R30 to ground.

Because the carriage stepper motor demands accuracy and velocity, a regulated voltage is required. Regulator VR13 supplies 24.0 volts, plus or minus 5% from unregulated voltage VMP. The regulated voltage is labeled VMC. Zener diode VR15 protects the input of the regulator from transient spikes generated from the paper advance motor. Resistor R10 provides a load for the regulator when no phase is turned on (during paper advance or printer idle) to prevent oscillation. Capacitor C38 is a current reservoir for the regulator. Capacitor C9 is a high frequency filter. Zener diode VR14 provides overvoltage protection for the regulator. Diode CR13 protects the regulator should the voltage on the output exceed the voltage on the input, usually during power-down.

Diodes CR14 and CR15 isolate the phases so that the collapse of the magnetic field from one phase pair does not effect the other. C19 and C20 are filters, smoothing the resonating points at the speeds required during normal operation. All four Darlington drive transistors are in pack U10.

#### HP 2225B & 2225P

Because the HP 2225B & 2225P printers are battery operated, it must use low voltage stepper motors which are very sensitive to the saturation losses present in the drive transistors, and high peak current requirements. For these reasons discrete bipolar transistors are used. The motor phase information from the processor turns on stepper motor drive buffers, which in turn sink enough current from the base of the drive transistors for full saturation and minimum voltage drop.

The drives are designed around the can-stack stepper motors. The low cost and high reliability of this type of motor justified their selection. Both the carriage and paper advance motor drives have identical supply requirements and are supplied directly by the batteries. The paper drive draws roughly twice the current of the carriage drive. For this reason the bias resistor network for the bipolar driver transistors is slightly different in value as compared to the carriage motor drive.

The paper drive is designed more for its torque than for speed to accommodate the variable paper drag. The motor is simply stepped in the proper sequence for the desired number of print rows and turned off. The motor is full-stepped with two coils energized at once to achieve maximum mechanical power output. The step rate is 200 full-steps per second.

#### HP 2225C

The paper and carriage motor drive circuitry use IC U10 and one drive transistor in U9 to provide proper half-stepping sequence via the processor bus. VMP (for the paper motor) and VMC (for the carriage motor) are tied to the commons of both phase pairs. When U10 outputs are enabled, current from the common passes through the motor phase to ground.

---

## Keypad

There are three keys and two indicator LEDs on the keypad. Because only two lines from the microprocessor are dedicated to the three keys, diodes are needed to decode which key is being pushed (if any). The PWR LED is controlled by battery voltage sensing latches in the power supply for indication of battery condition (on, steady, or flashing). The yellow "attention" LED connects directly to the out-of-paper sensor and an output line on the microprocessor. When there is an out of paper condition, VDD will pass through the LED to ground, as it will should the output line of the microprocessor go low.

For keypad operation information, see Chapter 1 on "Getting Acquainted".

---

## Home Switch Assembly

The "home switch" is an infrared opto sensor mounted below the carriage path. As the carriage transverses the platen, a blade on the carriage passes between an LED source and a phototransistor, interrupting the light and turning off the transistor. An LED has a predetermined life expectancy in hours of emission, so the source is only enabled when the print head is moving. The phototransistor portion of the interrupter, when turned on, pulls the voltage at the collector to ground through a pull-up resistor. The phototransistor collector triggers a comparator to inform the CPU of the carriage position. The comparator output is low when the phototransistor is on (no interruption) and high when the phototransistor is off (carriage is passing through the sensor).

The microprocessor monitors the home switch for the presence of the carriage blade at selected times. The algorithm employed not only verifies the operation of the home switch, but also determines whether the carriage motor is stalled or has lost synchronization. In any event, a failure of the open loop control scheme is detected and further printer operations are suspended.

---

## Backpanel

The rear panels of the 2225A and 2225D contain the power switch, fuse box, configuration switches, and the interface connector. The fuse box contains a receptacle for a power cord, and behind an access door, the AC fuse and line voltage selector.

The 2225A mode/address switch has seven rocker switches which control the mode of operation; Listen Always, Service Request Enable (SRQen), I/O diagnostic, and HP-IB address. The 2225A I/O connector is IEEE-488 compatible.



The 2225C and 2225P mode switch has eight rocker positions for CR definition, LF definition, perforation skip, page length, control sequence mode, and character set selection.

The 2225D has two sets of switches. A set of eight rocker switches (MODE switches) perform the same function as the 2225C MODE switches. The second set of switches (RS-232C switches) are used for RS-232 interface control; baud rate, parity/word length, and handshake mode.

The 2225A and 2225D will operate on 100, 120, 220, or 240 volts AC, 50/60 Hz.

---

## Reset

### HP 2225A & 2225D

A reset condition can be received from either the I/O or from the power-on sensor. The power-on sensor consists of comparator U7A, with zener diode VR7 connected to the inverting input. Resistor R11 acts as a voltage divider for VDRAW (the unregulated logic voltage) and the zener. The inverting input of the comparator is connected to the node of the voltage divider consisting of resistors R5 and R6; dividing VDD (the regulated logic voltage). Because the unregulated VDRAW voltage rises before the regulated VDD, and the voltage at the node of the zener is lower than the voltage at the node of the resistor divider, the output of the comparator remains low until VDD reaches the threshold voltage (4.5 volts) needed by the logic circuits. Resistor R7 and capacitor C15 smooth the comparator's output during transients, as required by the microprocessor. Resistor R12 is for pull-up.

### HP 2225B & 2225P

Because logic components have unknown operation until the voltage reaches a certain threshold, a RESET must be provided to halt the microprocessor during power-on. When the power is turned on, the reset line is not allowed to go high (allowing the processor to operate) until VDD exceeds 4.5 volts.

### HP 2225C

A reset condition can be received from either the I/O (INIT) or from the power-on sensor. The power-on sensor consists of comparator U7A with VREF connected to the inverting input. R15 and R16 act as a voltage divider. VDD must reach the threshold voltage before the reset condition is released.

---

## **HP 2225A HP-IB I/O**

The 2225A and 2225B use the same system microprocessor, which means it uses the same HP-IL microcode I/O driver, even though the 2225A is HP-IB and the 2225B is HP-IL. The 2225A converts its HP-IB input to HP-IL; this is accomplished in the I/O board. The I/O board itself is basically the same product as the 82169A HP-IL/HP-IB Interface pod used with low cost Hewlett-Packard HP-IL products.

HP-IB has eight data lines, eight control lines, and six grounds. HP-IL has two transmit lines and two receive lines which go directly into the system microprocessor for interpretation. When the HP-IB printer is connected to the system bus, data on the bus is presented to the HP-IB transceiver IC U6 where it is buffered for the microcomputer U4, (an 8048 with on-board ROM and RAM). The microcomputer handles data communications between the HP-IB IC and the HP-IL IC U1, which converts the parallel data from the I/O microcomputer into serial data needed by the 2225B microprocessor HP-IL circuits.

The HP-IB address switches, located on the rear panel, are buffered by IC pack U3. The output of the pack is enabled through quad latch U2 from the microcomputer, and is used to hold the control line signals for the HP-IB chip. The rest of the discrete components perform other logic requirements.

For more HP-IB Interface information, see Appendix D in the HP 2225A ThinkJet Printer Owner's Manual.

---

## **HP 2225B HP-IL I/O**

The majority of the HP-IL interface is contained within the custom microprocessor integrated circuit. The HP-IL interface does require a few added components not designed into the IC. These components are needed primarily for impedance matching and ESD protection. The HP-IL transformer T1 isolates the receiver and transmitter circuitry from the HP-IL interconnect wiring.

Zener diodes VR 1 through VR 4 clamp voltage spikes at a peak of 33 volts. Resistors R31 and R32 along with capacitors C11 and C12, control the rise time, filter out high frequencies, and provide impedance matching (100 ohm) to the microprocessor inputs.

## HP 2225C & 2225P Centronics I/O

The HP 2225C & 2225P have standard eight-bit parallel (Centronics) interfaces for connection to both HP and non-HP devices. Implementation of the parallel interface is achieved by the following lines (\* indicates the line is active low):

- Eight data lines
- Three input handshake lines:
  - \*Strobe (\*STR)
  - \*Acknowledge (\*ACK)
  - Busy
- Three status lines:
  - Select (SLCT)
  - Paper Empty (PE)
  - \*ERROR
- One reset line:
  - \*Initialize (\*INIT)

The HP 2225P requires a special cable for I/O pinout compatibility.

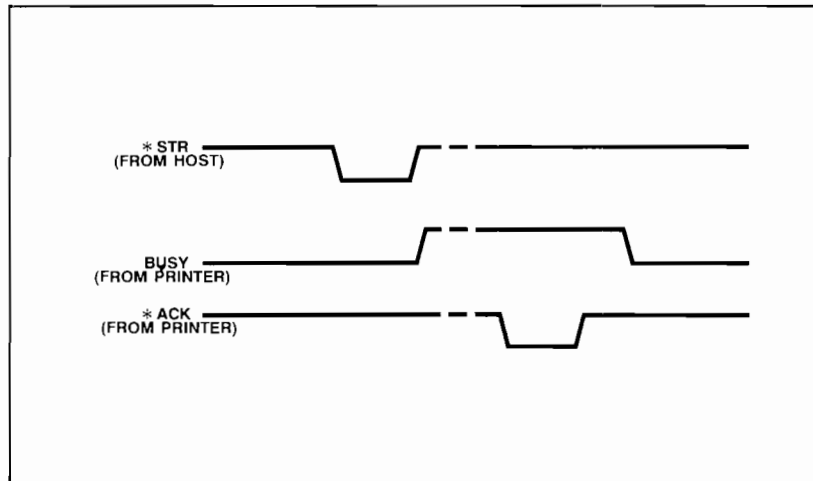

Figure 5-1. Parallel (Centronics) Handshake

The strobe line (\*STR) is set low when the computer is ready to send data. The microprocessor clocks data into an external latch on the \*STR falling edge and sets busy high to indicate the printer cannot accept more data until the current byte is processed. When the printer is ready to receive more data, it pulses the acknowledge line (\*ACK) low which in turn sets busy low.

If a paper-out or carriage position lost error occurs (i.e. PE high or

\***ERROR** low, respectively), the printer will accept data until the buffer is full. **PE** is tied to ground on the 2225P printer.

On the 2225P, the busy line is set true (high) after each line of data received if battery pack power drops below 6.49 volts. The printer will not accept another line of data until the line of data in the buffer is printed, thus conserving battery power. The 2225P requires a special I/O cable for IBM Centronics pinout compatibility.

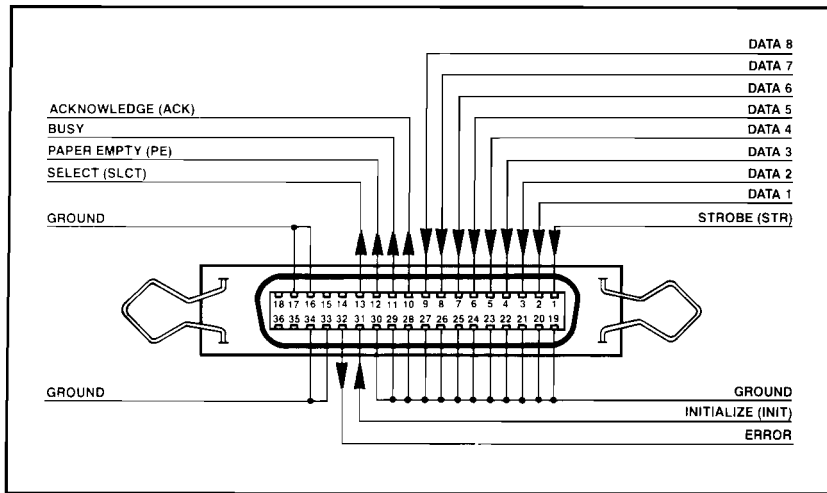

Figure 5-2. HP 2225C I/O Pinout

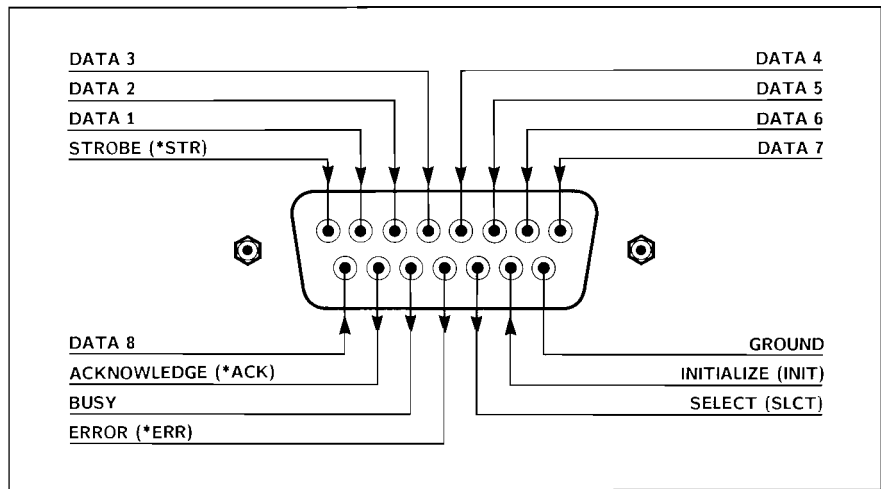

Figure 5-3. HP 2225P Backpanel Connector Pinout

## HP 2225D RS-232C I/O

The 2225D serial interface is fully compatible with EIA RS 232-C standards. The printer supports two methods of handshaking to prevent a printer buffer overflow condition, resulting in a loss of data:

- DTR (Data Terminal Ready or Hardware Handshake)
- XON/XOFF (DC1/DC3)

The handshaking mode is selectable by setting a dip switch:

- Mode switch 2 up selects DTR
- Mode switch 2 down selects XON/XOFF

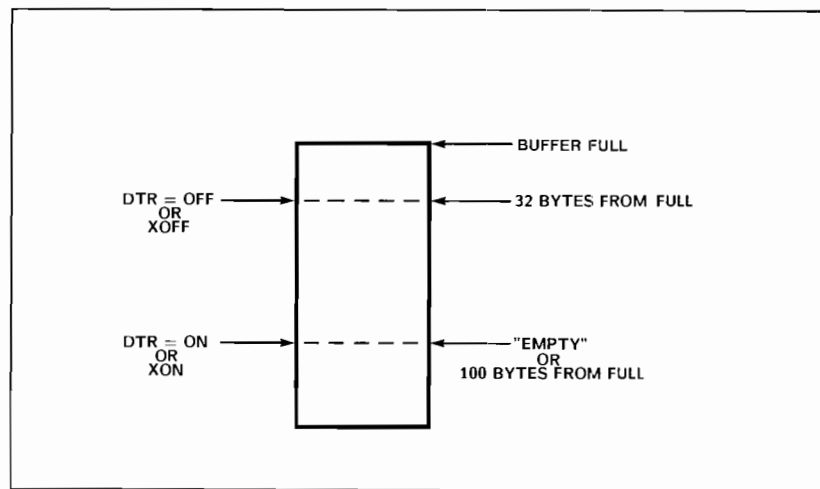

Figure 5-4. Serial Interface Handshaking

### DTR (Data Terminal Ready)

DTR, also known as hardware handshake mode, controls the transmission of data from the host to the printer by the logic level of DTR, pin 20. When the buffer is 32 bytes from being "full", the printer sets DTR "OFF" (-12 volts) requesting data transmission to stop. The printer continues printing, reducing the I/O buffer level until the buffer has room for 100 bytes of data (empty). The printer then sets DTR to "ON" (+12 volts) requesting data transmission to resume.

## XON/XOFF

XON/XOFF is similar to the DTR (Hardware Handshake) mode except the printer sends a command to the host indicating I/O buffer status rather than setting a hardware logic level. When the buffer is 32 bytes from "full", the printer sends the ASCII code DC3 (XOFF) to request the computer to stop sending data. The printer requests data transmission to resume when the buffer is "empty" by sending the ASCII code DC1 (XON).

## Serial Pin-out Information

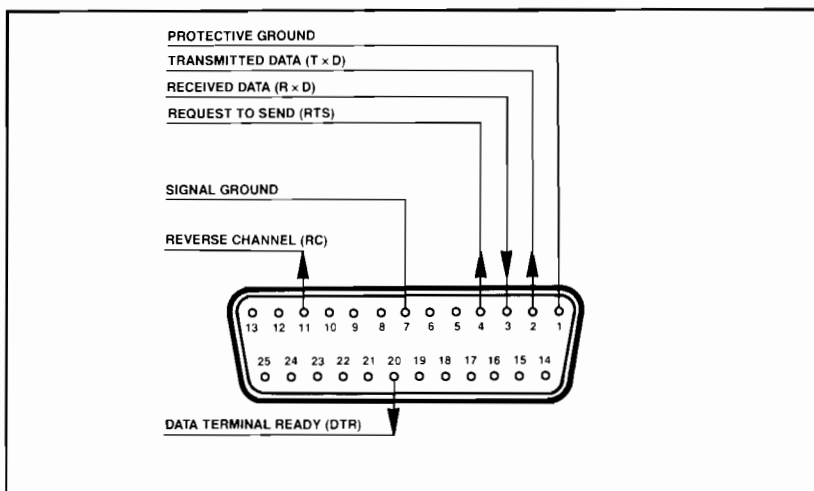

Figure 5-5. RS 232-C I/O Pin Connector

**Pin 1, Protective Ground.** This conductor serves as an electrically grounded line for connecting the cable shield.

**Pin 2, Transmitted Data.** Bit serial data transmitted to the computer from the printer. This line is used with XON/XOFF handshaking.

**Pin 3, Received Data.** Bit serial data transmitted to the printer from the computer.

**Pin 4, Request to Send.** An output from the printer that is always "ON" (+12V) when the printer is powered on.

**Pin 7, Signal Ground.** The established reference potential for all data communication.

**Pin 11, Reverse Channel.** This pin is directly tied to pin 20, Data Terminal Ready.

**Pin 20, Data Terminal Ready.** Signal line for hardware handshake mode. Data Terminal Ready is "ON" (+12 volts) when the printer is powered on and is able to receive data. DTR is set "OFF" (-12 volts) to stop transmission of data from the host.

---

## Print Mechanism

The print mechanism dimensions are 11 inches wide by 6.25 inches deep by 3 inches high, and can accommodate 80 character columns of print at 12 characters per inch, for a total printing width of 6.7 inches. Total weight is 1.8 pounds. The mainframe is an injection molded plastic which accommodates the mounting scheme for the drive systems and sensing devices.

## Paper Advance

Paper is advanced using a stepper motor with a 7.5 degree step angle at full step (48 steps per revolution). Rotational motion is translated through a 6:1 gear reduction train to the drive scheme which consists of both a grit wheel for single sheet feeding and a pin wheel for traditional z-fold paper. Each full-step of the motor advances the paper one vertical dot row (0.010 inches). Twelve steps are required to advance the paper one line at 8 lines per inch. The right tractor pinwheel is adjustable to accommodate variations of paper width from 8.65 to 9.05 inches.

Out-of-paper is detected by a magnetic reed switch. A lever with a magnet is positioned the paper path above the switch. As the paper is inserted, the magnet is pushed away, opening the switch. When paper runs out, dropping the lever, the magnet again closes the switch indicating out-of-paper. This occurs approximately 0.7 inches before the end of paper reaches the print region.

Paper slew rate is approximately 2 inches per second. There is no manual paper advance or backup capability.

## Carriage Drive

The head carriage rides on a single guide rail in the back, and is guided in the front by a track molded into the mainframe. At the far left, the track is curved to tilt the head carriage away from the paper, allowing ease of paper loading. This position is the "home" position. Tilting the carriage also prevents the paper from contacting the print head while idle.

A stepper motor with a 9 degree half-step angle (400 half steps per revolution), translates rotational motion through a 5:1 gear reduction and a drum/cable assembly for linear motion. This corresponds to one dot column of printing (0.010 inches). The velocity of the carriage is extremely constant, enough to allow for interpolation of position between the motor half-steps, for a total possible horizontal accuracy of 0.005 inches. Horizontal resolution is 640 dot columns on motor half-steps and 1280 dot-columns on motor quarter-steps.

The maximum speed of the motor is 1200 half-steps per second (150 characters per second). High speeds are achieved by "ramping" the motor steps. A "ramp" consists of 32 half-steps of the motor, each with an increasing step rate for acceleration. The step rate is increased from 200 half-steps per second to 1200 half-steps per second during this time. A similar "ramp" is needed to reduce the motor speed.

An optical switch is mounted in the mainframe in the carriage path to sense the carriage's passing. The switch serves dual purposes, both of which occur at power-on or reset. First, because the system operates "open-loop" (there is no feedback of carriage position), there must be some initial indication of carriage location. At power-on the carriage sweeps approximately two inches to the right, then sweeps left until it encounters the switch, indicating location. The carriage position is thereafter sensed and checked periodically.

The carriage moves several times thru the sensor for measuring carriage backlash. The microprocessor then compensates carriage backlash during bidirectional printing.

## Paper Path

Entry and exit of paper is from the top. A guide, molded into the case, ensures that single sheets are loaded correctly. The static-resistant platen frame mounts the grit and pinwheel drive, and acts to separate the entering and exiting paper.

## Heat Dissipation

The carriage stepper motor dissipates 2.9 watts and the paper advance stepper motor 6.6 watts. Heat due to the print head is considered negligible. Since both motors are not operating simultaneously, the average power is 3.7 watts in text mode (based on a 22% duty cycle for the paper motor and 78% duty cycle for the carriage motor). Most heat (6.6 watts) will be dissipated when the printer is performing form feeds. The mechanism is specified to operate in a maximum 40 degree celsius environment.



# 6

## Removal and Replacement

---

### Introduction

This chapter explains how to remove and replace the following HP ThinkJet printer parts and assemblies:

- Top cover (Removal 6.A)
- Mechanism (Removal 6.B)
- 2225A PCAs (Removal 6.C)
- 2225B PCA (Removal 6.D)
- 2225C PCA (Removal 6.E)
- 2225D PCAs (Removal 6.F)
- 2225P PCAs (Removal 6.G)
- Mechanism Assembly Removal Procedures
  - Grit Wheel & Tractor Pinwheel (Removal 6.H)
  - Carriage Assembly (Removal 6.I)
  - Bail Assembly (Removal 6.J)
  - Pinch Roller (Removal 6.K)
  - Home & Out of Paper Switches (Removal 6.L)

Each removal procedure is given a unique removal procedure number to aid in locating the desired procedure in the chapter. Reverse the procedure for part and assembly replacement. Be sure to read all notes for removal/replacement ease and reducing the risk of damage to the printer.

---

## Top Cover (6.A)

1. Turn the printer off and remove the power cord or battery pack from your printer.
2. Remove four TORX screws holding the top cover to the printer. These screws are recessed in the bottom of the printer's base.
3. Open the window and carefully lift the top cover up, far enough to disconnect the keypad cable from the Main Logic PCA.
4. Disconnect the keypad cable from the Main Logic PCA.

---

### Note



When replacing the cover, ensure the front edge of the window rests on the front edge of the base before the top cover is lowered into place.

---

---

## Mechanism (6.B)

1. Turn the printer off and remove the power cord or battery pack from your printer.
2. Remove the top cover (Removal 6.A).
3. Remove the three TORX mechanism mounting screws. Two screws are located in the mechanism carriage path area. The third screw is on the bottom of the printer's base.
4. Disconnect the ground wire or wires (if applicable) from the paper motor shield at the right side of the mechanism.
5. Carefully lift the mechanism to obtain access to the cables from the mechanism to the Main Logic PCA.
6. Disconnect the stepper motor, home switch, paper out switch, and print head cables.
7. Remove the mechanism from the printer.

---

## 2225A PCAs (6.C)

1. Turn the printer off and remove the printer power cord.
2. Remove the top cover (Removal 6.A).
3. Remove the mechanism assembly (Removal 6.B).
4. Remove the two hex standoff screws from the backpanel.
5. Remove the four nuts securing the HP-IB I/O PCA to the mounting studs.
6. Disconnect the I/O PCA flex cable and lift the backpanel from the printer base.
7. Detach the ground cable between the ground plane and I/O PCA. Remove the HP-IB I/O PCA.
8. Remove the four I/O PCA standoffs and standoff studs.
9. Remove all screws holding the transformer and Main Logic PCA to the ground plane and base.
10. Disconnect the ground wire between the transformer and the Main Logic PCA. Disconnect the transformer cable from the Main Logic PCA and remove the Main Logic PCA.

---

## 2225B PCA (6.D)

1. Turn the printer off and remove the battery pack from the printer.
2. Remove the top cover (Removal 6.A).
3. Remove the mechanism assembly (Removal 6.B)
4. Disconnect the power switch connector and I/O connector from the PCA.
5. Remove the backpanel by removing the two TORX backpanel mounting screws, located in the battery pack cavity. Access to the screw heads is through two holes on the top of the battery pack cavity top.
6. Remove the TORX screws holding the PCA to the metal ground plane and printer base. Remove the PCA from the printer.

---

## 2225C PCA (6.E)

1. Turn the printer off and disconnect the AC adapter.
2. Remove the top cover (Removal 6.A).
3. Remove the TORX Logic PCA mounting screws.
4. Remove the Logic PCA & backpanel from the ground plane.

---

## 2225D PCAs (6.F)

1. Turn the printer off and remove the power cord.
2. Remove the top cover (Removal 6.A)
3. Remove the mechanism assembly (Removal 6.B)
4. Disconnect the I/O PCA flex cable between the Main PCA and the I/O PCA.
5. Remove the two I/O connector standoff screws from the backpanel.
6. Lift the backpanel out of the printer base and disconnect the I/O PCA and fuse box ground wires from the printer ground plane and Main Logic PCA.
7. Remove the I/O PCA mounting screws and remove the I/O PCA from the backpanel.
8. Disconnect the transformer connector from the Main PCA.
9. Remove the transformer mounting screws from the Main PCA and ground plane and remove the transformer from the Main PCA.
10. Remove all remaining Main PCA mounting screws and remove the Main PCA from the ground plane and printer base.

---

## 2225P PCAs (6.G)

1. Turn the printer off and remove the printer's battery pack.
2. Remove the top cover (Removal 6.A).
3. Remove the Mechanism Assembly (Removal 6.B).
4. Remove the parallel interface connector standoffs from the backpanel.
5. Disconnect the I/O PCA grounding wire from I/O PCA.
6. Remove the TORX I/O PCA mounting screw.
7. Disconnect the I/O flat cable from its I/O PCA connector by pulling up on the connector cap. The I/O cable should then easily slide out of the I/O PCA connector.
8. Remove the I/O PCA from the printer.
9. Disconnect the power switch connector from the Main Logic PCA.
10. Remove the Main Logic PCA mounting screws. Remove the Main Logic PCA.

## Mechanism Assembly Removal Procedures

The following procedures explain how to remove ThinkJet printer mechanism assemblies. Each procedure assumes the printer is powered off and the top cover removed.

### Grit Wheel & Tractor Pinwheels (6.H)

1. Remove E-rings from both ends of the platen shaft (shaft holding grit wheels).
2. Remove the output gear and dowel from the right side of the shaft. Be careful not to lose the dowel when the gear is removed.
3. Remove both sleeve bearings then lift the shaft free from the mechanism. Remove the desired wheels from the shaft.

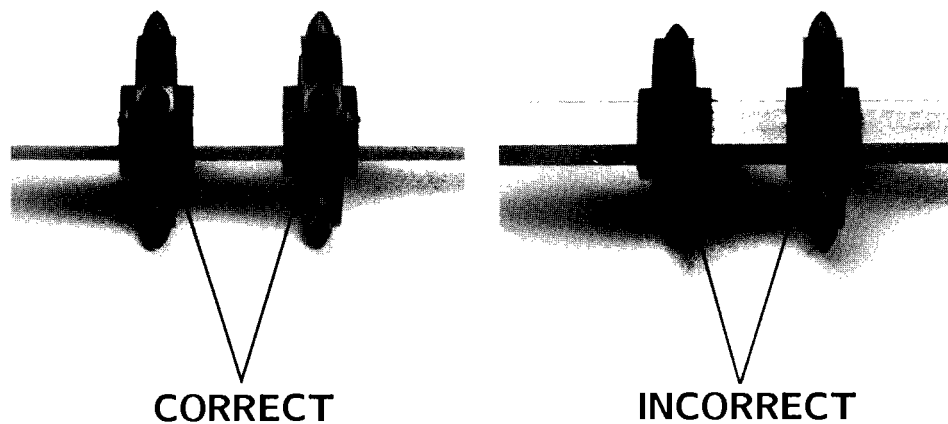

Figure 6-1. Tractor Pinwheel Replacement

#### Note



When reinstalling the platen shaft, place both grit wheels on the shaft and temporarily set the shaft in the mechanism with the dowel hole positioned on the right side. Position the wheels so they fit between the flanges on the platen frame. When installing the tractor pinwheels, ensure the pins are positioned the same on the shaft.

## Carriage Assembly (6.1)

1. Remove the mechanism (Removal 6.B).
2. Remove the print cartridge.
3. Move the carriage to the full left position and remove the T7 screw that secures the cable to the carriage. The screw can be accessed through the bottom cutout in the mechanism frame.

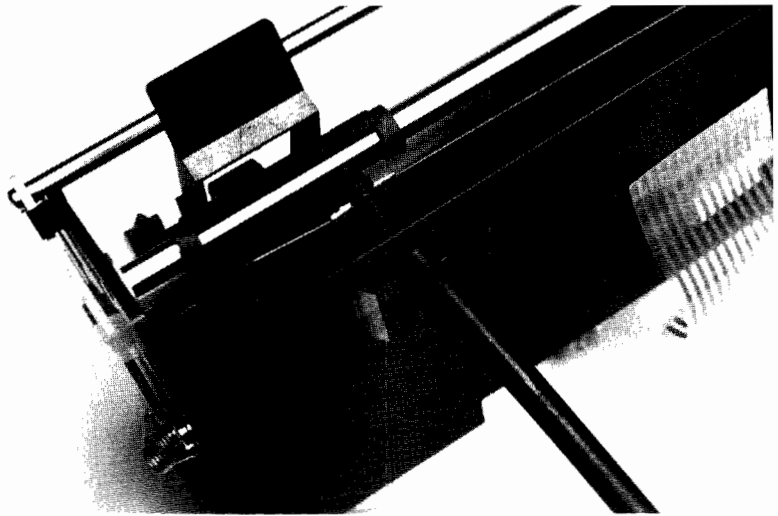

Figure 6-2. Removing the Carriage Screw.

4. Remove the two E-rings from the inside of the carriage shaft. Remove the shaft and carriage assembly.

## Bail Assembly (6.J)

If you wish to just remove a pinch roller from the bail assembly, see Pinch Roller Removal (Removal 6.K).

1. Lift both bail arm springs to the outward position, pinch legs together, and remove the bail arm springs.

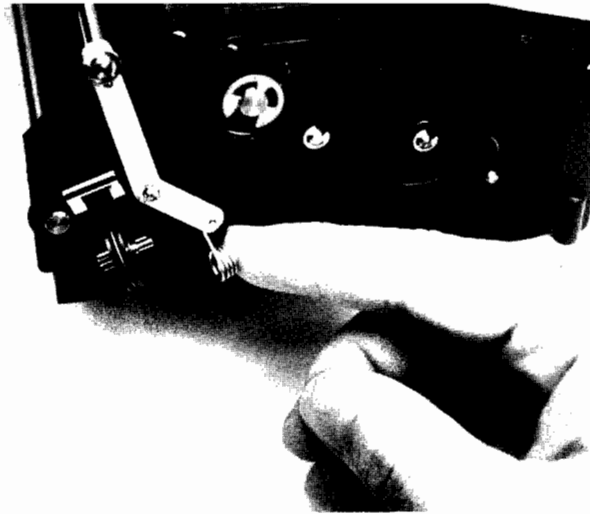

Figure 6-3. Bail Arm Spring Removal

2. Remove the two bail arm E-rings holding the bail arms to the mechanism.
3. Remove the bail arms.

### Note



---

When reassembling the bail assembly, it is important to note that the springs are different for each side. See Figure 6-4.

---



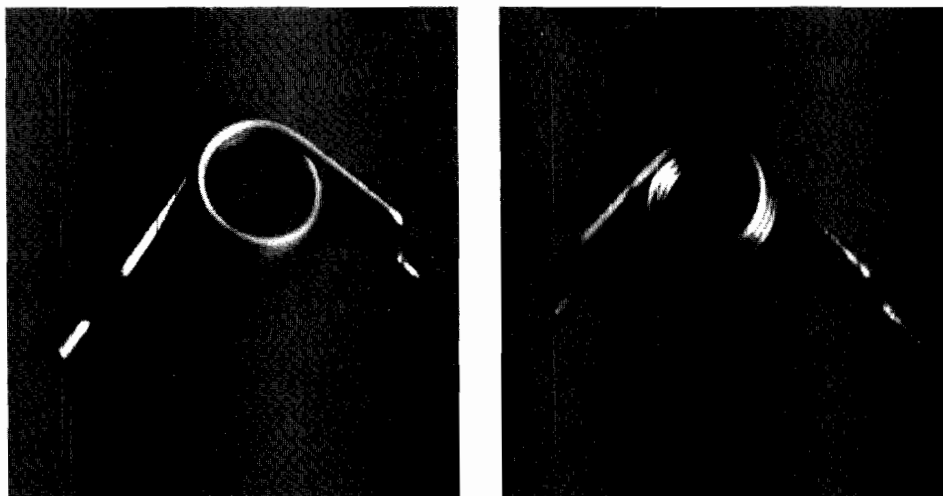

Figure 6-4. Bail Arm Springs.

**Note**



To install the bail springs, place the short end of the spring in the bail arm hole and the longer end in the printer frame hole. If the two legs are properly seated, the spring can be pushed down easily to its normal position. If it does not position easily, the spring legs are not correctly set.

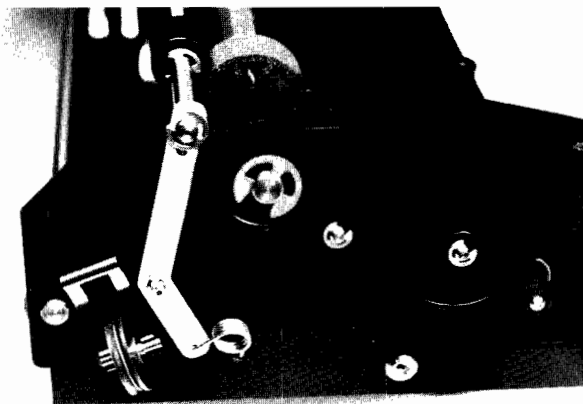

Figure 6-5. Correct Spring Position



## Pinch Roller (6.K)

1. Remove the right or left bail shaft E-ring (whichever is closest to the pinch roller to remove).
2. Pull the loose bail shaft end out of the bail arm.

**Note**



---

Be careful not to loose the dowel between the bail arm and the bail shaft.

---

3. Remove the pinch roller E-ring to allow the roller to slide off the bail shaft.

**Note**



---

When reinstalling the bail arm to the bail shaft, remember to install the dowel in the hole on the bail shaft and position the dowel in the bail arm slot.

---

## Home & Out of Paper Switches (6.L)

1. Remove the mechanism assembly (Removal 6.B).
- 2A. To remove the home switch, remove the home switch mounting screw.
- 2B. To remove the out of paper switch, loosen the two out-of-paper switch mounting screws. Remove the reed switch from the loose mounting screws.

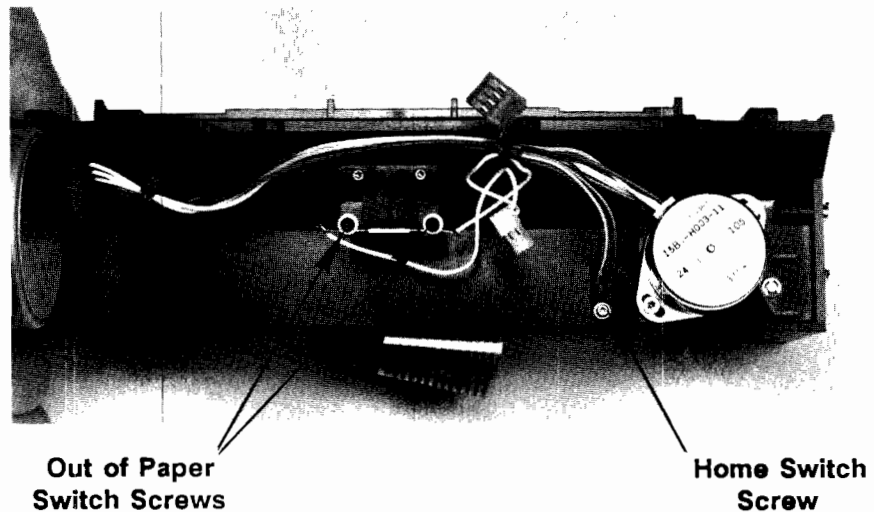

Figure 6-6. Removing the Home & Out of Paper Switches

3. Cut the tie wrap holding the switch to the other cables. Remove the switch from the mechanism.

### Note



---

When reinstalling the home or out of paper switch, remember to tie wrap the switch cable to the other cables.

---

---

2025-2026

## Notes

# 7

## Adjustments

### Introduction

This chapter explains how to adjust the HP ThinkJet printer power supply print head voltage (VHD or Vhead) and identify a mechanism that is bail arm adjustable. When replacing the Main Logic PCA, print head voltage is factory set and should not require adjustment.

### Bail Arm Adjustment

The bail arm adjustment is performed on early version ThinkJet printer mechanisms only. If you do not have an early version mechanism, no bail arm adjustment is necessary. To determine if you have an early version mechanism, remove the top cover (See Chapter 6 for removal procedure) and look at the left side of your bail arm assembly. If the bail is connected to the left bail arm with a screw, the bail arm adjustment applies. Disregard the bail arm adjustment procedure if your ThinkJet printer bail is attached to the left bail arm with a retaining ring. See Figure 7-1.

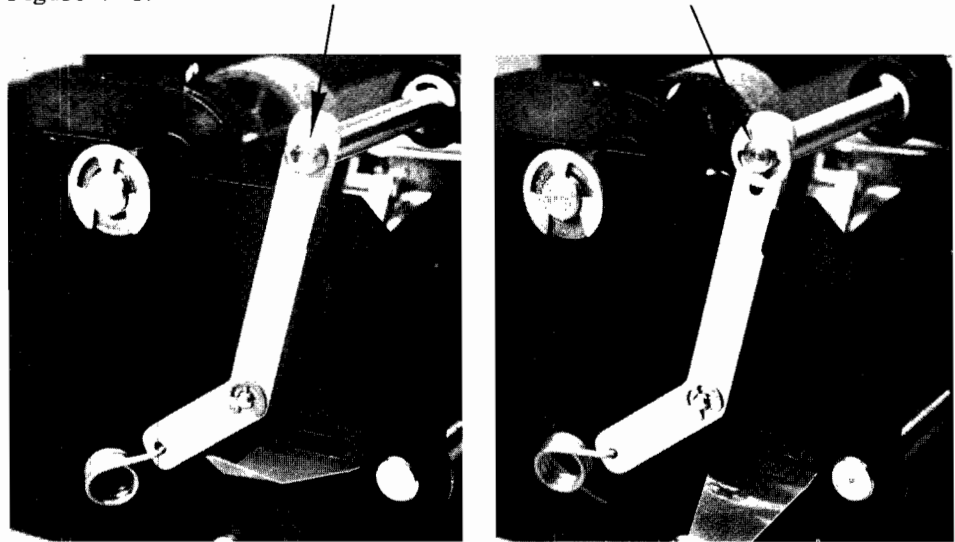

Figure 7-1. Bail Assembly Identification

To adjust the bail arm, see "Bail Arm Adjustment" in Chapter 11, Product History.

## Power Supply

The HP ThinkJet printer power supply contains an adjustable voltage, the print head voltage (VHD or Vhead, depending on the HP ThinkJet printer). The print head voltage is set by measuring VHD or Vhead with all resistors installed, looking up the measured voltage on a lookup table, and removing the appropriate resistors to get the print head voltage within the designated specification.

### Note



If necessary, see Chapter 6 for removing the top cover and Chapter 12 for locating Vhead or VHD on the Main Logic PCA.

## HP 2225A & 2225D

The power supply for the print head is specified as 22.682 volts, +/- 0.18 volts at J2(6). It is adjusted into this range by removing combinations of resistors R14, R15, and R16 (see Table 7-1). A new board is loaded with all resistors in place. In this condition, the voltage should be between 20.51 and 22.86 volts. If it is out of this range, one of the 6 components that determine this voltage is bad. Clipping the resistors will increase the voltage to bring it into range and is always done at the factory for replacement PCAs.

Table 7-1. 2225A & 2225D Print Head Voltage Table

Measured Voltage	Action
<20.51 volts	Defective Part
20.51 to 20.65 volts	Remove R14, R15, R16
20.66 to 20.95 volts	Remove R14,R15
20.96 to 21.27 volts	Remove R14,R16
21.28 to 21.58 volts	Remove R14
21.59 to 21.89 volts	Remove R15,R16
21.90 to 22.21 volts	Remove R15
22.22 to 22.51 volts	Remove R16
22.52 to 22.86 volts	IN SPEC-No Change Required
>22.86 volts	Defective Part

**HP 2225B, 2225C,  
& 2225P**

The print head supply (Vhead) for the HP 2225B, 2225C, and 2225P printers is specified as 22.73 volts, +/- 0.21 volts. Vhead is adjusted to fall into this range (22.52 to 22.94 volts) by removing combinations of resistors in a voltage divider circuit. Clipping resistor combinations should decrease Vhead and bring it into the 22.52 to 22.94 volt range. If Vhead is out of the 22.52 to 25.63 volt range, one of the loopback components that determine this voltage is faulty. Tables 7-2 and 7-3 assume Vhead is measured with all resistors installed.

Table 7-2. HP 2225B & 2225P Print Head Voltage Table

Measured Voltage	Action
25.63 volts	Defective Part
25.63 to 25.18 volts	Remove R55, R56, R57
25.17 to 24.75 volts	Remove R55,R56
24.74 to 24.33 volts	Remove R55,R57
24.32 to 24.00 volts	Remove R55
23.99 to 23.67 volts	Remove R56,R57
23.66 to 23.30 volts	Remove R56
23.29 to 22.94 volts	Remove R57
22.93 to 22.52 volts	IN SPEC-No Change Required
<22.52 volts	Defective Part

Table 7-3. 2225C Print Head Voltage Table

Measured Voltage	Action
25.63 volts	Defective Part
25.63 to 25.18 volts	Remove R10, R11, R12
25.17 to 24.75 volts	Remove R10,R11
24.74 to 24.33 volts	Remove R10,R12
24.32 to 24.00 volts	Remove R10
23.99 to 23.67 volts	Remove R11,R12
23.66 to 23.30 volts	Remove R11
23.29 to 22.94 volts	Remove R12
22.93 to 22.52 volts	IN SPEC-No Change Required
<22.52 volts	Defective Part

---

## Notes



# 8

# Troubleshooting

---

## Introduction

This chapter contains the following information:

- Self Tests
  - Nonprinting Self Test
  - Printing Self Test
- Overall Troubleshooting
- Troubleshooting the Main Logic PCA
  - Troubleshooting the Kernel
  - Troubleshooting the Carriage Motor Circuitry
  - Troubleshooting the Home Switch Circuitry
  - Troubleshooting the Print Head Circuitry
- Battery Pack Troubleshooting
- Troubleshooting Hints

---

## Self Tests

The HP ThinkJet printer has two internal self tests:

- Nonprinting Self Test
- Printing Self Test

## Nonprinting Self Test

The nonprinting self test checks:

- CPU
- Timers
- Internal and external RAM
- Internal and external ROM

The nonprinting self test occurs at power-on or as the first part of the printing self test. If the printer passes the nonprinting self test, the yellow light on the keypad will blink twice (if paper is loaded).

If the printer fails the nonprinting self test, the ThinkJet processor (CPU) pins that control dot firing are used to report the part of the test that failed. Power to the print head is turned off at this point; dots are not actually fired. See "Troubleshooting the Kernel" in the "Main Logic PCA Troubleshooting" section. See "Troubleshooting the Kernel" in the "Main Logic PCA Troubleshooting" section.

## Printing Self Test

The printing self test can be invoked by two methods:

1. Send an Esc z to the printer.
2. Press the LF or FF key while turning the printer on. Release the LF or FF key.

The printer executes the nonprinting self test. If the printer passes the nonprinting self test, it prints a self test pattern (See Figure 8-1).

The printing portion of the test is stopped if one of the following happens:

1. The test fails because the carriage position is not known.
2. A device clear command is received, in which case printing stops immediately and a device clear is executed.
3. The power is turned off.

The self test is suspended if:

1. The printer runs out of paper.
2. The battery voltage is too low to run the printer (2225B or 2225P).

The self test will resume after either of these two conditions are fixed.



---

## Overall Troubleshooting

Use the following **general procedure** to troubleshoot the **HP ThinkJet printer**. This procedure ensures that the **basic printer functions** are working properly. **If the printer has more subtle problems**, refer to **Table 8-4, Troubleshooting Hints**.

1. With paper installed, does the printer power up correctly? At power-on, the printer should do the following:
  - The red **PWR** light should be on.
  - The yellow "attention" light should blink twice and go out (if paper installed).
  - The print head should sweep through the home switch twice and then return to its left-most position.

If the unit powers up correctly, it indicates correct operation of the CPU, RAM, ROM, carriage motor, home switch, and most of the power supply. Go to step 2.

If the printer does not power up correctly:

- A. If the red **PWR** light does not come on and motors do not move, check the line fuse, fuse box, transformer circuitry, and power supply. In the 2225B and 2225P (**PWR** light off or flashing), check the battery pack. See **Battery Pack Troubleshooting** in this chapter.
- B. Remove the cable to the I/O PCA (2225A, 2225D, or 2225P) and apply power again. If the printer then powers up correctly, the cable was not properly seated or the I/O PCA needs replacement.
- C. If the yellow light fails to blink, check the keypad and Main Logic PCA. See **Main Logic PCA Troubleshooting** in this chapter.
- D. If the yellow light stays on, it indicates a paper out condition. Check the out of paper switch and Main Logic PCA.
- E. If the yellow light continues blinking after power-on, it indicates a self test failure in the kernel of the Main Logic PCA.
- F. If the yellow light blinks twice, stays off for several seconds, and then resumes blinking, it indicates one of the following:
  - A failure in the Main Logic PCA.
  - A faulty carriage motor. See step G.
  - A faulty home switch.
  - The mechanism will not allow the carriage to move.

- G. If the carriage motor fails to move, disconnect the motor and plug another motor in its place (There's no need to actually mount the motor in the mechanism). If the new motor fails to rotate at power-on, check the Main Logic PCA. If the new motor rotates at power-on, verify that it can work in the mechanism. If not, check the mechanism for any type of binding (gear housing, carriage cable, etc.).
  - H. If the print head crashes to the left, check the home switch (opto sensor), Main Logic PCA, and mechanism for binding.
2. Push the LF key on the front panel a few times. Does the printer advance a line at a time? (Tapping the key should cause the mechanism to advance one dot row.) Does the paper drive operate smoothly? If the answer is yes, go to step 3.

If the printer fails to perform a line feed, do the following:

- A. Check the keypad to ensure the switch is functional. The easiest way to do this is by simply connecting a new keypad without actually mounting it to the top cover.
  - B. Disconnect the paper motor and plug another motor in its place. (There's no need to actually mount the motor in the mechanism.)
  - C. If the new motor fails to rotate when LF is pressed, check the Main Logic PCA. See Main Logic PCA Troubleshooting.
  - D. If the new motor rotates at power-on, verify that it can work in the mechanism. If not, check the mechanism for any type of binding (gears, bearings, etc.).
3. Push the FF key on the keypad. Does the printer advance the paper several inches? If not, replace the keypad and check the print mechanism for binding that would prevent paper from freely moving through the unit.
4. Run the printer's self test (power off, hold down LF or FF key, power-on, release key). The printer should print a test pattern similar to Figure 8-1. If the pattern is printed correctly, go to step 5.

If no printing occurs or dots are missing, check or replace the print head, proper connection of the carriage cable, and the Main Logic PCA. See Main Logic PCA Troubleshooting.

5. Connect a host computer to the printer and send data to the printer. If the printer prints the data correctly, the printer is considered OK. If no printing occurs, recheck both units for proper configuration. Then check or replace the following:
- I/O PCA
  - I/O cable
  - Main Logic PCA

## Main Logic PCA Troubleshooting

This procedure assumes the Main Logic PCA has a known fault and no other fault exists outside of the board. Use the following procedure as an aid in troubleshooting this PCA to the component level. This troubleshooting procedure includes "Troubleshooting the Kernel", "Troubleshooting the Carriage Motor Circuitry", "Troubleshooting the Home Switch Circuitry", and "Troubleshooting the Print Head Circuitry". See Chapter 12 for schematics of each ThinkJet printer PCA (Printed Circuit Assembly).

### Note



All troubleshooting must be done with paper installed.

1. To access the Main Logic PCA, remove the top cover and position the backpanel and mechanism to allow access the the PCA.
2. Check the applicable points in Table 8-1 to ensure the power circuitry is operating correctly.

Table 8-1. HP ThinkJet Voltage Levels

Voltage Supply	Nominal Voltage	Voltage Range
VDRAW	11.6 V	8.5 to 12.7 V
VDD	5.0 V	4.75 to 5.25 V
VMC (except 2225C)	24.0 V	23.04 to 24.96 V
VMC (2225C)	23.7 V	22.7 to 25.1 V
VMP (except 2225C)	34.7 V	27.0 to 40.0 V
VMP (2225C)	27.0 V	26.0 to 28.4 V
VHD (except 2225C)	22.68 V	22.5 to 22.86 V
Vhead (2225B & 2225P) & VHD (2225C)	22.7 V	22.5 to 22.93 V
NRESET	4.5 V	>4.5 V
VBATT (2225B & 2225P)	8.0 V	7.2 to 8.5 V
LBIC (2225B & 2225P)	Low	
LBIW (2225B & 2225P)	Low	
VIO (2225C)	4.9 V	4.75 to 5.25 V
-VDRAW (2225D)	-11.6 V	-8.5 to -12.7 V

## Note



---

If any parts are replaced in the power system, recheck the print head voltage (Vhead or VHD). Perform the power supply adjustment if measurement is out of specification.

---

3. At power-on with paper installed, does the yellow light blink twice and go out? If it does, it indicates that the CPU, ROM, RAM, carriage motor circuitry, and home switch circuitry are working correctly. In this case, go to step 4. If not, continue within step 3.

If the yellow light is always on, it indicates a problem in the paper sense circuitry. If the yellow light continues blinking after power-on, it indicates a self test failure in the kernel (ROM, RAM, or CPU). See *Troubleshooting the Kernel*. If the yellow light blinks twice, stays off for several seconds, and then resumes blinking, it indicates one of the following:

- The logic PCA is not driving the carriage motor. See *Troubleshooting the Carriage Motor Circuitry*.
- The home switch circuitry is not sending signals to the ThinkJet processor (CPU). See *Troubleshooting the Home Switch Circuitry*.

If the carriage motor moves twice through the home switch, as in a normal power-on sequence, it indicates the kernel and carriage motor circuits are working correctly. A blinking yellow light would then indicate a problem in the home switch circuitry. See *Troubleshooting the Home Switch Circuitry*. If this is not the case continue to the next section.

## Troubleshooting the Kernel

Check the 3MHz crystal for activity. Figure 8-2 shows the waveform on each leg of the crystal.

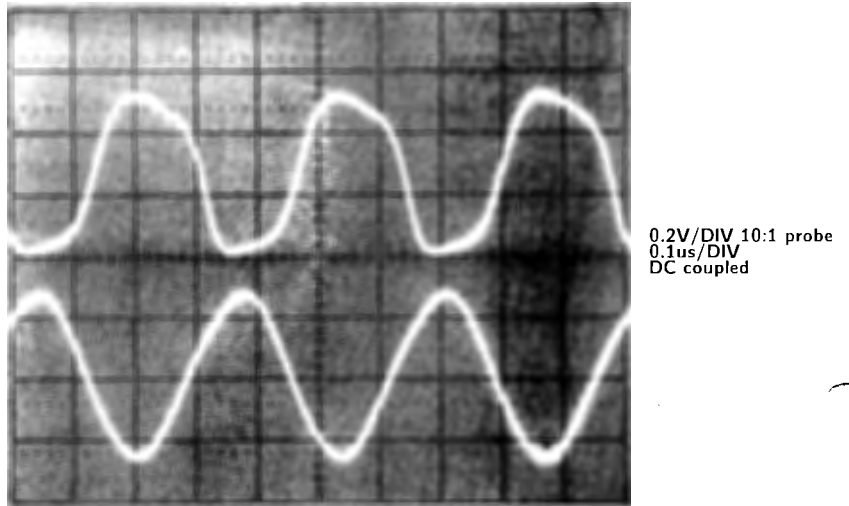

Figure 8-2. Crystal Waveform

The ThinkJet processor, also called CPU (U1 or U6, printer model dependent), has a built-in self test that runs during the power-on cycle. To monitor the result of the self test, a logic probe must be placed on one of several pins of the CPU while the unit is powered up. If the kernel has failed the self test, one of the pins will pulse to indicate the failure mode. The pins and meanings are shown in Table 8-2.

Table 8-2. Nonprinting Self Test Error Indication

CPU Pin Pulsing	Meaning
CPU Pin 16 (DOT 12)	CPU Faulty
CPU Pin 17 (DOT 11)	Internal ROM on CPU Faulty
CPU Pin 18 (DOT 10)	Internal RAM on CPU Faulty
CPU Pin 19 (DOT 9)	Timer on CPU Faulty
CPU Pin 22 (DOT 6)	RAM Faulty
CPU Pin 23 (DOT 5)	ROM Faulty



## Note



---

At power-on, each pin listed in Table 8-2 may pulse once as the CPU is being set. This first pulse occurs almost immediately and does not indicate an error message. Wait about one second for a second pulse, which will be a slightly longer pulse than the first.

---

To check each pin in Table 8-2:

- A. Place the logic probe on the appropriate CPU pin.
- B. Reset the CPU by turning the power switch off and on.
- C. Continue checking the pins, resetting the CPU each time.

If none of the pins indicate a failure, check the carriage motor circuitry.

## Troubleshooting the Carriage Motor Circuitry

The following procedure assumes that the kernel and power supplies have been checked and that a new carriage motor has been tried.

## Note



---

For future reference, one way to have the carriage motor run is to unplug the reed switch connector, remove the print cartridge, and invoke the printing self test.

---

- A. Ensure the blue key is functional. Place a logic probe on pin 43 of the CPU (ADV). The probe should indicate a high level as long as the key is held down.
- B. Check the CPU's carriage motor port by placing a logic probe on pins 4,5,6, and 7 of the CPU and press the blue key. Each carriage motor port pin should toggle several times. If any pin fails to toggle, replace the CPU. If all pins toggle, go to step C.
- C. Unplug the carriage motor. Check the carriage driver outputs by placing an oscilloscope probe on each pin of connector J4 and press the blue key. Each pin should toggle several times. If any pin fails to toggle, replace the carriage motor driver IC that connects to J4. If all pins toggle, go to step D.

On the 2225B and 2225P printers, check each drive transistor by placing the oscilloscope probe on the anodes of CR7-10 and press the blue key. The waveform should appear as a square wave about 8 volts high. (This requires current flow through the probe.) If not, replace the appropriate drive transistor or its associated flyback protection diode. (A shorted diode will force the node high; an open diode may cause the drive transistor to fail. Always check the diode when replacing a bad transistor.)

- D. If the waveform appears good, the problem is probably in the diode/capacitor circuit between pins 4 and 5 of J4 (except 2225C). A shorted diode or capacitor is very difficult to detect in normal operation. The result would be slight variations in the width of printed characters. With an open diode, the carriage would have difficulty moving and would stop after a few seconds.

**Note**



If one of these diodes is open, the corresponding capacitor must be replaced as well.

- E. Figures 8-3 through 8-6 show carriage motor circuitry waveforms under normal operating conditions as the carriage sweeps across the platen. Figures 8-3 and 8-4 apply to the 2225A, and 2225D. Figures 8-5 and 8-6 apply to the 2225B and 2225P printers.

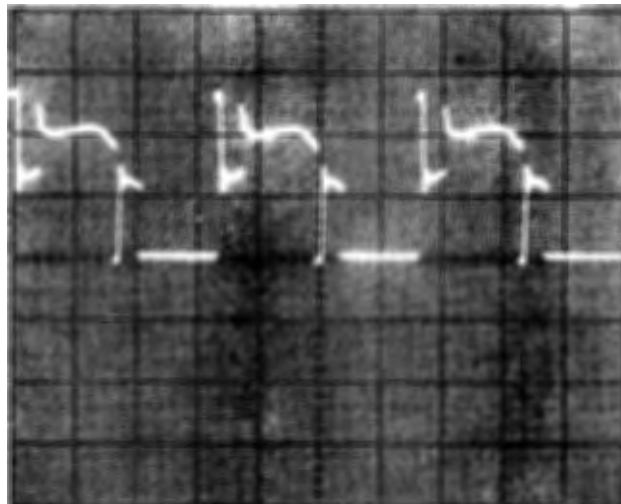

2V/DIV 10:1 probe  
2ms/DIV  
DC coupled

Figure 8-3. 2225A/C/D at Connector J4 Pins 1-4

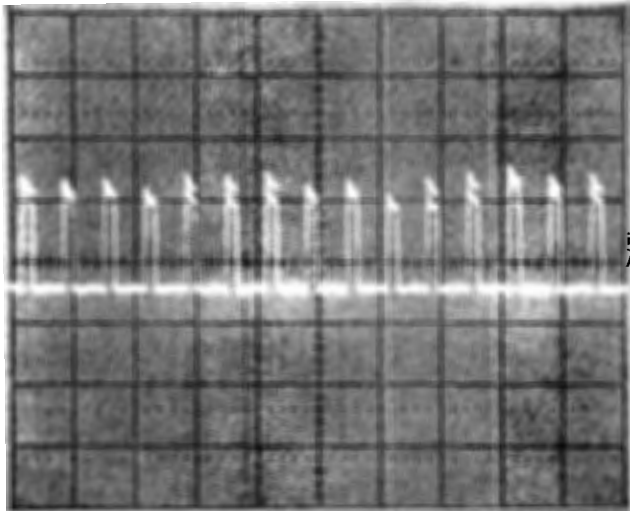

2V/DIV 10:1 probe  
5ms/DIV  
AC coupled

Figure 8-4. 2225A/C/D at Connector J4 Pin 5

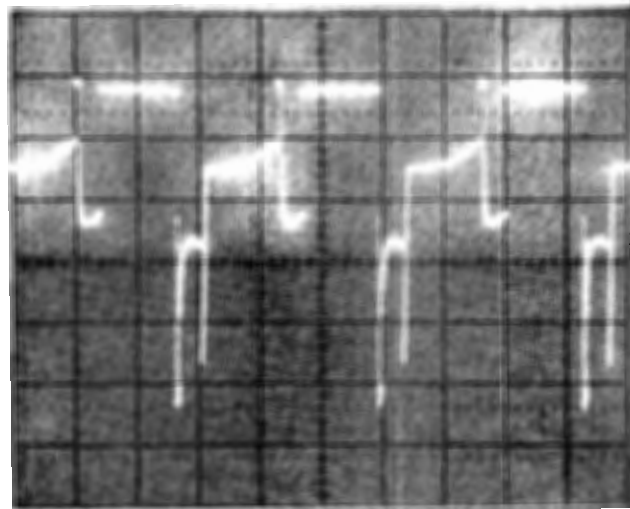

1V/DIV 10:1 probe  
2ms/DIV  
DC coupled

Figure 8-5. 2225B/P at Connector J4 Pins 1-4

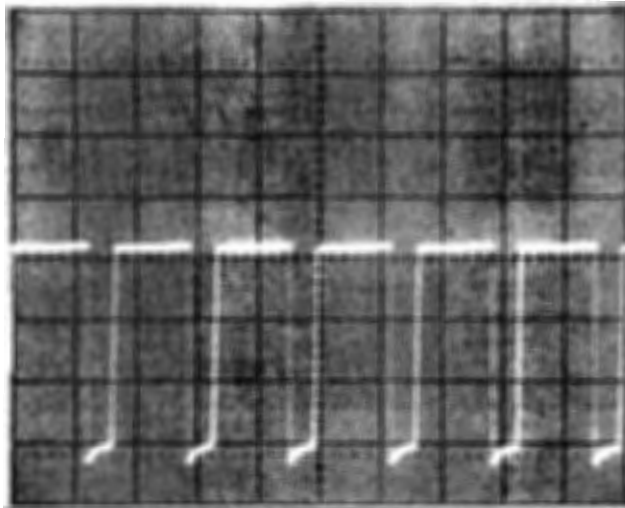

.5V/DIV 10:1 probe  
2ms/DIV  
DC coupled

Figure 8-6. 2225B/P at Connector J4 Pin 6

## Note



---

Remember that under failed conditions, voltages will be induced back on the collector of a bad transistor because two motor phases are tied together.

---

## Troubleshooting the Home Switch Circuitry

When the home switch circuitry is faulty, the typical symptom is that the carriage will move initially to the right, reverse direction and crash into the left sideframe for a few seconds, and then come to rest. Do not attempt to troubleshoot this circuitry until the carriage is capable of moving through the home switch. Failure to move the carriage indicates the problem is located elsewhere.

- A. Ensure the blue key is functional. Place a logic probe on pin 43 of the CPU (ADV) and press the blue key. The probe should indicate a high level as long as the key is held down.
- B. With power on and a known good home switch installed, place a logic probe on pin 46 of the CPU (HPE) and press the blue key on the keypad. This line from the CPU is the light enable signal; it should pulse high for about two seconds and then return low. If good, go to step C. If not, replace the CPU.
- C. Place an oscilloscope probe on J5(2) and press the blue key again. The voltage level should go low for about two seconds and then return high, indicating the light enable signal passed through the driver. If good, go to step D. If not, replace U9.

- D. Check that the voltage on J5(3) is about 5.0 volts. If good, go to step E. If not, check the comparator connected to J5(3) and associated resistors.
  - E. Check that pin 45 on the CPU (HSD) is a logical low. Pushing the blue key should cause it to pulse high several times, indicating the home switch circuitry is working properly. If good, suspect the CPU. If not, suspect the comparator between the CPU pin 45 and connector J5.
4. Check the paper advance circuitry by pressing the LF and FF keys. If paper advances normally, go to step 5. If not, use the following information to troubleshoot this portion of the Main Logic PCA. This procedure assumes that a new paper motor has been tried.
- A. Ensure the FF key is working properly. Place a logic probe on J7(3) and press the FF key. The pin should go high for as long as the key is held down and then return low.
  - B. Ensure the LF key is working properly. Place a logic probe on pin 2 and 43 of the CPU and press the LF key. Each pin should go high for as long as the key is held down and then return low.
  - C. Check the CPU's paper motor port by placing a logic probe on each input pin of the port latch and then pressing the LF key. Each pin should toggle several times. If any pin fails to toggle, replace the CPU. If all pins toggle, go to step D.
  - D. Check the paper motor port latch output by placing an oscilloscope probe on each output pin and pressing the LF key for a few seconds. Each pin should toggle several times. If any pin fails to toggle, replace the appropriate IC. If all pins toggle, go to step E.

On the 2225B or 2225P, check each drive transistor circuit (Q7-10) by placing an oscilloscope probe on the anodes of CR3-6 and pressing the FF button. The waveform should appear as that shown in Figure 8-7. If any output fails to toggle, replace the appropriate drive transistor or its respective flyback protection diode. (A shorted diode would force the node high; an open diode may cause the driver transistor to fail. Always check the diode if a transistor is bad.) Remember that under failed conditions, voltages will be induced back on the collector of a bad transistor because two motor phases are tied together.

-15

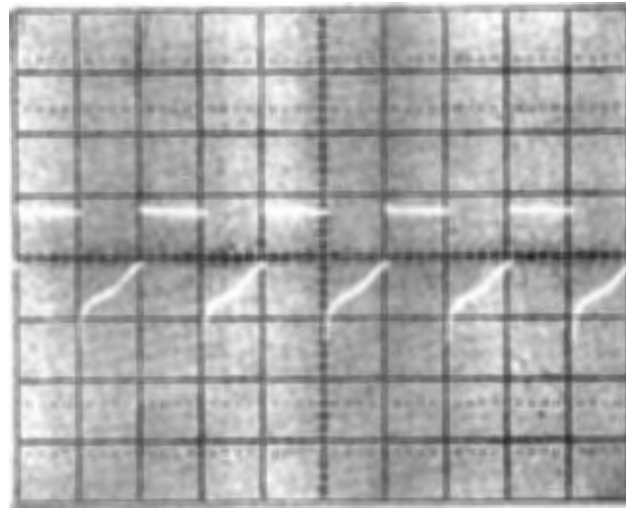

1V/DIV 10:1 probe  
10ms/DIV  
DC coupled

Figure 8-7. Transistor Q7-10 Waveform

5. The next step is to run the print mechanism self test to determine if the unit is capable of printing on its own. Turn off power to the printer, select Roman8 character set, hold the LF key down, power the printer on, wait a few seconds and then release the LF key. The unit should begin printing a self test pattern as shown in Figure 8-1. If the printout is correct, go to step 6. If not continue in the following section.

### Troubleshooting the Print Head Circuitry

In troubleshooting the print head circuitry, it is assumed the problem is not in the print head or carriage assembly.

Run the printing self test while using the logic probe to check CPU pins 16-27. Each pin should toggle as the unit attempts to print.

Note



The top print head dot (J2(7)) and bottom two print head dots (J2(4) and J2(5)) only toggle during a few of the printed lines. Be sure the Roman8 character set is selected prior to running the self test.

Note



If any of the lines fail to toggle, replace the CPU. If all lines toggle, the problem is in U8 or U9. Run the test again and use an oscilloscope to look for activity on the print head latch output pins. The waveform should appear as narrow, negative-going pulses from about 24 volts to logic ground. Replace the defective IC.

6. The last item to check is the I/O circuitry. Assuming the I/O PCA has been checked, the probable cause is the CPU or control line logic circuitry.

---

## Battery Pack Troubleshooting

Insert the battery pack into a printer and observe the keypad PWR and yellow "attention" lights. They should behave in one of the following ways.

1. **No lights on.** The battery pack has extremely low voltage. Remove the pack and measure the voltage from the middle (ground) to the positive (side) terminal. If the problem is in the battery pack, the voltage will probably be less than 6 volts. Attempt to recharge the pack with a standard recharger. If the pack is functional but badly discharged, the voltage will rise from the initial value to roughly 7.5 volts during the first 5 to 30 minutes. Note that this is initially a somewhat inflated voltage due to the presence of the recharger. If this initial surge of voltage slows or stops much before 7.5 volts, a shorted cell may be indicated. Since each cell has a voltage of about 1.25 volts, this will be indicated by a 6.2 or 5 volt final level.

If the battery has an open circuit failure such as a blown fuse or mechanical fault, the voltmeter will show the pure recharger voltage which is between 10 and 12 volts. This will drop to very near 0 volts when the recharger is disconnected. After the initial voltage rise, the voltage of a good battery pack will rise to a final "overcharge" voltage of about 8.5 volts. When the battery is fully charged, it stops storing the incoming energy and begins converting it all into heat. Thus, the most certain indication that the battery is fully charged is that it becomes slightly warm. The 8.5 volt "overcharge" voltage is partially a function of the charging process. After a small amount of discharge, the voltage will drop to the 7.2 to 7.6 volt range where it will remain for most of its charge life.

2. **The yellow indicator light flashes twice, the red PWR light stays off, and the carriage stalls during start-up.** This probably indicates that the battery is only partially charged, so the printer can perform its internal self test but does not have enough power for normal operation. The open-circuit voltage is probably between 5.7 and 7.2 volts. This may be due to a normal discharge condition after extended use.
3. **The yellow light flashes continuously, but the red PWR light stays off.** This indicates that the battery has enough voltage to start the printer but cannot maintain this voltage during the attempt to accelerate the motor. The printer is thus reset as soon as the attempt is made to "seek and home" and immediately launches into another self test, ad infinitum. This can be caused by a malfunctioning or extremely discharged battery that is capable of being falsely inflated to a high voltage, but which will not maintain high currents.

4. **The red PWR light is on the the yellow light is flashing.** This condition indicates that the printer has failed the nonprinting self test.
5. **Red PWR light flashes while the printer is idle.** This is a warning that the battery level is low and needs charging. If the battery level drops below the cutoff state, the Centronics interface BUSY line is set true, inhibiting data transmission.

## Battery Level Hysteresis

Table 8-3 shows the two threshold points for low battery pack level indication. Latches in the printer are set when the battery level drops to these two trigger points. To reset these latches and remove the PWR light flashing or off condition, the battery level must raise above the latch set point to the reset point. This difference in set and reset is known as hysteresis.

Table 8-3. Battery Pack Level Indication

PWR Light Indication	2225B Battery Level	2225P Battery Level
PWR Light On	Above 6.5 Volts	Above 6.8 Volts
PWR Light Flashing	6.2 to 6.5 Volts	6.7 to 6.8 Volts
PWR Light OFF	Below 6.2 Volts	Below 6.7 Volts



## Troubleshooting Hints

Table 8-4. Troubleshooting Hints

Symptom	Possible Cause
Missing dots.	<ol style="list-style-type: none"><li>1. Print head needs cleaning</li><li>2. Print head defective</li><li>3. Print head cable/connector.</li><li>4. Logic PCA.</li></ol>
Print is too light.	<ol style="list-style-type: none"><li>1. Unspecified paper.</li><li>2. Wrong side of paper.</li><li>3. Running out of ink.</li><li>4. Logic PCA.</li></ol>
Printer will not advance paper.	<ol style="list-style-type: none"><li>1. Paper motor or connector</li><li>2. Logic PCA.</li><li>3. I/O PCA (2225A/D).</li><li>4. Bail arm adjustment (early version).</li><li>5. Tractor pinwheels.</li><li>6. Paper path.</li></ol>
Carriage slams into side plate when homing	<ol style="list-style-type: none"><li>1. Carriage motor or connector.</li><li>2. Home switch assembly</li><li>3. Logic PCA</li><li>4. Wear shoe on carriage.</li></ol>
Carriage stalls before done homing (yellow light flashing)	<ol style="list-style-type: none"><li>1. Drum cap on cable assembly</li><li>2. Gear box for carriage drive.</li><li>3. Idler pulley</li><li>4. Wear shoe on carriage.</li></ol>
Paper out condition indicated with paper installed.	<ol style="list-style-type: none"><li>1. Out of paper switch</li><li>2. Logic PCA</li><li>3. I/O PCA (2225A/D).</li></ol>



Table 8-4. Troubleshooting Hints (Cont.)

Symptom	Possible Cause
Controller indicates loop time-out or errors (2225B/P).	<ol style="list-style-type: none"> <li>1. Logic PCA</li> <li>2. HP-IL connector assembly</li> <li>3. Battery</li> </ol>
Locks up controller, nothing printed (2225A/D).	<ol style="list-style-type: none"> <li>1. I/O PCA.</li> <li>2. Logic PCA.</li> <li>3. I/O to Logic flex cable.</li> </ol>
Turns on, red light on (or flashing on 2225B), no homing, no yellow light.	<ol style="list-style-type: none"> <li>1. Carriage motor or connector.</li> <li>2. Battery (2225B only).</li> <li>3. Keypad switch assembly.</li> <li>4. I/O PCA (2225A/D).</li> <li>5. Controller off or resetting printer.</li> </ol>
Carriage stalls while printing.	<ol style="list-style-type: none"> <li>1. Carriage motor.</li> <li>2. Logic PCA.</li> <li>3. Gear box for carriage drive.</li> <li>4. Carriage binding</li> </ol>
Printer is noisy while printing.	<ol style="list-style-type: none"> <li>1. Carriage motor.</li> <li>2. Gear box for carriage drive</li> </ol>

---

## Notes

## Introduction

This chapter lists replaceable parts and assemblies for the HP ThinkJet Printer. For printer accessory part numbers, see Table 1-1, HP ThinkJet Accessories. Each parts list is referenced to a figure for part identification. This chapter includes the following parts lists:

- **HP 2225A HP-IB ThinkJet Parts Lists**
  - Table 9-1. Overall Parts List
  - Table 9-2. Main Logic PCA Parts List
  - Table 9-3. I/O PCA Parts List
- **HP 2225B HP-IL ThinkJet Parts Lists**
  - Table 9-4. Overall Parts List
  - Table 9-5. Main Logic PCA Parts List
- **HP 2225C Centronics ThinkJet Parts Lists**
  - Table 9-6. Overall Parts List
  - Table 9-7. PCA Parts List
- **HP 2225D RS-232C ThinkJet Parts Lists**
  - Table 9-8. Overall Parts List
  - Table 9-9. Main Logic PCA Parts List
  - Table 9-10. I/O PCA Parts List
- **HP 2225P Battery Centronics ThinkJet Parts Lists**
  - Table 9-11. Overall Parts List
  - Table 9-12. Main Logic PCA Parts List
  - Table 9-13. I/O PCA Parts List
- **HP ThinkJet Printer Mechanism**
  - Table 9-14. Mechanism Parts List

---

### Note



For outdated ThinkJet Printer replaceable parts lists, see Chapter 11, "Product History".

---

---

## Ordering Information

To order replaceable parts, assemblies, or accessories, contact your local Hewlett-Packard Sales and Service Office. A list of Hewlett-Packard Sales and Service Offices can be found prior to the index. Include the following information for each part ordered:

1. Complete printer model and serial number.
2. Hewlett-Packard part number.
3. Complete part description as provided in the replacement parts lists.

**HP 2225A  
Overall**

Table 9-1. 2225A Overall Parts List

Figure Reference	Part Description	Part Number	Qty
1	Paper Separator (order front cover/window)	02225-40032	1
2	Case, Top	02225-40028	1
3	Front Cover/Window (order paper separator)	02225-40025	1
4	Window Label	02225-80097	1
5	Screw	0624-0621	5
6	Motor, Carriage	3140-0786	1
7	Mechanism Assembly	02225-60901	1
8	Mechanism Washer	02225-00017	2
9	Motor, Paper	3140-0788	1
10	Screw, Paper Motor	0515-1268	2
11	Print Cartridge (black)	92261A	1
12	Plate, Gnd	02225-00019	1
13	Foot	02225-00010	4
14	Case, Bottom	02225-40027	1
15	Main Logic PCA		
	Model 2225A	02225-60062	1
	Model 2225AJ	02225-60063	1
	Model 2225AT	02225-60064	1
	Model 2225AV	02225-60065	1
16	Screw	2360-0495	6
17	Washer	2190-0757	3
18	Screw	3030-0252	1
19	Ground Strap	02225-80091	1
20	Nut	0590-0305	1
21	Fuse	2110-0621	1
22	Transformer	9100-4384	1
23	Screw, Transformer Mounting	0624-0638	2
24	I/O PCA Mounting Stud	0624-0625	4
25	I/O PCA Standoff	0380-1774	4
26	HP-IB I/O PCA	02225-60011	1
27	Washer	2190-0108	4
28	Nut, 4-40	2340-0001	1
29	Cable, I/O PCA	8120-4435	1
30	I/O Connector Standoff	0380-0643	2

Table 9-1. 2225A Overall Parts List (Cont.)

Figure Reference	Part Description	Part Number	Qty
31	HP-IB Backpanel Assy	02225-60013	1
	which includes:		
32	Fuse Box	9135-0238	1
33	Power Switch	3101-2729	1
34	Keypad Switch Assy	02225-60904	1
35	Screw, Keypad	0624-0620	2
36	Switch Overlay	02225-80007	1
37	Screw, Top Cover	0624-0616	4
	Print Structure Assy	02225-60902	N/A
	Backpanel Fuses/Fuseholders		
	Fuse, 400mA	2110-0340	1
	Fuse, 250mA	2110-0489	1
	Fuse, 200mA	2110-0588	1
	Fuse, 100mA	2110-0202	1
	Fuseholder, US	2110-0686	1
	Fuseholder, European	2110-0687	1

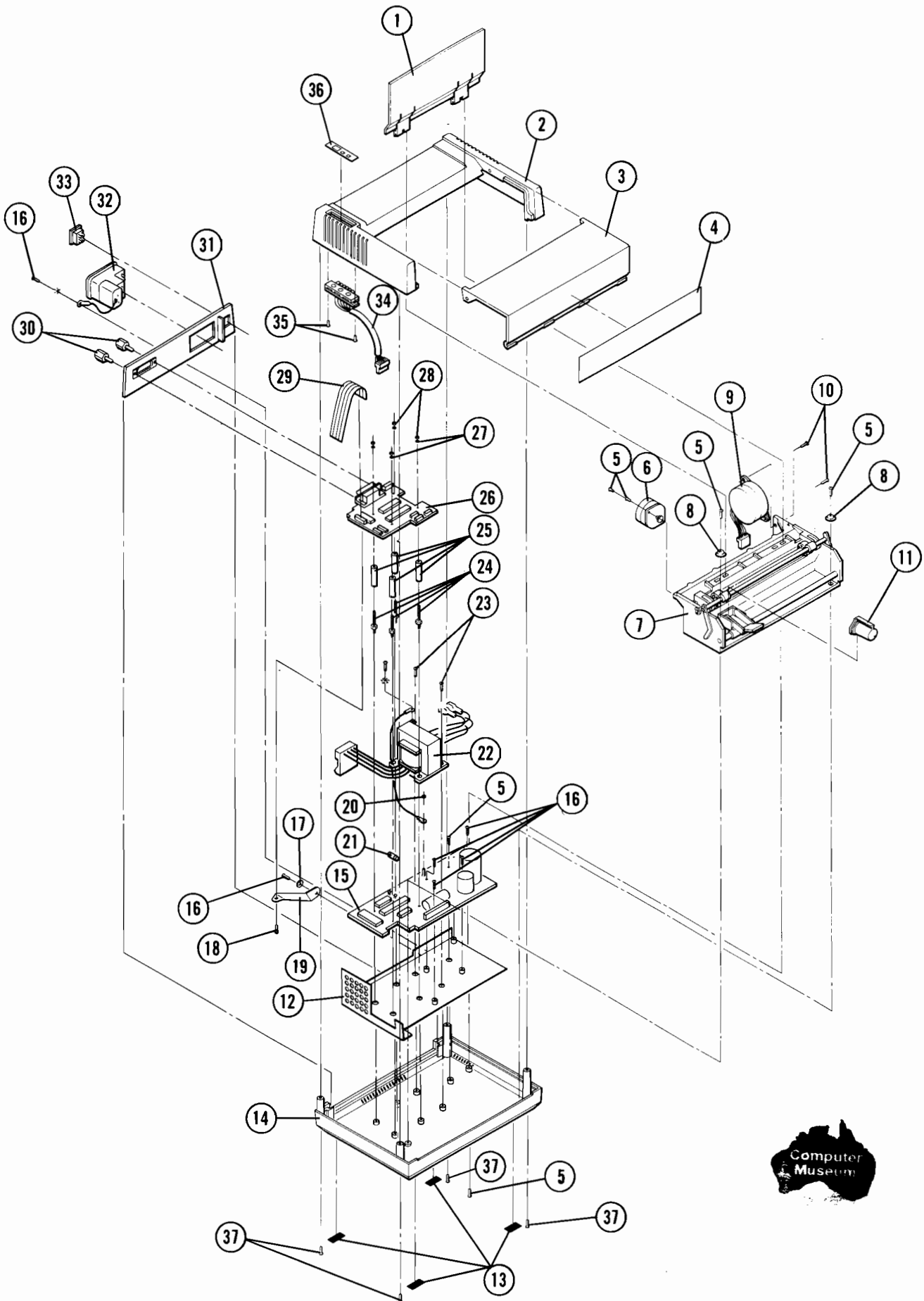

Figure 9-1. HP 2225A ThinkJet Printer Overall View

# HP 2225A Main Logic PCA

Table 9-2. 02225-60062,60063, & 60064

Figure Reference	Part Description	Part Number	Qty
C1	CAP 470uF 50V	0180-3451	1
C2	CAP 4700uF 16V	0180-3162	1
C6-9,16,33-35	CAP .01uF 20%	0160-4554	8
C10	CAP 33uF 16V 20%	0180-2951	1
C15	CAP 1uF 50V 20%	0180-3314	1
C17	CAP 33pF 5% 100V	0160-4807	1
C18	CAP 10pF 5% 100V	0160-4791	1
C38	CAP 330uF 35V 20%	0180-3450	1
	CAP 680uF 35V	0180-3856	1
CR1,2,5,6	DIO	1901-1185	4
CR3,4,7,8	DIO PWR 400V	1901-0731	4
CR9-13	DIO 1N4150	1901-1098	5
F1	Fuse .5A 250V TD	2110-0621	1
J2	CONN Flex Ckt 13	1251-8530	1
J3,4,7	CONN ML 6 Pin	1251-8089	3
J5	CONN 4 Cont Post	1251-7018	1
J6	CONN 2 Cont Post	1251-6427	1
J8	CONN 4P MTA	1251-8958	1
J9	CONN TP-TP Entry	1252-1614	1
MP1,2	Heat Sink	1205-0576	2
MP4,5	FUSEHLDR Clip 10A	2110-0589	2
R1	RES 237 Ohm 1%	0698-3442	1
R2	RES 4.22K 1%	0698-4645	1
R3,4	RES 1M 5% .25W	0683-1055	2
R5	RES 26.7K .1%	0698-6519	1
R7	RES 47 Ohm 5%	0683-4705	1
R6	RES 9.9K .1%	0698-6321	1
R10	RES 4.7K 5% .25W	0683-4725	1
R11	RES 10K 1%	0757-0442	1
R12	RES 10K 5% .25W	0683-1035	1
R14	RES 261K 1%	0698-3455	1
R15	RES 130K 1%	0757-0468	1
R16	RES 64.9K 1%	0698-4502	1
R21	RES 1.5K 5% .25W	0683-1525	1
R22	RES 39K 5% .25W	0683-3935	1
R23,24	RES 680 Ohm 5%	0683-6815	2
R25,26	RES 100K 5%	0683-1045	2
R27	RES 10M 5% .25W	0683-1065	1
R30	619 Ohm 1% 1/8W	0757-0418	1

Table 9-2. 02225-60062,60063, & 60064 (Cont.)

Figure Reference	Part Description	Part Number	Qty
U1	CPU	1LJ7-0017	1
U2	IC 1K RAM	1LK4-0001	1
U3	IC ROM		
	Model A	1LG7-0064	1
	Model AJ	1LG7-0080	1
	Model AT	1LG7-0079	1
	Model AV	1LG7-0078	1
U7	IC 393	1826-0412	1
U8,9	XSTR Array 7NPN	1858-0099	2
U10	IC ULN 2023A	1858-0097	1
VR1	IC LM317T	1826-0393	1
VR3	IC, Volt Reg 7805	1826-0122	1
VR6	DIO Zener 6.8V 5%	1902-0954	1
VR7	IC LM385BZ	1826-1360	1
VR8	DIO Zener 33V 5%	1902-0970	1
VR9,15	DIO Zener 45.3V 5%	1902-0038	2
VR13	IC MC7824CT	1826-1218	1
VR14	DIO Zener 27V 5%	1902-0968	1
VR20	1N4752A	1902-0654	1
VR21	DIO Zener 40.5V	1902-1503	1
W5	Jumper Assy	1258-0228	1
Y1	Xtal 3MHz	0410-1496	1
	Screw	2360-0495	2



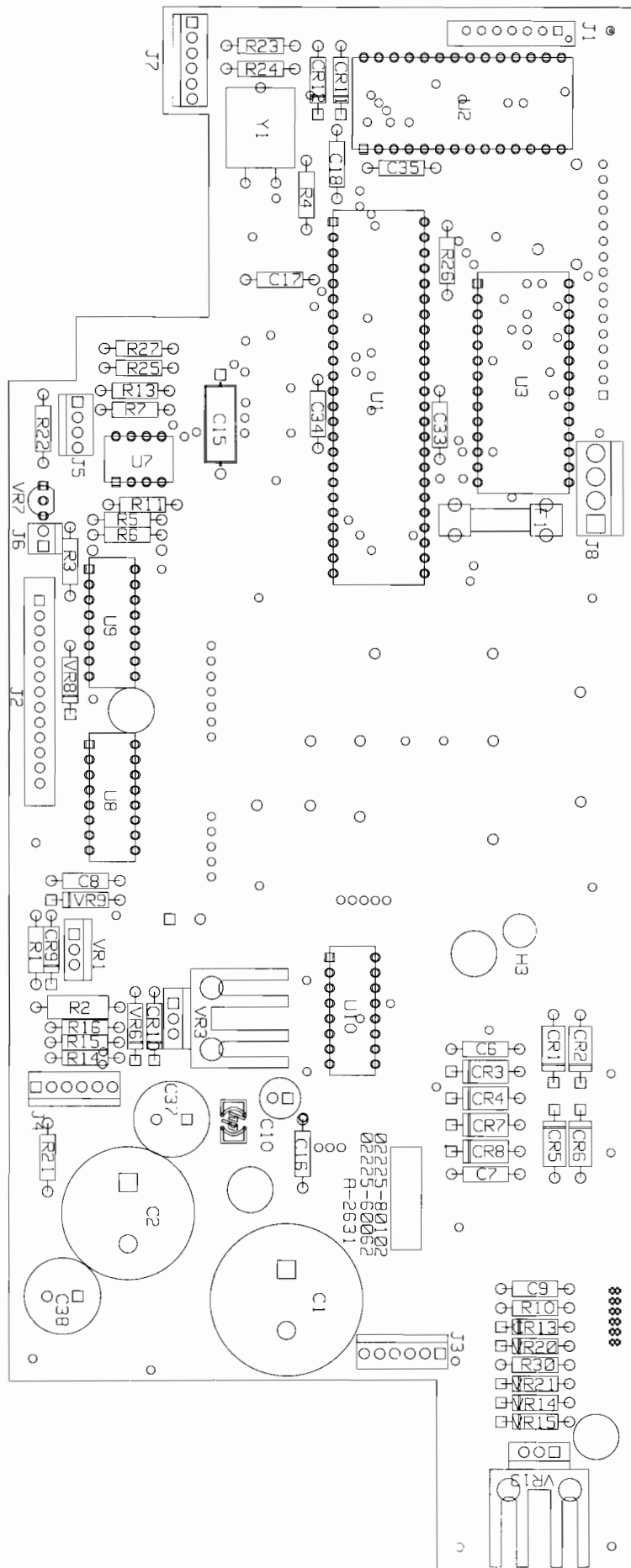

Figure 9-2. HP 2225A Main Logic PCA Assembly Drawing

**HP 2225A I/O  
PCA**

Table 9-3. 02225-60011

Figure Reference	Part Description	Part Number	Qty
C1	CAP 120pF 5%	0160-4800	1
C2-5,9-13	CAP 1uF 10% 50V	0160-4835	9
C6,7	CAP 22pF 5%	0160-3875	2
C8	CAP 33uF 16V 20%	0180-2951	1
C14	CAP 220uF 16V 20%	0180-2979	1
J1	CONN	1251-7651	1
J2	CONN 7P TP	1252-1614	1
L1	INDUCTOR 56uH 5%	9100-1631	1
MP1,2	SCR-SKT HD 5" LG	3030-0252	1
R1	RES Network 4.7K 2%	1810-0279	1
R2	RES 51.1K 1%	0757-0458	1
R3	RES NET 4.7K x 5	1810-0367	1
R4	RES 6.19K 1%	0757-0290	1
S1	SWITCH, Rocker 7-1A	3101-2215	1
U1	IC HPIL	1LB3-0003	1
U2,5	IC MC74C175N	1820-1562	2
U3	IC 80C96	1820-3545	1
U4	IC 8048L	1820-3636	1
U6	IC HP-IB Driver	1LH4-0001	1
U7	IC MM74C04N	1820-2211	1
U8	IC SN74LS03N	1820-1198	1
W1-3	RES Zero Ohms	8159-0005	3
Y1	Crystal 6MHz	0410-1414	1

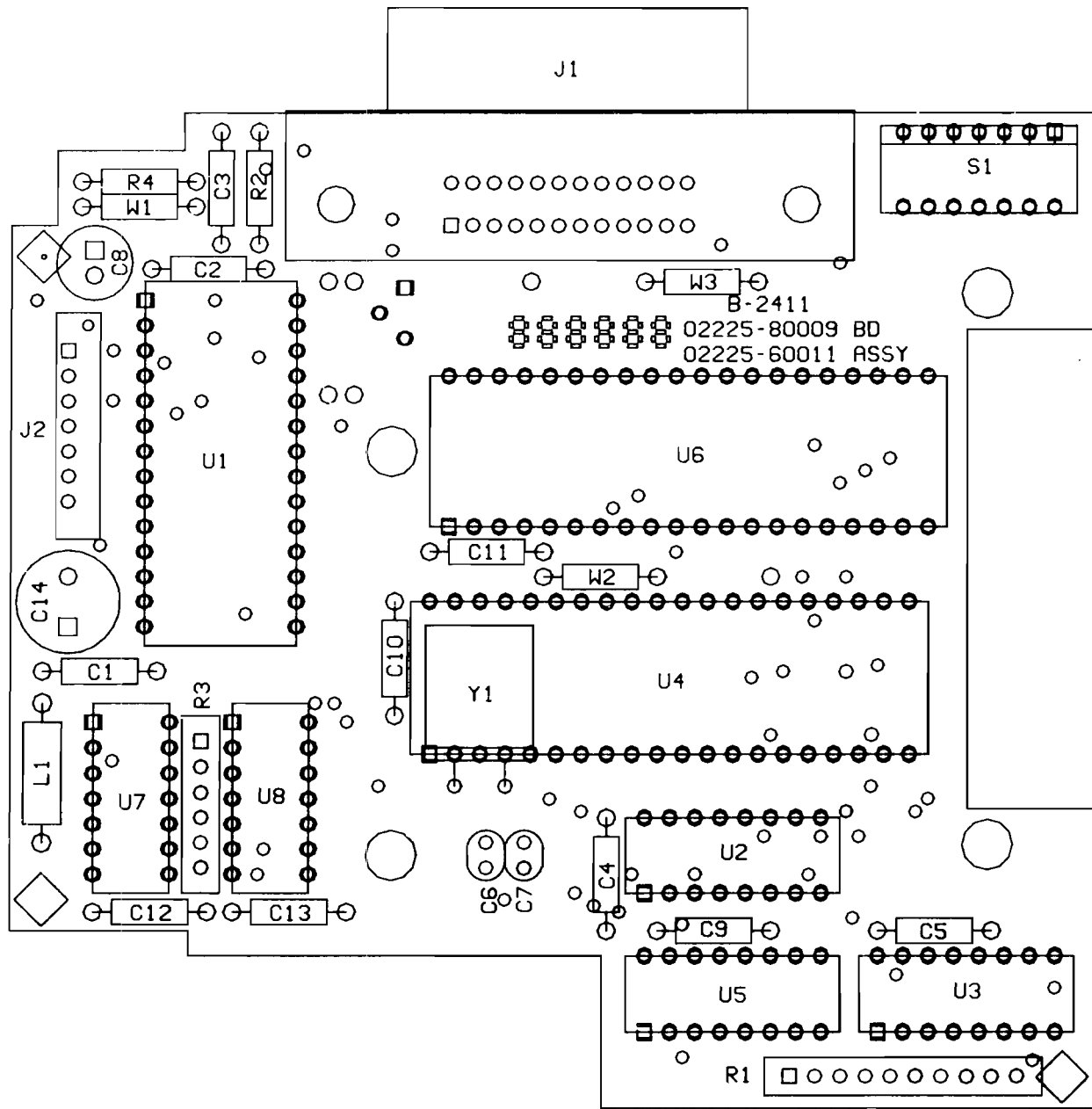

Figure 9-3. 02225-60011 Assembly Drawing

# HP 2225B Overall

Table 9-4. HP 2225B Overall Parts List

Figure Reference	Part Description	Part Number	Qty
1	Paper Separator (order front cover/window)	02225-40032	1
2	Case, Top	02225-40028	1
3	Front Cover/Window (order paper separator)	02225-40025	1
4	Window Label	02225-80097	1
5	Screw	0624-0621	8
6	Motor, Carriage	3140-0785	1
7	Service Mechanism Assy	02225-60901	1
8	Mechanism Washer	02225-0017	2
9	Motor, Paper	3140-0787	1
10	Screw, Paper Motor	0515-1268	2
11	Print Cartridge	92261A	1
12	Plate, Gnd	02225-00011	1
13	Foot	02225-00010	4
14	Case, Bottom	02225-40027	1
15	Main Logic PCA	02225-60001	1
16	Screw	2200-0216	4
17	Standoff	02225-40039	2
18	HP-IL Backpanel Assy which includes	02225-60012	1
19	Screw		2
20	HP-IL Interface Connector		1
21	Power Switch	3101-2736	1
22	Screw	0624-0617	2
23	Battery Pack	02225-60005	1
24	Keypad Switch Assy	02225-60904	1
25	Screw, Keypad	0624-0620	2
26	Switch Overlay	02225-80007	1
27	Screw, Top Cover	0624-0616	4
	Print Structure Assy	02225-60902	N/A

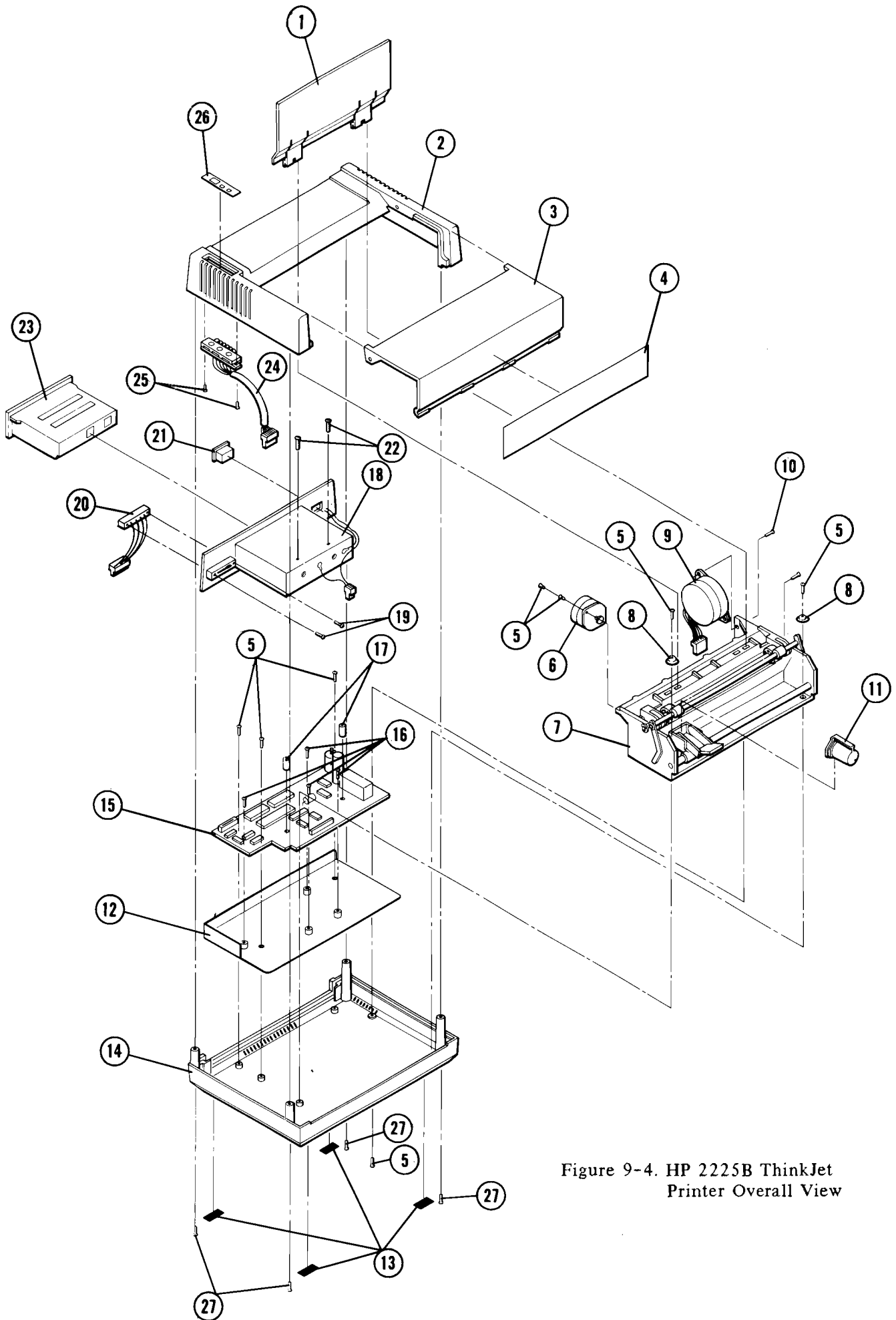

Figure 9-4. HP 2225B ThinkJet  
Printer Overall View

# HP 2225B PCA

Table 9-5. 02225-60001

Figure Reference	Part Description	Part Number	Qty
C1	CAP 320pF 1%	0140-0226	1
C2,27,28,30,33	CAP .01uF 20%	0160-4554	5
C3	CAP 1500pF 5%	0160-4846	1
C4	CAP 330uF 38V 100%	0180-3448	1
C5	CAP 100uF 10V 50%	0180-3155	1
C6,8,34,35	CAP 1uF 50V 20%	0180-3314	4
C7	CAP .1uF 5% 50V	0160-5471	1
C9	CAP .1uF 10% 50V	0160-4835	1
C11,12	CAP 220pF 5%	0160-4812	2
C25	CAP 33pF 5% 100V	0160-4807	1
C26	CAP 10pF 5% 100V	0160-4791	1
C31	CAP 33uF 16V 100%	0180-3449	1
CR2	DIO PWR 50V	1901-0789	1
CR3-10	DIO 1N4934	1901-0693	8
CR11,12	DIO 1N4150	1901-1098	2
J1,5	CONN 4 Cont Post	1251-7018	2
J2	CONN Flex Ckt 13	1251-8530	1
J3,4,7	CONN ML 6-Pin	1251-8089	3
J6,8	CONN 2 Cont Post	1251-6427	2
L1	INDUCTOR 180uH	9140-0843	1
MP1	Screw, 4-40 x 1.25	2280-0219	1
MP2	Nut, 4-40	2340-0001	1
Q3	XSTR NPN 2N3904	1854-0215	1
Q4	XSTR PNP 2N4403	1853-0271	1
Q5	TRANS TIP 41A	1854-0456	1
Q7-14	TRANS PNP TIP 32	1853-0537	8
R1	RES 12K 5%	0683-1235	1
R2,14,17	RES 100K 1%	0757-0465	3
R3	RES 4.53K 1%	0698-4443	1
R4	RES 90.9K 1%	0757-0464	1
R5	RES 38.3K 1%	0698-3161	1
R6,16,21	RES 10K 5% .25W	0683-1035	3
R7	RES 470 5% .25W	0683-4715	1
R8	RES 22.6K 1%	0757-0349	1
R9	RES 46.4K 1%	0698-3162	1
R10	RES 2.87K 1%	0698-3151	1
R11	RES 51.1 1% .125W	0757-0394	1
R12	RES 6.81K 1%	0757-0439	1

Table 9-5. 02225-60001 (Cont.)

Figure Reference	Part Description	Part Number	Qty
R13	RES 38.3 1%	0698-3435	1
R15	RES 1.05K 1%	0698-4467	1
R18	RES 4.32K 1%	0757-0436	1
R19	RES 26.7K .1%	0698-6519	1
R20	RES 9.9K .1%	0698-6321	1
R22,24	RES 20K 1%	0757-0449	2
R23	RES 47 5%	0686-4705	1
R30,34	RES 820 5% .25W	0683-8215	2
R31,32	RES 180 Ohm 5%	0683-1815	2
R33	RES 100K 5%	0683-1045	1
R35	RES 220 Ohm 5%	0683-2215	1
R36	RES 39K 5% .25W	0683-3935	1
R37-40	RES 46.4 1% .5W	0698-3398	4
R41-44	RES 60 1% .25W	0757-1042	4
R45	RES-NET 1K 2%	1810-0275	1
R48	RES 10M 5% .25W	0683-1065	1
R55	RES 42.2K 1%	0698-3450	1
R56	RES 78.7K	0698-4508	1
R57	RES 137K 1%	0698-4518	1
R59,60	RES 1M 5% .25W	0683-1055	1
T1	TRANSFORMER 3V	9100-4334	1
U1	IC Timer 555	1826-0180	1
U3	IC Linear LM339	1826-0138	1
U4	IC LM330T 5.0	1826-0904	1
U5	IC 393	1826-0412	1
U6	IC CPU	1LJ7-0017	1
U7	IC 1K RAM	1LK4-0001	1
U8-10	XSTR ARRAY 7 NPN	1858-0099	3
U11	IC ROM	1LG7-0064	1
VR1-6	DIO ZNR 33V 5%	1902-0970	6
VR10	IC LM385BZ	1826-1360	1
VR12,13	DIO ZNR 16V 5%	1902-0783	2
Y1	XTAL 3MHz	0410-1496	1

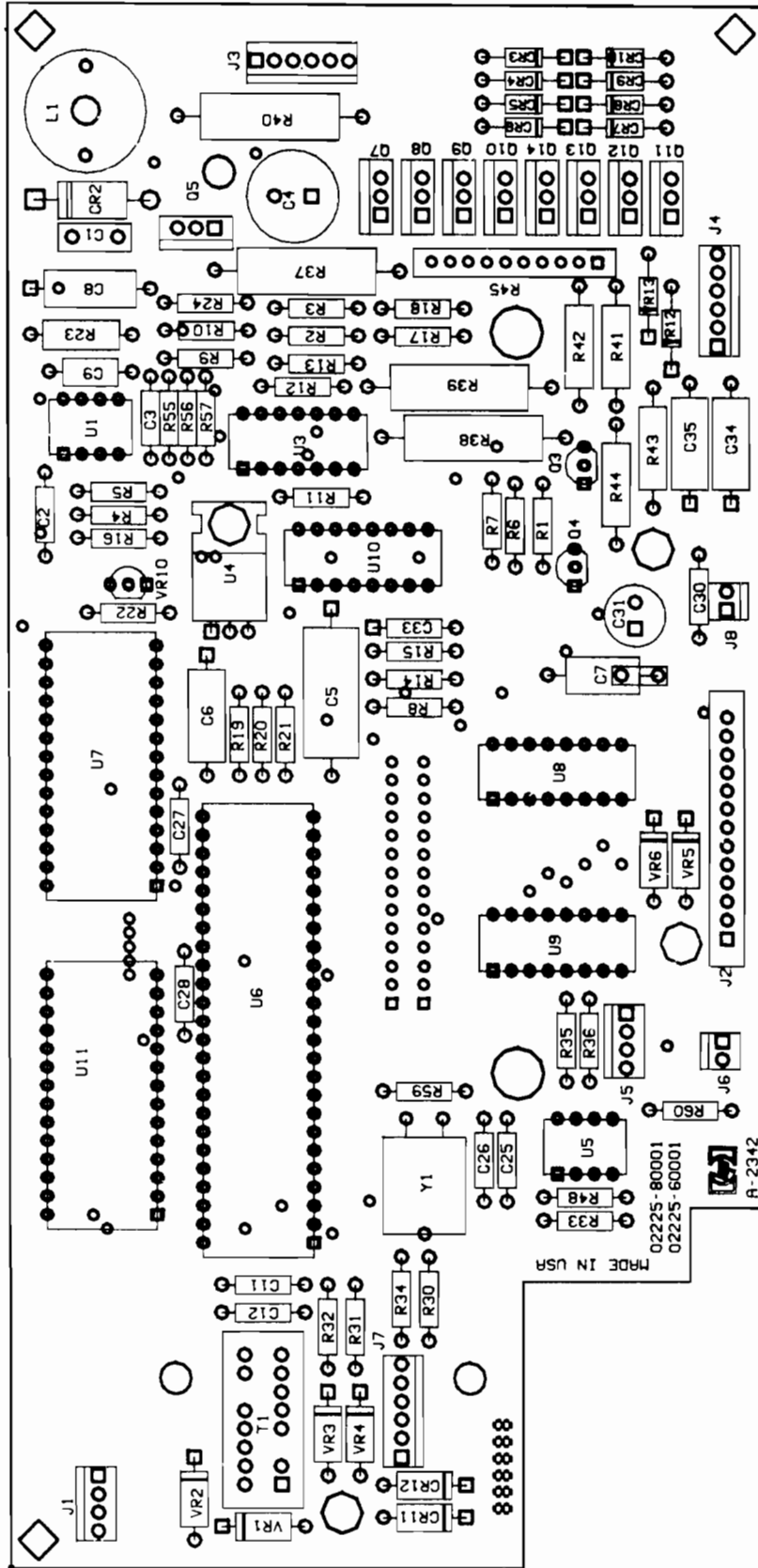

Figure 9-5. HP 2225B PCA Assembly Drawing



# HP 2225C Overall

Table 9-6. HP 2225C Overall Parts List

Figure Reference	Part Description	Part Number	Qty
1	Paper Separator (order front cover/window)	02225-40032	1
2	Case, Top	02225-40028	1
3	Front Cover/Window (order paper separator)	02225-40025	1
4	Label	02225-80038	1
5	Screw	0624-0621	5
6	Motor, Carriage	3140-0786	1
7	Service Mechanism Assy	02225-60901	1
8	Mechanism Washer	02225-0017	2
9	Motor, Paper	3140-0788	1
10	Screw, Paper Motor	0515-1268	2
11	Print Cartridge	92261A	1
12	Plate, Gnd	02225-00021	1
13	Foot	02225-00010	4
14	Case, Bottom	02225-40027	1
15	Main Logic PCA	02225-60072	1
16	Screw, PCA Mounting	2200-0216	2
17	Backpanel	02225-60028	1
18	Switch Assy, On-Off	02225-60090	1
19	Keypad Switch Assy	02225-60904	1
20	Screw, Keypad	0624-0620	2
21	Switch Overlay	02225-80007	1
22	Screw, Top Cover	0624-0616	4
	Print Structure Assy	02225-60902	N/A

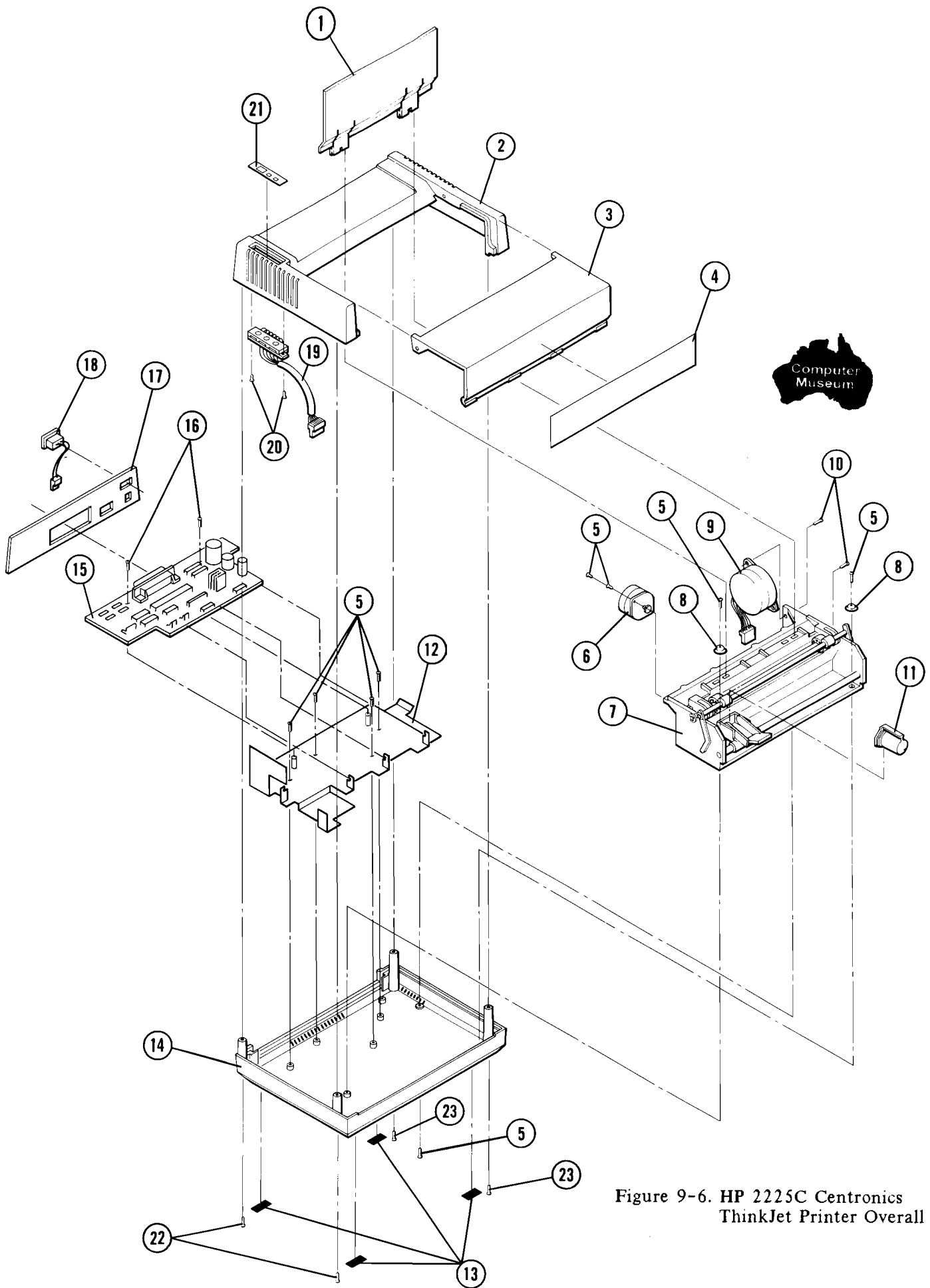

Figure 9-6. HP 2225C Centronics ThinkJet Printer Overall View

# HP 2225C PCA

Table 9-7. 02225-60072

Figure Reference	Part Description	Part Number	Qty
C1,9,26,27	CAP 0.1uF 20%	0160-4557	4
C2	CAP 6800uF 35V	0180-3365	1
C3,5,6,17-22,25	CAP .01uF 50V 20%	0160-4554	10
C4,7	CAP 1000pF	0160-4574	2
C8	CAP 100uF 50V AL	0180-3512	1
C10	CAP 680mF 35V	0180-3856	1
C11	CAP .1uF 5% 50V	0160-5471	1
C12	CAP 33uF	0180-2951	1
C13	CAP .047uF 10%	0160-4834	1
C14	CAP 10uF 50V	0180-2881	1
C15	CAP 33pF 5% 100V	0160-4807	1
C16	CAP 10pF 5% 100V	0160-4791	1
C23,24	CAP 470pF	0160-4808	2
CR1-4	DIO Pwr Rect 400V	1901-0848	4
CR5	DIO 1N4936	1901-1065	1
CR6,7	DIO 1N4150	1901-1098	2
F1	FUSE 3A	2110-0688	1
J2,6	CONN 2 Post Header	1251-6427	2
J3,4,7	CONN ML 6 Pin	1251-8089	3
J5	CONN Post TP Hdr	1251-7018	1
J8	CONN Flex Ckt 13	1251-8530	1
J9	CONN Centronics	1252-1784	1
L2	INDUCTOR 220uH	9140-1210	1
MP1	Heatsink	1205-0576	1
Q1	XSTR Switch IRF222 MOSFET	1855-0683	1
Q2,3	XSTR 2N4403 PNP	1853-0271	1
Q4,5	XSTR 2N3904 NPN	1854-0215	2
R1	RES 26.1K 1%	0698-3159	1
R2	RES 2.61K 1%	0698-0085	1
R3	RES 100K 1%	0757-0465	1
R4	RES 11K 1%	0757-0443	1
R5	RES 2.15K	0698-0084	1
R6	RES 121 1%	0757-0403	1
R7	RES 46.4K 1%	0698-3162	1
R8	RES 21.5K 1%	0757-0199	1
R9,37	RES 2.87K	0698-3151	2
R10	RES 42.2K	0698-3450	1

Table 9-7. 02225-60072 (Cont.)

Figure Reference	Part Description	Part Number	Qty
R11	RES 78.7K	0698-4508	1
R12	RES 137K	0698-4518	1
R13,29,30	RES 680 5% .25W	0683-6815	3
R14,22	RES 39K 5% .25W	0683-3935	2
R15	RES 8.25K .1%	0698-8061	1
R16	RES 10K .1%	0698-6360	1
R17	RES 1K 5% .25W	0683-1025	1
R18,20,28	RES 100K 5% .25W	0683-1045	3
R19	RES 1K	0757-0159	1
R21	RES 220 5% .25W	0683-2215	1
R23	RES 10M 5% .25W	0683-1065	1
R24,31	RES 1M 5% .25W	0683-1055	2
R25	RES 56K 5% .25W	0683-5635	1
R26	RES 4.7K 5% .25W	0683-4725	1
R27	RES 18K 5% .25W	0683-1835	1
R32,33	RES PK 10K x 9	1810-0277	2
R34,35	RES 100 5% .25W	0683-1015	2
R36	RES PK 100K x 9	1810-0281	1
S1	SWITCH Rocker 8-1A	3101-2243	1
U1	IC CPU	11J7-0016	1
U2	IC 1K RAM	1LK4-0001	1
U3	IC ROM	1LG7-0064	1
U4	IC 74HC373	1820-2998	1
U5	IC 74HC244	1820-3297	1
U6	IC MM74C374	1820-2216	1
U7	IC LM339	1826-0138	1
U8,9	XSTR ARY 7NPN	1858-0099	2
U10	IC ULN 2023A	1858-0097	1
U11	IC LM555	1826-0180	1
U13	IC MC1403	1826-0544	1
U14	IC SN74ALS1035	1820-3437	1
U15	IC MM74C00N	1820-2210	1
U16	IC 74C74	1820-1753	1
U17	IC 74HC14	1820-3185	1
VR1	DIO Zener 3.3V 5W	1902-1509	1
VR2	DIO Zener 33V .4W	1902-0970	1
VR3	IC LM2940		1
Y1	XTAL 3MHz	0410-1496	1

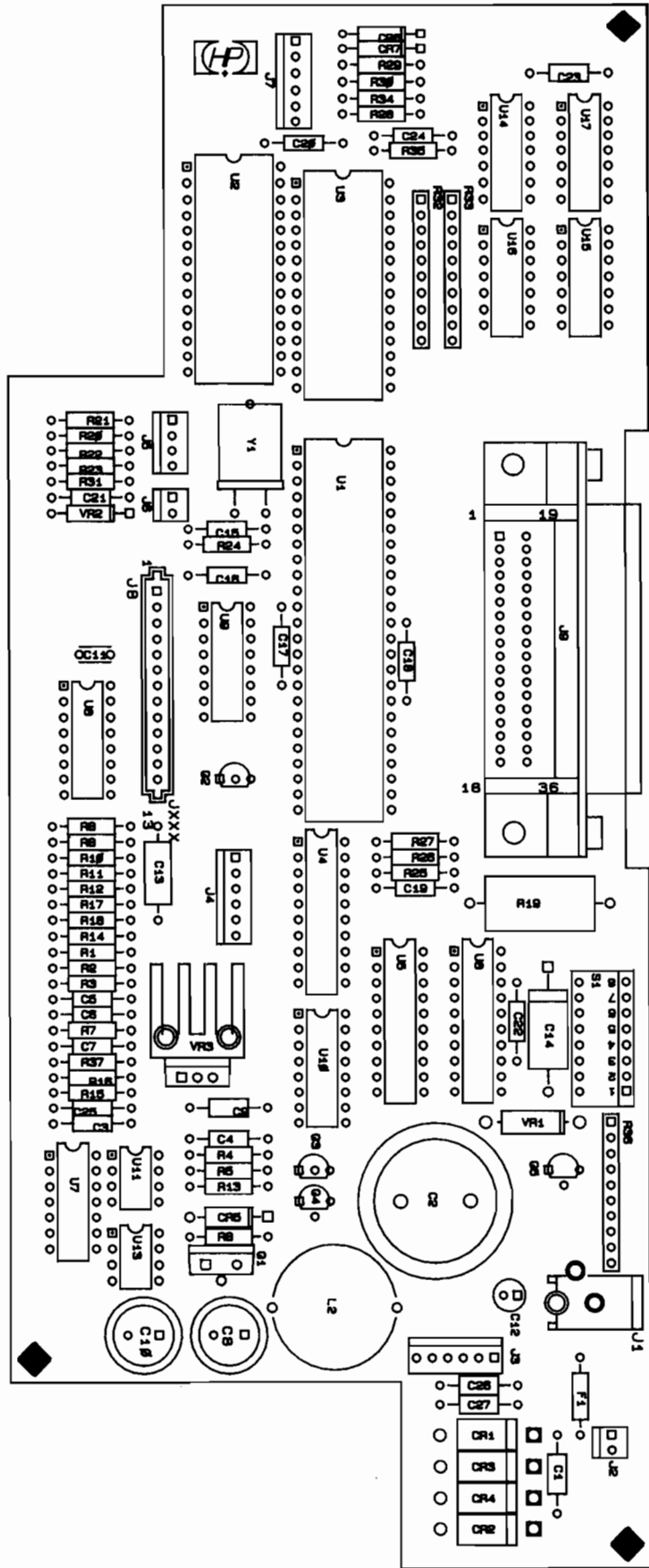

Figure 9-7. HP 2225C PCA Assembly Drawing

## HP 2225D Overall

Table 9-8. HP 2225D Overall Parts List

Figure Reference	Part Description	Part Number	Qty
1	Paper Separator (order front cover/window)	02225-40032	1
2	Case, Top	02225-40028	1
3	Front Cover/Window (order paper separator)	02225-40025	1
4	Label	02225-80097	1
5	Screw	0624-0621	8
6	Motor, Carriage	3140-0786	1
7	Mechanism Assembly	02225-60901	1
8	Mechanism Washer	02225-00017	2
9	Motor, Paper	3140-0788	1
10	Screw, Paper Motor	0515-1268	2
11	Print Cartridge (black)	92261A	1
12	Plate, Gnd	02225-00015	1
13	Foot	02225-00010	4
14	Case, Bottom	02225-40027	1
15	Main Logic PCA Model 2225D	02225-60069	1
	Model 2225DJ	02225-60074	1
16	Screw	2360-0495	6
17	Fuse	2110-0621	1
18	Screw	3030-0252	2
19	Washer		2
20	RS-232C I/O PCA	02225-60019	1
21	I/O Connector Standoff		2
22	Backpanel Assy	02225-60020	1
23	Fusebox, 100-120V	9135-0238	1
24	Switch, On-Off		1
25	Cable, I/O PCA	8120-4434	1
26	Nut		1
27	Transformer	9100-4384	1
28	Screws, Transformer Mounting	0624-0638	4
29	Keypad Switch Assy	02225-60904	1
30	Screw, Keypad	0624-0620	2
31	Keypad Overlay	02225-80007	1
32	Screw, Top Cover	0624-0616	4
	Print Structure Assy	02225-60902	N/A

Table 9-8. HP 2225D Overall Parts List (Cont.)

Figure Reference	Part Description	Part Number	Qty
	<b>Backpanel Fuses/Fuseholders</b> Fuse, 400mA Fuse, 250mA Fuse, 200mA Fuse, 100mA Fuseholder, US Fuseholder, European	2110-0340 2110-0489 2110-0588 2110-0202 2110-0686 2110-0687	1 1 1 1 1 1

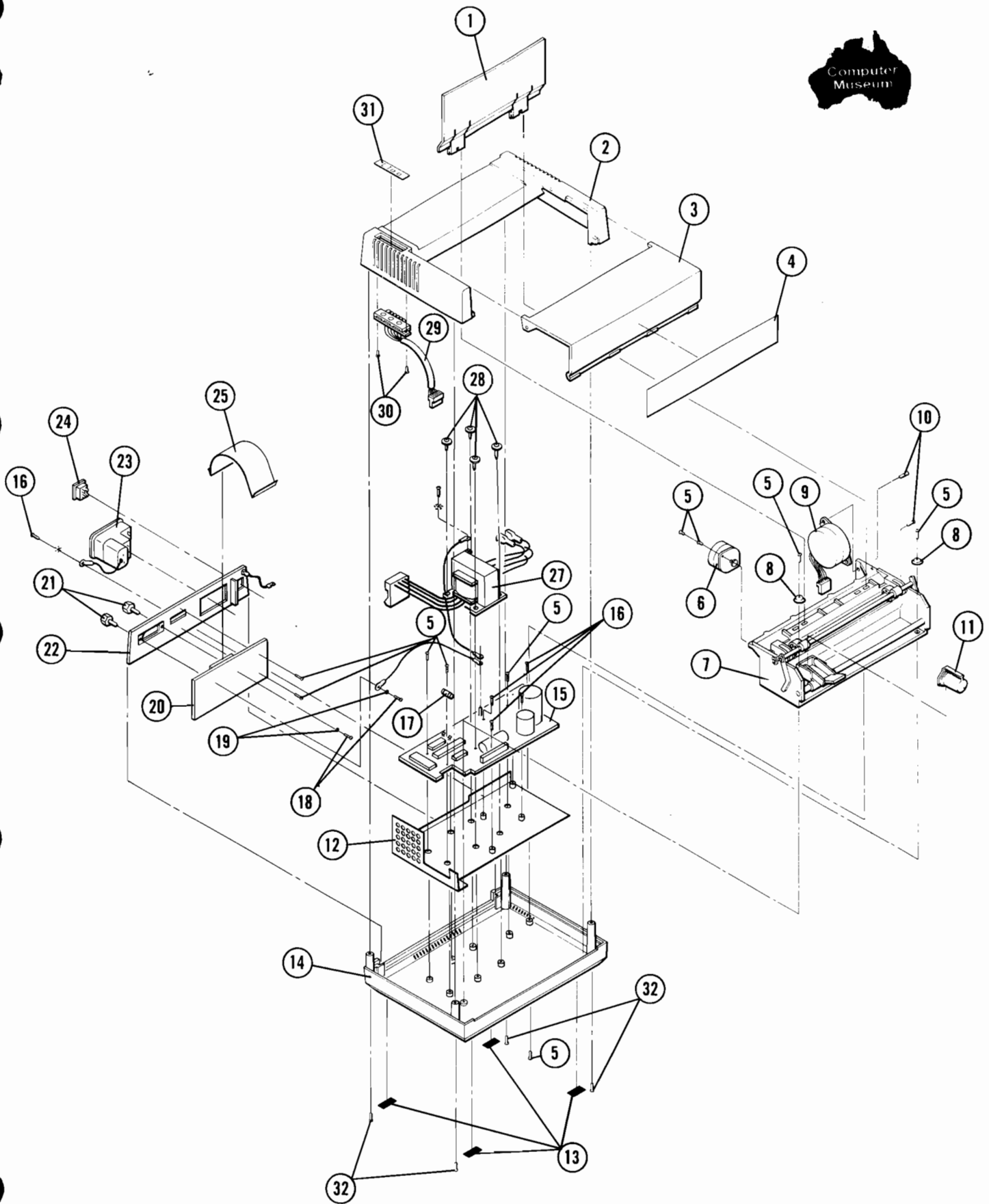

Figure 9-8. HP 2225D RS-232C ThinkJet Printer Overall View



# HP 2225D Main Logic PCA

Table 9-9. 02225-60069 & 60074

Figure Reference	Part Description	Part Number	Qty
C1	CAP 470uF 50V	0180-3451	1
C2	CAP 4700uF 16V	0180-3162	1
C6-9,16,33-35,40	CAP .01uF 20%	0160-4554	9
C10,11	CAP 33uF 16V 20%	0180-2951	2
C15,19,20	CAP 1uF 50V 20%	0180-3314	3
C17	CAP 33pF 5% 100V	0160-4807	1
C18	CAP 10pF 5% 100V	0160-4791	1
C37	CAP 680uF 35V	0180-3856	1
C38	CAP 330uF 35V 20%	0180-3450	1
CR1-4,7,16	DIO PWR 400V	1901-0731	6
CR9-13	DIO 1N4150	1901-1098	5
CR14,15	DIO 1N4934	1901-0693	2
F1	FUSE .5A 250V TD	2110-0621	1
J1	CONN 16P TD ENTR	1252-1615	1
J2	CONN Flex Ckt 13	1251-8530	1
J3,4,7	CONN ML 6 Pin	1251-8089	3
J5	CONN 4 Cont Post	1251-7018	1
J6	CONN 2 Cont Post	1251-6427	1
J8	CONN 4P MTA	1251-8958	1
MP1,2	HEAT SINK	1205-0576	2
MP4,5	FUSEHLDR Clip 10A	2110-0589	2
Q3	XSTR NPN 2N3904	1854-0215	1
R1	RES 237 Ohm 1%	0698-3442	1
R2	RES 4.22K 1%	0698-4645	1
R3,4	RES 1M 5% .25W	0683-1055	2
R5	RES 26.7K .1%	0698-6519	1
R6	RES 9.9K .1%	0698-6321	1
R7	RES 47 Ohm 5%	0683-4705	1
R10	RES 4.7K 5% .25W	0683-4725	1
R11	RES 10K 1%	0757-0442	1
R12	RES 10K 5% .25W	0683-1035	1
R14	RES 261K 1%	0698-3455	1
R15	RES 130K 1%	0757-0468	1
R16	RES 64.9K 1%	0698-4502	1
R21	RES 1.5K 5% .25W	0683-1525	1
R22	RES 39K 5% .25W	0683-3935	1

Table 9-9. 02225-60069 &amp; 60074 (Cont.)

Figure Reference	Part Description	Part Number	Qty
R23,24	RES 680 Ohm 5%	0683-6815	2
R25	RES 100K 5%	0683-1045	1
R26	RES 1.5K 5% .25W	0683-1525	1
R27	RES 10M 5% .25W	0683-1065	1
R30	RES 619 Ohm 1% 1/8W	0757-0418	1
R32	RES 18K 5%	0683-1835	1
R33	RES 56K 5%	0698-8356	1
U1	IC CPU	1LJ7-0014	1
U2	IC 1K RAM	1LK4-0001	1
U3	IC ROM		
	2225D	1LG7-0064	1
	2225DJ	1LG7-0080	1
U4	IC 74HC373	1820-2998	1
U7	IC 393	1826-0412	1
U8,9	XSTR ARRAY 7NPN	1858-0099	2
U10	IC ULN 2023A	1858-0097	1
VR1	IC LM317T	1826-0393	1
VR3	VOLT REG 7805	1826-0122	1
VR6	DIO ZNR 6.8V 5%	1902-0954	1
VR7	IC LM385BZ	1826-1360	1
VR8	DIO ZNR 33V 5%	1902-0970	1
VR9,15	DIO ZNR 45.3V 5%	1902-0038	2
VR13	IC MC7824CT	1826-1218	1
VR14	DIO ZNR 27V 5%	1902-0968	1
VR20	1N4752A	1902-0654	1
VR21	DIO ZNR 40.5V	1902-1503	1
W1,2,4,8,9,10,11	RES Zero Ohms	8159-0005	7
Y1	XTAL 3MHz	0410-1496	1

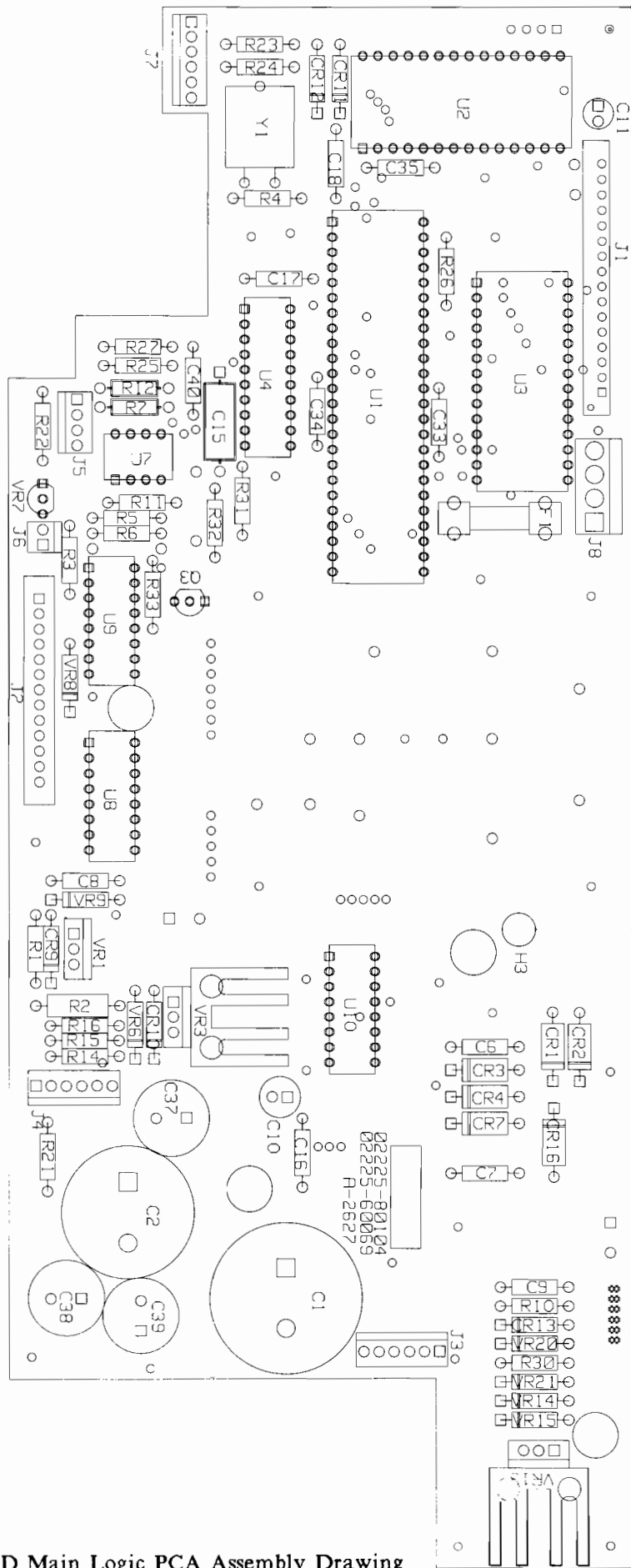

Figure 9-9. HP 2225D Main Logic PCA Assembly Drawing

**HP 2225D I/O  
PCA**

Table 9-10. 02225-60019

Figure Reference	Part Description	Part Number	Qty
C1,2	CAP 22pF 5%	0160-4787	2
C3,4	CAP 330pF 5%	0160-4810	2
C5-7,9,10	CAP .01uF 20%	0160-4554	5
C8	CAP .1uF 10% 50V	0160-4835	1
C11	CAP 1000pF 5%	0160-4822	1
J1	CONN DB25S	1252-0603	1
J2	CONN 16P Rt Angle	1251-8841	1
R1,2	RES NET 10K 2%	1810-0280	2
S1	SWITCH 8 POS SPST	3101-2726	1
S2	SWITCH 5 POS SPST	3101-2804	1
U1	IC MCU	1820-3936	1
U2	IC 6551	1820-2577	1
U3	IC 80C96	1820-3545	1
U5	IC MM74C00N	1820-2210	1
U6,7	IC MC14076BCP	1820-2220	2
U8	IC MC1489AL	1820-0990	1
U9	IC MC1488L	1820-0509	1
VR1	DIO ZNR 14.5V 5W	1902-0976	1
Y1	XSTAL 6MHz	0410-1414	1
Y2	XSTAL 1.84MHz	0410-1485	1

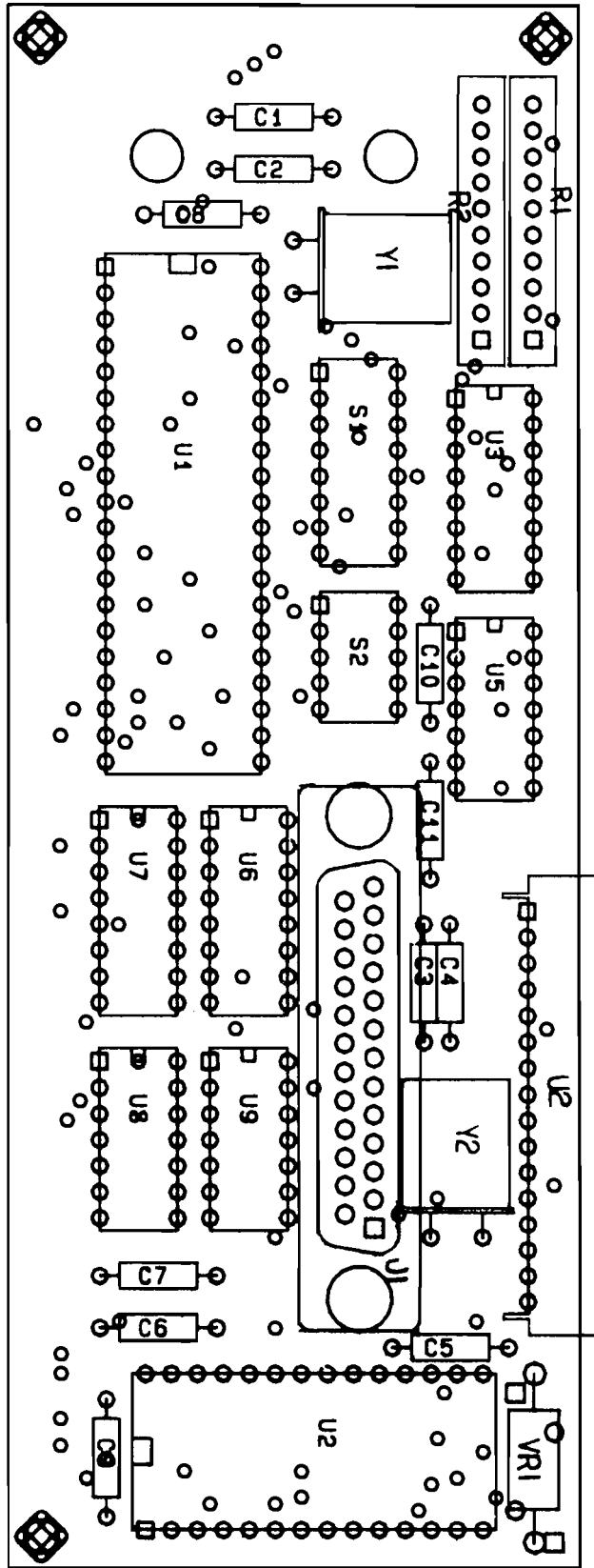

Figure 9-10. HP 2225D I/O PCA Assembly Drawing

## HP 2225P Overall

Table 9-11. HP 2225P Overall Parts List

Figure Reference	Part Description	Part Number	Qty
1	Paper Separator (order front cover/window)	02225-40032	1
2	Case, Top	02225-40028	1
3	Front Cover/Window (order paper separator)	02225-40025	1
4	Nameplate Label	02225-80097	1
5	Screw, 4-20	0624-0621	
6	Motor, Carriage	3140-0785	1
7	Mechanism Assy	02225-60901	1
8	Mechanism Washer	02225-0017	2
9	Motor, Paper	3140-0787	1
10	Screw, Paper Motor	0515-1268	2
11	Print Cartridge	92261A	1
12	Plate, Gnd	02225-00020	1
13	Foot	02225-00010	4
14	Case, Bottom	02225-40027	1
15	Main Logic PCA	02225-60061	1
16	Screw, 4-40	2200-0216	
17	Stand Off	02225-40039	2
18	Lock Washer, Gnd Cable	2190-0469	2
19	I/O Grounding Cable	1400-1402	1
20	Screw	3030-0189	1
21	Centronics I/O PCA	02225-60078	1
22	I/O Connector Standoff	1252-0699	2
23	Backpanel Assy which includes:	02225-60027	1
24	Power Switch	3101-2729	1
25	Cable, I/O PCA	02225-80109	1
26	Screw, 6-19	0624-0617	
27	Keypad Switch Assy	02225-60904	1
28	Screw, 4-20	0624-0620	2
29	Battery Pack	02225-60091	1
30	Switch Overlay	02225-80007	1
31	Screw, Top Cover	0624-0616	4
	Print Structure Assy	02225-60902	N/A

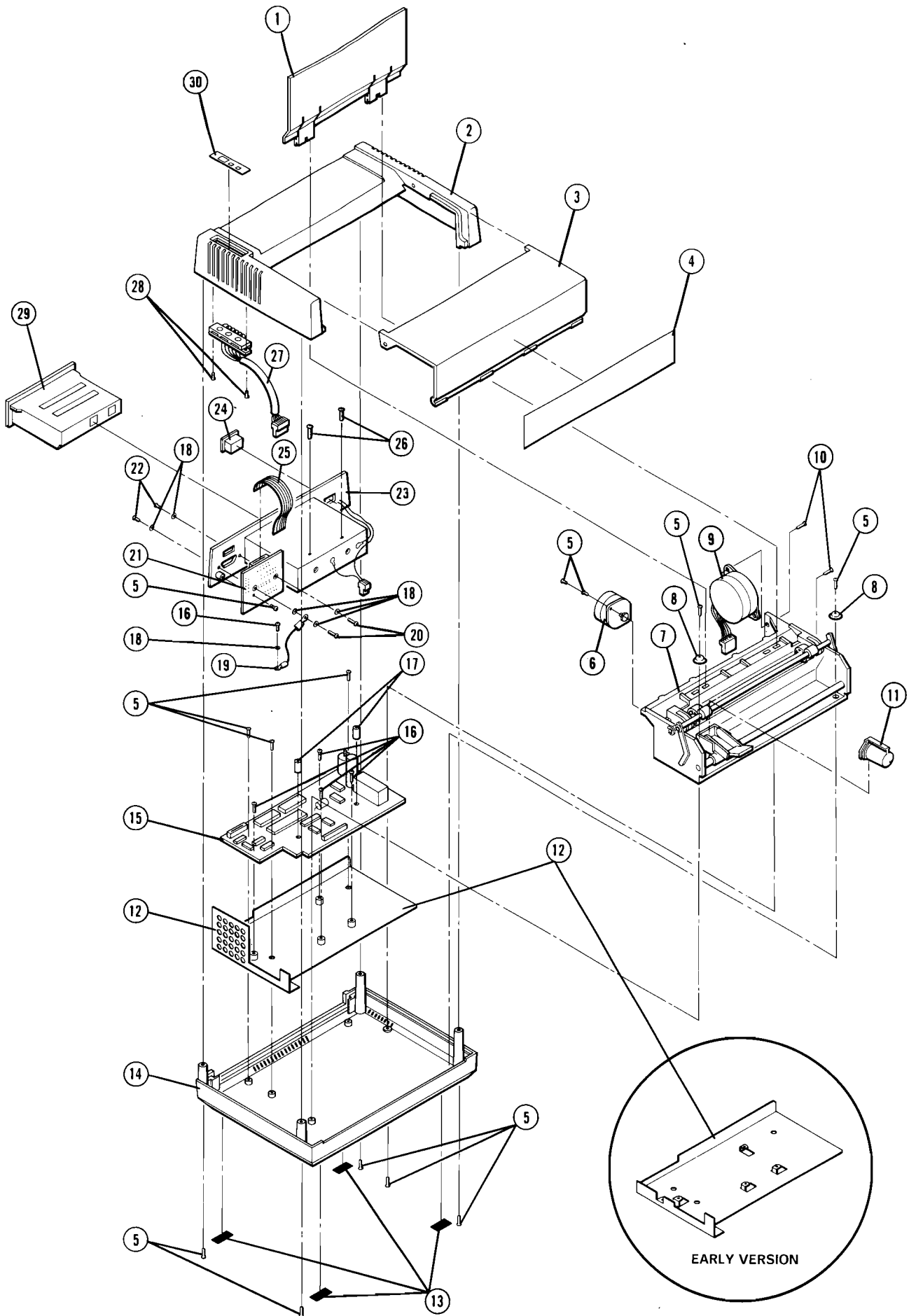

Figure 9-11. HP 2225P Battery Powered Centronics ThinkJet Printer  
Overall View

# HP 2225P Main Logic PCA

Table 9-12. 02225-60061

Figure Reference	Part Description	Part Number	Qty
C1	CAP 310pF 1%	0140-0226	1
C2,10,27,28,30,33,37	CAP .01uF 50V	0160-4554	9
C3	CAP 1500pF 5%	0160-4846	1
C4	CAP 330uF 35V	0180-3448	1
C5	CAP 100uF 10V AL	0180-3155	1
C6	CAP 0.047	0160-4834	1
C7	CAP .1uF 5% 50V	0160-5471	1
C8,34,35	CAP 1MF KM 50V	0180-3314	3
C9	CAP .1uF 20% 50V	0160-4835	1
C25	CAP 33pF 5% 100V	0160-4807	1
C26	CAP 10pF 5% 100V	0160-4591	1
C36	CAP 33uF 16V AL	0180-2951	1
C31	CAP 33uF 16V	0180-3449	1
CR2	DIODE-PWR RECT	1901-0789	1
CR3-10	DZ 1N4934	1901-0693	8
CR11,12	SW DIODE	1901-1098	2
J1	CONN 18P S	TPN-50649	1
J2	CONN FLX CKT 13	1251-8530	1
J3,4,7	CONN-LK-ML 6P	1251-8089	3
J5	CONN-POST-TP-HDR	1251-7018	1
J6,8	CONN-OPS MA	1251-6427	2
L1	INDUCTOR	9140-0843	1
Q3,15,17	XSTR NPN 2N3904	1854-0215	3
Q4,16	2N4403	1853-0271	2
Q5	XSTR NPN SJE1941	1854-0456	1
Q7-14	XSTR-TIP32 PNP	1853-0537	8
R1,61	RES 12K 5% .25W	0683-1235	2
R2,17,64,65	RES 100K 1%	0757-0465	4
R41,42,43,44	RES 60.0 1% .25W	0757-1042	4
R3,10	RES 2.87K 1%	0698-3151	2
R4	RES 90.9K	0757-0464	1
R5	RES 38.3K 1%	0698-3161	1
R6,16	RES 10K 5% .25W	0683-1035	2
R7,72	RES 470 5% .25W	0683-4715	2
R8	RES 30.1K 1%	0757-0453	1
R9	RES 46.4K 1% 1/8W	0698-3162	1
R11	RES 1K 5% .25W	0683-1025	1



Table 9-12. 02225-60061 Parts List (Cont.)

Figure Reference	Part Description	Part Number	Qty
R12	RES 6.81K	0757-0439	1
R13	RES 38.3 1%	0698-3435	1
R14,57	RES 137K 1%	0698-4518	2
R15	RES 1.05K 1%	0698-4467	1
R18	RES 3.57K 1%	0698-3496	1
R18,63	RES 4.32K 1%	0757-0436	2
R19	RES 26.7K 1%	0698-6519	1
R20	RES 9.9K 1%	0698-6321	1
R21,33	RES 100K 5% .25W	0683-1045	2
R22,24,66	RES 20K 1% .25W	0757-0449	3
R23	RES 47 5% .25W	0686-4705	1
R30,34	RES 820 5% .25W	0683-8215	2
R35	RES 220 5% .25W	0683-2215	1
R36	RES 39K 5% .25W	0683-3935	1
R37,38,39,40	RES 46.4 1% .52W	0698-3398	1
R45	Network-RES SIP	1810-0275	1
R48	RES 10M 5% .25W	0683-1065	1
R55	RES 42.2K 1% 1/8W	0698-3450	1
R56	RES 78.7K	0698-4508	1
R59,60	RES 1M 5% .25W	0683-1055	2
R62	RES 680 5%	0683-6815	1
R69	RES 4.7K	0683-4725	1
R70	RES 18K	0683-1835	1
R71	RES 56K	0698-8356	1
	Heat Shrink	0890-1515	1
U1	IC 555	1826-0180	1
U3	IC 339	1826-0138	1
U4	LM330T	1826-0904	1
U5	LM393	1826-0412	1
U6	CPU	1LJ7-0014	1
U7	RAM 8K	1LK4-0001	1
U8,9,10	XSTR ARRAY	1858-0099	3
U11	ROM P VESU	1LG7-0064	1
U12	IC 74HC10	1820-2923	1
U13	IC 74HC132	1820-3174	1
U14	IC 74C74	1820-1753	1
U15	IC 74LS1035	1820-3437	1
U16	IC 74HC373	1820-2998	1
U17	IC 74C00	1820-2210	1
VR10	LM3858XZ	1826-1360	1
VR12,13	DIODE ZNR 16V 5%	1902-0783	2
VR5,6	DIO ZNR 33V .4W	1902-0970	2
Y1	XTAL-3MHz	0410-1496	1

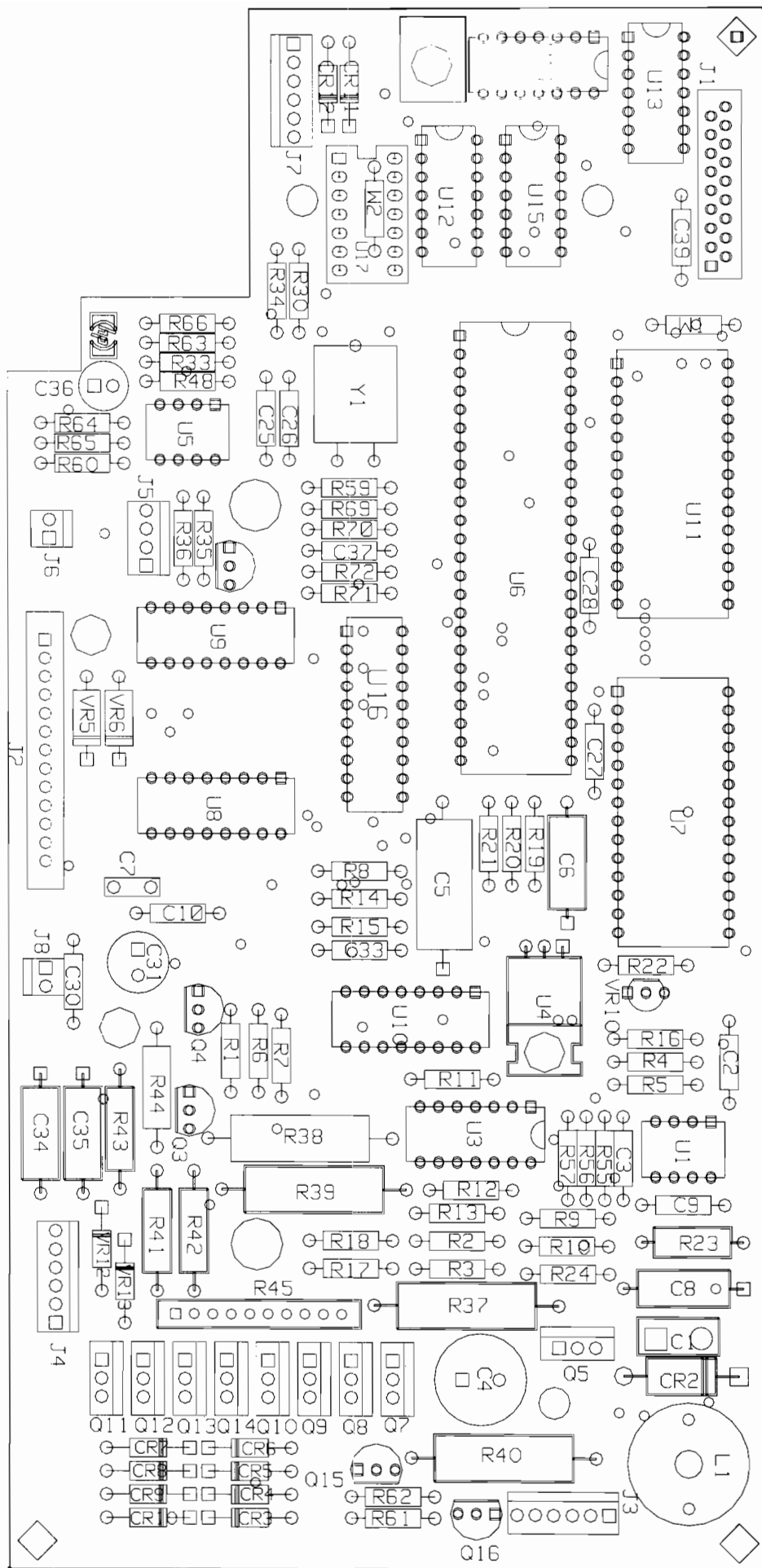

Figure 9-12. HP 2225P Main Logic PCA Assembly Drawing

**HP 2225P I/O  
PCA**

Table 9-13. 02225-60078 Parts List

<b>Figure Reference</b>	<b>Part Description</b>	<b>Part Number</b>	<b>Qty</b>
C1,2,3	CAP 0.01uF 50V	0160-4554	3
C4,5	CAP 470pF	0160-4808	2
J1	CONN 15P	1252-1964	1
J2	CONN 18PR	1252-1967	1
R1,2	NETWORK RES 3.3K x 9	1810-0278	2
R3	RES PK 3.3K x 5	Replace PCA	1
R4,5	RES 100 Ohm	0683-1015	2
S1	SWITCH 8 POS SPST	3101-2726	1
U1	IC 74C374	1820-2216	1
U2	IC 74C240	1820-2566	1

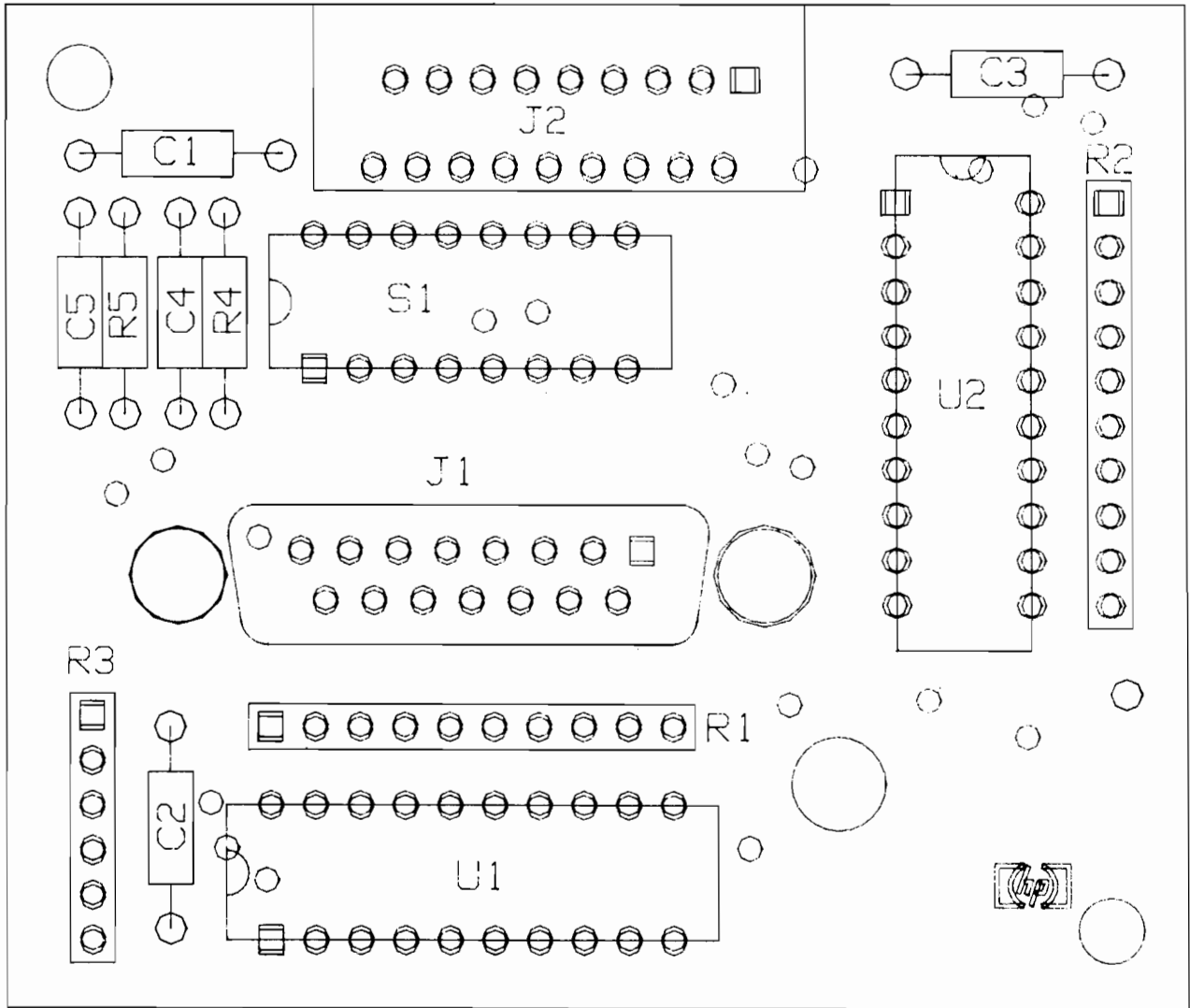

Figure 9-13. HP 2225P I/O PCA Assembly Drawing

## Mechanism

Table 9-14. HP ThinkJet Mechanism Parts List

Figure Reference	Part Description	Part Number	Qty
1	Retainer, E-Ring	0510-0952	2
2	Arm, Left Bail (early version only)	02225-00005	1
3	Screw (early version only)	0515-1068	1
4	Shaft, Carriage	02225-20006	1
5	Spring, Left Side	02225-20011	1
6	Retainer, E-Ring	0510-0083	4
7	Bearing, Sleeve	1410-0251	2
8	Screw, 2-28x.250	0624-0614	2
9	Support, Absorber	02225-00012	1
10	Wheel, Tractor Pin	02225-40010	2
11	Wheel, Grit	02225-40030	2
12	Guide	02225-40009	2
13	Frame, Platen	02225-40018	1
14	Home Switch Assy	5061-4313	1
15	Screw/washer, Switch	0624-0623	1
16	Shaft, Platen	02225-20009	1
17	Motor, Paper		
	2225A/C/D	3140-0788	1
	2225B/2225P	3140-0787	1
18	Screw, 4-20x.375	0624-0621	2
19	Motor, Carriage		
	2225A/C/D	3140-0786	1
	2225B/P	3140-0785	1
20	Switch, Reed	0490-1424	1
21	Screw w/washer, SEM 2-28.x.250	0624-0611	2
22	Screw, 6-19x.50	0624-0634	1
23	Washer, Star (2225A/D)	2190-0065	1
24	Wire, Grounding (2225A/D)	02225-80036	1
25	Shield, Magnetic	02225-00016	1
26	Wire, Grounding (2225A/D)	02225-80037	1
27	Washer, Star (2225A/D)	2190-0009	1
28	Screw, 4x.7x10mm	0515-1268	2
29	Retainer, E-Ring	0510-0015	2
30	Gear, Idler	02225-40022	1
31	Gear, Cluster	02225-40021	1
32	Gear, Output P.D.	02225-40023	1
33	Dowel	02225-20017	1
34	Spring, Right Side	02225-20008	1
35	Retainer, E-Ring	0510-0045	6
36	Arm, Bail	02225-00004	2
37	Dowel, Bail Shaft	02225-20018	2

Table 9-14. HP ThinkJet Mechanism Parts List (Cont.)

Figure Reference	Part Description	Part Number	Qty
38	Roller, Pinch	02225-20001	2
39	Carriage Assy	02225-60903	1
40	Clip, Flex Circuit	02225-40005	1
41	Shaft, Bail		
	Early Version	02225-20007	1
	Later Version	02225-20023	1
42	Print Structure Assy	02225-60902	1

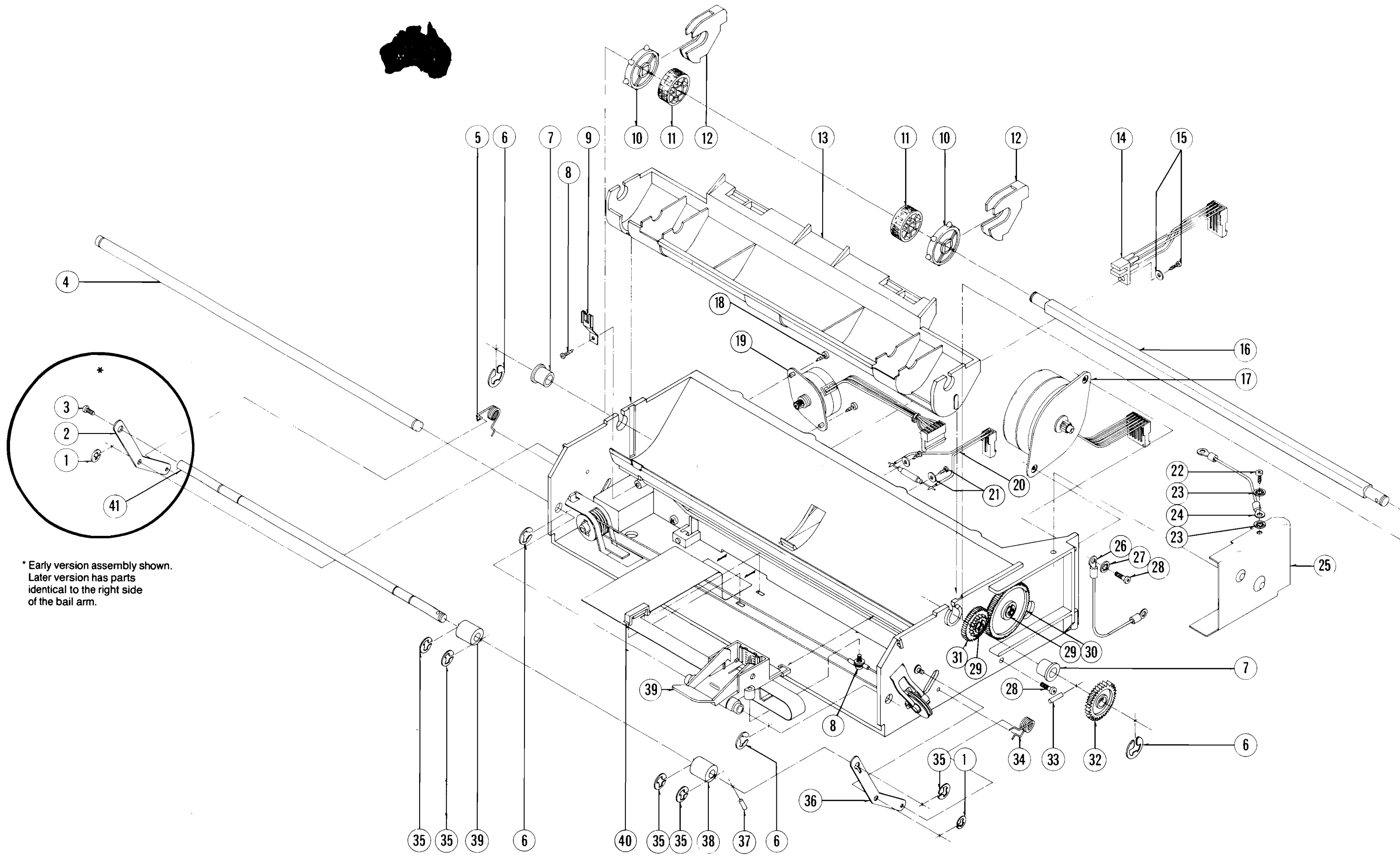

\* Early version assembly shown.  
Later version has parts  
identical to the right side  
of the bail arm.

Figure 9-14. HP ThinkJet Mechanism

## Documentation Summary

Table 10-1. HP ThinkJet Printer Documentation

Part Number	Manual Description
02225-90031	HP 2225A Owner's Manual
02225-90032	HP 2225B Owner's Manual
02225-90077	HP 2225C Owner's Manual
02225-90034	HP 2225D Owner's Manual
02225-90073	HP 2225P Owner's Manual
02225-90079	HP ThinkJet Printer Service Manual

## IBM/Epson Control Codes

Table 10-2. Compatible IBM/Epson Control Sequences

Print Feature	Esc Sequence Ctl Code	ASCII Decimal Equivalent	ASCII Hex Equivalent
<b>Print Pitch</b>			
Expanded On	ctl N	14	0E
Expanded Off	ctl T	20	14
Compressed On	ctl O	15	0F
Compressed Off	ctl R	18	12
Exp-Comp On	ctl N ctl O	14,15	0E,0F
Exp-Comp Off	ctl T ctl R	20,18	14,12



Table 10-2. Compatible IBM/Epson Control Sequences (Cont.)

Print Feature	Esc Sequence Ctl Code	ASCII Decimal Equivalent	ASCII Hex Equivalent
<b>Bold Mode</b>			
Bold Mode On	esc E	27,69	1B,45
Bold Mode Off	esc F	27,70	1B,46
<b>Underline</b>			
Underline On	esc -1	27,45,49	1B,2D,31
Underline Off	esc -0	27,45,48	1B,2D,30
<b>Line Spacing</b>			
6 lpi	esc 2	27,50	1B,32
8 lpi	esc 0	27,48	1B,30
7 dot row	esc 1	27,49	1B,31
# dot row	esc A CHR\$(#)	27,65,#	1B,41,(# Hex)
<b>Perf Skip</b>			
Perf Skip On	esc N CHR\$(#)	27,78,#	1B,4E,(# Hex)
Perf Skip Off	esc O	27,79	1B,4F
<b>Page Length</b>			
# Lines/Page	esc C CHR\$(#)	27,67,#	1B,43,(# Hex)
# Inches/Page	esc C CHR\$(0) CHR\$(#)	27,67,0,#	1B,43,0,(# Hex)
<b>Unidirectional or Bidirectional Print</b>			
Unidirectional	esc U1	27,85,49	1B,55,31
Bidirectional	esc U0	27,85,48	1B,55,30
<b>Print Position Controls</b>			
Line Feed	ctl J	10 or 138	0A or 8A
Carriage Return	ctl M	13 or 141	0D or 8D
Back Space	ctl H	8 or 136	08 or 88
Form Feed	ctl L	12 or 140	0C or 8C
<b>Graphics</b>			
Low Density Column	esc K#1#2	27,75,#1,#2	1B,4B,(#1 Hex), (#2 Hex)
High Density Column	esc L#1#2	27,76,#1,#2	1B,4C,(#1 Hex), (#2 Hex)
<b>Reset</b>			
Perform Reset	esc @	27,64	1B,40

# HP PCL Control Codes

Table 10-3. Compatible HP PCL Control Codes

Print Feature	Esc Sequence or Ctl Code	ASCII Decimal Equivalent	ASCII Hex Equivalent
<b>Print Pitch</b>			
Normal	esc &k0S	27,38,107,48,83	1B,26,6B,30,53
Expanded	esc &k1S	27,38,107,49,83	1B,26,6B,31,53
Compressed	esc &k2S	27,38,107,50,83	1B,26,6B,32,53
Exp-Comp	esc &k3S	27,38,107,51,83	1B,26,6B,33,53
<b>Bold Mode</b>			
Bold mode on	esc (s1B	27,40,115,49,66	1B,28,73,31,42
Bold mode off	esc (s0B	27,40,115,48,66	1B,28,73,30,42
<b>Underline</b>			
Underline on	esc &dD	27,38,100,68	1B,26,64,44
Underline off	esc &d@	27,38,100,64	1B,26,64,40
<b>Line Spacing</b>			
6 lpi	esc &l6D	27,38,108,54,68	1B,26,6C,36,44
8 lpi	esc &l8D	27,38,108,56,68	1B,26,6C,38,44
<b>Perf Skip</b>			
Perf Skip on	esc &l1L	27,38,108,49,76	1B,26,6C,31,4C
Perf Skip off	esc &l0L	27,38,108,48,76	1B,26,6C,30,4C
<b>Page Length</b>			
# lines/page	esc &l#P	27,38,108,#,..#,80	1B,26,6C,#,..#,50
<b>Text Length</b>			
# lines/text area	esc &l#F	27,38,108,#,..#,70	1B,26,6C,#,..#,46
<b>End of Line</b>			
<b>Wrap-around</b>			
Wrap-around on	esc &s0C	27,38,115,48,67	1B,26,73,30,43
Wrap-around off	esc &s1C	27,38,115,49,67	1B,26,73,31,43
<b>Display Functions</b>			
<b>Mode</b>			
Display Functions on	esc Y	27,89	1B,59
Display Functions off	esc Z	27,90	1B,60

Table 10-3. Compatible HP PCL Control Codes (Cont.)

Print Feature	Esc Sequence or Ctl Code	ASCII Decimal Equivalent	ASCII Hex Equivalent
<b>Unidirectional or Bidirectional Print</b>			
Unidirectional Print	esc &k0W	27,38,107,48,87	1B,26,6B,30,57
Bidirectional Print	esc &k1W	27,38,107,49,87	1B,26,6B,31,57
<b>Print Position Controls</b>			
Line Feed	ctl J	10	0A
Carriage Return	ctl M	13	0D
Back Space	ctl H	8	08
Half Line Feed	esc =	27,61	1B,3D
Form Feed	ctl L	12	0C
<b>Graphics</b>			
Low Density	esc *r640S	27,42,114,54,52, 48,83	1B,2A,72,36,34, 30,53
High Density	esc *r1280S	27,42,114,49,50,56, 48,83	1B,2A,72,36,34, 30,53
Raster Dot Row	esc *b#W	27,42,98,#,..#,87	1B,2A,62,#,..#,57
Begin Raster	esc *rA	27,42,114,65	1B,2A,72,41
End Raster	esc *rB	27,42,114,66	1B,2A,72,42

---

## Notes

## Introduction

Chapter 11 is intended to adapt service manual information to earlier version ThinkJet printers. This is the third revision to the HP ThinkJet Printer Service Manual. Two major product line changes occurred since the preceding ThinkJet Service Manual:

- A new version HP 2225C Centronics ThinkJet printer. This version (identified by a "+" on the 2225C bottom label or backpanel) replaces two 2225C printers. For information on the preceding HP 2225C ThinkJet printers, see "Earlier Version 2225C Printers" in this chapter.
- Addition of the HP 2225P Battery Centronics ThinkJet printer.

Information is arranged as follows:

- Bail Arm Adjustment
- Earlier Version 2225C Printers

## Bail Arm Adjustment

The following bail arm adjustment is performed on early version ThinkJet printer mechanisms only. If you do not have an early version mechanism, no bail arm adjustment is necessary. To determine if you have an early version mechanism, remove the top cover (See Chapter 6 for removal procedure) and look at the left side of your bail arm assembly. If the bail is connected to the left bail arm with a screw, the bail arm adjustment applies. Disregard the bail arm adjustment procedure if your ThinkJet printer bail is attached to the left bail arm with a retaining ring. See Figure 11-1.

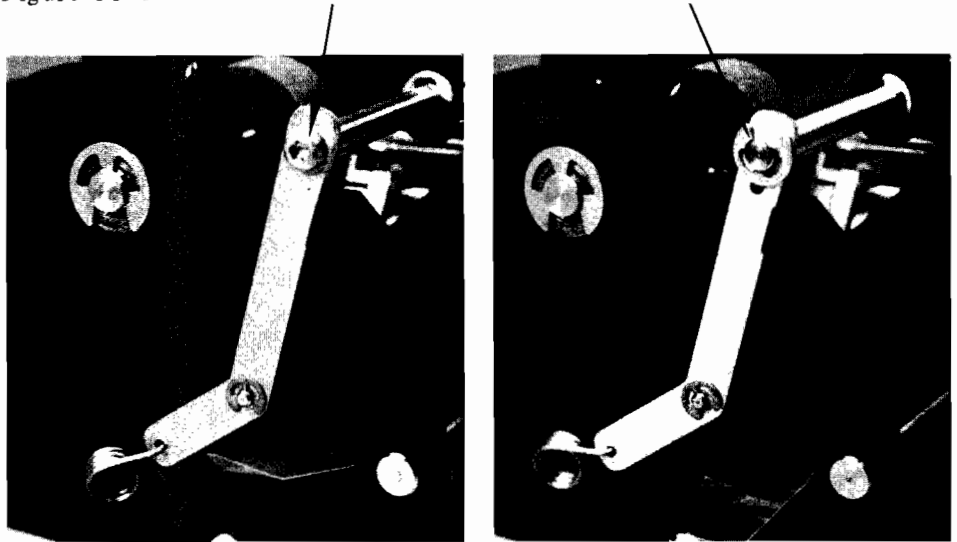

Figure 11-1. Bail Assembly Identification

The bail arm must be adjusted correctly to allow the pinch rollers to apply pressure evenly to the paper. If the pressures are uneven, the paper will skew as it moves through the mechanism. If necessary, refer to Removal and Replacement in this section for bail arm assembly and disassembly procedures.

1. Apply downward pressure on the left side of the bail arm assembly while lifting the right side of the bail, as shown in Figure 11-2. The right pinch roller should lift a short distance (approximately 1/8 to 1/4 inch) off the grit wheel before meeting heavy resistance.
  - A. If there is no "play" in the right side, apply more outward pressure until the right side of the shaft loosens up.
  - B. If there is too much play, i.e., the right bail arm easily goes backward and hits the stop on the print frame, the screw on the left of the bail shaft is too loose.

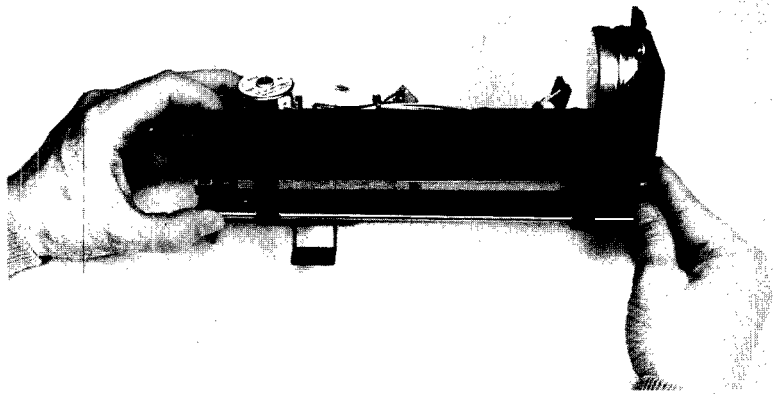

Figure 11-2. Bail Arm Adjustment, Right Side

2. Once the right side is adjusted properly, apply downward pressure on the right side of the bail arm assembly and lift the left side of the bail, as shown in Figure 11-3. The left pinch roller should have the same amount of play. If not, use the same techniques outlined above to make the proper adjustment.

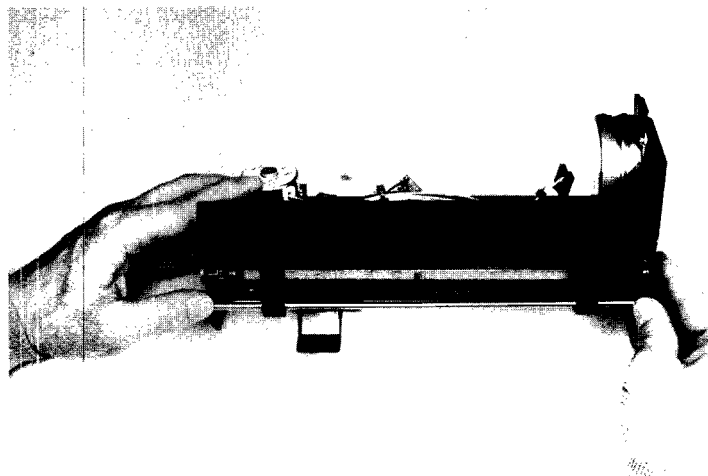

Figure 11-3. Bail Arm Adjustment, Left Side

3. Once both sides are set correctly, rotate the platen shaft either by hand or with the FF key and ensure that both pinch rollers are driven by the grit wheels.

## Earlier Version 2225C Printers

HP 2225C ThinkJet printers with a backpanel or bottom label model number of "2225C" (rather than "2225C+") are considered earlier version 2225C printers. These earlier 2225C Centronics ThinkJet printers consists of two versions:

- 2225C (US version)
- 2225C (International or Int version)

The 2225C (US) and 2225C (Int) version printers are distinguishable by the backpanel. The international version contains a fuse box with selectable voltage settings of 100, 120, 220, or 240 volts (see Figure 11-4). The U.S. version does not have a selectable input voltage. The backpanel contains a separate power cord plug and fuseholder and is designed to operate at 120 VAC 50/60Hz (see Figure 11-5).

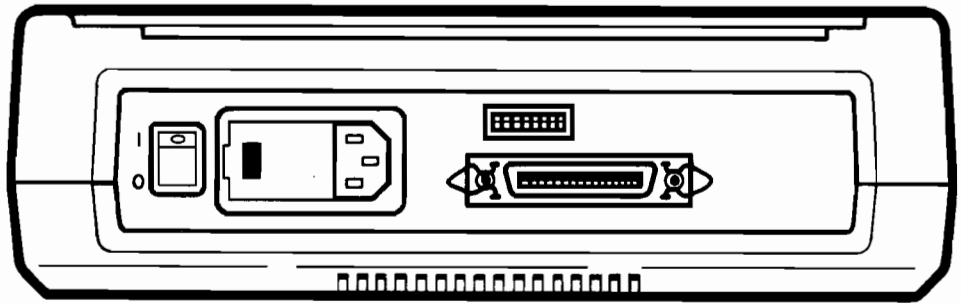

Figure 11-4. HP 2225C (Int) Version Backpanel

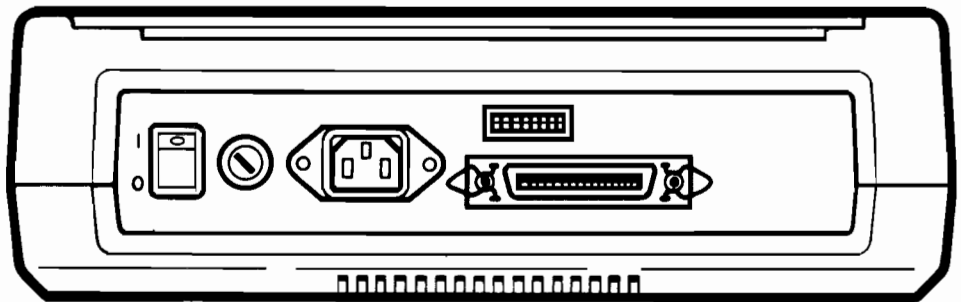

Figure 11-5. HP 2225C (US) Version Backpanel

2225C information in chapters 1 through 8 applies to the earlier version 2225C ThinkJet printers except that listed in this section.

## Specification Differences

<b>Weight</b> (US and Int versions)	6.8 lbs (3.1 kg)
<b>Power Requirements</b>	
2225C (US)	120VAC (+5%/-10%), 50/60Hz
2225C (Int)	Switch Selectable 100, 120, 220, 240VAC (+5%/-10%), 50/60Hz

## Fuses and Voltage

The 2225C (Int version) uses the same power module as the 2225A and 2225D ThinkJet printers. See Chapter 1, "HP 2225A & 2225D Fuses and Voltage", for 2225C (Int) version fuse and voltage information.

The HP 2225C with US backpanel must be operated from 120 volts AC, 50/60 Hz. Operating if from any other voltage may cause damage to your printer.

To replace the backpanel fuse on a 2225C (US version):

1. Push in the fuse holder cap with a wide blade screwdriver and turn it counterclockwise.
2. Place the fuse on the fuse holder and push the fuse holder into the cavity with a wide-blade screwdriver.
3. Replace the cap and turn it clockwise.

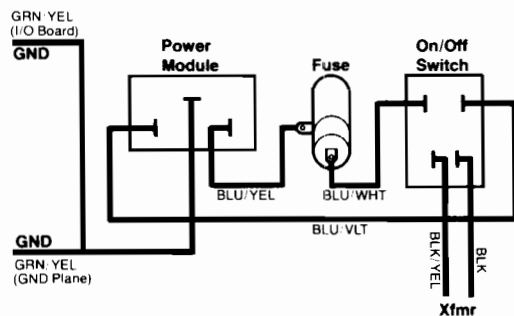

U.S. Rear Panel

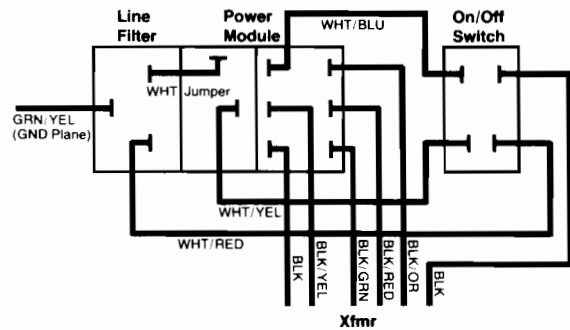

International Rear Panel



## **Functional Description**

The functional description for the 2225C (US) and 2225C (Int) differs from the 2225C explained in chapter 5 in the following sections:

- Power Supply
- Stepper Motor Drive
- Reset Circuitry

Follow 2225A & 2225D functional descriptions for the circuitry listed above.

## **PCA Removal Procedures**

Use "2225D Main Logic & I/O PCA removal procedures to remove the 2225C (US) and 2225C (Int) Main Logic and I/O PCAs.

## **Adjustments**

Use 2225A & 2225D power supply adjustment procedures to adjust VHD on the 2225C (US) and 2225C (Int) version ThinkJet printers.

## **Replaceable Parts**

Table 11-1 through 11-3 contain parts lists for earlier version HP 2225C ThinkJet printers. These parts lists refer to Figures 11-6 through 11-10 for part identification.

(Intentionally Left Blank)

Table 11-1. Earlier Version 2225C Overall Parts List

Fig 11-6 Reference	Part Description	Part Number	Qty
1	Paper Separator	02225-40032	1
2	Case, Top	02225-40028	1
3	Front Cover/Window	02225-40025	1
4	Window Label (US)	02225-80024	1
4	Window Label (Int)	02225-80059	1
5	Screw, 4-20	0624-0621	
6	Motor, Carriage	3140-0786	1
7	Service Mechanism Assy	02225-60901	1
8	Mechanism Washer	02225-0017	2
9	Motor, Paper	3140-0788	1
10	Screw, Paper Motor	0515-1268	2
11	Print Cartridge (black)	92261A	1
12	Plate, Gnd	02225-00015	1
13	Foot	02225-00010	4
14	Case, Bottom	02225-40027	1
15	Main Logic PCA		
	2225C	02225-60066	1
	2225CT	02225-60067	1
	2225CV	02225-60068	1
16	Screw	2360-0495	4
17	Fuse	2110-0621	1
18	Screw	3030-0252	2
20	Centronics I/O PCA	5061-4316	1
21	Connector Flange (included with PCA)		
22	Backpanel Assy (US), which includes:	02225-60015	1
23	Fuse, 400mA	2110-0340	1
24	Fuseholder Cap	2110-0565	1
25	Switch, On/Off	3101-2443	1
26	Backpanel Assy (Int), which includes:	02225-60014	1
27	Fusebox, 100-240V	9135-0238	1
28	Cable, I/O PCA	8120-4434	1
29	Screw, Transformer Mounting	0624-0638	4
30	Keypad Switch Assy	02225-60904	1
31	Screw, Keypad	0624-0638	2
32	Switch Overlay	02225-80007	1
33	Screw, Top Cover	0624-0616	4
34	Transformer	9100-4384	1
	Print Structure Assy	02225-60902	N/A
	International Version Fuses & Fuseholders		
	500mA	2110-0202	1
	400mA	2110-0340	1
	250mA	2110-0489	1
	200mA	2110-0588	1
	US Fuseholder	2110-0686	1
	European Fuseholder	2110-0687	1

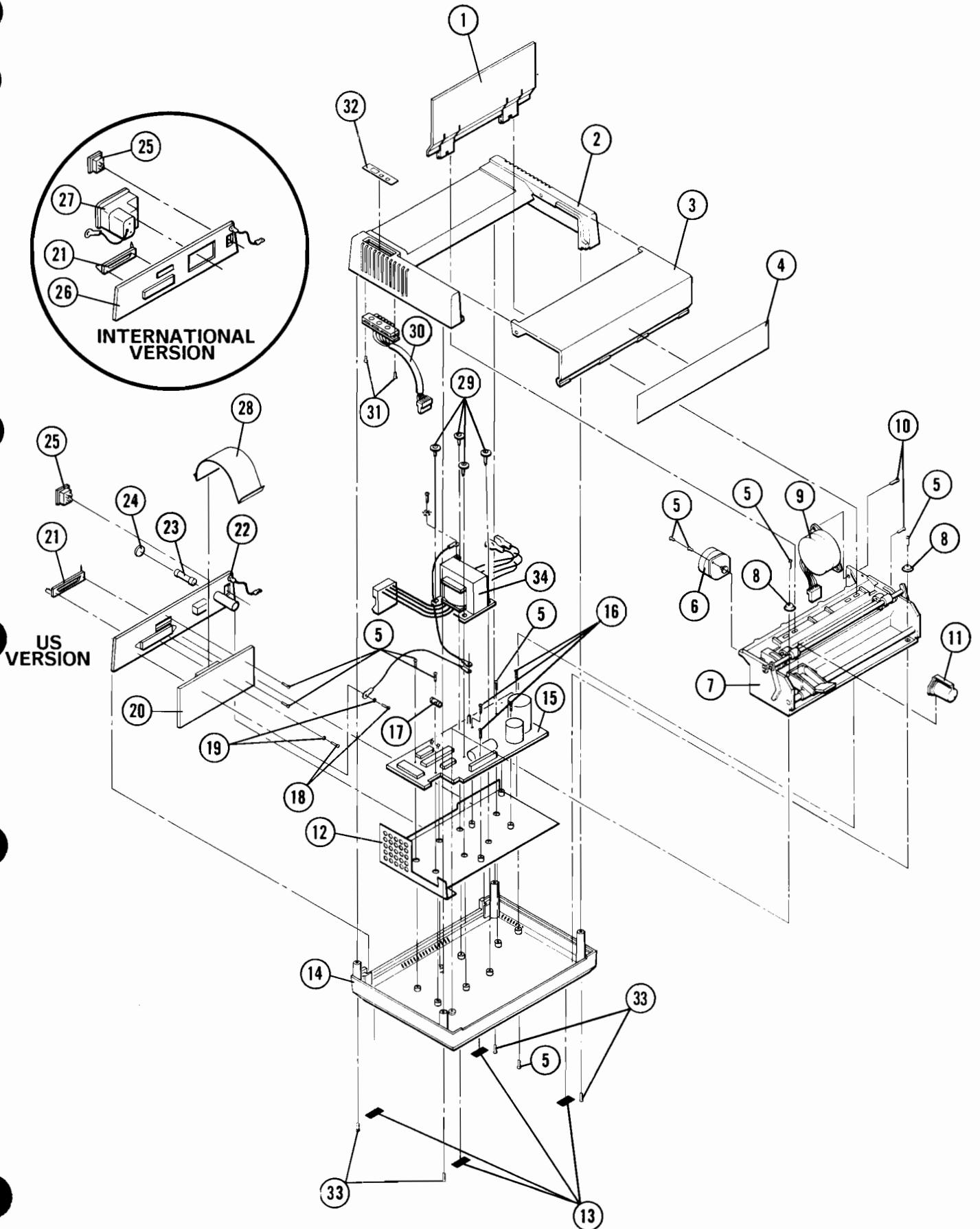

Figure 11-6. Earlier Version 2225C Exploded Diagram

Table 11-2. Earlier Version 2225C Main PCA Parts List

Fig 11-7 Reference	Part Description	Part Number	Qty
C1	CAP 470uF 50V	0180-3451	1
C2	CAP 4700uF 16V	0180-3162	1
C6-9,16,33-35,36	CAP .01uF 20%	0160-4554	9
C10,11	CAP 33uF 16V 20%	0180-2951	2
C14	CAP .047uF 10%	0160-4834	1
C17	CAP 33pF 5% 100V	0160-4807	1
C18	CAP 18pF 5% 100V	0160-4791	1
C19,20	CAP 1uF 50V 20%	0180-3314	2
C37	CAP 330uF 38V 100%	0180-3448	1
C38	CAP 330uF 35V 20%	0180-3450	1
CR1-8	DIO PWR 400V	1901-0731	8
CR9-13	DIO 1N4150	1901-1098	5
CR14,15	DIO 1N4934	1901-0693	2
F1	FUSE .5A 250V TD	2110-0621	1
J1	CONN 16P-TD ENTR	1251-8840	1
J2	CONN Flex Ckt 13	1251-8530	1
J3,4,7	CONN ML 6 Pin	1251-8089	3
J5	CONN 4 Cont Post	1251-7018	1
J6	CONN 2 Cont Post	1251-6427	1
J8	CONN 4P MTA	1251-8958	1
MP1,2	Heat Sink	1205-0576	2
MP4,5	FUSEHOLDER Clip 10A	2110-0589	2
Q1	XSTR NPN 2N3904	1854-0215	1
Q2	XSTR PNP 2N4403	1853-0271	1
R1	RES 237 Ohm 1%	0698-3442	1
R2	RES 4.22K 1%	0698-4645	1
R3,4	RES 1M 5% .25W	0683-1055	2
R5	RES 26.7K .1%	0698-6519	1
R6	RES 9.9K .1%	0698-6321	1
R8,22	RES 39K 5% .25W	0683-3935	2
R9,23,24	RES 680 Ohm 5%	0683-6815	3
R10	RES 4.7K 5% .25	0683-4725	1
R11	RES 10K 1%	0757-0442	1
R13	RES 100K 5%	0683-1045	1
R14	RES 261K 1%	0698-3455	1
R15	RES 130K 1%	0757-0468	1
R16	RES 64.9K 1%	0698-4502	1
R17	RES 1K .25W 5%	0683-1025	1
R21	RES 1.5K 5% .25W	0683-1525	1
R25,26	RES 100K 5%	0683-1045	2
R27	RES 10M 5% .25W	0683-1065	1
U1	CPU	1LJ7-0014	1

Table 11-2. Earlier Version 2225C Main PCA Parts List (Cont.)

Fig 11-7 Reference	Part Description	Part Number	Qty
U2	IC 1K RAM	1LK4-0001	1
U3	IC ROM		
	02225-60066	1LG7-0064	1
	02225-60067	1LG7-0079	1
	02225-60068	1LG7-0078	1
U4	IC 74HC373	1820-2998	1
U7	IC 393	1826-0412	1
U8,9	XSTR ARRAY 7NPN	1858-0099	2
U10	IC ULN 2023A	1858-0097	1
VR1	IC LM317T	1826-0393	1
VR1	IC MC7824CT	1826-1218	1
VR3	IC Volt Reg 7805	1826-0122	1
VR6	DIO Zener 6.8V 5%	1902-0954	1
VR7	IC LM385BZ	1826-0774	1
VR8	DIO Zener 33V 5%	1902-0970	1
VR9,15	DIO Zener 45.3V 5%	1902-0038	2
VR14	DIO Zener 27V 5%	1902-0968	1
VR18	DIO Zener 56V 5%	1902-0597	1
W1,2	Wire	8250-0005	2
Y1	XTAL 3MHz	0410-1496	1
	Screw 6-32 x .375	2360-0495	2

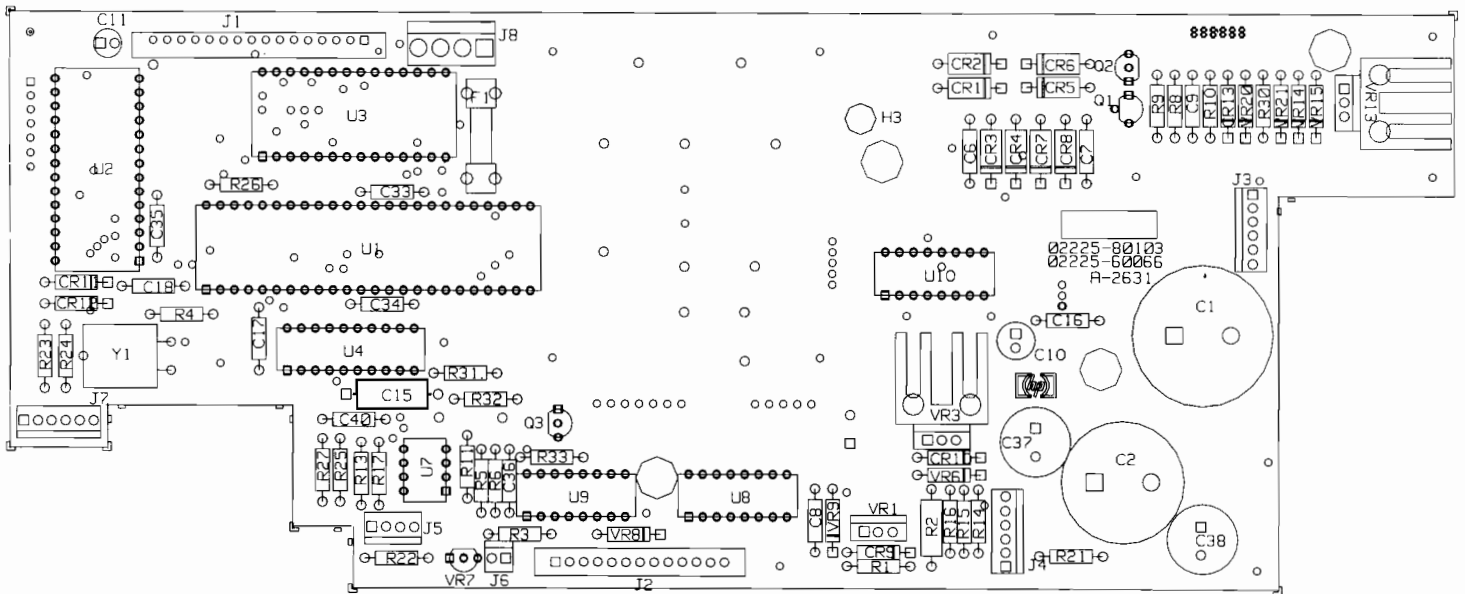

Figure 11-7. Earlier Version 2225C Main Logic PCA Assembly Drawing

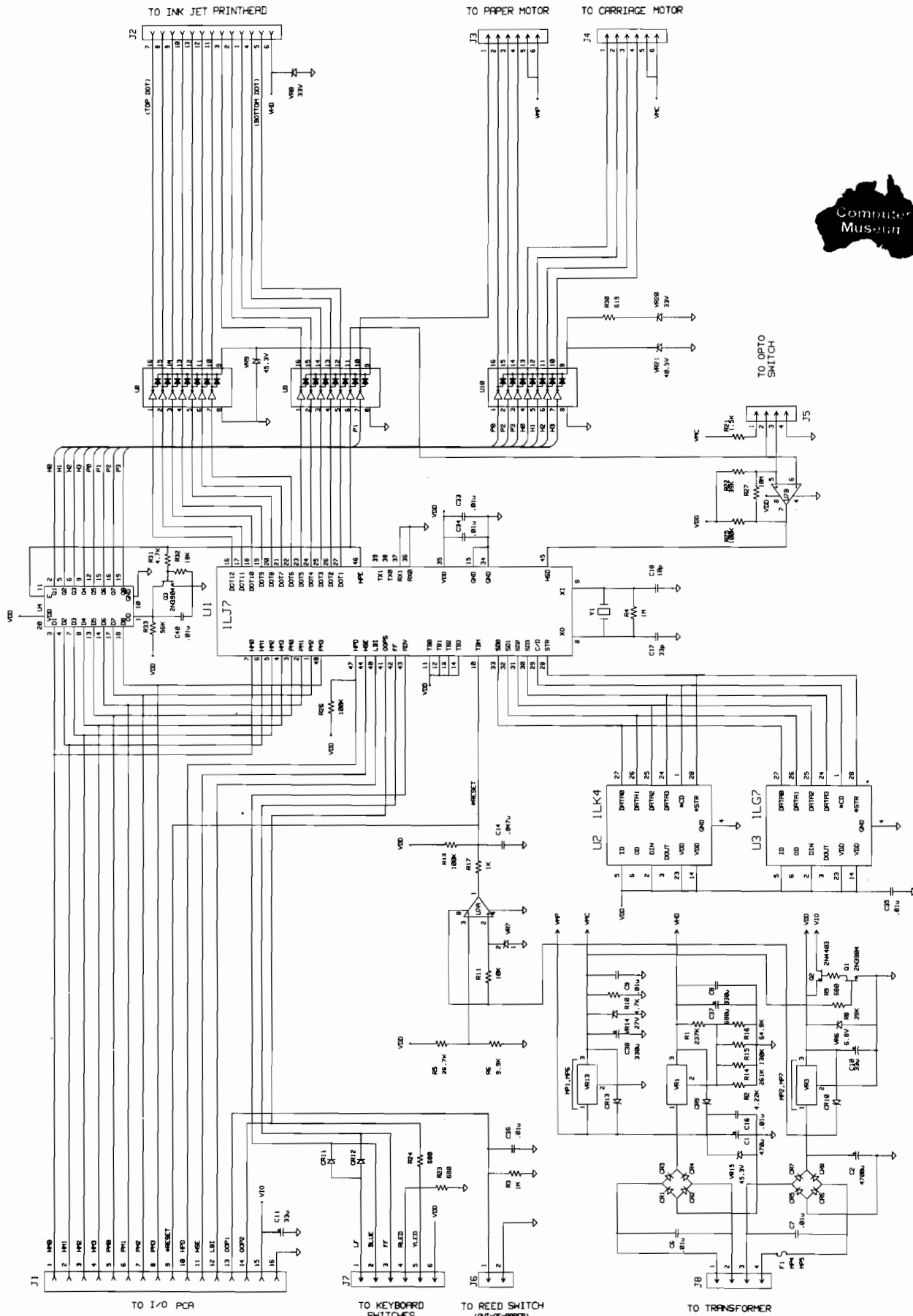

Figure 11-8. Earlier Version 2225C Main Logic PCA Schematic

Table 11-3. Earlier Version 2225C I/O PCA Part List

Fig 11-9 Ref	Part Description	Part Number	Qty
C1,2	CAP .01uF 20%	0160-4554	2
C3	CAP 470pF 5%	0160-4808	1
C4	CAP 1000pF 20%	0160-4532	1
J1	CONN 36P Centronics	1252-0142	1
J2	CONN 16P Rt Angle	1251-8841	1
MP1	SPACER I/O	02225-40042	1
R1,2	RES NETWORK SIP	1810-0277	2
R3	RES NETWORK 100K x 9	1810-0281	1
R4,5	RES 100 Ohm 5%	0683-1015	2
S1	SW 8 Pos SPST	3101-2726	1
U1	IC MM74C374N	1820-2216	1
U2	IC SN74ALS1035N	1820-3437	1
U3	IC MM74C00N	1820-2210	1
U4	IC 74C74	1820-1753	1
U5	IC 74C240	1820-2566	1
U6	IC MM74HC14N	1820-3185	1

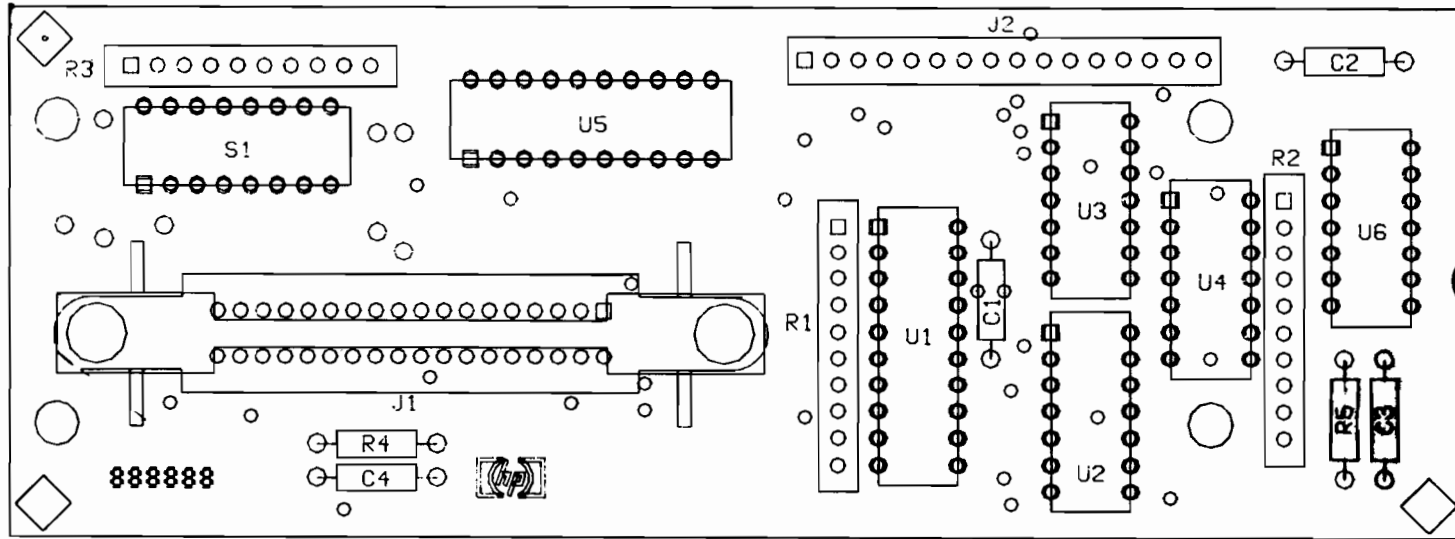

Figure 11-9. Earlier Version 2225C I/O PCA Assembly Drawing



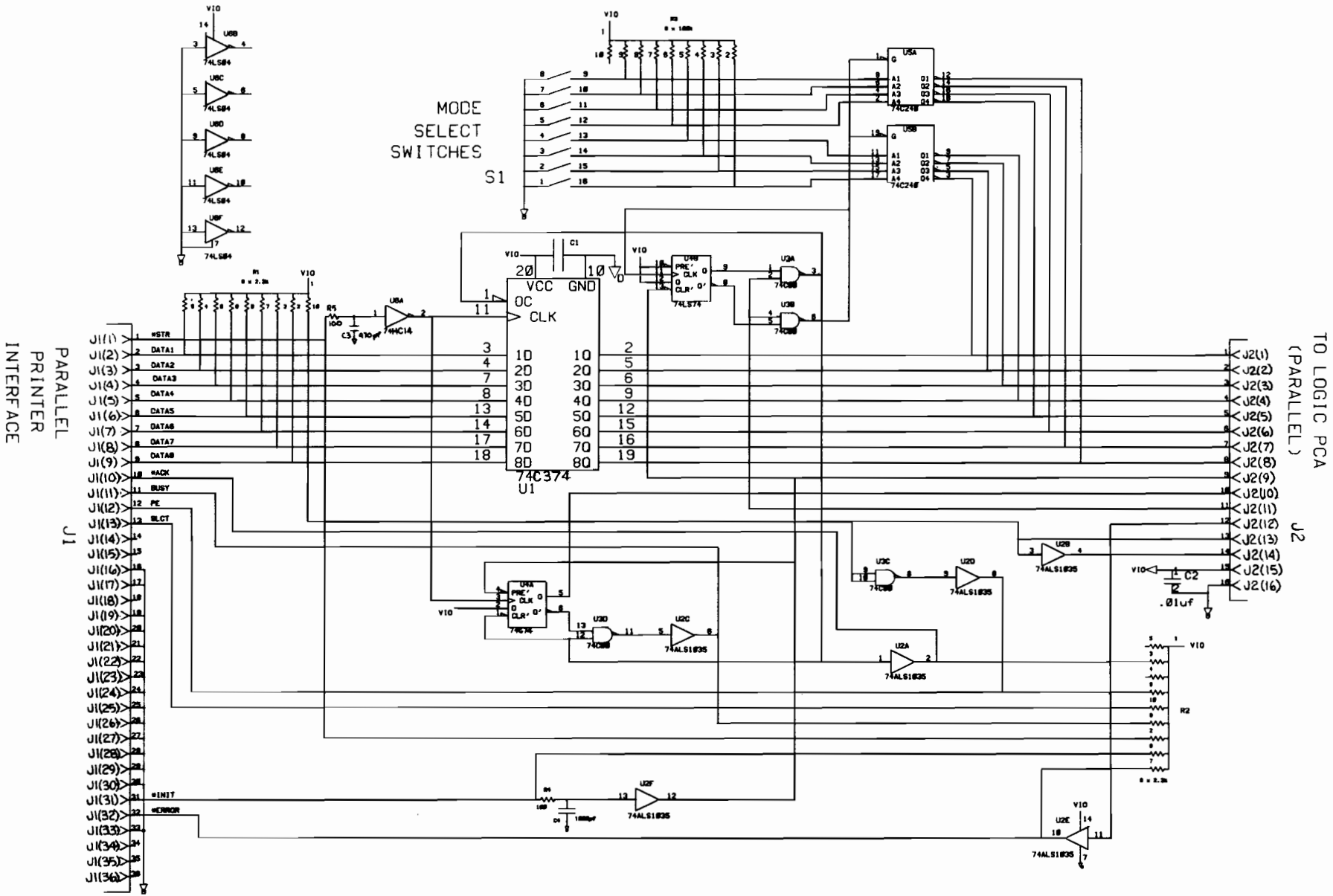
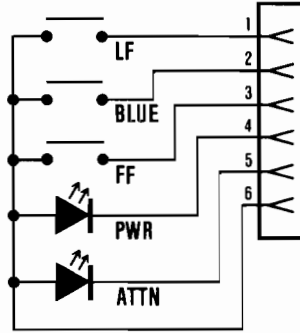
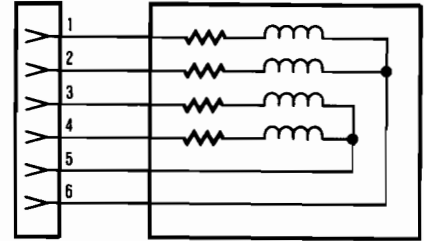

Figure 11-10. Earlier Version 2225C I/O PCA Schematic





Switch Assembly



Motor Assembly

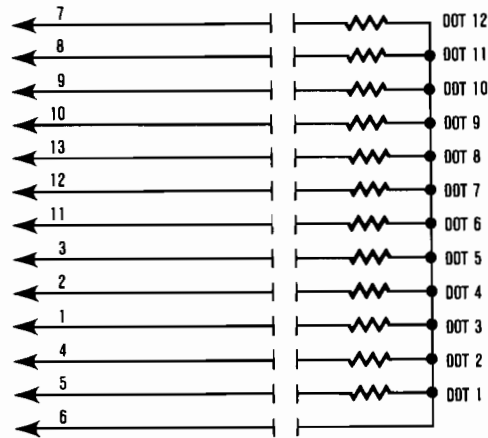

Carriage Assembly Print Head

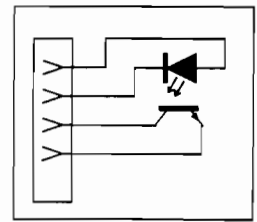

Home Switch Assembly

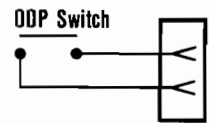

Mainframe Assembly

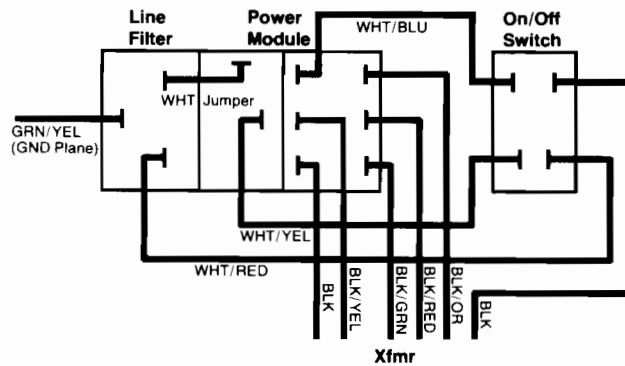

2225A/2225D with International Rear Panel

Figure 12-1. Miscellaneous Circuitry

# 2225A Main Logic PCA

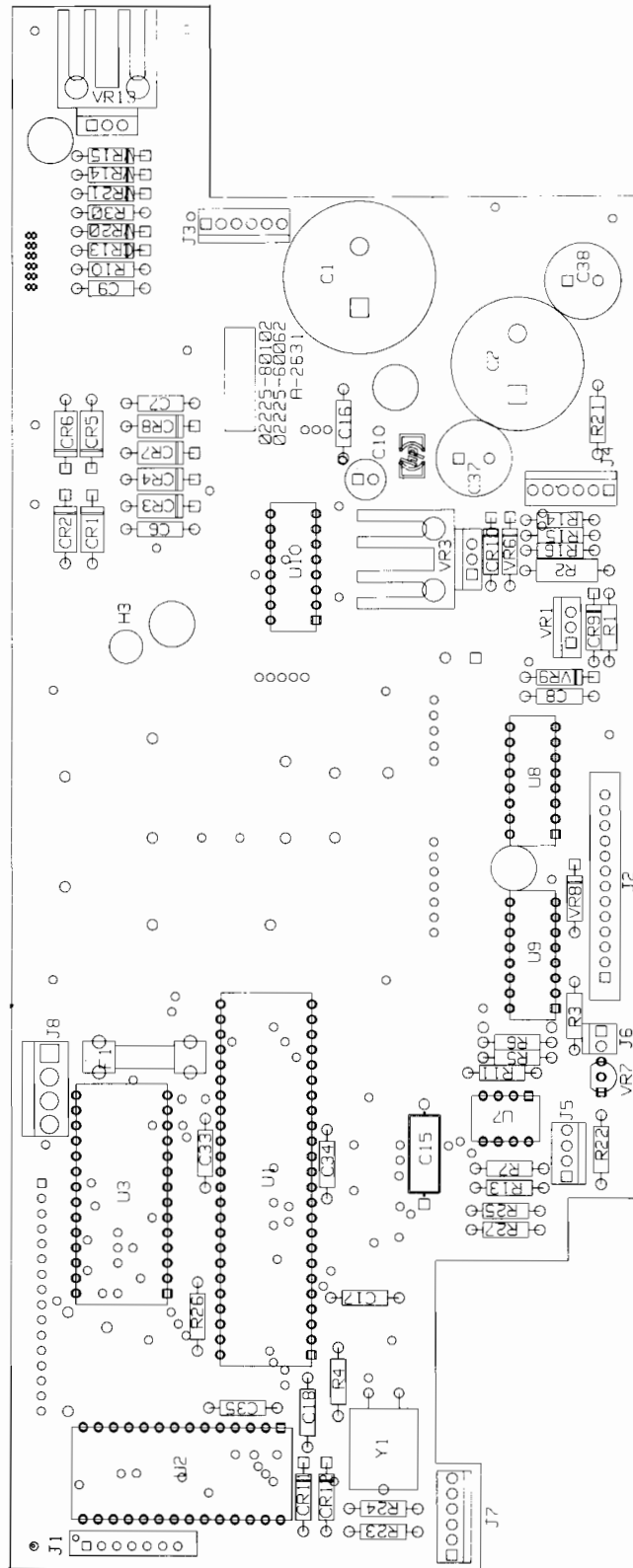

Figure 12-2. 02225-60062, 60063, & 60064 Assembly Drawing

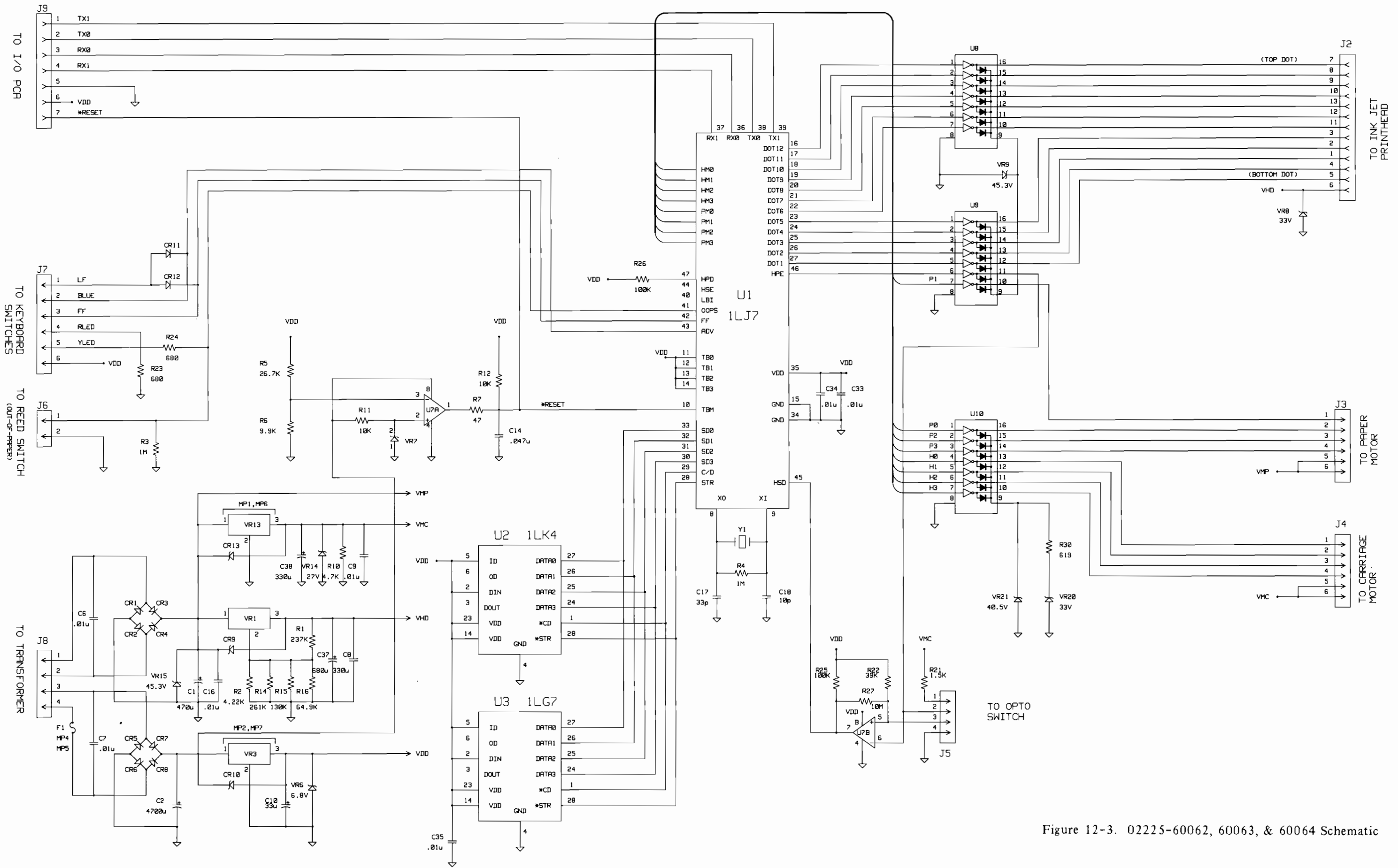

Figure 12-3. 02225-60062, 60063, & 60064 Schematic

# 2225A I/O PCA

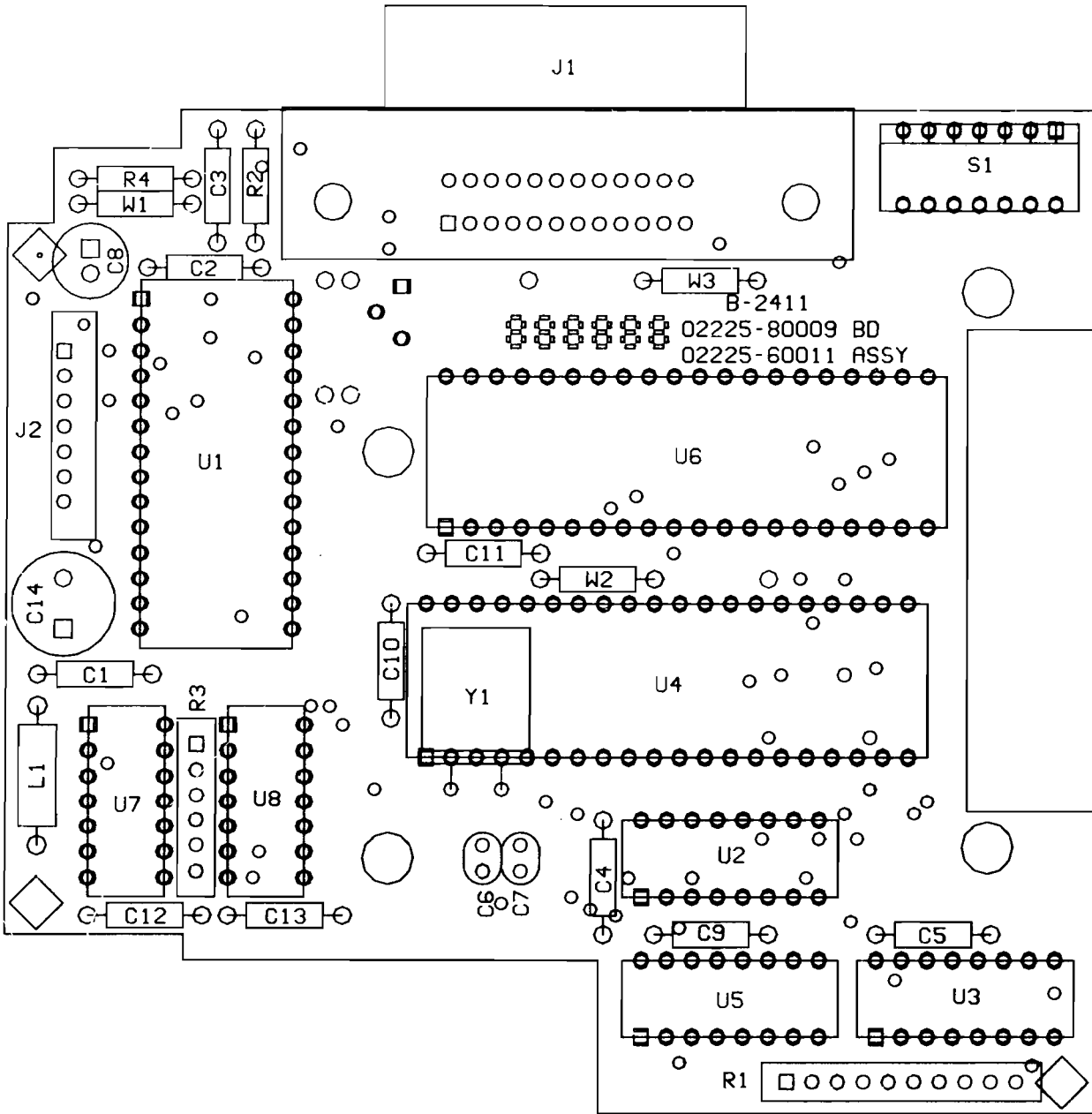

Figure 12-4. 02225-60011 Assembly Drawing

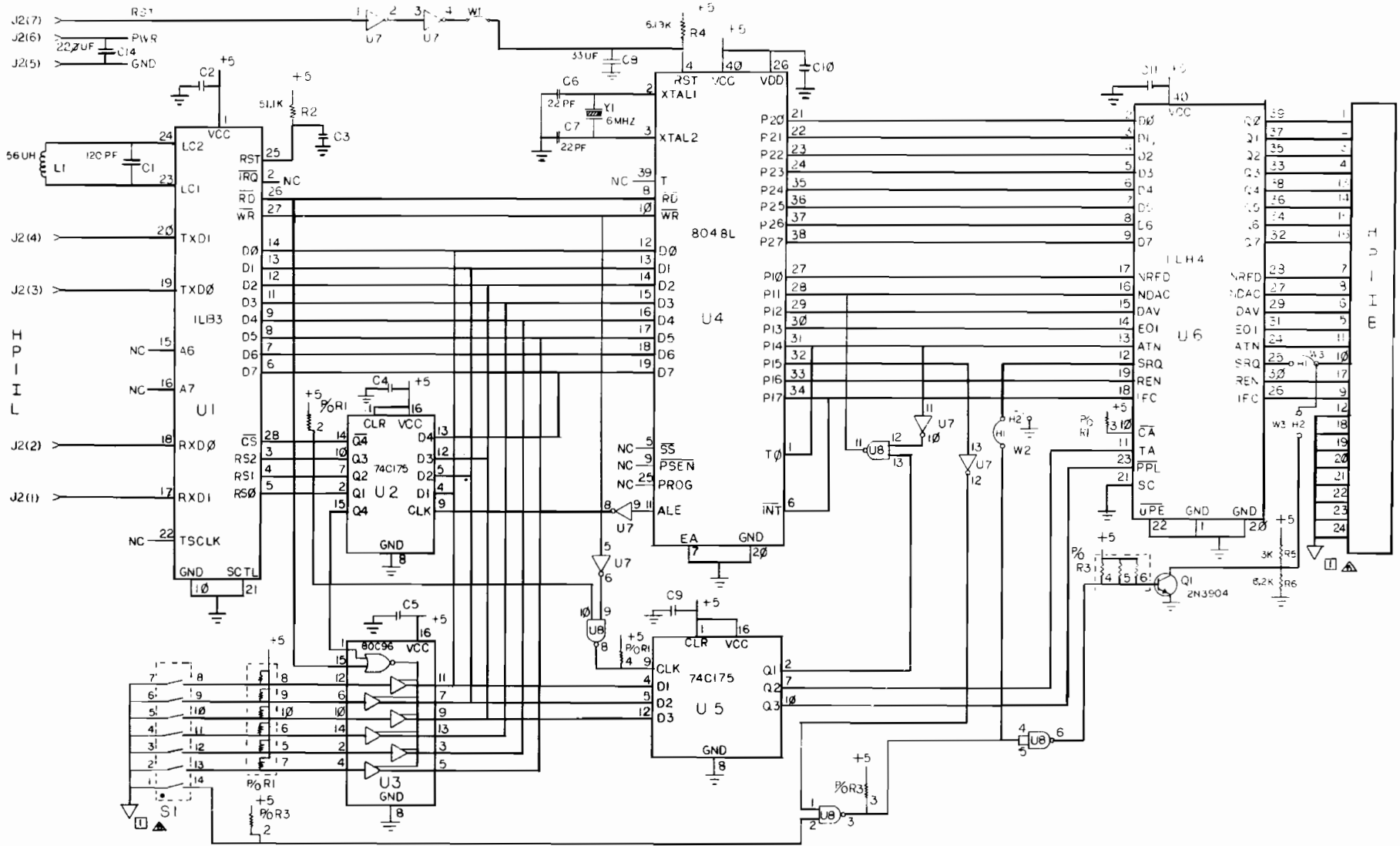

Figure 12-5. 02225-60011 Schematic

# 2225B PCA

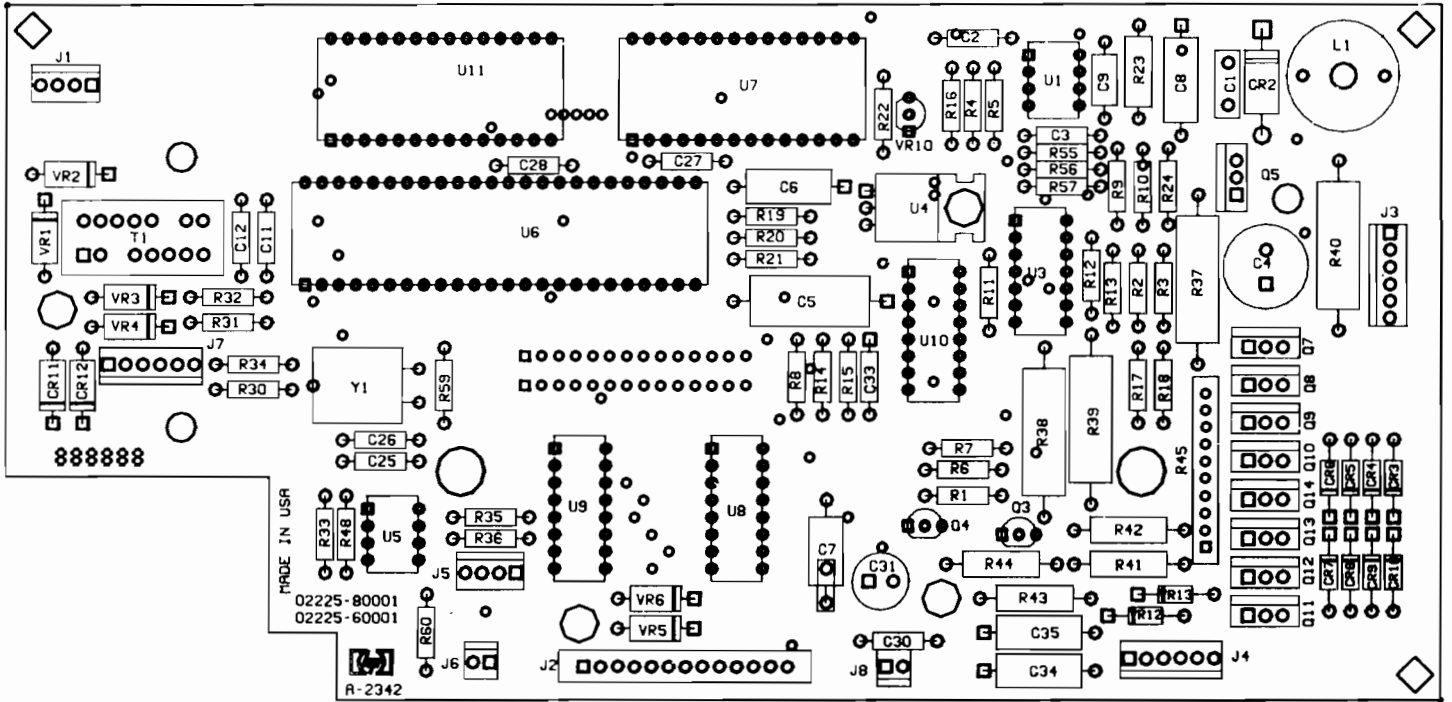

Figure 12-6. 02225-60001 Assembly Drawing

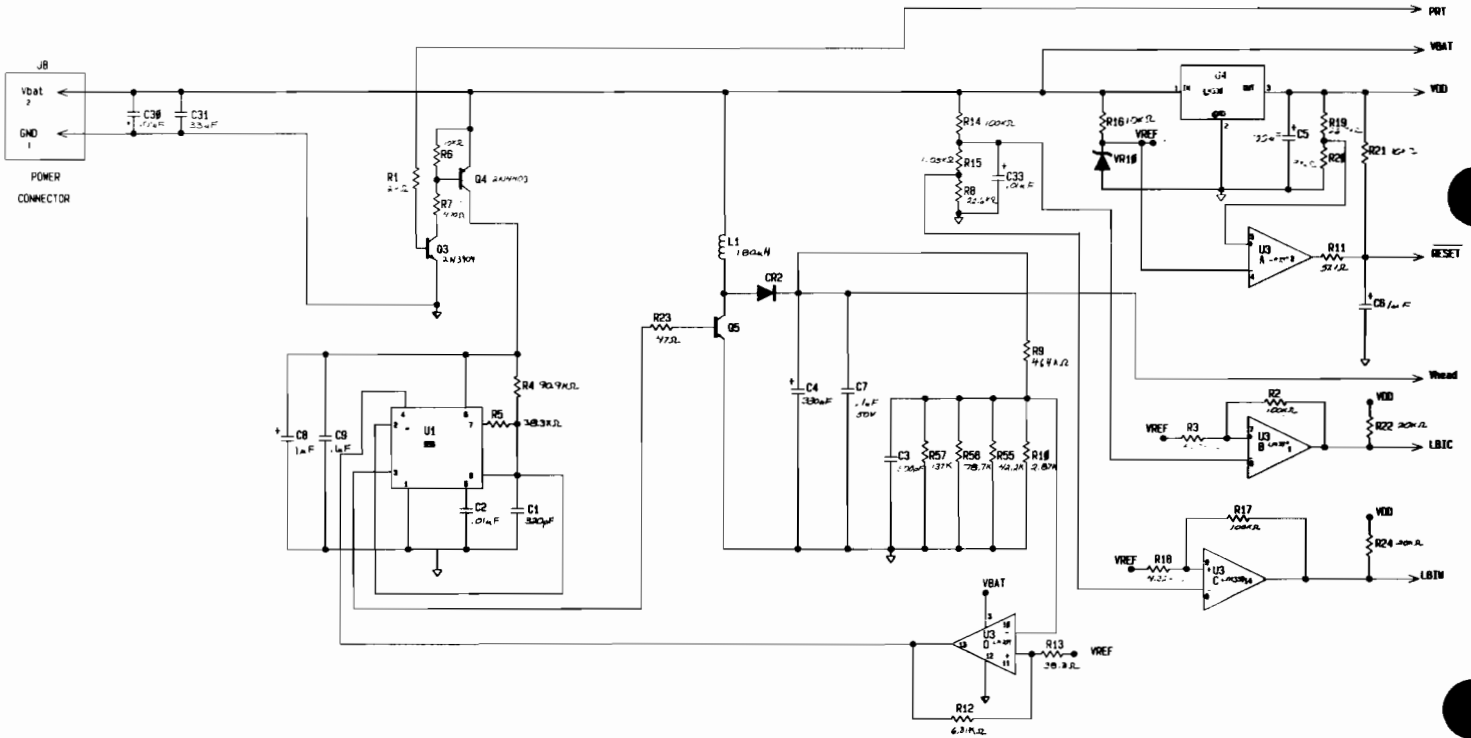

Figure 12-7. 02225-60001 Schematic  
(1 of 2)



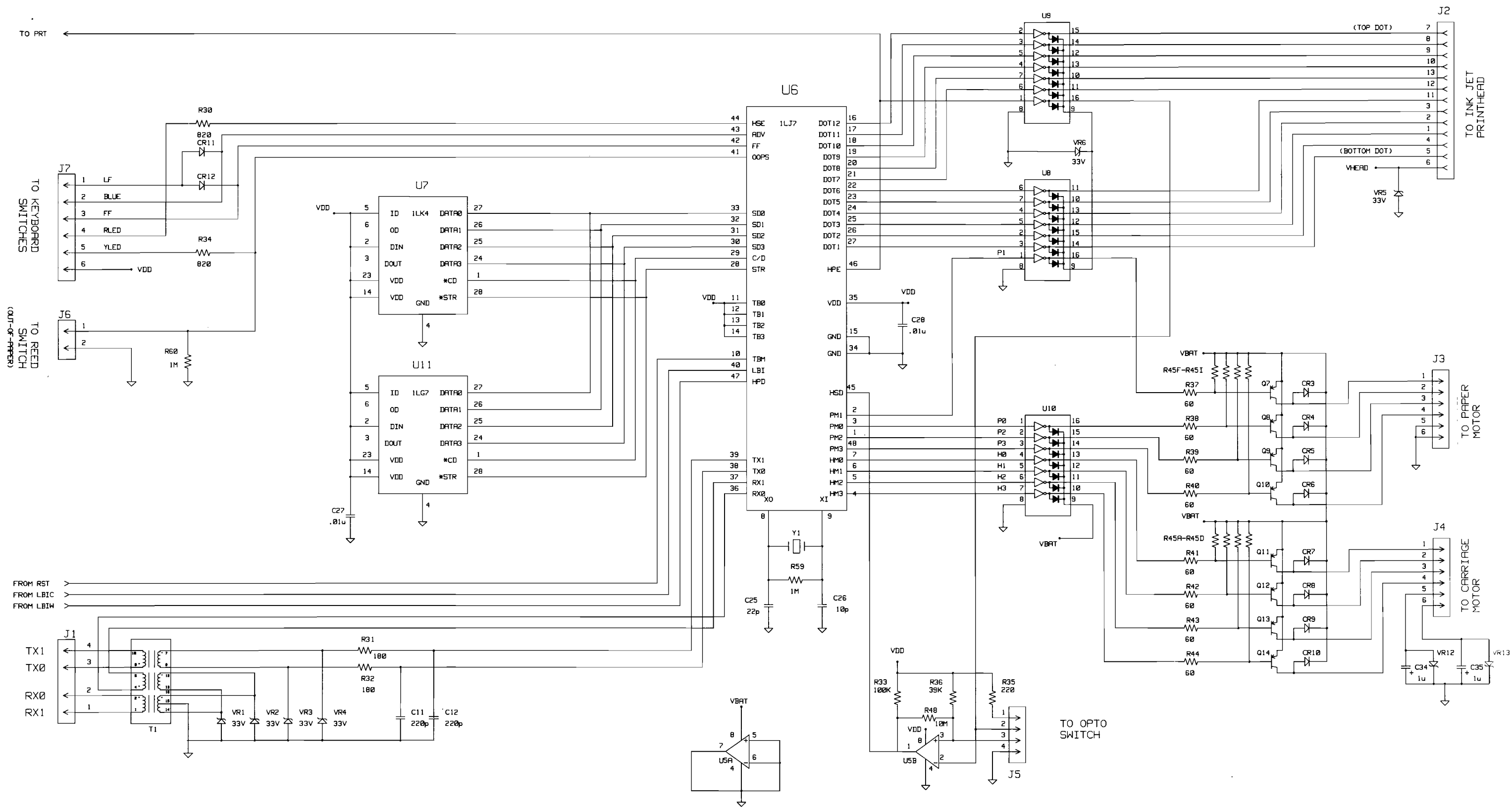

Figure 12-7. 02225-60001 Schematic  
(2 of 2)

# 2225C+ PCA

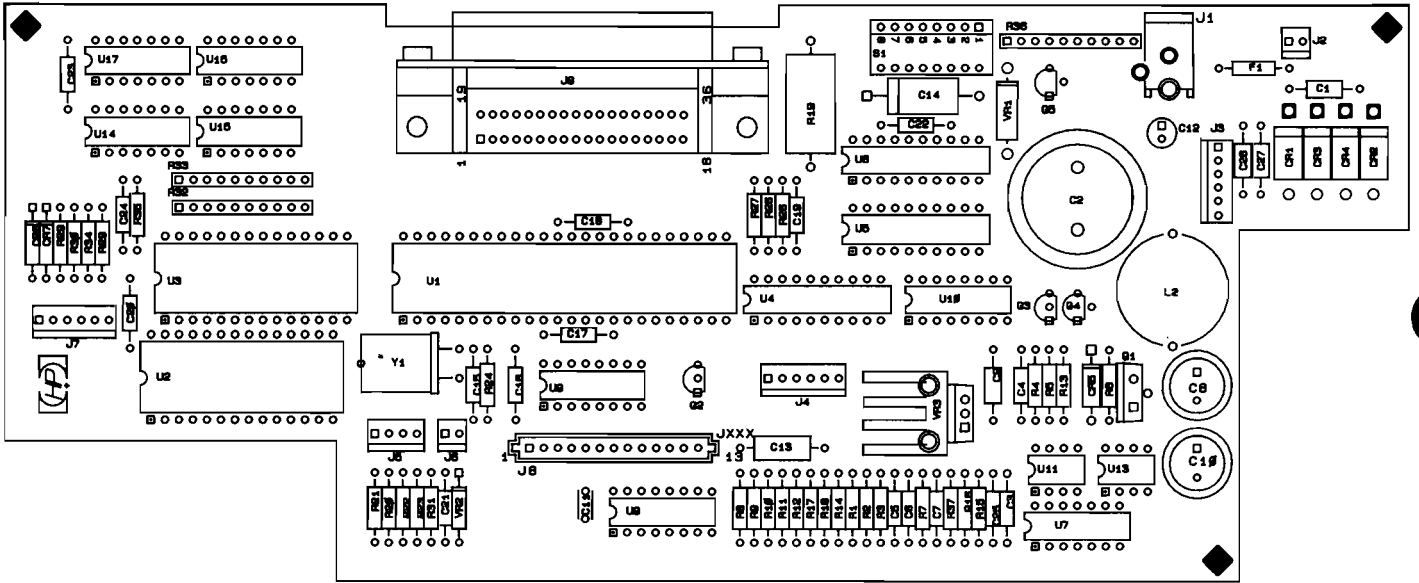

Figure 12-8. 02225-60072 Assembly Drawing

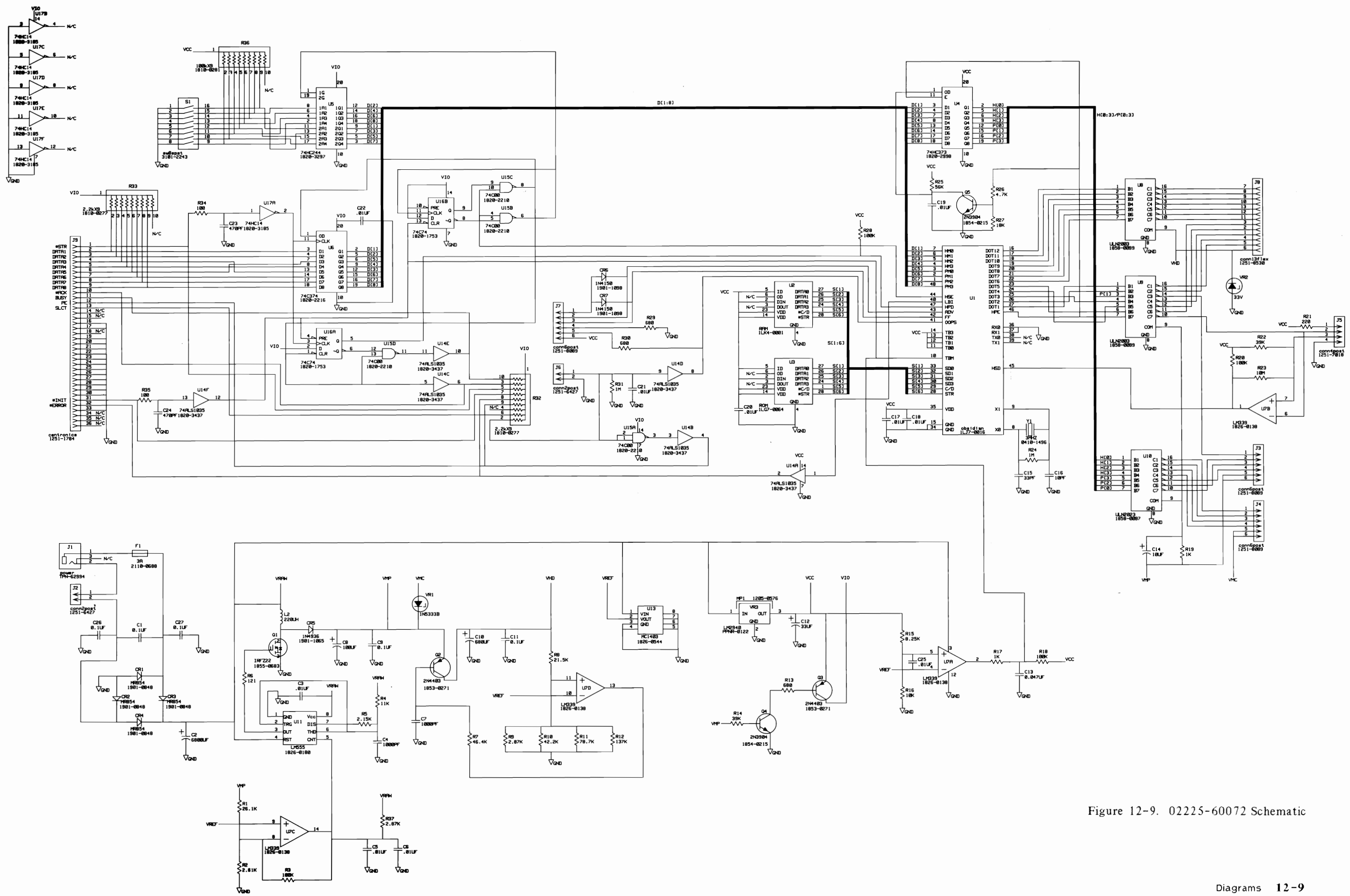

Figure 12-9. 02225-60072 Schematic

# 2225D Main Logic PCA

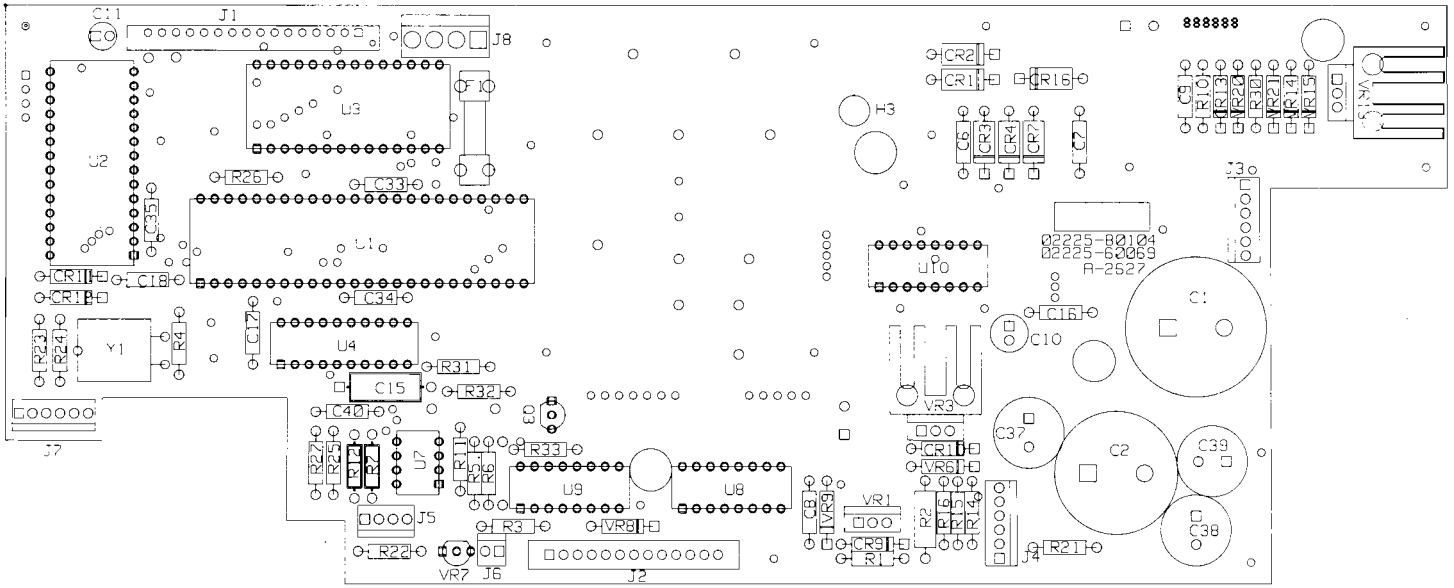

Figure 12-10. 02225-60069 & 60074 Assembly Drawing

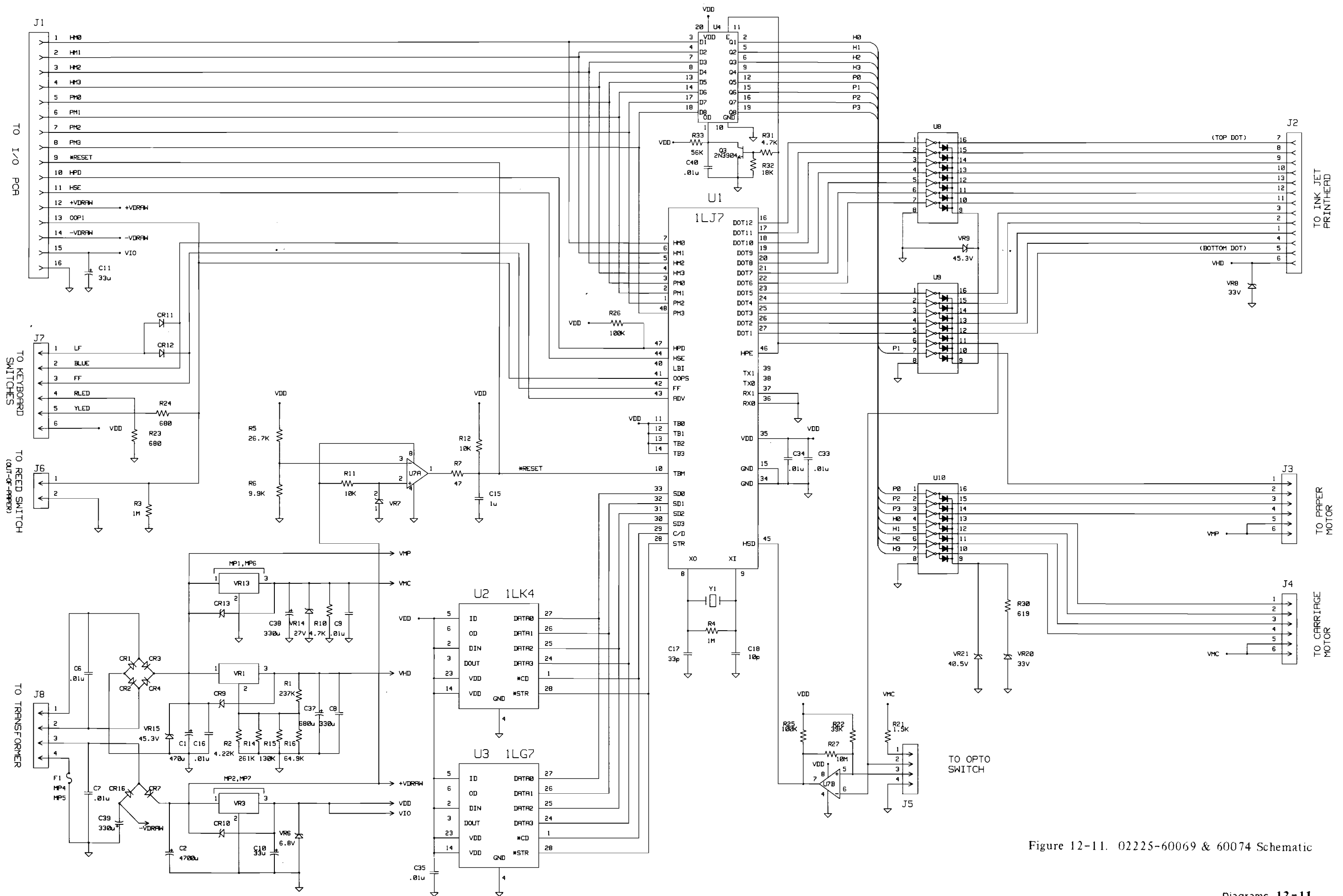

Figure 12-11. 02225-60069 & 60074 Schematic

# 2225D I/O PCA

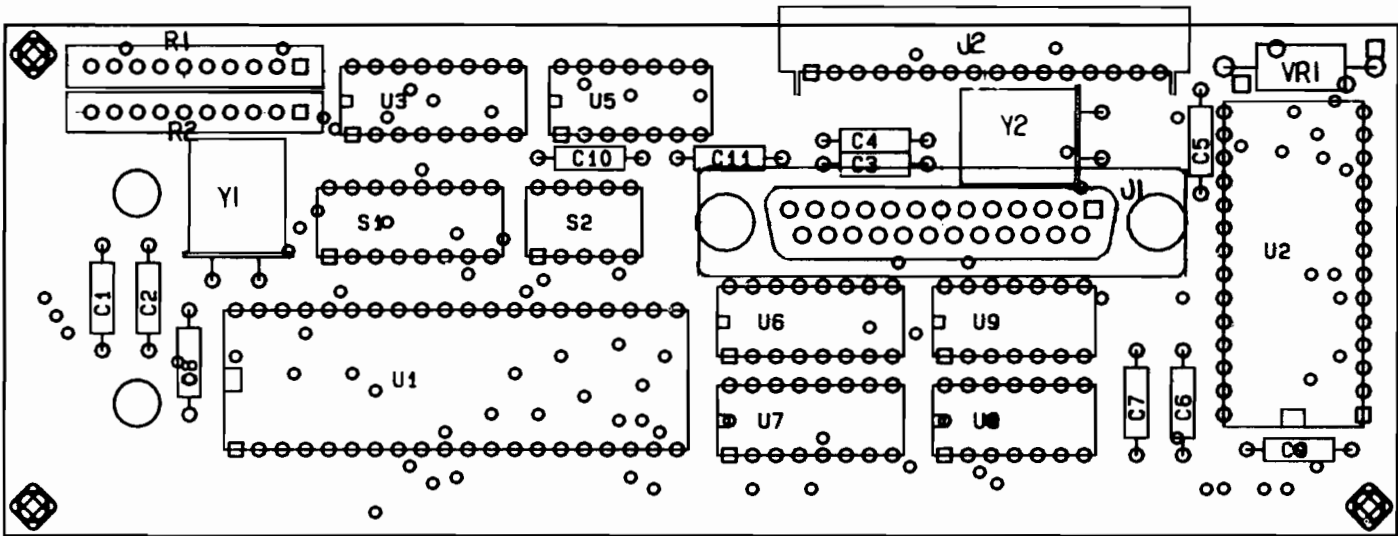

Figure 12-12. 02225-60019 Assembly Drawing

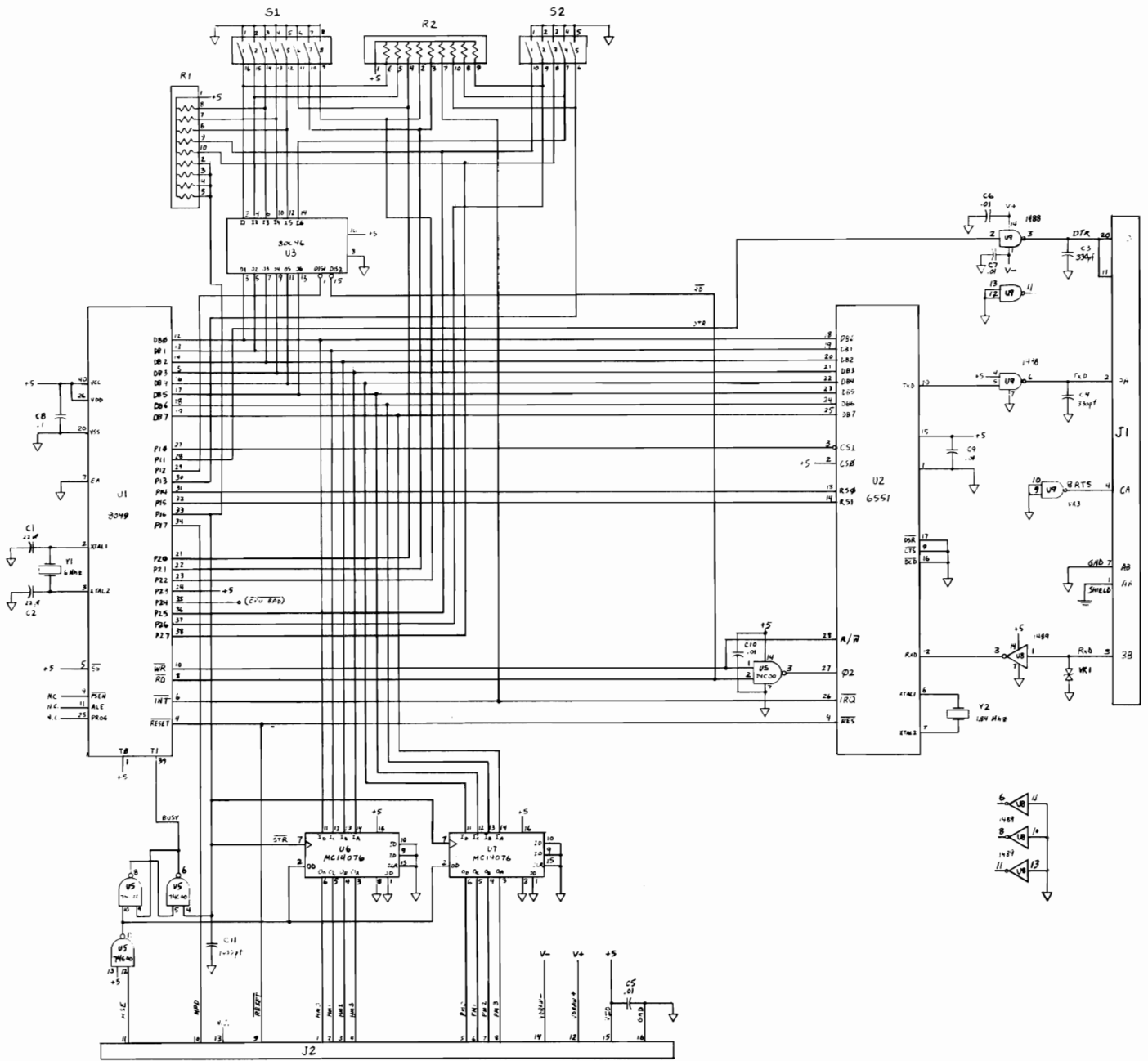

Figure 12-13. 02225-60019 Schematic

# 2225P Main Logic PCA

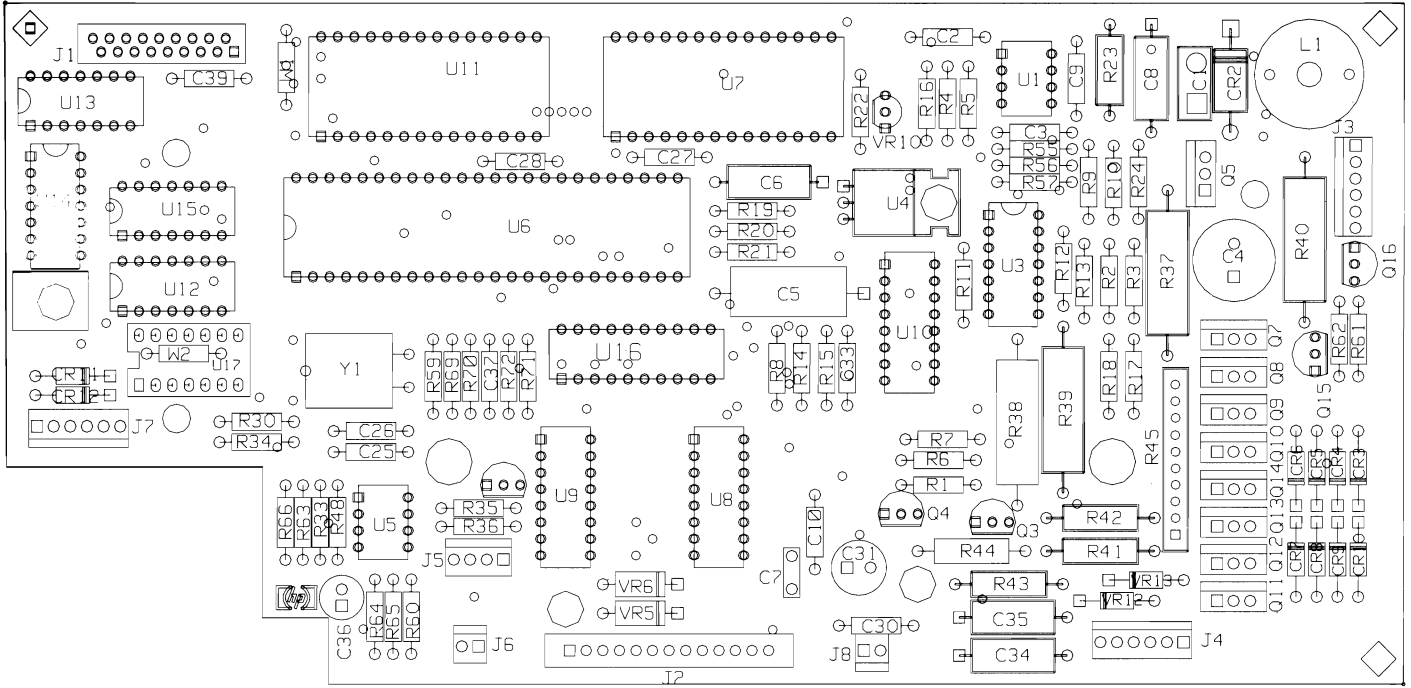

Figure 12-14. 02225-60061 Assembly Drawing

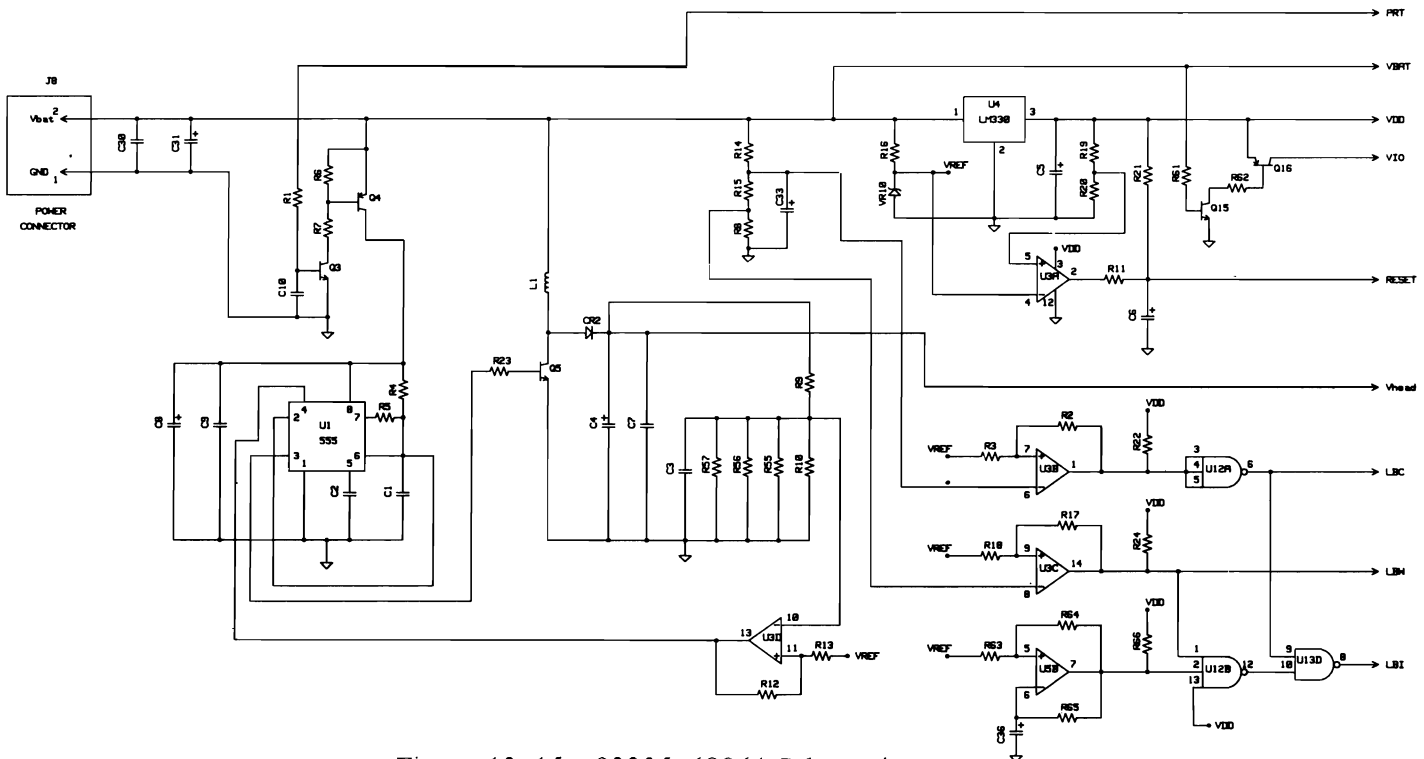

Figure 12-15. 02225-60061 Schematic  
(1 of 2)



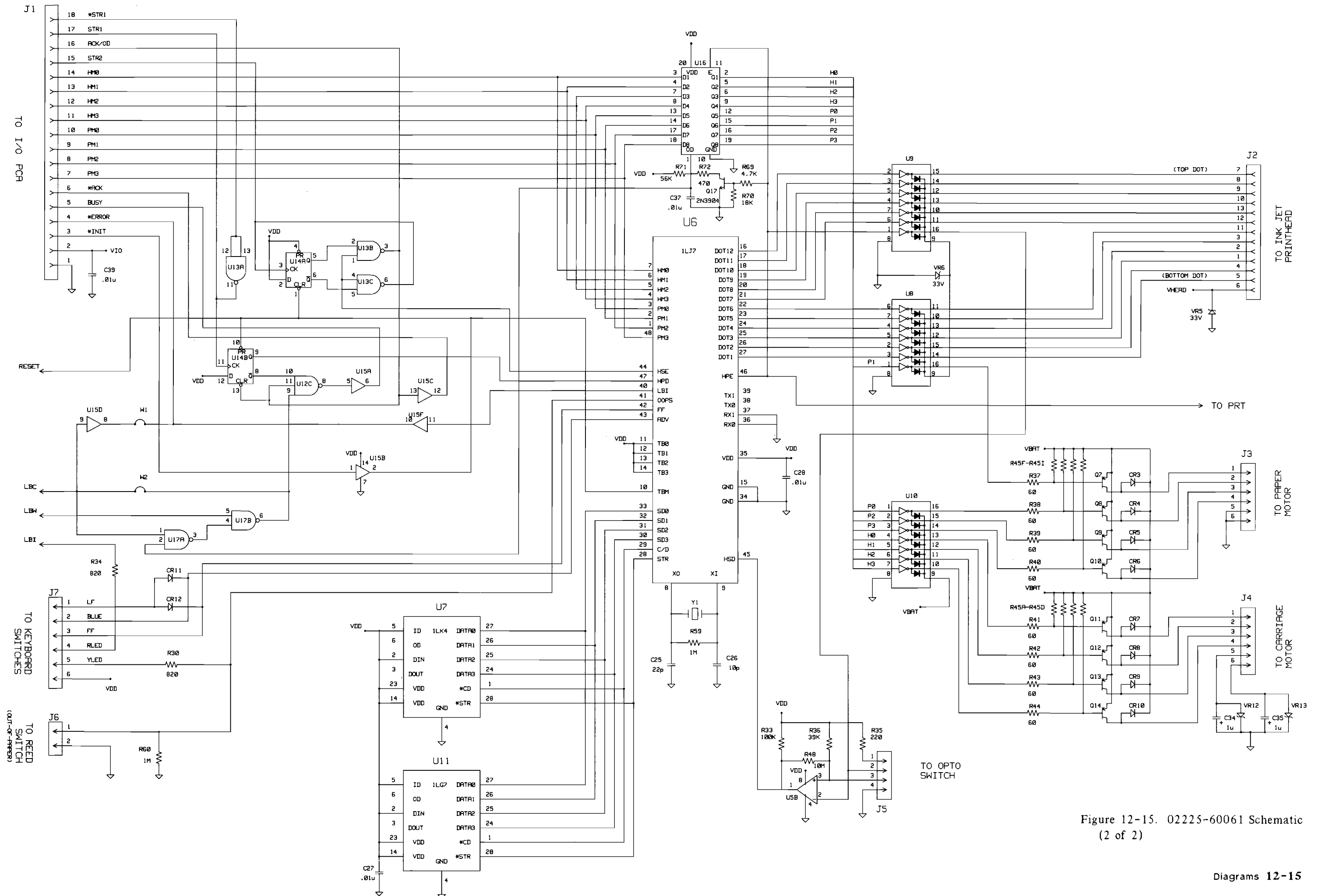

Figure 12-15. 02225-60061 Schematic (2 of 2)

# 2225P I/O PCA

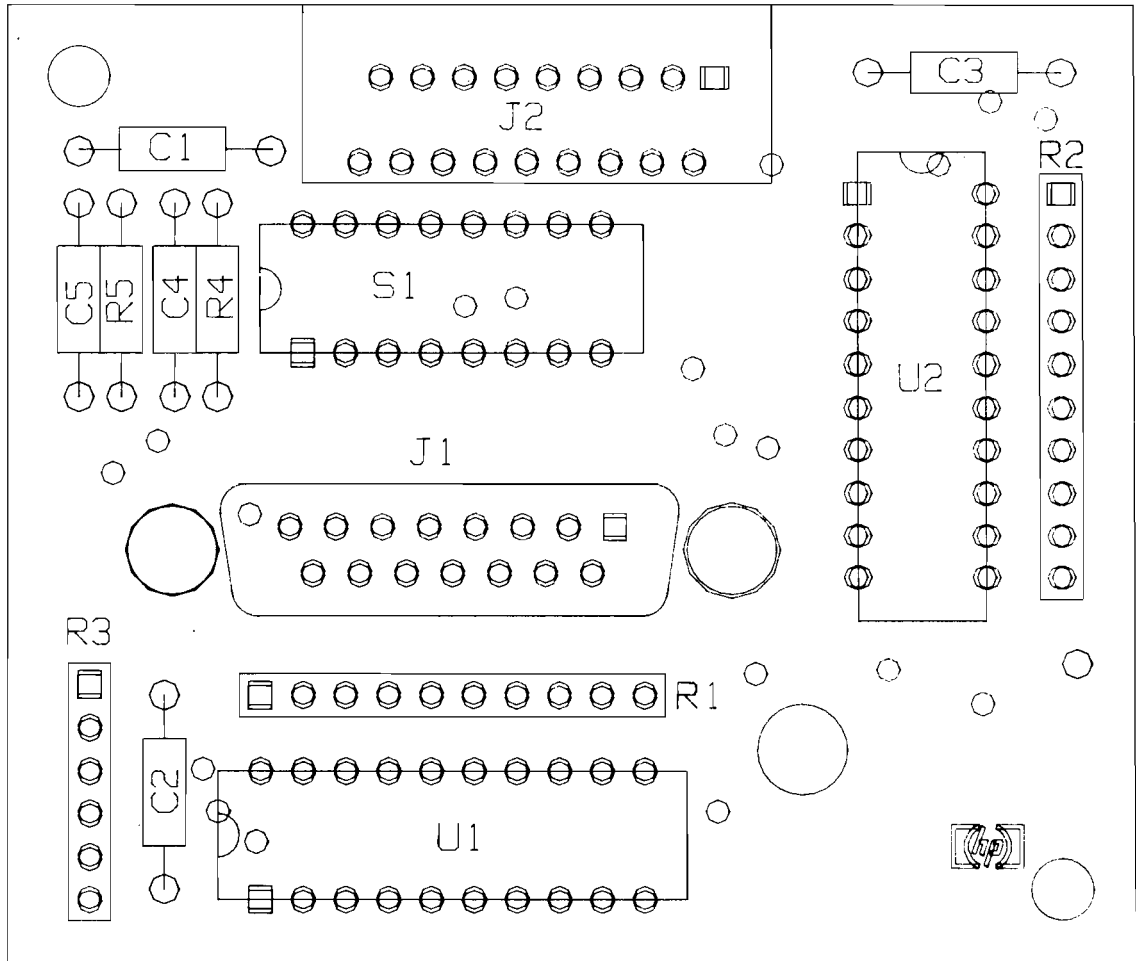

Figure 12-16. 02225-60078 Assembly Drawing

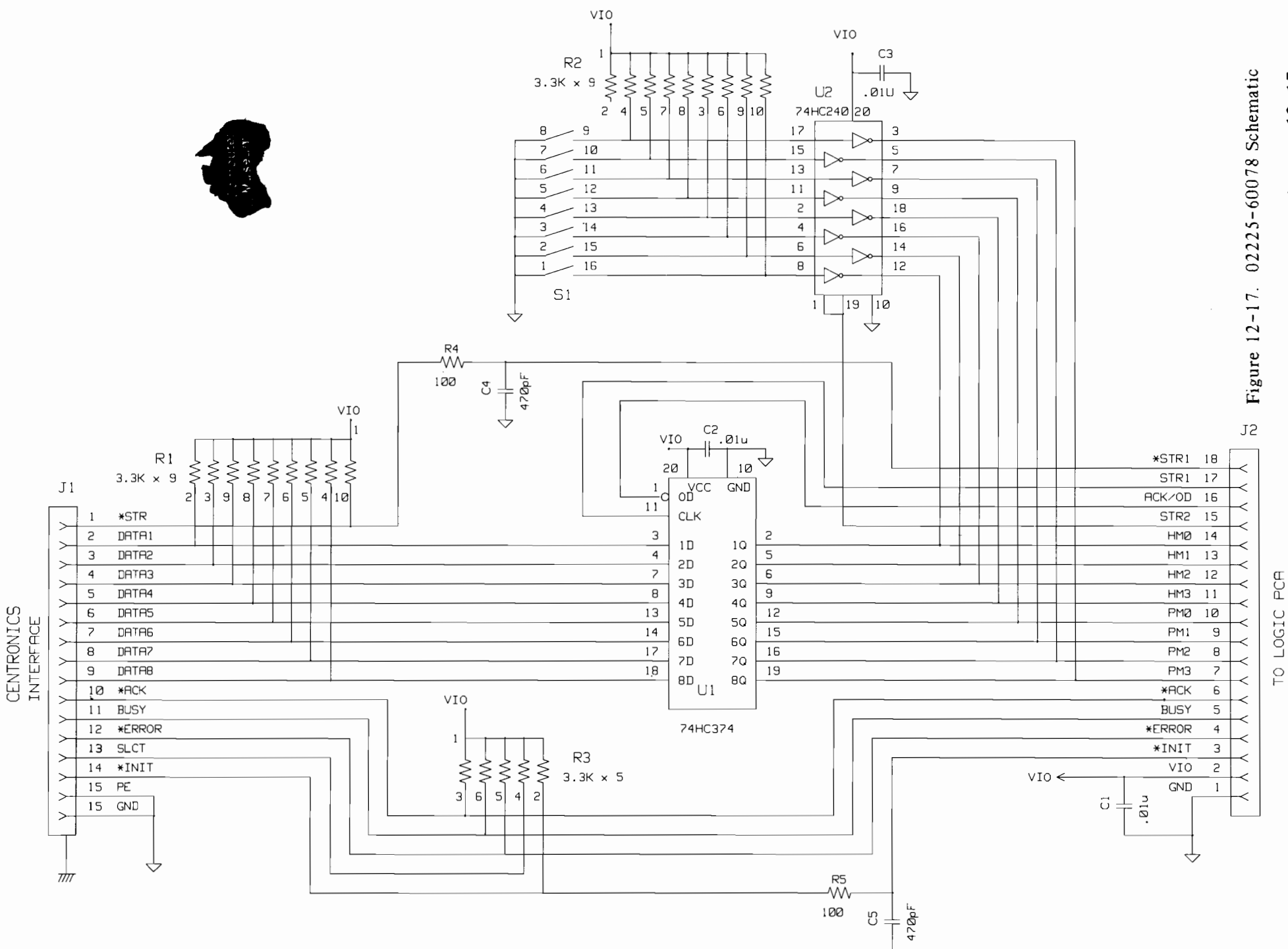

Figure 12-17. 02225-60078 Schematic

TO LOGIC PCA

# Index

## A

Accessories	1-4
Acquainted, Getting	1-8
Address Select Switches	3-6
Adjustments	7-1

## B

Backpanel	
Description	5-6
Identification	1-9
Bail	
Arm Adjustment	7-1
Arm Spring Removal	6-8
Assembly Removal	6-8
Battery Pack Information	1-13
Battery Characteristics	1-13
Signs of Battery Degradation	1-14
Description	5-3
Battery Pack Troubleshooting	8-15
Baud Rate Switches	3-10
Blue Key	1-12
Boost Converter Description	5-3

## C

Capabilities, Product	1-6
Carriage Assembly Removal	6-7
Carriage Motor Circuitry, Troubleshooting	8-9
Cartridge	
Installing the Print	3-5
Maintenance, Print	4-2
Priming the	4-3
Centronics I/O Description	5-9
Centronics Printers, Earlier Version	11-6
Character Set Switch Selection	3-8
Cleaning	4-4
Control Codes	
IBM/Epson Compatible	10-1
HP PCL	10-3
Control Switches, RS-232C	3-9

## D

Description, Functional	5-1
DIP Switches	3-6

## E

Earlier Version 2225C Printers	11-6
Electrical Specifications	2-2
Environmental Specifications	2-3
Epson Compatible Control Codes	10-1

## F

Form Feed (FF) Key	1-12
Functional Description	5-1
Fuses and Voltage	
2225A & 2225D	3-2
2225B & 2225P	3-3
2225C	3-4

## G

Getting Acquainted	1-8
Grit Wheel Removal	6-6

## H

Handshaking	
RS-232C I/O	5-11
Centronics	5-9
Head Drive Logic, Print	5-4
Hints, Troubleshooting	8-17
History, Product	11-1
Home Switch	
Description	5-6
Removal	6-11
Troubleshooting	8-12
HP PCL Compatible Control Codes	10-3
HP-IB Address Selection	3-7
HP-IB I/O Description	5-8
HP-IL I/O Description	

## I

IBM/Epson Compatible Control Codes	10-3
Included, Items	3-1
Identification by Backpanel	1-9
Installation and Configuration	3-1
Interface Specifications	1-7
Installing/Replacing the Fuse	3-3
Installing the Print Cartridge	3-5
Items Included	3-1
I/O Description	
HP-IB	5-8
HP-IL	5-8
Centronics	5-9
RS-232C	5-11

## K

Kernel, Troubleshooting the	8-8
Keypad Description	5-6
Keypad Lights and Keys	1-11
Keys, ThinkJet	1-12

---

## L

Lights and Keys, Keypad	1-11
Line Feed (LF) Key	1-12
Loading Paper	3-4

---

## M

Manual Overview	1-2
Main Logic PCA Troubleshooting	8-6
Maintenance	4-1
Maintenance Philosophy	4-1
Mechanism Description	
Carriage Drive	5-14
Heat Dissipation	
Paper Advance	5-13
Paper Path	5-14
Mechanism Removal	6-2
Mechanism Subassembly Removal	
Bail Assembly	6-8
Carriage Assembly	6-7
Grit Wheel & Tractor Pinwheels	6-6
Home & Out of Paper Switches	6-11
Pinch Roller	6-10
Microprocessor Description	5-1
Mode Select Switches	3-8
Motor Drive Description	5-4
Multiple Print Cartridge Failures	4-3

---

## N

Nonprinting Self Test	8-1
-----------------------	-----

---

## O

Ordering Information	9-1
Out-of-Paper Switch Removal	6-11
Overall Troubleshooting	8-4

---

## P

Paper, Loading Paper	
Parity/Word Length	3-9
Parts, Replaceable	9-1
PCA Removal	
2225A	6-3
2225B	6-3
2225C	6-4
2225D	6-4
2225P	6-5
Physical Specifications	2-1
Pinch Roller Removal	6-10
Pinout	
RS-232C I/O	5-12
Centronics	5-10
Power Information	3-2

---

Power Supply	
Adjustment	7-2
Description	5-2
Voltage Levels	8-6
Print Cartridge	
Installing	3-5
Maintenance	4-2
Multiple Failures	4-3
Priming	4-3
Print Head Drive Logic	
Description	5-4
Troubleshooting	8-14
Print Mechanism Description	
Carriage Drive	5-14
Heat Dissipation	5-14
Paper Advance	5-13
Paper Path	5-14
Removal	6-2
Printing Self Test	8-2
Product	
Description	1-1
History	11-1
Information	1-1
Product Specifications	1-6
Capabilities	1-6
Electrical	2-2
Environmental	2-3
Interface	1-7
Physical	2-1
PWR Light Description	1-11

---

## R

Reference	10-1
Removal and Replacement	
Top Cover	6-2
Mechanism	6-2
2225A PCAs	6-3
2225B PCA	6-3
2225C PCA	6-4
2225D PCAs	6-4
2225P PCAs	6-5
Mechanism Subassembly	6-6
Replaceable Parts	9-1
Reset Circuitry Description	5-7
Roller Removal, Pinch	6-10
RS-232C I/O Description	5-11
RS-232C Switches	3-9
Run the Self Test	3-6

---

## S

Select Switches	
Character Set	3-8
HP-IB Address	3-7
Mode Select	3-8
RS-232C	3-9
Self Test	
Explanation	8-1
Running the	3-6
Setting the Voltage	3-2
Signs of Battery Degradation	1-14
Site Planning and Requirements	2-1
Specifications, Product	1-6
Spring Removal, Bail Arm	6-8

Stepper Motor Drive	5-4
Supply Description, Power	5-2
Switch Assembly, Home	
Description	5-6
Removal	6-11
Switch Removal, Out-of-Paper	6-11
Switches, DIP	3-6

---

## T

Test Equipment and Tools	1-14
Top Cover Removal	6-2
Tractor Pinwheel Removal	6-6
Troubleshooting	8-1
Battery Pack	8-15
Carriage Motor	8-9
Home Switch Circuitry	8-12
Kernel	8-8
Main Logic	8-6
Overall	8-4
Print Head Circuitry	8-14
Troubleshooting Hints	8-17

---

## V

View	
Backpanel	1-9
Front	1-8
Internal	1-8
Voltage, Fuses and	
2225A & 2225D	3-2
2225B & 2225P	3-3
2225C	3-4
Voltage Levels	8-6

---

## W

Word Length, Parity	3-9
---------------------	-----

---

## Y

Yellow Light Description	1-11
--------------------------	------

---

## Z

Z-Fold Paper, Loading	3-4
-----------------------	-----



Manual Part Number 02225-90079  
Printed in U.S.A. November 1986





**HEWLETT-PACKARD**

**HP 2225**

**ThinkJet**

**DC Parallel Printer Specifications**

## DC Parallel Interface Specifications

The DC parallel ThinkJet uses a standard parallel printer interface which is compatible with many personal computers.

### Printer Connector Pin Assignments

The printer interface connector is a female 15 pin D subminiature connector.

#### Pin Assignments

Pin No.	Signal	Direction	Description
1	<u>Strobe</u>	In	A low pulse of width greater than 0.5 us causes the printer to read one byte of data.
2	DATA1	In	Data bit 1
3	DATA2	In	Data bit 2
4	DATA3	In	Data bit 3
5	DATA4	In	Data bit 4
6	DATA5	In	Data bit 5
7	DATA6	In	Data bit 6
8	DATA7	In	Data bit 7
9	DATA8	In	Data bit 8
10	<u>Acknlq</u>	Out	The printer sends a LOW pulse to indicate that it has accepted a byte of data and is ready for more data.
11	Busy	Out	A HIGH logic level indicates the printer cannot receive data due to data entry, a full buffer, or error status.
12	OOP	Out	A HIGH logic level indicates the printer is out of paper
13	<u>SLCT/Error</u>	Out	Always High
14	<u>Reset</u>	In	A LOW pulse of width greater than 40 us resets the printer and clears the print print buffer.
15	Logic Gnd		
Shell	Shield Gnd		

### Timing Diagram for DC parallel I/O

The timing diagram below illustrates the data and handshake lines during the transfer of one data byte to the printer. DATA 1 through DATA 8 and the strobe line are driven by the computer, the BUSY and ACK lines are driven by the printer.

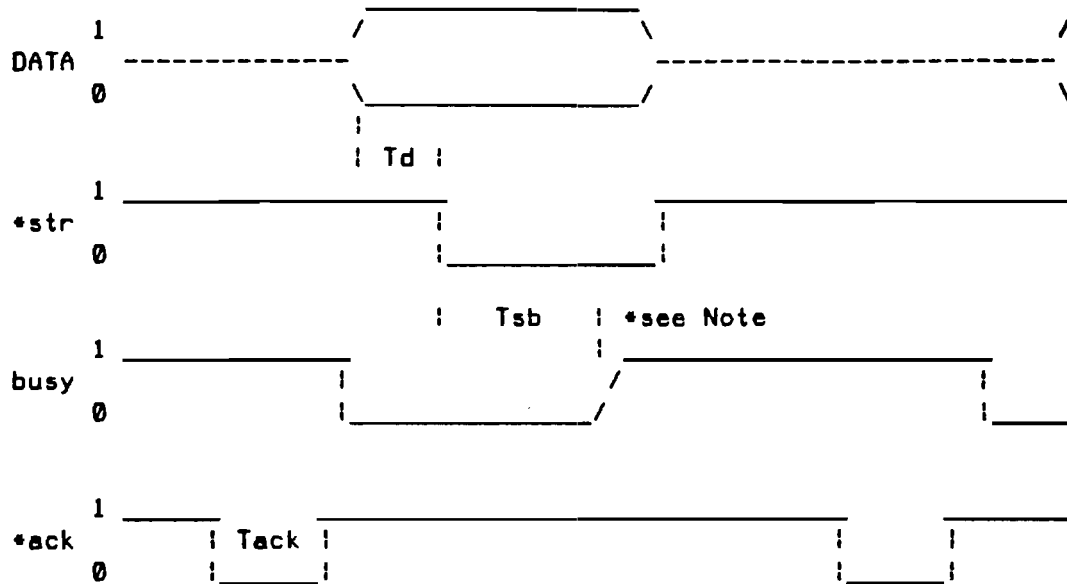

$T_d$  (data setup) = 20 ns min

$T_{sb}$  (strobe to busy) = 300 ns max

$T_{ack}$  (\*ack pulse width) = 5 us typ

$T_{rb}$  (reset to busy) = 435 ns max

Note: Timing does not include rise time due to cable capacitance, if known add  $.7RC$  to max time. ( $R_{pullup} = 3.3K$ )

## **Battery Life**

The battery in the DC parallel ThinkJet is a 1.2 amp-hour NiCad. Under normal operating conditions, a fully charged battery pack is capable of the following:

- o Continuous printing without recharger: ~ 2 hours (about 200 pages)
- o Continuous printing with recharger: ~ 2.6 hours (about 275 pages)
- o Storage: several weeks without recharging
- o Not printing with power left on (no recharges): 2 days

To maximize battery pack life, recharge the battery pack only when it is nearly discharged, as indicated by a flashing printer power light. Approximately 11 hours is required to recharge a battery pack fully. The battery pack may be charged in or out of the printer.

If additional printing is attempted with a discharged pack and recharger, an approximate 20% printer duty cycle will result as the battery pack charges enough to allow printing and discharges again to low battery cutoff in the process of printing.

**Note:** If printer is used with recharger plugged in on a permanent basis and battery pack is not occasionally fully discharged, then the battery pack should be replaced every 8 months due to NiCad memory effect which reduces the amount of charge the battery can hold.

## **Environmental Specifications**

The printer should be maintained and operated under the following environmental conditions:

- o Operate only at temperatures between 50 and 104 deg F (10 and 40 deg C)
- o Recharge only at temperatures between 50 and 104 deg F (10 and 40 deg C)
- o Store at temperatures between -4 and 140 deg F (-20 and 60 deg C)
- o Operate in relative humidity between 10% and 90%

## Operational Differences with 2225C

- o No printing self-test via power cycling with FF or LF buttons pressed. A self-test may be initiated via the escape sequence ESC z.
- o Reset sequence takes slightly longer.

## ThinkJet to IBM Cable Wiring

Male 15 pin D subminiature

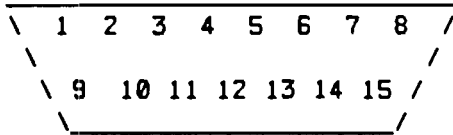

Male 25 pin D subminiature

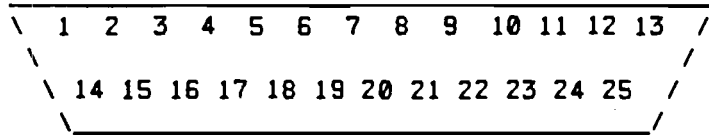

1  
2  
3  
4  
5  
6  
7  
8  
9  
10  
11  
12  
13  
14  
15

|  
|  
|  
|  
|  
|  
|  
|  
|  
|  
|  
|  
|  
|  
|

1  
2  
3  
4  
5  
6  
7  
8  
9  
10  
11  
12  
13 & 15  
16  
18