

Network Analysis

Specifying calibration standards for the HP 8510 network analyzer

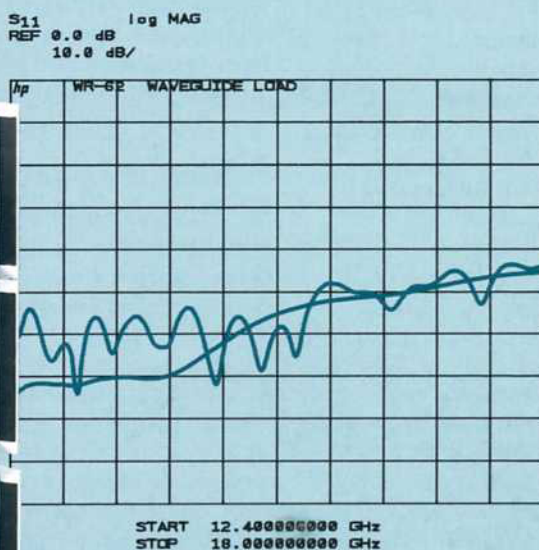

Known devices called calibration standards provide the measurement reference for network analyzer error-correction. This note covers methods for specifying these standards and describes the procedures for their use with the HP 8510 network analyzer.

The HP 8510 network analyzer system has the capability to make real-time error-corrected measurements of components and devices in a variety of transmission media. Fundamentally, all that is required is a set of known devices (standards) that can be defined physically or electrically and used to provide a reference for the physical interface of the test devices.

Hewlett-Packard supplies full calibration kits in 7mm, 3.5mm and Type N coaxial interfaces. The HP 8510 system can be calibrated in other interfaces such as other coaxial types, waveguide and microstrip, given good quality standards that can be defined.

The HP 8510's built-in flexibility for calibration kit definition allows the user to derive a precise set of definitions for a particular set of calibration standards from precise physical measurements. For example, the characteristic impedance of a matched impedance airline can be defined from its actual physical dimensions (diameter of outer and inner conductors) and electrical characteristics (skin depth). Although the airline is designed to provide perfect signal

transmission at the connection interface, the dimensions of individual airlines will vary somewhat — resulting in some reflection due to the change in impedance between the test port and the airline. By defining the actual impedance of the airline, the resultant reflection is characterized and can be removed through measurement calibration.

The scope of this product note includes a general description of the capabilities of the HP 8510 to accept new cal kit descriptions via the MODIFY CAL KIT function found in the HP 8510 CAL menu. It does not, however, describe how to design a set of physical standards. The selection and fabrication of appropriate calibration standards is as varied as the transmission media of the particular application and is beyond the scope of this note.

Table of Contents

- Introduction 2
- Measurement Errors 2
- Measurement Calibration 3
- Calibration Kit 3
- Standard Definition 4
- Class Assignment 4
- Modification Procedure 4
- Select Standards 4
- Define Standards 5
- Standard Number 6
- Standard Type 6
- C_0, C_1, C_2 and C_3 6
- Short Circuit Inductance
- L_0, L_1, L_2 and L_3 7
- Fixed or Sliding 7
- Terminal Impedance 7
- Offset Delay 7
- Offset Z_0 8
- Offset Loss 8
- Lower/Minimum Frequency .. 8
- Upper/Maximum Frequency .. 9
- Coax or Waveguide 9
- Standard Labels 9
- Assign Classes 9
- Standard Classes 9
- S_{11} A,B,C and S_{22} A,B,C 10
- Forward Transmission
- Match/Thru 10
- Reverse Transmission
- Match/Thru 10
- Isolation 10
- Frequency Response 10
- TRL Thru 10
- TRL Reflect 10
- TRL Line 10
- Adapter 10
- Standard Class Labels 10
- TRL Options 11
- Calibration Kit Label 11
- Enter Standards/Classes 11
- Verify Performance 11
- User Modified Cal Kits and HP 8510A
- Specifications 11
- Modification Examples 12
- Modeling a Thru Adapter 12
- Modeling an Arbitrary Impedance 12
- Appendix A Calibration Kit Entry Procedure 12
- Appendix B Dimensional Considerations In Coaxial Connectors 13

Introduction

This product note covers measurement calibration requirements for the HP 8510B network analyzer. All of the capabilities described in this note also apply to the HP 8510A with the following exceptions: Response & Isolation calibration; Short circuit inductance; class assignments for forward/reverse isolation, TRL Thru, Reflect, Line and Options; and Adapter Removal.

Measurement Errors

Measurement errors in network analysis can be separated into two categories: random and systematic errors. Both random and systematic errors are vector quantities. Random errors are non-repeatable measurement variations and are usually unpredictable. Systematic errors are repeatable measurement variations in the test setup.

Systematic errors include mismatch and leakage signals in the test setup, isolation characteristics between the reference and test signal paths, and

system frequency response. In most microwave measurements, systematic errors are the most significant source of measurement uncertainty. The source of these errors can be attributed to the signal separation scheme used.

The systematic errors present in an S-parameter measurement can be modeled with a signal flowgraph. The flowgraph model, which is used for error correction in the HP 8510 for the errors associated with measuring the S-parameters of a two port device, is shown in the figure below.

The six systematic errors in the forward direction are directivity, source match, reflection tracking, load match, transmission tracking and isolation. The reverse error model is a mirror image, giving a total of 12 errors for two-port measurements. The process of removing these systematic errors from the network analyzer S-parameter measurement is called measurement calibration.

- E_{DF}, E_{DR} —Directivity
- E_{SF}, E_{SR} —Source Match
- E_{RF}, E_{RR} —Refl. Tracking
- E_{LF}, E_{LR} —Load Match
- E_{TF}, E_{TR} —Trans. Tracking
- E_{XF}, E_{XR} —Isolation

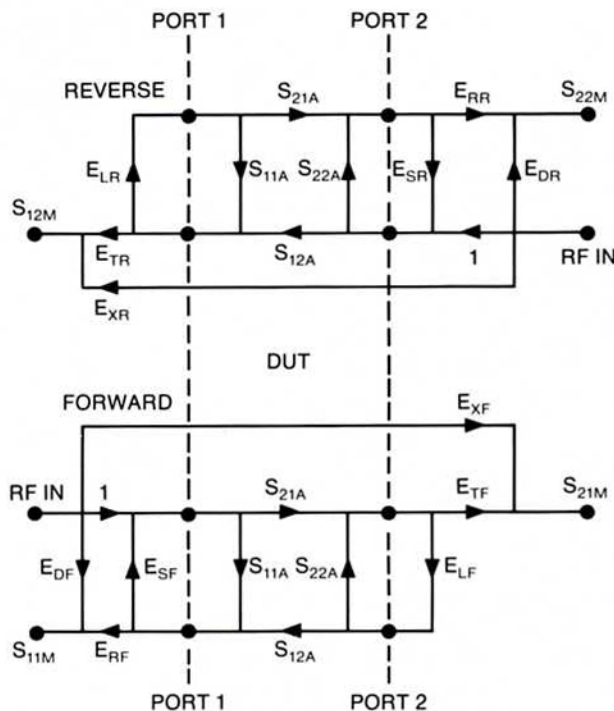

Figure 1. HP 8510 Full 2-Port Error Model

Measurement Calibration

A more complete definition of measurement calibration using the HP 8510, and a description of the error models is included in the HP 8510 Operating and Programming manual. The basic ideas are summarized here.

A measurement calibration is a process which mathematically derives the error model for the HP 8510. This error model is an array of vector coefficients used to establish a fixed reference plane of zero phase shift, zero magnitude and known impedance. The array coefficients are computed by measuring a set of "known" devices connected at a fixed point and solving as the vector difference between the modeled and measured response.

The full 2-port error model shown in figure 1 is an example of only one of the measurement calibrations available with the HP 8510. The measurement calibration process for the HP 8510 must be one of seven types; RESPONSE, RESPONSE & ISOLATION, S_{11} 1-PORT, S_{22} 1-PORT, ONE PATH 2-PORT, FULL 2-PORT, and TRL 2-PORT. Each of these calibration types solves for a different set of the systematic measurement errors. A RESPONSE calibration solves for the systematic error term for reflection or transmission tracking depending on the S-parameter which is activated on the HP 8510 at the time. RESPONSE & ISOLATION adds correction for crosstalk to a simple RESPONSE calibration. An S_{11} 1-PORT calibration solves for the forward error terms, directivity, source match and reflection tracking. Likewise, the S_{22} 1-PORT calibration solves for the same error terms in the reverse direction. A ONE PATH 2-PORT calibration solves for all the forward error terms. FULL 2-PORT and TRL 2-PORT calibrations include both forward and reverse error terms.

The type of measurement calibration selected by the user depends on the device to be measured (ie. 1-port or 2-port device) and the extent of accuracy enhancement desired. Further, a combination of calibrations can be used in the measurement of a particular device.

The accuracy of subsequent test device measurements is dependent on the accuracy of the test equipment, how well the "known" devices are modeled and the exactness of the error correction model.

Calibration Kit

A calibration kit is a set of physical devices called standards. Each standard has a precisely known or predictable magnitude and phase response as a function of frequency. In order for the HP 8510 to use the standards of a calibration kit, the response of each standard must be mathematically defined and then organized into standard classes which correspond to the error models used by the HP 8510.

HP currently supplies calibration kits with 7mm (HP 85050B/C/D), 3.5mm (HP 85052B/D) and N type (HP 85054B) coaxial connectors. To be able to use a particular calibration kit, the known characteristics from each standard in the kit must be entered into the HP 8510 nonvolatile memory. The Operating and Service manuals for each of the HP calibration kits contain the physical characteristics for each standard in the kit and mathematical definitions in the format required by the HP 8510.

Waveguide calibration using the HP 8510 is possible although HP does not presently supply the waveguide standards for all frequency bands. Calibration in microstrip and other non-coaxial media is described in HP Product Note 8510-8.

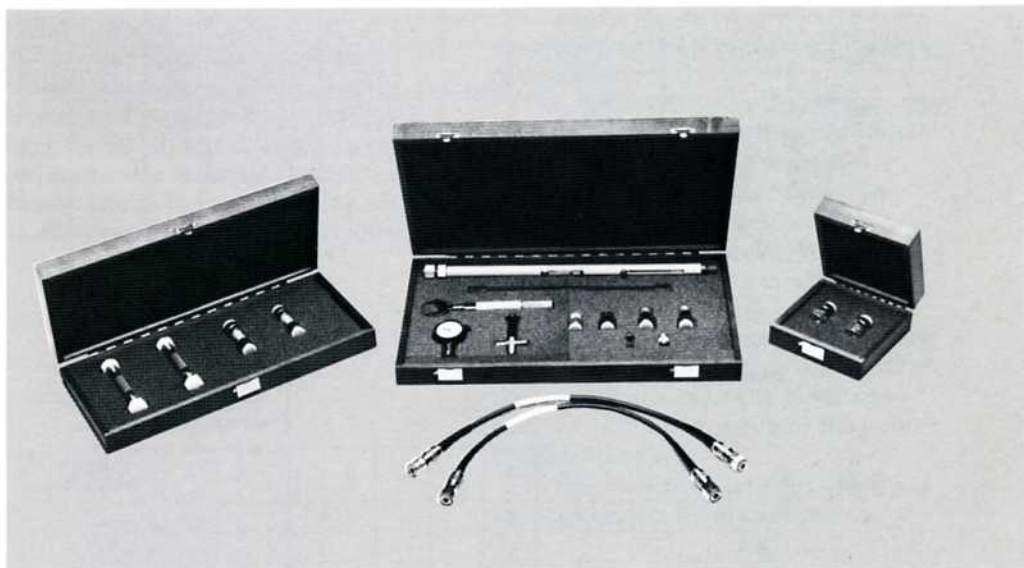

Standard Definition

Standard Definition is the process of mathematically modeling the electrical characteristics (delay, attenuation and impedance) of each calibration standard. These electrical characteristics can be mathematically derived from the physical dimensions and material of each calibration standards or from its actual measured response. A Standard Definition Table (see Table 1) lists the parameters that are used by the HP 8510 to specify the mathematical model.

Class Assignment

Class Assignment is the process of organizing calibration standards into a format which is compatible with the error models used in measurement calibration. A class or group of classes correspond to the seven calibration types used in the HP 8510. The 17 available classes are identified later in this note (see Assign Classes).

Modification Procedure

Calibration kit modification provides the capability to adapt to measurement calibrations in other connector types or to generate more precise error models from existing kits. Provided the appropriate standards are available, cal kit modification can be used to establish a reference plane in the same transmission media as the test devices and at a specified point, generally the point of device connection/insertion. After calibration, the resultant measurement system, including any adapters which would reduce system directivity, is fully corrected and the systematic measurement errors are mathematically removed. Additionally, the modification function allows the user to input more precise physical definitions for the standards in a given cal kit.

The process to modify or create a cal kit consists of the following steps.

1. Select Standards
2. Define Standards
3. Assign Classes
4. Enter Standards/Classes
5. Verify Performance

To further illustrate, an example waveguide calibration kit is developed as the general descriptions in MODIFY CAL KIT process are presented.

Select Standards

Determine what standards are necessary for calibration and are available in the transmission media of the test devices.

Calibration standards are chosen based on the following criteria.

- A well defined response which is mechanically repeatable and stable over typical ambient temperatures and conditions. The most common coaxial standards are zero-electrical-length short, shielded open and matched load terminations which ideally have fixed magnitude and broadband phase response. Since waveguide open circuits are generally not modelable, the types of standards typically used for waveguide calibration are a pair of offset shorts and a fixed or sliding load.

Table 1. Standard Definitions Table

STANDARD		C0 x10 ⁻¹¹ F	C1 x10 ⁻⁷ F/Hz	C2 x10 ⁻² F/Hz ²	C3 x10 ⁻⁴ F/Hz ³	FIXED OR SLIDING	TERMINAL IMPEDANCE Z ₀	OFFSET			FREQUENCY (GHz)		COAX or WAVEGUIDE	STND LABEL
NO.	TYPE	L0 x10 ⁻¹² H	L1 x10 ⁻⁷ H/Hz	L2 x10 ⁻¹² H/Hz ²	L3 x10 ⁻¹² H/Hz ³			DELAY pT	Z ₀ Ω	LOSS G(1/2)	MIN	MAX		
1	SHORT						0.0309	1	0	9.987	10.974	W/G	P SHORT 1	
2	SHORT						32.9925	1	0	9.987	10.974	W/G	P SHORT 2	
3	LOAD					FIXED	0	1	0	9.987	10.974	W/G	P LOAD	
4	THRU						0	1	0	9.987	10.974	W/G	P THRU	

Table 2. Standard Class Assignments

STANDARD CLASS ASSIGNMENTS		CALIBRATION KIT <u>WR-62</u>							STANDARD CLASS LABEL
		TAPE FILE NUMBER _____							
		A	B	C	D	E	F	G	
S ₁₁ A		1							P SHORT 1
S ₁₁ B		2							P SHORT 2
S ₁₁ C		3							P LOAD
S ₂₂ A		1							P SHORT 1
S ₂₂ B		2							P SHORT 2
S ₂₂ C		3							P LOAD
Forward Transmission		4							THRU
Reverse Transmission		4							THRU
Forward Match		4							THRU
Reverse Match		4							THRU
Forward Isolation ¹									
Reverse Isolation									
Frequency Response		1	2	4					RESPONSE
TRL Thru									
TRL Reflect									
TRL Line									
Adapter									

1. Forward Isolation Standard is also used for Isolation part of Response and Isolation calibration.

- An independent frequency response. To fully calibrate each test port (that is to provide the standards necessary for S_{11} or S_{22} 1-PORT calibration), three standards are required that exhibit distinct phase and/or magnitude at each particular frequency within the calibration band. For example: in coax, a zero-length short and a perfect shielded open exhibit 180 degree phase separation while a matched load will provide 40 to 50 dB magnitude separation from both the short and the open. In waveguide, a pair of offset shorts of correct length provide phase separation.
- Broadband frequency coverage. In broadband applications, it is often difficult to find standards that exhibit a known, suitable response over the entire band. A set of frequency-banded standards of the same type can be selected in order to characterize the full measurement band.
- The TRL 2-PORT calibration requires only a single precision impedance standard – a transmission line. An unknown high reflection device and a thru connection are sufficient to complete this technique.

Define Standards

A glossary of standard definition parameters used with the HP 8510 is included in this section. Each parameter is described and appropriate conversions are listed for implementation with the HP 8510. To illustrate, a calibration kit for WR-62 rectangular waveguide (operating frequency range 12.4 to 18.0 GHz) will be defined as shown in Table 1. Subsequent sections will continue to develop this waveguide example.

The mathematical models are developed for each standard in accordance with the standard definition parameters provided by the HP 8510. These standard definition parameters are shown below in Figure 2.

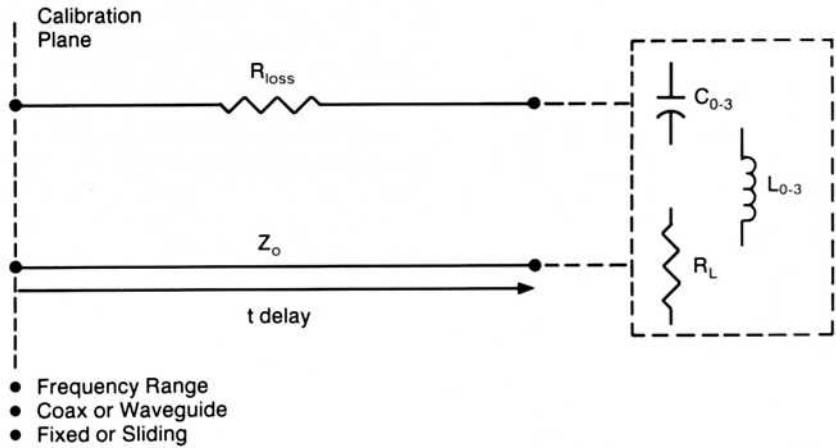

Model for Reflection Standard
(Short, Open, Load or Arbitrary Impedance)

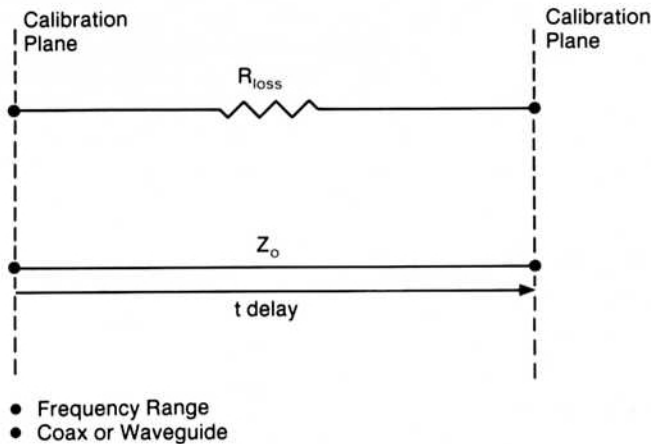

Model for Transmission Standard
(Thru)

Figure 2. Standard Definition Models

Each standard is described using the Standard Definition Table in accordance with the 1 or 2 port model. The Standard Definition Table for a waveguide calibration kit is shown in Table 1. Each standard type (short, open, load, thru and arbitrary impedance) may be defined by the parameters as specified below.

- Standard number and standard type
- Fringing capacitance of an open, or inductance of a short, specified by a third order polynomial
- Load/arbitrary impedance, which is specified as fixed or sliding
- Terminal Resistance of an arbitrary impedance
- Offsets which are specified by delay, Z_0 , R_{loss}
- Frequency range
- Connector type: coaxial or waveguide
- Label (up to 10 alphanumeric characters)

Standard Number

A calibration kit may contain up to 21 standards (See Table 1). The required number of standards will depend on frequency coverage and whether thru adapters are needed for sexed connectors.

For the WR-62 waveguide example, four standards will be sufficient to perform the FULL 2-PORT calibration. Three reflection standards are required, and one transmission standard (a thru) will be sufficient to complete this calibration kit.

Standard Type

A standard type must be classified as a "short", "open", "load", "thru" or "arbitrary impedance". The associated models for reflection standards (short, open, load and arbitrary impedance) and transmission standards (thru) are shown in Figure 1.

For the WR-62 waveguide calibration kit, the 4 standards are a $1/8\lambda$ & $3/8\lambda$ offset short, a fixed matched load and a thru. Standard types are entered into the Standard Definition Table under STANDARD NUMBERS 1 through 4 as short, short, load and thru respectively.

Open Circuit Capacitance:

C_0 , C_1 , C_2 and C_3

If the standard type selected is an 'open', the C_0 through C_3 coefficients are specified and then used to mathematically model the phase shift caused by fringing capacitance as a function of frequency.

As a reflection standard, an 'open' offers the advantage of broadband frequency coverage, while offset shorts cannot be used over more than an octave. The reflection coefficient ($\Gamma = \rho e^{-j\theta}$) of a perfect zero-length-open is 1 at 0° for all frequencies. At microwave frequencies however, the magnitude and phase of an 'open' are affected by the radiation loss and capacitive "fringing" fields, respectively. In coaxial transmission media, shielding techniques are effective in reducing the radiation loss. The magnitude (ρ) of an 'open' is assigned to be 1 (zero radiation loss) for all frequencies when using the HP 8510 Standard Type 'open'.

It is not possible to remove fringing capacitance, but the resultant phase shift can be modeled as a function of frequency using C_0 through C_3 ($C_0 + C_1 \times F + C_2 \times F^2 + C_3 \times F^3$, with units of F(Hz), C_0 (fF), C_1 (10^{-27} F/Hz), C_2 (10^{-36} F/Hz²) and C_3 (10^{-45} F/Hz³), which are the coefficients for a cubic polynomial that best fits the actual capacitance of the 'open'.

A number of methods can be used to determine the fringing capacitance of an 'open'. Three techniques, described here, involve a calibrated reflection coefficient measurement of an open standard and subsequent calculation of the effective capacitance. The value of fringing capacitance can be calculated from the measured phase or reactance as a function of frequency as follows.

$$C_{\text{eff}} = \frac{\tan(\frac{\Delta\theta}{2})}{2\pi f Z_0} = \frac{1}{2\pi f X}$$

- C_{eff} — effective capacitance
- $\Delta\theta$ — measured phase shift
- f — measurement frequency
- Z_0 — characteristic impedance
- X — measured reactance

This capacitance can then be modeled by choosing coefficients to best fit the measured response when measured by either method 3 or 4 below.

1. Fully calibrated 1 Port — Establish a calibrated reference plane using three independent standards (i.e. 2 sets of banded offset shorts and load). Measure the phase response of the open and solve for the capacitance function.
2. TRL 2-PORT — When transmission lines standards are available, this method can be used for a complete 2-port calibration. With error-correction applied the capacitance of the open can be measured directly.
3. Gating — Use time domain gating to correct the measured response of the open by isolating the reflection due to the open from the source match reflection and signal path leakage (directivity). Figure 3 shows the time domain response of the open at the end of an airline. Measure the gated phase response of the open at the end of an air-line and again solve for the capacitance function.

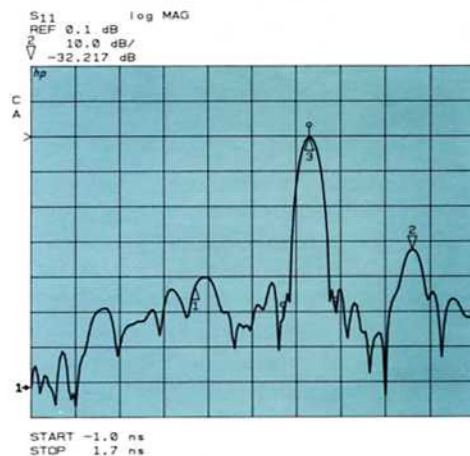

Figure 3. Time Domain Response of Open at the End of an Airline

Note

In some cases (when the phase response is linear with respect to frequency) the response of an open can be modeled as an equivalent 'incremental' length.

$$\Delta\phi(\text{radians}) = \frac{2\pi f (\Delta\text{length})}{c}$$

This method will serve as a first order approximation only, but can be useful when data or standards for the above modeling techniques are not available.

For the waveguide example, this parameter is not addressed since opens cannot be made valid standards in waveguide, due to the excessive radiation loss and indeterminant phase.

Short Circuit Inductance

L_0, L_1, L_2 and L_3

If the standard type selected is a 'short,' the L_0 through L_3 coefficients are specified to model the phase shift caused by the standard's residual inductance as a function of frequency. The reflection coefficient of an ideal zero-length short is 1 at 180° at all frequencies. At microwave frequencies, however, the residual inductance can produce additional phase shift. When the inductance is known and repeatable, this phase shift can be accounted for during the calibration.

The inductance as a function of frequency can be modeled by specifying the coefficients of a third-order polynomial ($L_0 + L_1 \times F + L_2 \times F^2 + L_3 \times F^3$, with units of $F(\text{Hz})$, $L_0(\text{nH})$, $L_1(10^{-24}\text{H}/\text{Hz})$, $L_2(10^{-33}\text{H}/\text{Hz}^2)$ and $L_3(10^{-42}\text{H}/\text{Hz}^3)$).

For the waveguide example, the inductance of the offset short circuits is negligible. L_0 through L_3 are set equal to zero.

Fixed or Sliding

If the standard type is specified to be a load or an arbitrary impedance, then it must be specified as fixed or sliding. Selection of "sliding" provides a sub-menu in the calibration sequence for multiple slide positions and measurement. This enables calculation of the directivity vector by mathematically eliminating the response due to a non-ideal terminal impedance. A further explanation of this technique is found in the Measurement Calibration section in the HP 8510 Operating and Programming manual.

The load standard #4 in the WR-62 waveguide calibration kit is defined as a fixed load. Enter FIXED in the table.

Terminal Impedance

Terminal impedance is only specified for "arbitrary impedance" standards. This allows definition of only the real part of the terminating impedance in ohms. Selection as the Standard Type 'short,' 'open' or 'load' automatically assigns the terminal impedance to be 0, ∞ or 50 ohms respectively.

The WR-62 waveguide calibration kit example does not contain an arbitrary impedance standard.

Offset Delay

If the standard has electrical length (relative to the calibration plane), a standard is specified to have an offset delay. Offset delay is entered as the one-way travel time through an offset that can be obtained from the physical length using propagation velocity of light in free space and the appropriate permittivity constant. The effective propagation velocity equals $c\sqrt{\epsilon_r}$. See Appendix B for a further description of physical offset lengths for sexed connector types.

$$\text{Delay (seconds)} = \frac{\ell\sqrt{\epsilon_r}}{c}$$

ℓ = precise measurement of offset length in meters

ϵ_r = relative permittivity
(= 1.000649 for coaxial airline or air-filled waveguide in standard lab conditions)

$c = 2.997925 \times 10^8$ m/s

In coaxial transmission line, group delay is constant over frequency. In waveguide however, group velocity does vary with frequency due to dispersion as a function of the cut-off frequency.

The convention for definition of offset delay in waveguide requires entry of the delay assuming no dispersion. For waveguide transmission line, the HP 8510 calculates the effects of dispersion as a function of frequency as follows:

$$\text{Actual Delay} = \frac{\text{Linear Delay}}{\sqrt{1 - (f_{co}/f)^2}}$$

f_{co} = lower cutoff frequency
 f = measurement frequency

Note

To assure accurate definition of offset delay, a physical measurement of offset length is recommended.

The actual length of offset shorts will vary by manufacturer. For example, the physical length of an $1/8 \lambda$ offset depends on the center frequency chosen. In waveguide this may correspond to the arithmetic or geometric mean frequency. The arithmetic mean frequency is simply $(F_1 + F_2)/2$, where F_1 and F_2 are minimum and maximum operating frequencies of the waveguide type. The geometric mean frequency is calculated as the square root of $F_1 \times F_2$. The corresponding (λ_g) is then calculated from the mean frequency and the cut-off frequency of the waveguide type. Fractional wavelength offsets are then specified with respect to this wavelength.

For the WR-62 calibration kit, offset delay is zero for the "thru" (std #4) and the "load" (std #3). To find the offset delay of the $1/8 \lambda$ and $3/8 \lambda$ offset shorts, precise offset length measurements are necessary. For the $1/8 \lambda$ offset short, $l = 3.24605$ mm, $\epsilon_r = 1.000649$, $c = 2.997925 \times 10^8$ m/s.

$$\text{Delay} = \frac{(3.24605 \times 10^{-3} \text{ m}) (\sqrt{1.000649})}{2.997925 \times 10^8 \text{ m/s}} = 10.8309 \text{ pS}$$

For the $3/8 \lambda$ offset short, $l = 9.7377$ mm, $\epsilon_r = 1.000649$, $c = 2.997925 \times 10^8$ m/s.

$$\text{Delay} = \frac{(9.7377 \times 10^{-3} \text{ m}) (\sqrt{1.000649})}{2.997925 \times 10^8 \text{ m/s}} = 32.4925 \text{ pS}$$

Offset Z_0

Offset Z_0 is the characteristic impedance within the offset length. For coaxial type offset standards, specify the real (resistive) part of the characteristic impedance in the transmission media. The characteristic impedance in lossless coaxial transmission media can be calculated from its physical geometry as follows.

$$Z_0 = \frac{1}{2\pi} \sqrt{\frac{\mu}{\epsilon}} \ln\left(\frac{D}{d}\right)$$

$$= 59.9585 \sqrt{\frac{\mu_r}{\epsilon_r}} \ln\left(\frac{D}{d}\right)$$

μ_r = relative permeability constant of the medium (equal to 1.0 in air)

ϵ_r = relative permittivity constant of the medium (equal to 1.000649 in air)

D = inside diameter of outer conductor

d = outside diameter of inner conductor

The HP 8510 requires that the characteristic impedance of waveguide transmission line is assigned to be equal to the SET Z_0 .

The characteristic impedance of other transmission media is not as easily determined through mechanical dimensions. Waveguide impedance, for example, varies as a function of frequency. In such cases, normalized impedance measurements are typically made. When calibrating in waveguide, the impedance of a 'matched' load is used as the impedance reference. The impedance of this load is matched that of the waveguide across frequency. Normalized impedance is achieved by entering SET Z_0 and OFFSET Z_0 to 1 ohm for each standard.

Offset Z_0 equal to system Z_0 (SET Z_0) is the assigned convention in the HP 8510 for matched waveguide impedance.

Offset Loss

Offset loss is used to model the magnitude loss due to skin effect of offset coaxial type standards only. The value of loss is entered into the standard definition table as Gigohms/second or ohms/nanosecond at 1 GHz.

The offset loss in Gigohms/second can be calculated from the measured loss at 1 GHz and the physical length of the particular standard by the following equation.

$$\text{Offset Loss} \left(\frac{\text{G}\Omega}{\text{s}} \right) \Big|_{1 \text{ GHz}} = \frac{\text{dB}_{\text{loss}} \Big|_{1 \text{ GHz}} c \sqrt{\epsilon_r} Z_0}{10 \log_{10}(e) l}$$

where:

$\text{dB}_{\text{loss}} \Big|_{1 \text{ GHz}}$ = measured insertion loss at 1 GHz

Z_0 = Offset Z_0

l = physical length of the offset

The HP 8510 calculates the skin loss as a function of frequency as follows:

$$\text{Offset Loss} \left(\frac{\text{G}\Omega}{\text{s}} \right) = \text{Offset Loss} \left(\frac{\text{G}\Omega}{\text{s}} \right) \Big|_{1 \text{ GHz}} \times \sqrt{f(\text{GHz})}$$

For all offset standards, including shorts or opens, enter the one way skin loss. The offset loss in waveguide should always be assigned zero ohms by the HP 8510.

Therefore, for the WR-62 waveguide standard definition table, offset loss of zero ohm/sec is entered for all four standards.

Lower/Minimum Frequency

Lower frequency defines the minimum frequency at which the standard is to be used for the purposes of calibration.

Note

When defining coaxial offset standards, it may be necessary to use banded offset shorts to specify a single standard class. The lower and upper frequency parameters should be used to indicate the frequency range of desired response. It should be noted that lower and upper frequency serve a dual purpose of separating banded standards which comprise a single class as well as defining the overall applicable frequency range over which a calibration kit may be used.

In waveguide, this must be its lower cut-off frequency of the principal mode of propagation. Waveguide cut-off frequencies can be found in most waveguide textbooks. The cutoff frequency of the fundamental mode of propagation (TE_{10}) in rectangular waveguide is defined as follows.

$$f = \frac{c}{2a}$$

$c = 2.997925 \times 10^{10}$ cm/sec.
a = inside width of waveguide, larger dimension in cm

As referenced in offset delay, the minimum frequency is used to compute the dispersion effects in waveguide.

For the WR-62 waveguide example, the lower cutoff frequency is calculated as follows.

$$f = \frac{c}{2a} = \frac{2.997925 \times 10^{10} \text{ cm/s}}{2 \times 1.58 \text{ cm}} = 9.487 \text{ GHz}$$

$c = 2.997925 \times 10^{10}$ cm/s
a = 1.58 cm

The lower cut-off frequency of 9.487 GHz is entered into the table for all four WR-62 waveguide standards.

Upper/Maximum Frequency

This specifies the maximum frequency at which the standard is valid. In broadband applications, a set of banded standards may be necessary to provide constant response. For example, coaxial offset standards (ie. $1/4 \lambda$ offset short) are generally specified over bandwidths of an octave or less. Bandwidth specification of standards, using minimum frequency and maximum frequency, enables the HP 8510 to characterize only the specified band during calibration. Further, a submenu for banded standards is enabled which requires the user to completely characterize the current measurement frequency range. In waveguide, this is the upper cutoff frequency for the waveguide class and mode of propagation. For the fundamental mode of propagation in rectangular waveguide the maximum upper cutoff frequency is twice the lower cutoff frequency and can be calculated as follows.

$$F(\text{upper}) = 2 \times F(\text{lower})$$

The upper frequency of a waveguide standard may also be specified as the maximum operating frequency as listed in a textbook.

The MAXIMUM FREQUENCY of the WR-62 waveguide cal kit is 18.974 GHz and is entered into the standard definition table for all four standards.

Coax or Waveguide

It is necessary to specify whether the standard selected is coaxial or waveguide. Coaxial transmission line has a linear phase response as follows.

$$\varnothing(\text{radians}) = \frac{2\pi l}{\lambda} = 2\pi f(\text{delay})$$

Waveguide transmission line exhibits dispersive phase response as follows.

$$\varnothing(\text{radians}) = \frac{2\pi l}{\lambda_g}$$

where

$$\lambda_g = \frac{\lambda}{\sqrt{1 - (\lambda/\lambda_{co})^2}}$$

Selection of WAVEGUIDE computes offset delay using the dispersive response, of rectangular waveguide only, as a function of frequency as

$$\text{Delay (seconds)} = \frac{\text{Linear Delay}}{\sqrt{1 - (f_{co}/f)^2}}$$

This emphasizes the importance of entering 'f_{co}' as the LOWER FREQUENCY.

Selection of COAXIAL assumes linear response of offset delay.

Note

Mathematical operations on measurements (and displayed data) after calibration are not corrected for dispersion.

Enter WAVEGUIDE into the standard definition table for all four standards.

Standard Labels

Labels are entered through the title menu and may contain up to 10 characters. Standard Labels are entered to facilitate menu driven calibration. Labels that describe and differentiate each standard should be used. This is especially true for multiple standards of the same type.

When sexed connector standards are labeled, male (M) or female (F), the designation refers to the test port connector sex — not the connector sex of the standard. Further, it is recommended that the label include information carried on the standard such as the serial number of the particular standard to avoid confusing multiple standards which are similar in appearance.

The labels for the four standards in the waveguide example are; #1-PSHORT1, #2-PSHORT2, #3-PLOAD, and #4-THRU.

Assign Classes

In the previous section, Define Standards, the characteristics of calibration standards were derived. Class assignment organizes these standards for computation of the various error models used in calibration. The HP 8510 requires a fixed number of standard classes to solve for the n terms used in the error models (n = 1, 3 or 12). That is, the number of calibration error terms required by the HP 8510 to characterize the measurement system (1 Port, 2-Port, etc.) equals the number of classes utilized.

Standard Classes

A single Standard Class is a standard or group of (up to 7) standards that comprise a single calibration step. The standards within a single class are assigned to locations A through G as listed on the Class Assignments Table. It is important to note that a class must be defined over the entire frequency range that a calibration is made, even though several separate standards may be required to cover the full measurement frequency range. In the measurement calibration process, the order of standard measurement within a given class is not important unless significant frequency overlap exists among the standards used. When two standards have overlapping frequency bands, the last standard to be measured will be used by the HP 8510. The order of standard measurement between different classes is not restricted, although the HP 8510 requires that all standards that will be used within a given class are measured before proceeding to the next class. Standards are organized into specified classes which are defined by a Standards Class Assignment table. See Table 2 for the class assignments table for the waveguide calibration kit.

S_{11} A,B,C and S_{22} A,B,C:

S_{11} A,B,C and S_{22} A,B,C correspond to the S_{11} and S_{22} reflection calibrations for port 1 and port 2 respectively. These 3 classes are used by the HP 8510 to solve for the systematic errors; directivity, source match, and reflection tracking. The three classes used by the 7mm cal kit are labeled 'short,' 'open,' and 'loads.' 'Loads' refers to a group of standards which is required to complete this standard class. A class may include a set of standards of which there is more than one acceptable selection or more than one standard required to calibrate the desired frequency range.

Table 2 contains the class assignment for the WR-62 waveguide cal kit. The $1/8\lambda$ offset short (Standard #1) is assigned to S_{11} A. The $3/8\lambda$ offset short (Standard #2) is assigned to S_{11} B. The matched load (Standard #3) is assigned to S_{11} C.

Forward Transmission Match and Thru

Forward Transmission (Match and Thru) classes correspond to the forward (port 1 to port 2) transmission and reflection measurement of the "delay/thru" standard in a FULL 2-PORT or ONE-PATH 2-PORT calibration. During measurement calibration the response of the "match" standard is used to find the systematic Load Match error term. Similarly the response of the thru standard is used to characterize transmission tracking.

The class assignments for the WR-62 waveguide cal kit are as follows. The thru (Standard #4) is assigned to both FORWARD TRANSMISSION and FORWARD MATCH.

Reverse Transmission Match and Thru

Reverse Transmission (Match and Thru) classes correspond to the reverse transmission and reflection measurement of the "delay/thru" standard. For S-parameter test sets, this is the port 2 to port 1 transmission path. For the reflection/transmission test sets, the device is reversed and is measured in the same manner using the forward transmission calibration.

The class assignments for the WR-62 waveguide cal kit are as follows. The thru (Standard #4) is assigned to both REVERSE TRANSMISSION and REVERSE MATCH.

Isolation

Isolation is simply the leakage from port 1 to port 2 internal to the test set.

To determine the leakage signals (crosstalk), each port should be terminated with matched loads while measuring S_{21} and S_{12} .

The class assignments for forward and reverse isolation are both loads (Standard #3).

Frequency Response

Frequency Response is a single class which corresponds to a one-term error correction that characterizes only the vector frequency response of the test configuration. Transmission calibration typically uses a 'thru' and reflection calibration typically uses either an 'open' or a 'short'.

Note

The Frequency Response calibration is not a simple frequency normalization. A normalized response is a mathematical comparison between measured data and stored data. The important difference is, that when a standard with non-zero phase, such as an offset short, is remeasured after calibration using Frequency Response, the actual phase offset will be displayed, but its normalized response would display zero phase offset (measured response minus stored response).

Therefore, the WR-62 waveguide calibration kit class assignment includes standard #1, standard #2 and Standard #4.

TRL Thru

TRL Thru corresponds to the measurement of the S-parameters of a zero-length or short thru connection between port 1 and port 2. The Thru, Reflect and Line classes are used exclusively for the three steps of the TRL 2-PORT calibration. Typically, a 'delay/thru' with zero (or very small) Offset Delay is specified as the TRL Thru standard.

TRL Reflect

TRL Reflect corresponds to the S_{11} and S_{22} measurement of a highly reflective 1-port device. The Reflect (typically an open or short circuit) must be the same for port 1 and 2. The reflection coefficient magnitude of the Reflect should be close to 1 but is not specified. The phase of the Reflection coefficient need only be approximately specified (within ± 90 degrees).

TRL Line

TRL Line corresponds to the measurement of the S-parameters of a short transmission line. The impedance of this line determines the reference impedance for the subsequent error-corrected measurements. The insertion phase of the Line need not be precisely defined but may not be the same as (nor a multiple of pi) the phase of the Thru.

Adapter

This class is used to specify the adapters used for the Adapter Removal process. The standard number of the adapter or adapters to be characterized is entered into the class assignment. Only an estimate of the adapter's Offset Delay is required (within ± 90 degrees). A simple way to estimate the Offset Delay of any adapter would be as follows. Perform a 1-port calibration (Response or S_{11} 1-PORT) and then connect the adapter to the test port. Terminate the adapter with a short circuit and then measure the Group Delay. If the short circuit is not an offset short, the adapter's Offset Delay is simply $1/2$ of the measured delay. If the short circuit is offset, its delay must be subtracted from the measured delay.

Each adapter is specified as a single delay/thru standard and up to seven standards numbers can be specified into the Adapter Class.

Standard Class Labels

Standard Class labels are entered to facilitate menu-driven calibration. A label can be any user-selected term which best describes the device or class of devices that the operator should connect. Predefined labels exist for each class. These labels are

S_{11A} , S_{11B} , S_{11C} , S_{22A} , S_{22B} , S_{22C} , FWD TRANS, FWD MATCH, REV TRANS, REV MATCH, RESPONSE, FWD ISOLATION, REV ISOLATION, THRU, REFLECT, LINE and ADAPTER.

The class labels for the WR-62 waveguide calibration kit are as follows; S_{11A} and S_{22A} — PSHORT1; S_{11B} and S_{22B} — PSHORT2; S_{11C} and S_{22C} — PLOAD; FWD TRANS, FWD MATCH, REV TRANS and REV MATCH — PTHRU; and RESPONSE — RESPONSE.

TRL Options

When performing a TRL 2-PORT calibration, certain options may be selected. CAL Z_0 is used to specify whether skin-effect-related impedance variation is to be used or not. Skin effect in lossy transmission line standards will cause a frequency-dependent variation in impedance. This variation can be compensated when the skin loss (Offset Loss) and the mechanically derived impedance (Offset Z_0) are specified and CAL Z_0 : SYSTEM Z_0 selected. CAL Z_0 : LINE Z_0 specifies that the impedance of the line is equal to the Offset Z_0 at all frequencies.

The phase reference can be specified by the Thru or Reflect during the TRL 2-PORT calibration. SET REF: THRU corresponds to a reference plane set by Thru standard (or the ratio of the physical lengths of the Thru and Line) and SET REF: REFLECT corresponds to the Reflect standard.

LOWBAND FREQUENCY is used to select the minimum frequency for coaxial TRL calibrations. Below this frequency (typically 2 to 3 GHz) S_{11} and S_{22} 1-PORT calibrations can be used. Unlike MINIMUM FREQUENCY, this frequency may be neglected during calibration. In that case the TRL standards would be used over the full frequency range. To achieve specified performance in a coaxial interface, TRL standards should only be used down to the low-band frequency. Note: The resultant calibration is a single cal set combining the TRL and conventional 1-PORT calibrations.

Calibration Kit Label

A calibration kit label is selected to describe the connector type of the devices to be measured. If a new label is not generated, the calibration kit label for the kit previously contained in that calibration kit register (CAL 1 or CAL 2) will remain. The predefined labels for the two calibration kit registers are:

Calibration Kit 1	Cal 1	HP 85050B
	7mm B.1	
Calibration Kit 2	Cal 2	HP 85052B
	3.5mm B.1	

Again, cal kit labels should be chosen to best describe the calibration devices. The "B.1" default suffix corresponds to the kit's mechanical revision (B) and mathematical revision (1).

Note

To prevent confusion, if any standard definitions in a calibration kit are modified but a new kit label is not entered, the default label will appear with the last character replaced by a "***". This is not the case if only a class is redefined without changing a standard definition.

The WR-62 waveguide calibration kit can be labeled simply — P BAND.

Enter Standards/Classes

The specifications for the Standard Definition Table and Standard Class Assignments Table can be entered into the HP 8510 through front panel menu-driven entry or under program control by an external controller. The procedure for entry of standard definitions, standard labels, class assignments, class labels and calibration kit label is described in Appendix A.

Note

DO NOT exit the calibration kit modification process without saving the calibration kit definitions in the appropriate register in the HP 8510. Failure to save the redefined calibration kit will result in not saving the new definitions and the original definitions for that register will remain. Once this process is completed, it is recommended that the new calibration kit should be saved on tape.

Verify Performance

Once a measurement calibration using a particular calibration kit has been generated, its performance should be checked before making device measurements. To check the accuracy that can be obtained using the new calibration kit, a device with a well defined frequency response (preferably unlike any of the standards used) should be measured. It is important to note that the verification device must not be one of the calibration standards. Calibrated measurement of one of the calibration standards is merely a measure of repeatability.

A performance check of waveguide calibration kits is often accomplished by measuring a zero length short or a short at the end of a straight section of waveguide. The measured response of this device on a polar display should be a dot at $1 \angle 180^\circ$. The deviation from the known is an indication of the accuracy.

To achieve a more complete verification of a particular measurement calibration, (including dynamic accuracy) accurately known verification standards with a diverse magnitude and phase response should be used. NBS traceable or HP standards are recommended to achieve verifiable measurement accuracy. Further, it is recommended that verification standards with known but different phase and magnitude response than any of the calibration standards be used to verify performance of the HP 8510.

User Modified Cal Kits and HP 8510 Specifications

As noted previously, the resultant accuracy of the HP 8510 when used with any calibration kit is dependent on how well its standards are defined and is verified through measurement of a device with traceable frequency response.

The published Measurement Specifications for the HP 8510 Network Analyzer system include calibration with HP Calibration Kits such as the HP 85050B. Measurement

calibrations made with user defined or modified calibration kits are not subject to the HP 8510 performance specifications although a procedure similar to the standard verification procedure may be used.

Modification Examples

Modeling A 'Thru' Adapter

The MODIFY CAL KIT function allows more precise definition of existing standards, such as the 'thru'. For example, when measuring devices with the same sex coaxial connectors, a set of 'thru' standards to adapt non-insertable devices on each end is needed. Various techniques are used to cancel the effects of the 'thru' adapters. However, using the modify cal kit function to make a precise definition of the 'thru' enables the HP 8510 to mathematically "remove" the attenuation and phase shift due to the 'thru' adapter. To model correctly a 'thru' of fixed length, accurate gauging (see OFFSET DELAY) and a precise measurement of skin-loss attenuation (see OFFSET LOSS) are required. The characteristic impedance of the 'thru' can be found from the inner and outer conductor diameters and the permittivity of the dielectric (see OFFSET Z_0).

Modeling An 'Arbitrary Impedance' Standard

The 'arbitrary impedance' standard allows the user to model the actual response of any one port passive device for use as a calibration standard. As previously stated, the calibration is mathematically derived by comparing the measured response to the known response which is modeled through the standard definition table. However, when the known response of a one-port standard is not purely reflective (short/open) or perfectly matched (load) but the response has a fixed real impedance, then it can be modeled as an arbitrary impedance.

A 'load' type standard has an assigned terminal impedance equal to the system Z_0 . If a given load has an impedance which is other than the

system Z_0 , the load itself will produce a systematic error in solving for the directivity of the measurement system during calibration. A portion of the incident signal will be reflected from the mismatched load and sum together with the actual leakage between the reference and test channels within the measurement system. However, since this reflection is systematic and predicatable (provided the terminating impedance is known) it may be mathematically removed. The calibration can be improved if the standard's terminal impedance is entered into the definition table as an 'arbitrary impedance' rather than as a 'load'.

A procedure similar to that used for measurement of open circuit capacitance (see method #3) could be used to make a calibrated measurement of the terminal impedance.

Appendix A Calibration Kit Entry Procedure

Calibration Kit specifications can be entered into the HP 8510 using the HP 8510 tape drive, a disc drive connected to the system bus, by front panel entry or through program control by an external controller.

Disc/Tape Procedure

This is an important feature since the HP 8510 can internally store only two calibration kits at one time while multiple calibration kits can be stored on a single tape or disc.

Below is the generic procedure to load or store calibration kits from and to the tape drive or disc interface.

To Load Calibration Kits from a Tape or Disc into the HP 8510

1. Insert the calibration data tape into the HP 8510 network analyzer (or connect compatible disc drive to system bus).
2. Press the DISC/TAPE key; select STORAGE IS: TAPE or DISC; then press the following CRT-displayed softkeys:

LOAD

CAL KIT 1-2

CAL KIT 1 or CAL KIT 2 (This selection determines which of the HP 8510 non-volatile registers that the calibration kit will be loaded.)

FILE #__ or FILE NAME.

3. To verify that the correct calibration kit was loaded into the instrument, press the CAL key. If properly loaded, the calibration kit label will be shown under "CAL 1" or "CAL 2" on the CRT display.

To Store Calibration Kits from the HP 8510 onto a Tape or Disc

1. Insert an initialized calibration data tape into the HP 8510 network analyzer or connect compatible disc drive to the system bus.
2. Press the DISC/TAPE key; select STORAGE IS: DISC or TAPE; then press the following CRT displayed softkeys:

STORE

CAL KIT 1-2

CAL KIT 1 or CAL KIT 2 (This selection determines which of the HP 8510 non-volatile calibration kit registers is to be stored.)

FILE #__ or FILE NAME.

3. Examine Directory to verify that file has been stored. This completes the sequence to store a calibration kit onto the tape or disc.

To generate a new cal kit or modify an existing one, either front panel or program controlled entry can be used.

In this guide, procedures have been given to define standards and assign classes. This section will list the steps required for front panel entry of the standards and appropriate labels.

Front Panel Procedure:

(P-Band Waveguide Example)

1. Prior to modifying or generating a cal kit, store one or both of the cal kits in the HP 8510's non-volatile memory to a tape or disc file.
2. Select CAL menu, MORE.
3. Prepare to modify cal kit 2: press MODIFY 2.
4. To define a standard: press DEFINE STANDARD.
5. Enable standard no. 1 to be modified: press 1, X1.
6. Select standard type: SHORT.
7. Specify an offset: SPECIFY OFFSETS.

8. Enter the delay from Table 1: OFFSET DELAY, 0.0108309, ns.

9. Enter the loss from Table 1: OFFSET LOSS, 0, X1.

10. Enter the Z_0 from Table 1: OFFSET Z_0 , 50, X1.

11. Enter the lower cutoff frequency: MINIMUM FREQUENCY, 9.487 GHz.

12. Enter the upper frequency: MAXIMUM FREQUENCY, 18.97 GHz.

13. Select WAVEGUIDE.

14. Prepare to label the new standard: PRIOR MENU, LABEL STANDARD, ERASE TITLE.

15. Enter PSHORT 1 by using the knob, SELECT LETTER soft key and SPACE soft key.

16. Complete the title entry by pressing TITLE DONE.

17. Complete the standard modification by pressing STANDARD DONE (DEFINED).

Standard #1 has now been defined for a $1/8 \lambda$ P-band waveguide offset short. To define the remaining standards, refer to Table 1 and repeat steps 4 - 17. To define standard #3, a matched load, specify 'fixed'.

The front panel procedure to implement the class assignments of Table 2 for the P-band waveguide cal kit are as follows:

1. Prepare to specify a class: SPECIFY CLASS.

2. Select standard class S_{11A} .

3. Inform the HP 8510A to use standard no. 1 for the S_{11A} class of calibration: 1, X1, CLASS DONE (SPECIFIED).

4. Change the class label for S_{11A} : LABEL CLASS, S_{11A} , ERASE TITLE.

5. Enter the label of PSHORT 1 by using the knob, the SELECT soft key and the SPACE soft key.

6. Complete the label entry procedure: TITLE DONE, LABEL DONE.

Follow a similar procedure to enter the remaining standard classes and labels shown below:

Finally, change the cal kit label as follows:

1. Press LABEL KIT.

2. Enter the title "P BAND".

3. Press TITLE DONE, KIT DONE (MODIFIED). The message 'CAL KIT SAVED' should appear.

This completes the entire cal kit modification for front panel entry. An example of programmed modification over the HP-IB bus through an external controller is shown in the Introduction To Programming section of the Operating and Service manual (Section III).

Appendix B Dimensional Considerations In Coaxial Connectors

This appendix describes dimensional considerations and required conventions used in determining the physical offset length of calibration standards in sexed coaxial connector families.

Precise measurement of the physical offset length is required to determine the OFFSET DELAY of a given calibration standard. The physical offset length of one and two port standards is as follows.

One port standard — Distance between 'calibration plane' and terminating impedance.

Two port standard — Distance between the Port 1 and Port 2 'calibration planes'.

The definition (location) of the 'calibration plane' in a calibration standard is dependent on the geometry and sex of the connector type. The 'calibration plane' is defined as a plane which is perpendicular to the axis of the conductor and either coincident with, or at a fixed distance from, the outer conductor mating surface. This mating surface is located at the contact points of the outer conductors of the test port and the calibration standard.

To illustrate this, consider the following connector type interfaces.

Standard Class	Standard No(s).	Class Label
S_{11B}	2	PSHORT 2
S_{11C}	3	PLOAD
S_{22A}	1	PSHORT 1
S_{22B}	2	PSHORT 2
S_{22C}	3	PLOAD
FWD TRANS	4	THRU
FWD MATCH	4	THRU
REV TRANS	4	THRU
REV MATCH	4	THRU
RESPONSE	1,2,4	RESPONSE

7mm Coaxial Connector Interface

The 'calibration plane' is located coincident to both the inner and outer conductor mating surfaces as shown. Unique to this connector type is the fact that the inner and outer conductor mating surfaces are located coincident as well as having hermaphroditic (sexless) connectors. In all other coaxial connector families this is not the case.

3.5mm Coaxial Connector Interface

The location of the 'calibration plane' in 3.5mm standards, both sexes, is located at the outer conductor mating surface as shown.

N-Type Coaxial Connector Interface

The location of the 'calibration plane' in N-type standards is the outer conductor mating surfaces as shown below.

Note

During measurement calibration using the HP 85054 N-type Calibration Kit, standard labels for the 'opens' and 'shorts' indicate both the standard type and the sex of the calibration test port. The sex (M or F) indicates the sex of the Test Port, NOT the sex of the standard.

The calibration plane in other coaxial types should be defined at one of the conductor interfaces to provide an easily verified reference for physical length measurements.

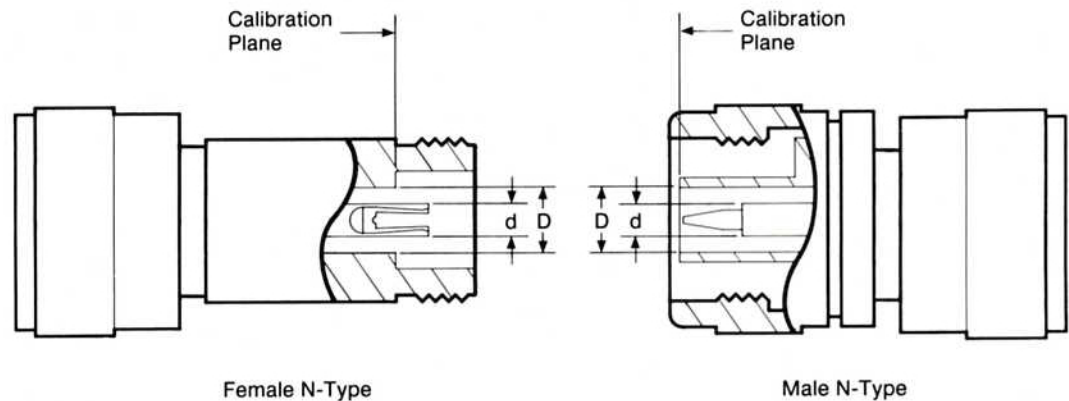
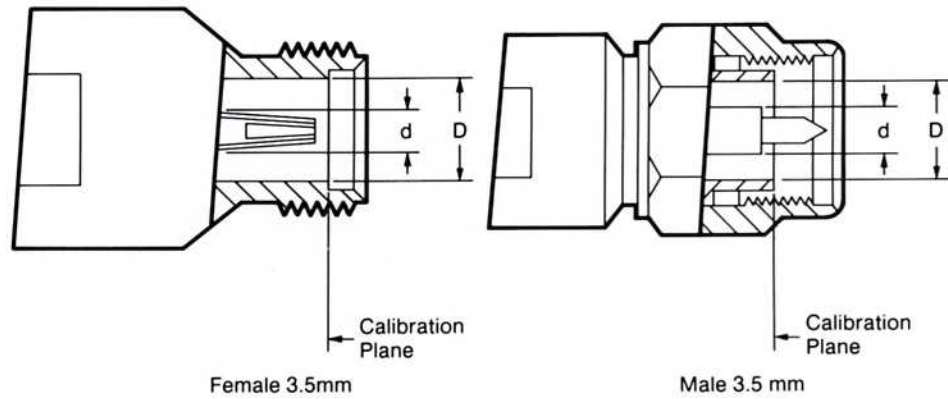
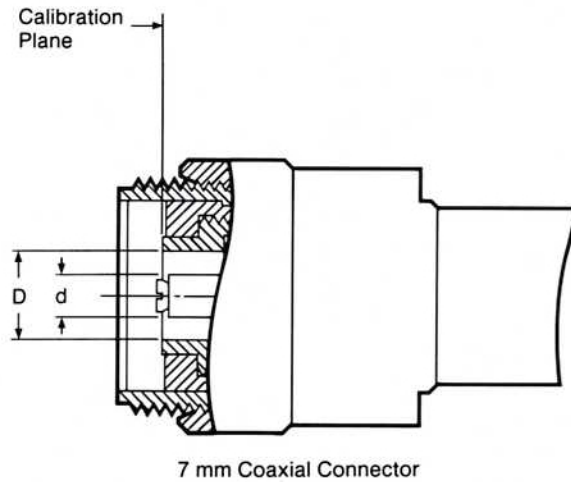

STANDARD		C0 x10 ⁻¹⁵ F	C1 x10 ⁻²⁷ F/Hz	C2 x10 ⁻³⁶ F/Hz ²	C3 x10 ⁻⁴⁵ F/Hz ³	FIXED OR SLIDING	TERMINAL IMPEDANCE Ω	OFFSET			FREQUENCY (GHz)		COAX or WAVEGUIDE	STND LABEL
NO.	TYPE	L0 x10 ⁻¹² H	L1 x10 ⁻²⁴ H/Hz	L2 x10 ⁻³³ H/Hz ²	L3 x10 ⁻⁴² H/Hz ³			DELAY ps	Z ₀ Ω	LOSS G(2)/s	MIN	MAX		
1														
2														
3														
4														
5														
6														
7														
8														
9														
10														
11														
12														
13														
14														
15														
16														
17														
18														
19														
20														
21														

STANDARD CLASS ASSIGNMENTS

	A	B	C	D	E	F	G	STANDARD CLASS LABEL
S ₁₁ A								
S ₁₁ B								
S ₁₁ C								
S ₂₂ A								
S ₂₂ B								
S ₂₂ C								
Forward Transmission								
Reverse Transmission								
Forward Match								
Reverse Match								
Forward Isolation ¹								
Reverse Isolation								
Frequency Response								
TRL Thru								
TRL Reflect								
TRL Line								
Adapter								

1. Forward Isolation Standard is also used for Isolation part of Response and Isolation calibration.

For more information, call your local HP sales office listed in your telephone directory or an HP regional office listed below for the location of your nearest sales office.

United States:

Hewlett-Packard Company
4 Choke Cherry Road
Rockville, MD 20850
(301) 670-4300

Hewlett-Packard Company
5201 Tollview Dr.
Rolling Meadows, IL 60008
(312) 255-9800

Hewlett-Packard Company
5161 Lankershim Blvd.
No. Hollywood, CA 91601
(818) 505-5600

Hewlett-Packard Company
2015 South Park Place
Atlanta, GA 30339
(404) 955-1500

Canada:

Hewlett-Packard Ltd.
6877 Goreway Drive
Mississauga, Ontario L4V1M8
(416) 678-9430

Japan:

Yokogawa-Hewlett-Packard Ltd.
29-21, Takaido-Higashi 3-chome
Suginami-ku, Tokyo 168
(03) 331-6111

Latin America:

Hewlett-Packard de Mexico,
Sp.A. de C.V.
Monte Pelvux No. 111
Lomas de Chapultepec
11000 Mexico D.F., Mexico
(905) 596-7933

Australia/New Zealand:

Hewlett-Packard Australia Ltd.
31-41 Joseph Street,
Blackburn, Victoria 3130
Melbourne, Australia
(03) 895-2895

Far East:

Hewlett-Packard Asia Ltd.
47/F China Resources Building
26 Harbour Road, Hong Kong
(5) 833-0833

Germany:

Hewlett-Packard GmbH
Vertriebszentrale Deutschland
Hewlett-Packard-Strasse
Postfach 1641
6380 Bad Homburg v.d.H.
Federal Republic of Germany
06172/400-0

France:

Hewlett-Packard France
Parc d'activité du Bois Briard
2, avenue du Lac
91040 Evry Cedex
01/60 77 83 83

United Kingdom:

Hewlett-Packard Ltd.
Enquiry Group
Customer Support Centre
Eskdale Road
Winnersh Triangle
Wokingham
Berkshire RG11 5DZ
0734/69 66 22

Italy:

Hewlett-Packard Italiana S.p.A.
Via G. di Vittorio, 9
20063 Cernusco Sul Naviglio (MI)
Milano
02/923691

Northern Europe:

Hewlett-Packard S.A.,
Van der Hooplaan 241
1185 LN Amstelveen
P.O. Box 999,
1180 AZ Amstelveen,
The Netherlands
(31) 20/547 9999

South East Europe:

Hewlett-Packard S.A.
World Trade Center
110, Avenue Louis-Casai
1215 Aeroport-Geneve
Switzerland
(41) 22/98 96 51

Or write to:

United States:

Hewlett-Packard Company
P.O. Box 10301,
Palo Alto, CA 94303-0890

Europe/Middle East/Africa:

Hewlett-Packard Company
Central Mailing Department,
P.O. Box 529
1180 AM Amstelveen,
The Netherlands

For all other areas:

Hewlett-Packard Company
Intercontinental Headquarters
3495 Deer Creek Rd.
Palo Alto, CA 94304
U.S.A.