

# Performing Two-Tone Measurements with the Agilent 8360 Series Synthesized Sweepers

Product Note 8360-4

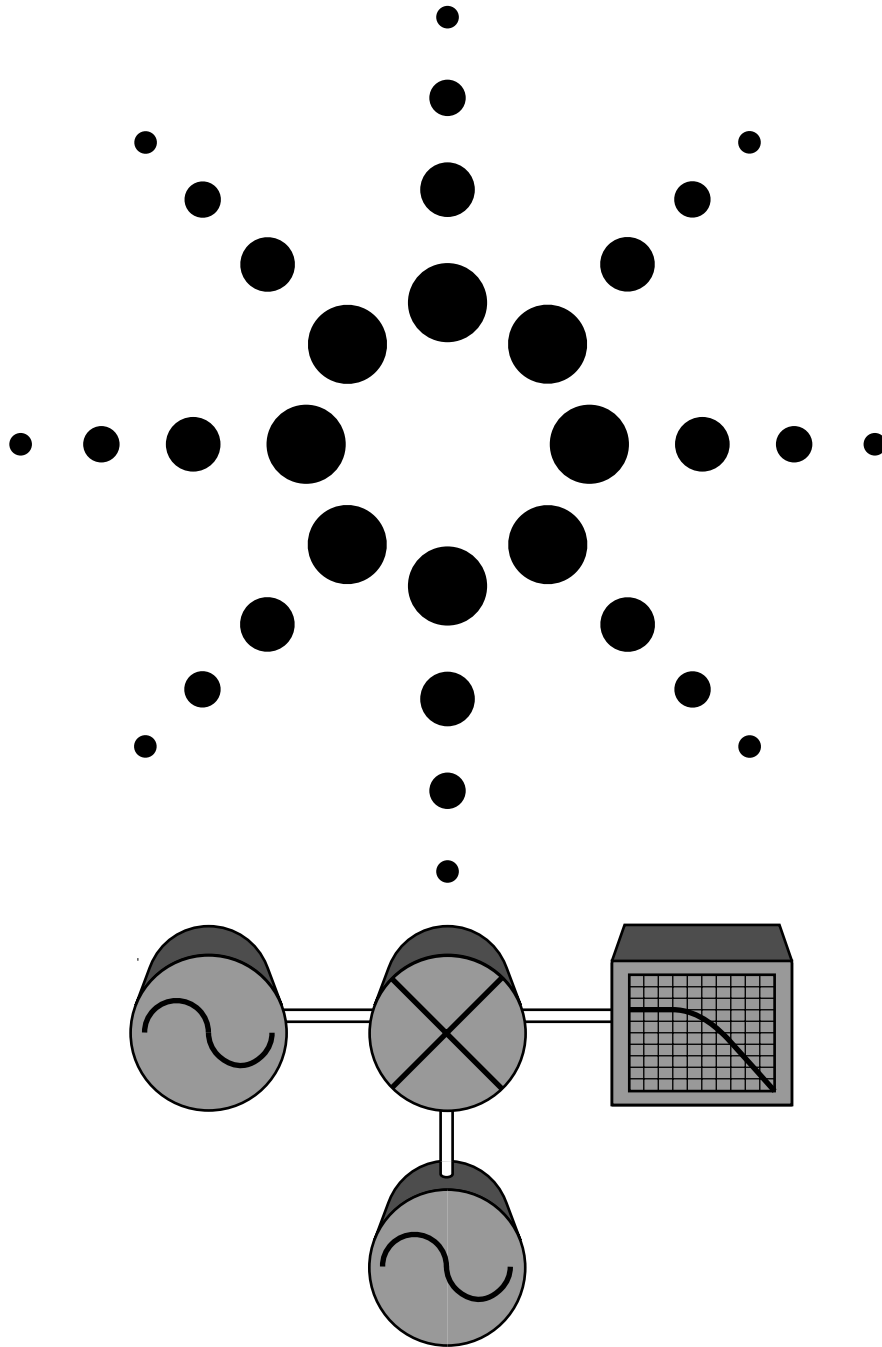

**Agilent Technologies**

Innovating the HP Way

## Introduction

Accurate fixed- and swept-frequency offset measurements can be achieved with an Agilent 8360 series synthesized sweeper two-tone measurement system. Designers and manufacturers of amplifiers, frequency translation devices such as mixers, and the systems that include these components, will benefit from the greater frequency accuracy and stability obtained during testing. The Agilent 8360 step-sweep feature offers synthesized frequency accuracy at each frequency point, providing more accurate device characterization than an analog ramp-sweep approach. This accuracy is further enhanced by providing one timebase reference for both sources, reducing instabilities from temperature or line voltage fluctuations.

This note illustrates how to use two Agilent 8360 synthesized sweepers<sup>1</sup> to obtain two tracking signals offset by a fixed frequency (fixed offset). The two-tone measurement setup described can also be used for swept intermediate frequency (swept offset) measurements with minor modifications. For both fixed- and swept-offset measurements, the Agilent 8360 synthesized sweepers can be operated in either ramp-sweep or step-sweep measurement modes; setup procedures are provided. In addition, the test configuration for a mixer conversion loss measurement is presented as a demonstration of a typical two-tone Agilent 8360 application. The mixer measurement example uses an Agilent 8757C<sup>1</sup> scalar analyzer, although an Agilent 8757E<sup>1</sup> may be substituted.

## Two-tone source configuration

Figure 1 illustrates the source interconnect for a two-tone measurement system. One Agilent 8360 synthesized sweeper is designated as the master and the other the slave. In this configuration, the master provides the frequency reference for both synthesized sweepers. In addition, the auxiliary interface connection provides the timing signals necessary to synchronize the sweeps of the two sources. To avoid synchronization problems, the slave should always be set up prior to the master.

When configuring a two-tone measurement with a network analyzer, oscilloscope or other display, only the master source should be connected to the display via the appropriate GPIB, stop sweep, blanking, and/or sweep ramp connectors on the synthesizer's rear panel. The interface to the display instrument should be configured as if the master is the only source in the system (see figure 2).

## Fixed-offset two-tone source

The following section presents step-by-step procedures for setting up a fixed-offset two-tone source. Fixed-offset sources are particularly useful for amplifier intermodulation distortion, mixer characterization and receiver front-end measurements.

To simplify execution of the source setup procedures, the keys to be selected are enclosed in brackets: front panel hardkeys are capitalized and the softkeys they access are in italics. Setups for both step-sweep and ramp-sweep measurements are provided in tables 1 and 2, respectively.

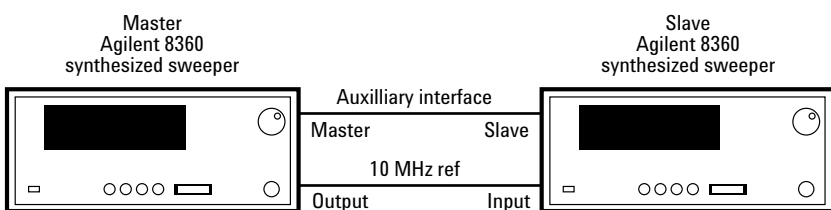

Figure 1. Basic two-tone measurement configuration

1. See the "Firmware Compatibility" section at the end of this document to determine whether or not a firmware upgrade will be necessary.

**Table 1. Fixed-offset step-sweep setup**

| Keystrokes   | Description  |
|--|--|
|  | Configure the source interface as shown in figure 1.   |
| <b>MASTER:</b><br>[START] $F_{Start}$<br>[STOP] $F_{Stop}$<br>[POWER LEVEL] $P_{Master}$                   | Set the master's start/stop frequencies and output power level.  |
| <b>SLAVE:</b><br>[START] $F_{Start\pm Offset}$<br>[STOP] $F_{Stop\pm Offset}$<br>[POWER LEVEL] $P_{Slave}$ | Start and stop frequencies on the slave can be offset above or below the master's start and stop frequencies.<br>Set the appropriate start/stop frequency and output power level.  |
| <b>MASTER AND SLAVE:</b>   |  |
| <b>Note: The slave must be set up and activated prior to the master.</b>                                   |  |
| SWEEP [MENU]   |  |
| <i>Sweep Mode</i> <i>[Step]</i><br><i>[more]</i>   | Configure the sources for a step-sweep measurement.  |
| <i>Start Sweep Trigger</i> <i>[Auto]</i><br><i>[more]</i>  | Automatically trigger the start of the sweep.  |
| <i>[Step Swp Menu]</i><br><i>[Step Points]</i> Pt [ENTER]  | For synthesized step-sweep measurements, set the number of step-sweep points on the master and slave to the same value. If the master is attached to a network analyzer, the analyzer will automatically set the master synthesizer's step size to match the number of points displayed on the analyzer. Since the slave is not connected to the analyzer, make sure the slave has the same number of points selected. |
| <i>[more]</i>  |  |
| <b>SLAVE:</b>  |  |
| <i>Step Swp Pt Trig</i> <i>[Ext]</i>   | Set up the slave for external triggering   |
| <i>Step Control</i> <i>[Slave]</i>   | Activate the slave mode. To avoid sweep synchronization problems, the slave must be activated prior to the master.   |
| <b>MASTER:</b>   |  |
| <i>Step Swp Pt Trig</i> <i>[Auto]</i><br><i>or [Bus]</i><br><i>with Agilent 8757</i>                       | When the master is continuously sweeping and not connected to an external controller, it must automatically trigger the steps. If a network analyzer is the controller in a step-sweep measurement system, the analyzer will automatically change the triggering from "Auto" to "Bus" when the system is preset.   |
| <i>Step Control</i> <i>[Master]</i>  | Activate the master mode.  |

**Table 2. Fixed-offset ramp-sweep setup**

| Keystrokes   | Description   |
|--|---|
|  | Configure the source interface as shown in figure 1.  |
| <b>MASTER:</b><br>[START] $F_{Start}$<br>[STOP] $F_{Stop}$<br>[POWER LEVEL] $P_{Master}$                   | Set the master's start/stop frequencies and output power level.   |
| <b>SLAVE:</b><br>[START] $F_{Start\pm Offset}$<br>[STOP] $F_{Stop\pm Offset}$<br>[POWER LEVEL] $P_{Slave}$ | Start and stop frequencies on the slave can be offset above or below the master's start and stop frequencies.<br>Set the appropriate start/stop frequency and output power level.               |
| <b>MASTER AND SLAVE:</b>   |   |
| MENU SELECT [USER CAL]   |   |
| <i>[Freq Cal Menu]</i><br><i>Swp Span Cal</i> <i>[Always]</i>  | Selecting the sweep span calibration from the "User Cal" menu provides more accurate ramp sweeps. When activated, it calibrates the frequency at the end of each frequency band.                |
| SWEEP [MENU]   |   |
| <i>Sweep Mode</i> <i>[Ramp]</i><br><i>[more]</i>   | Configure the sources for a ramp-sweep measurement.   |
| <i>Start Sweep Trigger</i> <i>[Auto]</i><br><i>[more]</i>  | Automatically trigger the start of the sweep.   |
| <i>[Step Swp Menu]</i><br><i>[more]</i><br><i>[more]</i>   | Access the step-sweep softkey menu to activate the master and slave modes on the respective synthesizers.   |
| <b>SLAVE:</b>  |   |
| <i>Step Control</i> <i>[Slave]</i>   | Only the "Slave" and "Master" options in the step-sweep softkey menu are applicable to the ramp-sweep measurement mode. All the other step-sweep settings are ignored. Activate the slave mode. |
| [SWEEP TIME]     Time  | Check the master's sweep time and set the slave's sweep time to the same value. Fixed-offset ramp-sweep measurements must have the same sweep time set on the master and the slave.             |
| <b>MASTER:</b>   |   |
| <i>Step Control</i> <i>[Master]</i>  | Activate the master mode.   |

## Swept-offset two-tone source

Swept-offset measurements are useful for characterizing frequency translation devices, such as mixers, downconverters and receivers, by testing a swept

intermediate frequency (IF) response. In this type of measurement, the mixer's local oscillator (slave) is set to a fixed frequency, while the master is swept across the specified frequency range. The swept-offset step-sweep and ramp-sweep setups (tables 3 and 4,

respectively) are very similar to the fixed-offset source setups previously described. The primary difference between fixed-offset and swept-offset measurement set-ups occur in the frequency and sweep time settings.

**Table 3. Swept-offset step-sweep setup**

| Keystrokes   | Description   |
|--|---|
|  | Configure the source interface as shown in figure 1.  |
| <b>MASTER:</b><br>[START] $F_{Start}$<br>[STOP] $F_{Stop}$<br>[POWER LEVEL] $P_{Master}$   | Set the master's start/stop frequencies and output power level.   |
| <b>SLAVE:</b><br>[CENTER] $F_{Start} \pm \text{Offset}$<br>[SPAN] 0 [ENTER]  | To synchronize the two Agilent 8360 synthesizers appropriately, the sweep ramp must be actively sweeping on the slave. If a CW frequency is selected as the fixed LO frequency, the sweep ramp is deactivated and the proper handshaking does not occur between the sources. By selecting a center frequency with a zero span, the slave's sweep ramp remains active at the specified frequency. Set the center frequency equal to the master's start frequency $\pm$ an offset. If no offset is implemented, the sweep will start at DC. |
| [POWER LEVEL] $P_{Slave}$  | Set the appropriate power level on the slave.   |
| <b>MASTER AND SLAVE:</b>   |   |
| <b>Note: The slave must be set up and activated prior to the master.</b>   |   |
| SWEEP [MENU]<br><i>Sweep Mode</i> [Step]<br>[more]<br><i>Start Sweep Trigger</i> [Auto]<br>[more]<br>[Step Swp Menu]<br>[Step Points] Pt [ENTER] | Configure the sources for a step-sweep measurement.<br><br>Automatically trigger the start of the sweep.<br><br>For synthesized step-sweep measurements, set the number of step-sweep points on the master and slave to the same value. If the master is attached to a network analyzer, the analyzer will automatically set the master synthesizer's step size to match the number of points displayed on the analyzer. Since the slave is not connected to the analyzer, make sure the slave has the same number of points selected.    |
| [more]   |   |
| <b>SLAVE:</b><br><i>Step Swp Pt Trig</i> [Ext]<br><i>Step Control</i> [Slave]  | Set up the slave for external triggering.<br><br>Activate the slave mode. To avoid sweep synchronization problems, the slave must be activated prior to the master.   |
| <b>MASTER:</b><br><i>Step Swp Pt Trig</i> [Auto]<br>or [Bus]<br>with Agilent 8757<br><br><i>Step Control</i> [Master]                            | When the master is continuously sweeping and not connected to an external controller, it must automatically trigger the steps. If a network analyzer is the controller in a step-sweep measurement system, the analyzer will automatically change the triggering from "Auto" to "Bus" when the system is preset.<br><br>Activate the master mode.   |

**Table 4. Swept-offset ramp-sweep setup**

| Keystrokes               | Description   |
|--------------------------|---|
|                          | Configure the source interface as shown in figure 1.  |
| <b>MASTER:</b>           |   |
| [START]                  | F <sub>Start</sub>  |
| [STOP]                   | F <sub>Stop</sub>   |
| [POWER LEVEL]            | P <sub>Master</sub>   |
| [SWEEP TIME]             | Time  |
|                          | The master's sweep time is usually set to its preset value, or set by an external controller; adjust if necessary.  |
| <b>SLAVE:</b>            |   |
| [CENTER]                 | F <sub>Start ±Offset</sub>  |
| [SPAN]                   | 0 [ENTER]   |
|                          | To synchronize the two Agilent 8360 synthesizers appropriately, the sweep ramp must be actively sweeping on the slave. If a CW frequency is selected as the fixed LO frequency, the sweep ramp is deactivated and the proper handshaking does not occur between the sources. By selecting a center frequency with a zero span, the slave's sweep ramp remains active at the specified frequency. Set the center frequency equal to the master's start frequency ± an offset. If no offset is implemented, the sweep will start at DC.   |
| [POWER LEVEL]            | P <sub>Slave</sub>  |
| [SWEEP TIME]             | Time<br>or<br>Time x 1.03<br><br>(with Agilent 8757)  |
|                          | Set the appropriate output power level on the slave.  |
|                          | Set the sweep time on the slave equivalent to that set on the master. If the master is attached to an Agilent 8757 scalar analyzer, the analyzer will not stop the sweep precisely at the end of the master's sweep ramp. To prevent a system lockup, set the slave's sweep time equal to the master's sweep time plus 3 percent. Adding 3 percent to the sweep time reduces the sweep span by 3 percent. When a reduced sweep is not acceptable, sweep time can be set to the same value as the master. In this case, a lockup can be cleared by re-entering the slave's sweep time. |
| <b>MASTER AND SLAVE:</b> |   |
| MENU SELECT [USER CAL]   |   |
| [Freq Cal Menu]          |   |
| Swp Span Cal             | [Always]  |
| SWEEP [MENU]             |   |
| Sweep Mode               | [Ramp]  |
| [more]                   |   |
| Start Sweep Trigger      | [Auto]  |
| [more]                   |   |
| [Step Swp Menu]          |   |
| [more]                   |   |
| [more]                   |   |
| <b>SLAVE:</b>            |   |
| Step Control             | [Slave]   |
|                          | Only the "Slave" and "Master" options in the step-sweep softkey menu are applicable to the ramp-sweep measurement mode. All the other step-sweep settings are ignored. Activate the slave mode.   |
| <b>MASTER:</b>           |   |
| Step Control             | [Master]  |
|                          | Activate the master mode.   |

## Mixer measurement example

The following test setup illustrates how to measure mixer efficiency/loss with an Agilent 8757C scalar analyzer and two tracking Agilent 8360 series synthesized sweepers in a fixed-offset (fixed IF) configuration. When the measurement system is configured as shown in figure 2, RF-to-IF conversion loss and conversion compression measurements may be performed. With the addition of a directional bridge, return loss and SWR measurements may also be achieved.

Only the master synthesizer is connected to the analyzer via the Agilent 8757 system interface bus and the BNC cables. The AC detection mode is automatically activated upon presetting the analyzer. The master synthesizer will modulate the RF signal with a 27.78 kHz signal and display “PLS.”

The following list, itemizes key measurement considerations:

- Attenuators should be placed at all mixer ports to reduce mismatch uncertainties.
- A filter may be required at the IF port to reduce unwanted mixing (intermodulation) products and leakage signals measured by the analyzer.
- The analyzer’s detector offset feature may be used in conjunction with the analyzer calibration to compensate for the insertion loss created by an IF filter and/or attenuator.
- Only the master synthesizer is interfaced with the analyzer.
- Only the master synthesizer provides the modulated signal; when the slave’s signal remains unmodulated the analyzer can strip off the unwanted local oscillator (LO) feedthrough signal.

The best accuracy and performance can be obtained if the IF signal level is kept at  $-20$  dBm or below. This will keep the detector’s diode in the square law operating region for the best rejection of harmonically-related and spurious signals.

Table 5 presents the setup procedure for a stepped 2 to 19.9 GHz mixer conversion loss measurement for the system shown in figure 2. This setup assumes the measurement requires a fixed IF of 100 MHz, and an LO power level of  $+7$  dBm at the mixer’s LO port.

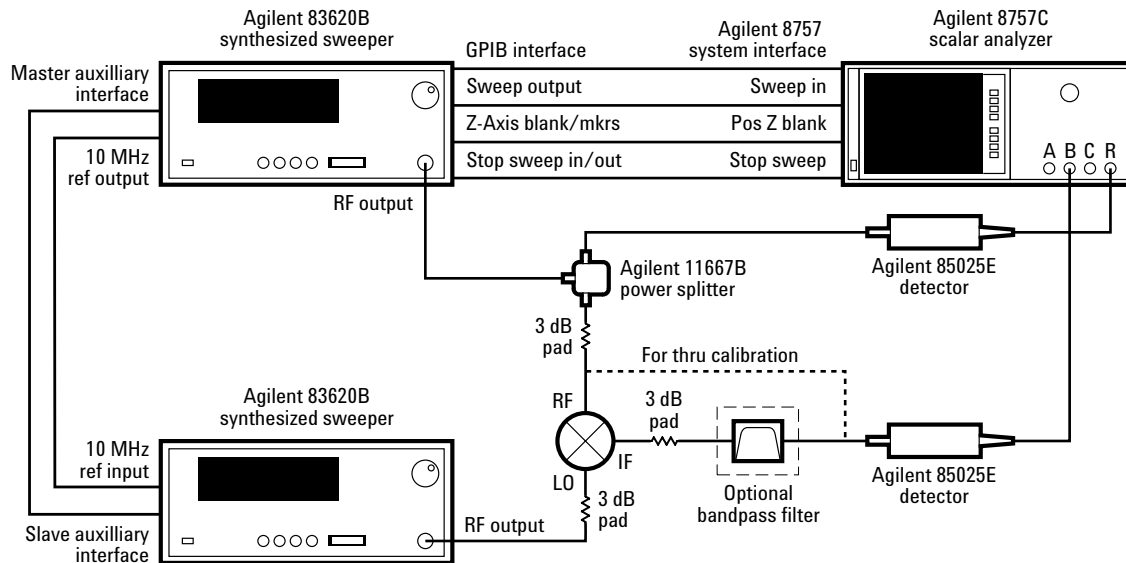

Figure 2. Basic Agilent 8360-based mixer measurement configuration.

**Table 5. Mixer fixed-offset step-sweep measurement setup**

| Keystrokes   | Description  |
|--|--|
|  | Configure the measurement system as shown in figure 2.   |
| <b>Agilent 8757 AND SLAVE:</b><br>[PRESET]   | Preset all the instruments.  |
| <b>MASTER:</b><br>[START] 2 [GHz]<br>[STOP] 19.9 [GHz]<br>[POWER LEVEL] 5 [dBm]                      | Set the master's start and stop frequencies to 2 and 19.9 GHz, respectively.<br><br>Optimal conversion efficiency is generally achieved when the RF port power level is $\geq 10$ dB below the LO port power level. The RF path has about 9 dB of loss; set the master's power level to +5 dBm.  |
| <b>SLAVE:</b><br>[START] 2.1 [GHz]<br>MHz IF.<br>[STOP] 20 [GHz]<br>[POWER LEVEL] 10 [dBm]           | Offset the slave's start/stop frequencies above the master's start/stop frequencies to provide the 100<br><br>Set the slave synthesizer power level to +10 dBm to overcome the loss from the 3 dB attenuator, and provide the required +7 dBm at the LO port of the mixer. For applications which require higher LO power, an amplifier such as an Agilent 8349B may be added between the synthesizer and the mixer's LO port, or an Agilent 83623B/83624B synthesizer may be used. The Agilent 83623B/83624B provide $\geq +17$ dBm up to 20 GHz. |
| <b>MASTER AND SLAVE:</b><br><b>Note: The slave must be set up and activated prior to the master.</b> |  |
| SWEEP [MENU]   |  |
| Sweep Mode [Step]<br>[more]  | Configure the sources for a step-sweep measurement.  |
| Start Sweep Trigger [Auto]<br>[more]   | Automatically trigger the start of the sweep.  |
| [Step Swp Menu]<br>[Step Points] 401 [ENTER]<br>[more]   | Set the number of step points equal to the number of points displayed on the Agilent 8757 scalar analyzer.   |
| <b>SLAVE:</b><br>Step Swp Pt Trig [Ext]<br>Step Control [Slave]                                      | Set up the slave for external triggering.<br><br>Activate the slave mode. To avoid sweep synchronization problems, the slave must be activated prior to the master.  |
| <b>MASTER:</b><br>Step Swp Pt Trig [Bus]<br>Step Control [Master]                                    | The analyzer will automatically change the triggering to "Bus" when the system is preset.<br><br>Activate the master mode.   |
| <b>Agilent 8757:</b><br>[1]  | Select channel 1.  |
| [MEAS] [B/R]   | Configure a B/R measurement.   |
| [CAL] [THRU] [STORE THRU]  | Make a thru calibration of the RF path of the measurement system by removing the B detector from the attenuator or filter at the mixer's IF port, make a direct connection with the attenuator at the RF port (see figure 2), then calibrate.  |
| [DISPLAY] [MEAS-MEM]   | Display the normalized measurement on the analyzer, and reconnect the detector to the attenuator or filter at the IF port.   |

## Performance

An Agilent 83650B-based two-tone measurement system can operate over the full 10 MHz to 50 GHz frequency range with offset frequencies ranging from 0 to 50 GHz. If higher frequencies are desired, Agilent 8360 two-tone measurement systems

may be configured with the Agilent 83550 series mm-wave source modules to cover waveguide bands to 110 GHz. The frequency accuracy and stability of the two-tone measurement system is twice the specified CW (step-sweep) and swept (ramp-sweep) performance of an individual source. User flatness

correction may be used, as described in Agilent product note 8360-2, *Obtaining Flat Test Port Power with the Agilent 8360's User Flatness Correction Feature* (literature number 5988-1546EN), to improve the power flatness at the test port of the device under test.

## Source synchronization cable configuration

The Agilent 8360 source synchronization cable uses five of the 25 pins on the rear panel auxiliary interface connector. The complete source synchronization cable assembly, which may be ordered as Agilent part number 08360-60202, coordinates the bandcrossings, retrace blanking, and step triggering between the sources. The cable may be assembled by connecting two 25-pin D series male connectors as displayed in figure 3.

## Firmware compatibility

The two-tone measurement systems previously described, require Agilent 8360 series synthesized sweepers with firmware revisions of 23 July 1990 or later. To upgrade an Agilent 8360 to the latest revision of firmware, order Agilent part number 08360-60167 if the serial prefix on the rear panel of the instrument is below 3104A, or order Agilent part number 08360-60201 if the serial prefix is 3104A or above. Similarly, to use the Agilent 8360 step-sweep capabilities, the Agilent 8757C/E scalar analyzers require firmware revisions 3.1/4.1 or later, respectively. They may be upgraded to the latest revisions with Agilent part numbers 08757-60099 (C) and 08757-60098 (E).

By internet, phone, or fax, get assistance with all your test & measurement needs

Online assistance:  
[www.agilent.com/find/assist](http://www.agilent.com/find/assist)

Phone or Fax  
United States:  
(tel) 1 800 452 4844

Canada:  
(tel) 1 877 894 4414  
(fax) (905) 282-6495

Europe:  
(tel) (31 20) 547 2323  
(fax) (31 20) 547 2390

Japan:  
(tel) (81) 426 56 7832  
(fax) (81) 426 56 7840

Latin America:  
(tel) (305) 269 7500  
(fax) (305) 269 7599

Australia:  
(tel) 1 800 629 485  
(fax) (61 3) 9210 5947

New Zealand:  
(tel) 0 800 738 378  
(fax) 64 4 495 8950

Asia Pacific:  
(tel) (852) 3197 7777  
(fax) (852) 2506 9284

Product specifications and descriptions in this document subject to change without notice.

Copyright © 2000 Agilent Technologies  
Printed in USA January 11, 2001  
5091-0227E

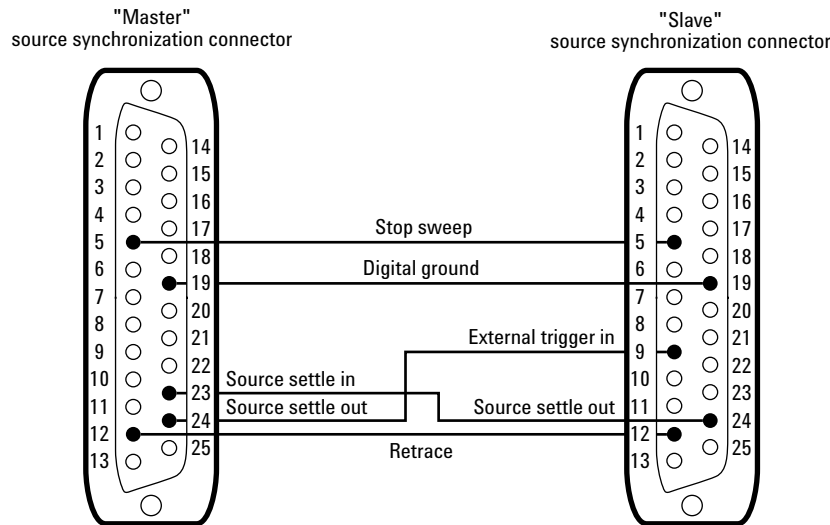

Figure 3. Agilent 8360 source synchronization cable assembly



**Agilent Technologies**

Innovating the HP Way