

APPLICATION NOTE 52

FREQUENCY AND TIME STANDARDS

SECOND EDITION

JANUARY 1962

(Reprinted September, 1962)



HEWLETT-PACKARD COMPANY

1501 Page Mill Road, Palo Alto, California, U.S.A.
Cable "HEWPACK" Telephone (415) 326-7000

HEWLETT-PACKARD S.A.

54-54bis Route des Acacias, Geneva, Switzerland
Cable "HEWPACKSA" Tel. No. (022) 42.81. 50

00051-3

Copyright HEWLETT-PACKARD COMPANY 1962
1501 PAGE MILL ROAD, PALO ALTO, CALIFORNIA, U.S.A.

TABLE OF CONTENTS

Section	Page	Section	Page
I GENERAL	1-1	III FREQUENCY DETERMINATION	3-1
1-1. Introduction	1-1	3-1. Direct Computation Method	3-1
1-2. Frequency Determination Using HF Radio Signals	1-1	3-2. Slope of Time-Error Curve Method	3-1
1-3. Frequency Determination Using LF/VLF Radio Signals	1-3	3-3. Comparison Against VLF	3-4
1-4. Accurate Timekeeping	1-3	IV TIME DETERMINATION	4-1
1-5. Time Scales	1-3	4-1. Introduction	4-1
1-6. Radio Time Signals	1-3	4-2. Great-Circle Distance	4-2
II SYSTEM OPERATION	2-1	4-3. Transmission Mode	4-3
2-1. Introduction	2-1	4-4. Height of Ionosphere	4-5
2-2. Radio Reception	2-1	4-5. Delay Determination	4-5
2-3. HF Time Comparison Measurement	2-4	4-6. Effect of Frequency Drift on the Accumulation of Time Errors	4-5
2-4. HF Measurements Using Time Comparator Unit	2-5	V STABILITY AND SPECTRAL PURITY IN FREQUENCY STANDARDS	5-1
2-5. Photographic Tick Averaging	2-5	5-1. Introduction	5-1
2-6. LF/VLF Comparison Systems	2-6	5-2. Factors Affecting Long- and Short-Term Stability	5-1
A. Using a time interval counter	2-6	5-3. Techniques for Obtaining Spectral Purity	5-1
B. Comparison against CW Transmission	2-6	5-4. Design of ϕ Quartz Oscillator	5-2
C. Comparison against ICW Transmissions	2-6		
D. Using an oscilloscope	2-7		
E. Dymec model 5842-M1 receiver	2-7		
F. VLF phase tracking system	2-7		

Appendix	Page
I TIME	i-1
1. Introduction	i-1
2. Apparent Solar Time	i-1
3. Mean Solar Time	i-1
4. Universal Time	i-1
5. Ephemeris Time	i-2
6. Atomic Time	i-2
7. Sidereal Time Scale	i-2
8. Defining the Solar and Sideral Year from Astronomical Relationships	i-3
II NATIONAL STANDARDS OF TIME AND FREQUENCY	ii-1
1. United States Frequency Standard	ii-1
2. Standard Broadcasts	ii-1
3. Carrier Offset	ii-1
4. Time Corrections	ii-2
III TABLES	
1. Equivalents	iii-1
2. Logarithms of Cosine Function	iii-2
3. Haversines	iii-4
IV HEWLETT-PACKARD REPRESENTATIVES AND OFFICES	iv-1

OTHER HEWLETT-PACKARD PUBLICATIONS ON FREQUENCY AND TIME STANDARDS

The following  publications are available from either your local Hewlett-Packard representative or the Hewlett-Packard Company.

Cutler, Leonard F. "A New Frequency/Time Standard with 5×10^{-10} /Day Stability", Hewlett-Packard Journal, vol. 12, no. 3; November, 1960.

Hartke, Dexter C. "A New Clock for Improving the Accuracy of Local Frequency and Time Standards", Hewlett-Packard Journal, vol. 11, no. 3-4; November-December, 1959.

"Microwave Measurements for Calibration Laboratories",  Application Note 38.

"Utilizing VLF Standard Broadcasts with the Hewlett-Packard Frequency Divider and Clock", Hewlett-Packard Journal, vol. 11, no. 8-10; April-June, 1960.

Cutler, Leonard F. "A Frequency Standard of Exceptional Spectral Purity and Long-Term Stability" (reprint of a paper delivered before the IRE in March, 1961).

SECTION I GENERAL

1-1. INTRODUCTION.

This application note explains the principles involved in maintaining precision frequency and time standards. Several system arrangements are described and system operation is discussed. Considerable emphasis is placed upon practical methods of frequency and time determination.

Hewlett-Packard frequency and time standard systems are used for frequency and time control or calibration at manufacturing plants, physical research laboratories, calibration centers, astronomical observatories, missile and satellite tracking stations, and radio monitoring and transmitting stations. System uses include the following: distributed standard frequencies in factories or research facilities ("house standards"), control of standard frequency and time broadcasts, synchronization of electronic navigation systems, investigation of radio transmission phenomena, frequency synthesizer control, and precise adjustment of single-sideband communications equipment.

The absolute accuracy which can be maintained with Hewlett-Packard systems depends not only upon equipment performance, but also on (a) the accuracy of the master time or frequency source and (b) local comparison and adjustment techniques. Frequency accuracy typically can be maintained within a few parts in 10^{10} . Absolute time synchronization with a master time standard typically can be maintained within a millisecond or less.

High-accuracy master standards of frequency and time are provided in convenient broadcasts from radio stations such as WWV, WWVH, WWVL, NBA, and many others throughout the world (tables 1-2 and 1-3). Proven comparison techniques available to the user are discussed below. By careful use of suitable comparison and adjustment methods, high system accuracy can be maintained.

The necessary equipment characteristics provided by Hewlett-Packard systems include (a) suitable oscillator stability, (b) high-accuracy comparison capability, (c) reliability, and (d) operational simplicity.

The ease with which required system accuracy may be achieved is largely dependent on oscillator stability. Improved long-term stability directly increases the permissible time between oscillator adjustments required to maintain a given absolute accuracy. If an oscillator exhibits long-term stability of 5 parts in 10^{10} per day, for example, adjustments at 20-day intervals can provide accuracy of ± 5 parts in 10^9 (assuming negligible error in both the master standard and comparison method); if long-term stability were 5 parts in 10^9 per day, adjustments at 2-day intervals would be required for the same accuracy.

Long-term stability of both the hp Model 103AR Quartz Oscillator and the Model 104AR Quartz Oscillator is conservatively rated at ± 5 parts in 10^{10} per day with substantially better performance to be expected under normal operating conditions. Such performance results from the use of (a) carefully tested, high-quality crystals, (b) precision-temperature ovens, (c) inherently stable circuitry, and (d) low-power dissipation in crystal (approximately 0.2 microwatt). Design of Hewlett-Packard oscillators includes attention to such details as shock and vibration isolation, shielding, load isolation, and stability with respect to variation of supply voltage.

For example, the effect on output frequency by a ± 4 volt change in the 26V supply voltage is less than ± 1 part in 10^{10} ; the effect of a change in ambient temperature of $\pm 25^\circ\text{C}$ from 25°C is less than ± 3 parts in 10^{10} ; and the effect of any change in load from 50 ohms is less than 1 part in 10^{10} . As a result short-term stability on the order of less than 1 part in 10^{10} can be expected when the oscillator is operating under normal laboratory conditions.

In addition to good long and short-term stability, many applications also require a signal having high spectral purity. This is essential, for example, where a high order of frequency multiplication is to be performed. The hp Model 104AR was designed specifically for these applications. Spectra less than two cycles wide may be obtained in the X-band region by multiplication of its 5 mc output. Signal-to-noise ratios, as measured in a 6 cps bandwidth, of 23 db or better may be typically obtained at 10 gc with the hp Model 104AR.

For a more complete discussion of stability and spectral purity in frequency standards, refer to section V.

Hewlett-Packard instruments which are used as system components are listed in table 1-1 along with their abbreviated names (as used in this application note). Consult your Hewlett-Packard representative (appendix IV) for information on new instruments now in development and not listed here.

Hewlett-Packard frequency and time standard systems can be used in several configurations, depending both on principal system use (i.e. providing accurate frequency or providing accurate time) and on the source of master time or frequency signals (i.e. hf radio transmission or lf/vlf ratio transmissions). The various system arrangements are discussed in the following paragraphs.

1-2. FREQUENCY DETERMINATION USING HF RADIO SIGNALS.

Heterodyne or zero-beat methods of frequency determination using radio signals transmitted by hf

Table 1-1. System Components

Model Number	Complete Name	Abbreviated Name
103AR	Quartz Oscillator	Oscillator
104AR	Quartz Oscillator	Oscillator
113BR	Frequency Divider and Clock	Clock
114BR	Time Comparator	Comparator
120BR	Oscilloscope	Oscilloscope
724BR	Standby Power Supply	Power Supply
725AR	Standby Power Supply	Power Supply

standard-frequency broadcasting stations are commonly used if extreme accuracy is not required. Skywave signals, whose propagation path includes one or more reflections from ionospheric layers are subject to Doppler-effect frequency shift caused mainly by vertical movement of the reflection layers. The frequency shift is a function of the velocity of layer movement. Received signal frequency often differs from the transmitted frequency by several parts in 10^8 per reflection.* Stations which receive multi-hop modes (i.e. several ionospheric reflections) therefore may experience frequency shifts in the order of several parts in 10^7 .

A more accurate method uses high-frequency radio timing signals to measure frequency indirectly through time comparisons. The time-comparison measurements are subject to some error caused by variation in radio transmission delay (mainly a function of ionospheric layer height and transmission mode; refer to section IV for a detailed discussion), but the effects of this error can be minimized by making observations over an extended period of time.

A basic system arrangement which uses time signals from hf radio transmissions is shown in figure 1-1. This system consists basically of an oscillator-driven synchronous-motor clock which is periodically compared with the master time signals.

If the time intervals indicated on the system clock are precisely the same as the master time intervals, oscillator frequency is precisely its nominal value. If the clock loses time, oscillator frequency is low. If the clock gains time, oscillator frequency is high. Accurate measurement of the difference between the time interval indicated on the clock and that from the master time standard permits calculation of average oscillator frequency (or frequency error) during the measurement interval.

* Shaul, J. M., "Adjustment of High-Precision Frequency and Time Standards", *Proc. IRE*, Vol. 38 pp. 6-15; Jan., 1950.

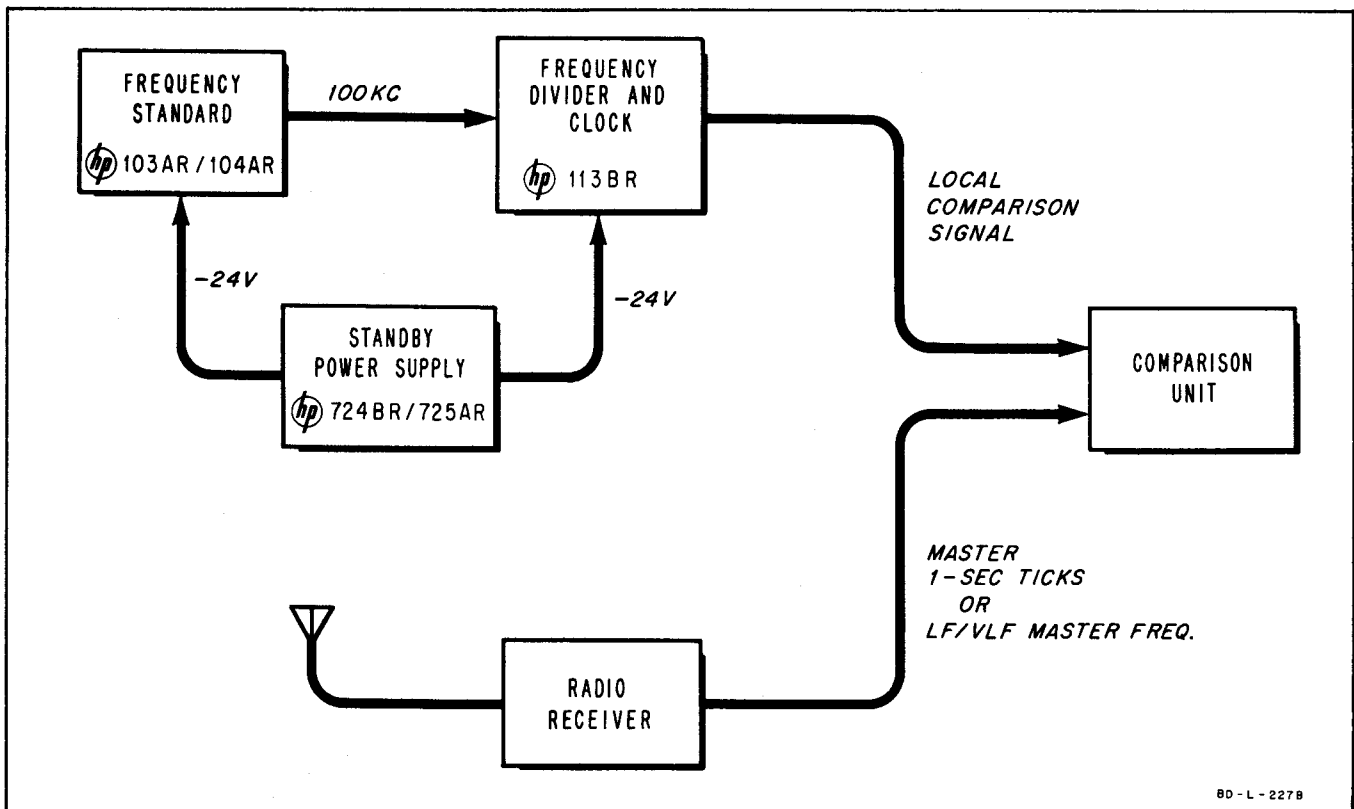

Figure 1-1. Basic Frequency and Time Standard System

Example: A precision oscillator drives a clock which gains 2 milliseconds relative to the master time standard during a time interval of 1,000,000 seconds (about 11.6 days). The average oscillator frequency during the interval is therefore 2×10^{-3} seconds $\div 10^6$ seconds or 2×10^{-9} high with respect to the master time standard.

A precision oscillator can be assumed to have a fairly linear drift rate after its initial run-in period of several weeks. Therefore the value of the average frequency during the measurement interval is approximately equal to the instantaneous frequency at the midpoint of the interval. Thus, in the example given above, the instantaneous frequency 500,000 seconds after the start of the interval would be 2×10^{-9} high. A series of such frequency determinations can be plotted graphically to give a convenient record of oscillator frequency.

Note that determination of oscillator frequency depends on measurement of time intervals, and does not depend on absolute time setting or time synchronization with the master time source. Refer to section III for a complete discussion of frequency determination techniques.

1-3. FREQUENCY DETERMINATION USING LF/VLF RADIO SIGNALS.

Because the propagation of lf and vlf is relatively stable, these bands offer a means of high accuracy frequency transfer in a comparatively short time. Even at great distances, a comparison accuracy of a few parts in 10^{11} may be achieved in a 24-hour period. Comparable accuracy using hf transmissions could require several months.

Frequency comparison against lf/vlf signals can be accomplished in several ways. The systems in section II are offered as accurate measurement techniques; considerations of choice being convenience, flexibility, provision of a continuous record, utilization of available laboratory equipment, and expense.

1-4. ACCURATE TIMEKEEPING.

Equipment requirements for maintaining a precise time standard are similar to those for maintaining a precise frequency standard. Once local synchronization with the master time standard has been made, corrections for oscillator drift can be calculated or determined graphically when the behavior characteristics of the oscillator are known. Close synchronization with a master time standard (by means of radio transmissions) requires determination of the propagation delay between transmitter and receiver. Methods of precise time synchronization are discussed in section IV.

1-5. TIME SCALES.

Several time scales are used for time measurement. The time scales described below are frequently referred to in discussions of precise timekeeping.

For detailed explanations of time units, refer to appendixes I and II and to Time Service Notice No. 4; U. S. Naval Observatory, Washington 25, D. C.; April, 1959. For a discussion of Atomic (AT and A.1) systems, refer to Time Service Notice No. 6; U. S. Naval Observatory, Washington 25, D. C.; January, 1959.

A. UNIVERSAL TIME (UT). Universal Time (UT) or Greenwich Mean Time (GMT) or Greenwich Civil Time (GCT) is a system of mean solar time based on the rotation of the earth about its axis relative to the position of the sun. Several UT scales are in use: Uncorrected astronomical observations used in determining mean solar time are denoted UT0; the UT0 time scale when corrected for the earth's polar variation is denoted UT1; the UT1 time scale when corrected for annual variation in the rotation of the earth is denoted UT2. Time signals transmitted by standard stations are generally based on the UT2 time scale. Although UT is in common use, it is non-uniform because of changes in the earth's speed of rotation.

Astronomical time measurements are frequently referred to the Greenwich mean sidereal time scale (denoted θ) which is based on the rotation of the earth relative to star position. An oscillator frequency of approximately 100,27379091 kc is required to operate the ϕ Model 113BR Frequency Divider and Clock on a mean sidereal time basis. Sidereal time, like UT, is non-uniform.

B. EPHEMERIS TIME (ET). Scientific measurement of precise time intervals requires a uniform time scale. The fundamental standard of constant time is defined by the orbital motion of the earth about the sun and is called Ephemeris Time (ET). (ET is determined from lunar observations.) In 1956, the International Committee of Weights and Measures defined the second as "the fraction $1/31,556,925.9747$ of the tropical year for 12^{h} ET of January 0, 1900" (January 0, 1900 = December 31, 1899).

C. ATOMIC TIME (AT). Molecular and atomic resonance characteristics can be used to provide time scales which are apparently constant and equivalent (or nearly equivalent) to ET. The designation A.1 has been given to the time scale derived from the zero-field (4,0) \longleftrightarrow (3,0) resonance of cesium with one second equal to 9,192,631,770 periods of oscillation. The U. S. Frequency Standard at Boulder, Colorado, is maintained by reference to the A.1 time scale.

1-6. RADIO TIME SIGNALS.

High-frequency (hf) time signals are broadcast in the United States by the National Bureau of Standards over radio stations WWV (located near Washington, D. C.), and WWVH (located in Hawaii). The important characteristics of these and other hf stations transmitting precise time signals are shown in table 1-2.

The U. S. Navy and the National Bureau of Standards are presently transmitting standard lf and vlf signals. The long-range groundwave and stable propagation of lf/vlf transmissions permit direct phase comparison while avoiding the problems of frequency shift and variation in transmission time which is associated with hf transmissions. The characteristics of these and other lf/vlf transmissions are shown in table 1-3. At present, NBS stations WWVB (60 kc) and WWVL (20 kc) are cw and are not modulated with time signals. Navy station NBA broadcasts ICW at 18 kc. Its carrier is pulsed once each second on a 30% duty cycle. Time of day information is provided by omitting "tick" on a programmed basis.

The frequency offset with respect to the USFS of signals transmitted at any given time by NBS stations is available from the Radio Standards Laboratory, National Bureau of Standards, Boulder, Colorado.

Time is announced every 5 minutes in UT by telegraphic code over radio station WWV. Eastern Standard Time is announced in voice before and after each code announcement. 1-second timing pulses (or "ticks") transmitted by WWV normally consist of a 5-millisecond pulse of a 1000-cps sine wave, with exact time at the leading edge of the pulse (figure 1-2). Intervals of 1 minute are marked by omitting the last tick of each minute and by commencing each minute with two ticks spaced by 0.1 second. During the 1-minute binary-coded-decimal (BCD) time code periods (described below), seconds are indicated by a series of five 6-millisecond pulses of a 1000-cps sine wave, followed by a 2-millisecond pulse of a 1000-cps sine wave; exact time occurs at the leading edge of the 2-millisecond pulse.

Station WWVH announces time in telegraphic code every 5 minutes. The 1-second ticks transmitted

by WWVH consist of six cycles of a 1200-cps sine wave (figure 1-2). Intervals of 1 minute are marked by omitting the last tick of each minute and by commencing each minute with two ticks spaced by 0.1 second.

A binary-coded-decimal (BCD) time-of-year signal is broadcast by WWV for 1-minute periods starting at minutes 7, 12, 17, 22, 27, 32, 37, 42, 52, and 57. Figure 1-3 shows pulse arrangement during the 1-second time-frame interval.

A four-pulse 1-2-4-8 BCD group is used. The binary "0" is represented by a 2-millisecond pulse (2 cycles of a 1000-cps sine wave), and the binary "1" is represented by a 6-millisecond pulse (six cycles of a 1000-cps sine wave). Each BCD group can be converted to a decimal digit by adding the represented binary quantities. For example, a long-short-long-short BCD group indicates the digit 5 (1 + 0 + 4 + 0).

Index pulses of 6-millisecond duration are transmitted at 0.1-second intervals. Note that the 0.1-second index pulses mark the start of a BCD pulse group.

All BCD information pulses maintain 10-millisecond spacing; unused areas include index pulses at 10-millisecond intervals. Exact time for 10-millisecond intervals occurs at the leading edge of all pulses. The 1000-cps sine wave within each pulse permits time resolution to 1 millisecond.

An NBS publication describing the time-of-year code "Time Code on WWV", is available from National Bureau of Standards, Boulder Laboratories, Boulder, Colorado.

In addition to time signals, WWV and WWVH transmit (a) audio tones of 440 cps and 600 cps, (b) radio propagation forecasts in telegraphic code (symbol

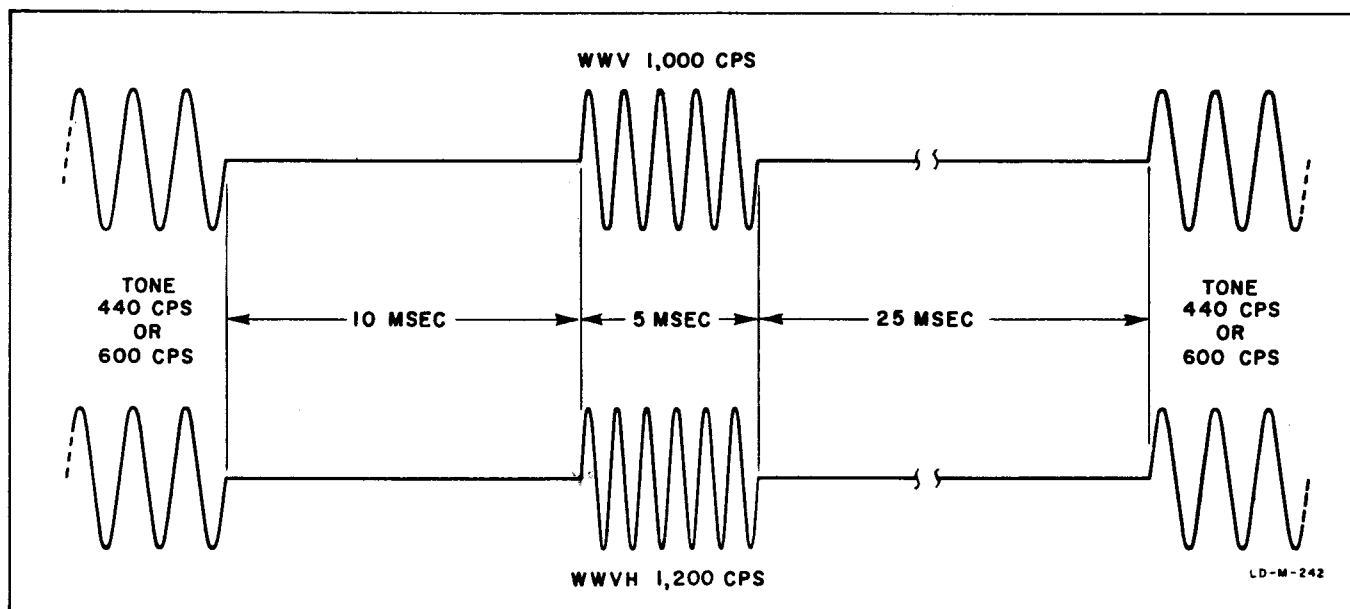

Figure 1-2. Tick Description WWV and WWVH

CALL SIGN		WWV	WWVH	ATA	CHU	FFF
LOCATION	PLACE	Beltsville, Md. U.S.A.	Maui, Hawaii U.S.A.	New Delhi India	Ottawa Canada	Paris France
	LATITUDE	See Note	20° 46' N	28° 34' N	45° 17' 47" N	48° 48' N
	LONGITUDE	See Note	156° 28' W	77° 19' E	75° 45' 22" W	2° 29' W
CARRIER	FREQ. (MC)	2.5 5 10 15 20 25	5 10 15	10	3.330 7.335 14.670	2.5 5
	POWER*	M H H H M L	M M M	M	L M M	L L
SCHEDULE		Continuous except: min. 45-49 each hr.	Continuous except: min. 15-19 each hour and 1900-1934 UT each day	5 days per week, 0534-0600 and 1030-1100 UT.	Continuous	Tues. and 9 hrs. per except min. each hr.
AUDIO MODULATION in addition to time signals		440 cps or 600 cps (alternates) for 2 min. in each 5 min. Time code (BCD) for 1 min. starting min. 7, 12, 17, 22, 27, 32, 37, 42, 52, 57.	440 cps or 600 cps (alternates) for 3 min. in each 5 min.	1000 cps for 4 min. in each 15 min.	None	440 cps (1 min.) 1000 cps (9 min.) 10 min. in each min.
TIME SIGNALS	NORMAL TICK DURATION	5 msec.	5 msec.	5 msec.	200 msec	5 msec.
	TICK MODULATION	1000 cps	1200 cps	1000 cps	1000 cps	1000 cps
	MINUTE MARK	No tick sec. 59: Tick repeated with 100 msec. interval for sec. 00.	No tick sec. 59: Tick repeated with 100 msec interval for sec. 00.	100 msec. tick for sec. 00.	500 msec tick for sec. 00; other ticks omitted (1000 msec tick for hour mark).	100 msec. followed 100 msec. 440 cps sec. 00
	SIGNAL DURATION	Continuous	Continuous	Continuous	Continuous	10 min. in 20 min.
	ADJUSTMENT	step	step	20 msec. step.	50 msec step on 1st day of month	50 msec. step Mon. of month

* L <1 kw
M 1-5 kw
H >5 kw

Note: Antenna locations of WWV

Frequency: 2.5 mc	5 mc	10 mc	15 mc	20 mc
Latitude: 38°59'33.16"N	38°59'30.22"N	38°59'36.1"N	38°59'31.2"N	38°59'32.7"N
Longitude: 76°50'52.35"W	76°50'52.35"W	76°50'52.35"W	76°50'52.35"W	76°50'50.7"W

	FFH	HEW	IBF	JJY	LOL	MSF	OMA	ZUO	
	Paris France	Neuchâtel Switzerland	Torino Italy	Tokyo Japan	Buenos Aires Argentina	Rugby England	Prague Czechoslovakia	Johannesburg	Olifantsfontein Union of South Africa
T N	48° 46' N	47° 00' N	45° 03' N	35° 42' N	34° 37' S	52° 22' N	50° 07' N	26° 11' S	25° 58' S
T W	2° 20' E	6° 57' E	7° 40' E	139° 31' E	58° 21' W	1° 11' W	14° 35' E	28° 04' E	28° 14' E
14.670	2.5 5 10	2.5 5	5	2.5 5 10 15	2.5 5 10 15 20 25	2.5 5 10	2.5	10	5
M	L L L	L L	L	M M M M	M M M M M	L L L	M	L	M
	Tues. and Fri. 9 hrs. per day except min. 25-30 each hr.	2.5 mc: Sat. 0700- Tues. 0700, Wed. 0700- Fri. 0700. 5 mc: Tues. 0700- Wed. 0700, Fri. 0700- Sat. 0700 UT.	Daily 0700-0730, 1100-1130 UT, except Sun.	2.5 mc: Daily 0700-2300 UT except min. 29-30 each hr. 5 mc: Mon. except min. 9-19, 29-39, 49-59 each hr. 10 mc: Wed. except min. 9-19, 29-39, 49-59 each hr. 15 mc: continuous except min. 29-39 each hr.	Daily 1100 - 1200, 1400 - 1500, 1700 - 1800, 2000 - 2100, 2300 - 2400 except Sun.	Continuous except min. 15-20 each hr.	Continuous except min. 40-45 each hr.	Continuous except min. 15-25 each hr. and 0630 - 0700 UT each day.	
	440 cps (1 min.) and 1000 cps (9 min.) for 10 min. in each 20 min.	500 cps square wave for 5 min. in each 60 min.	440 cps or 1000 cps (alternates) for 5 min. in each 10 min.	1000 cps for 4 min. in each 5 min.	440 cps or 1000 cps (alternates) for 4 min. in each 5 min.	1000 cps for 10 min. in each 15 min.	1000 cps for 4 min. in each 15 min.	None	
	5 msec.	10 msec.	5 msec.	20 msec.	5 msec.	5 msec.	5 msec.	5 msec.	
	1000 cps	5 carrier interruptions 1 msec. x 1 msec. (start of 1st int. is exact sec.)	1000 cps	Carrier interruption before sec.	1000 cps	1000 cps	1000 cps	1000 cps	
	100 msec. tick followed by 100 msec. at 440 cps for sec. 00.	250 carrier interrup- tions for sec. 00.	Tick repeated 7 times with 10 msec. inter- vals for sec. 00.	200 ms interruption before sec. 00.	No tick sec. 59.	100 msec. tick for sec. 00.	100 msec. tick for sec. 00.	500 msec. tick for sec. 00.	
	10 min. in each 20 min.	5 min. in each 10.	5 min. in each 10	Continuous	4 min. in each 60 min.	5 min. in each 15 min.	10 min. in each 30. No tick min. 20- 25 each hr.	Continuous	
1st	50 msec. step on 1st Mon. of month.	Steering	Step	10 msec. step.	20 msec. step.	20 msec step on 1st day of month	Step	50 msec. step	

1961

CH-E-369

20 mc 25 mc
38°59'32"N 38°59'36"N
35°W 76°50'50"W 76°50'51"W

Table 1-2. HF Standard Time Signal Stations

Table 1-3. LF and VLF Frequency and Time Standards

CALL SIGN		WWVB	WWVL	NBA	DCF77	GBR	MSF	OMA
LOCATION	PLACE	Boulder, Colorado U.S.A.	Sunset, Colorado U.S.A.	Summit, C. Z. Panama	Mainflingen Germany	Rugby United Kingdom		Podšbrady Czechoslovakia
	LATITUDE LONGITUDE	40° 00'N 105° 16'W	40° 02'N 105° 27'W	9° 04' 30"N 79° 34' 30"W	50° 01'N 9° 00'E	52° 22'N 1° 11'W		50° 08'N 15° 08'E
CARRIER	FREQUENCY	60 kc	20 kc	18 kc	77.5 kc	16 kc	60 kc	50 kc
	OFFSET	Approx. -150×10^{-10} during 1961	Approx. -150×10^{-10} during 1961	Approx. -150×10^{-10} (rel. to A.1) during 1961	—	—	—	—
	POWER*	Low	Med	High	Med	High	Med	Low
SCHEDULE		Mon. 1530 - Fri. 2400 except 1430 - 1530 UT Tues. thru Fri.	Continuous	Continuous except Wed. 1300 - 2100 UT	Mar thru Oct, weekdays 0700-0210; Nov thru Feb, 0700-0010; telegraphic traffic 1200-1859; no transmission after 1900 UT before Sun or holiday.	Daily, approx. 22 hrs.	Daily, 1430 - 1530UT	Continuous
MODULATION		Call sign broadcast at min. 00, 20, 40 each hour.	Call sign broadcast at min. 00, 20, 40 each hour.	Int. time sigs, call - sign and offset from A. 1 in parts in 10^{10} broadcast periodically	Standard 440 cps tone, 0710-0727. Standard 200 cps tone, 1010-1027. 1-sec ticks: . . . her (a) 20 msec pulsed carrier or 20 msec 440 cps tone, sec 00 prolonged (100 msec); or (b) pulsed carrier for 100 msec, sec 00 prolonged (500 msec); 0728-0735, 0800-0810, 1028-1035, 1100-1110, 1900-2010, 2057-2110, 2157-2210, 2257-2310, 2357-0010, 0057-0110, 0157-0210 UT. 2-min ticks (min 00, 02, 04, etc.): 440 cps for 40 msec; 0700-0709, 0736-0759, 0811-1009, 1036-1059, 1111-1200 UT. Standard deviation (σ) = 10.06 msec for 20 msec 1-sec ticks and 2-min ticks. Adjustment: 50 msec step Wed at 1400 UT.	Int. time sigs, telegraphic traffic	1000 cps for 10min. in each 15 min.	Continuous except 1000 - 1101 UT: 100 msec pulsed carrier marks exact sec with sec 00 prolonged to 500 msec; accuracy $\pm 10 \times 10^{-9}$ 1000 - 1101 UT: continuous carrier with interruption for call sign each 15 min.
TIME SIGNALS		None at present but planned for near future	None at present but planned for near future	Dash starts on exact sec. Dash omitted on sec. 29, 56, 57, 58, 59 each min. Other dashes omitted during sec. 51-55 of last 5 min. of each hour, first dash each hour prolonged Accuracy: same as carrier	Time sigs, 0955 - 1000, 1755 - 1800UT			

* Low < 10 kw
Med 10-100 kw
High > 100 kw

1961 CR-1-666

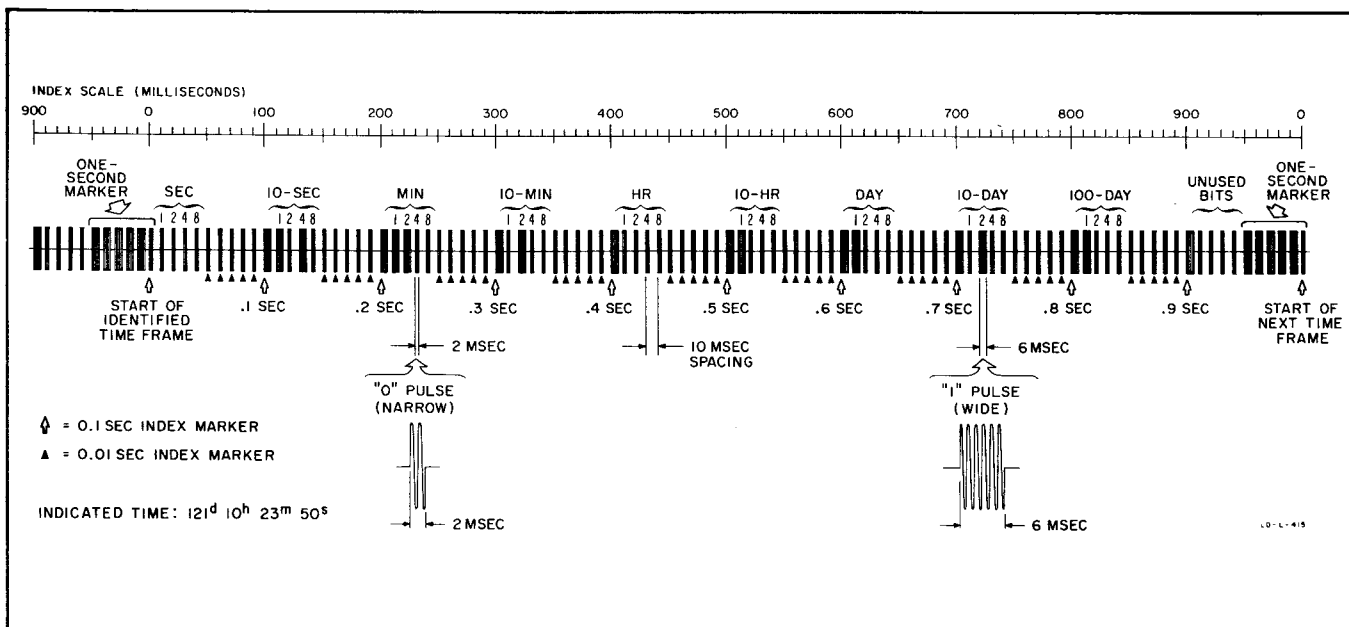

Figure 1-3. Time Code WWV, 36-Bit Binary-Coded-Decimal

consists of the letter W, U or N followed by a numeral), and (c) geophysical alerts in telegraphic code (symbol consists of the letters AGI followed by AAAA, EEEEE, or three long dashes).

Receiving stations which are equidistant from WWV and WWVH may experience tick interference on 5, 10, and 15 mc. This problem can be reduced by either (a) using a directional antenna which favors the desired signal or (b) scheduling measurements for a time when only one station is transmitting. Station WWV is silent from minute 45 to minute 49 of each hour. Station WWVH is silent during minute 0 to 3, 15 to 18, 30 to 33, and 45 to 48 of each hour and from 1900 to 1934 UT each day.

Tick timing is adjusted at infrequent intervals in steps up to 50 milliseconds. Timing normally is adjusted at the beginning of the calendar year.

For optimum precision in maintaining a time standard, the U.S. Naval Observatory determines and publishes corrections for transmitted time signals. About two

months after a particular transmission, preliminary corrections are given in "Time Signals, Bulletin B". Final corrections are released about six months after a particular transmission in "Time Signals, Bulletin A". Both of the above publications are available from the U. S. Naval Observatory, Washington 25, D. C.

Calculations of oscillator frequency which are based on the UT2 time transmissions from WWV may be corrected to the ET scale using frequency offset information which is published periodically in "Time Signals, Bulletin B", the "Proceedings of the IRE" (published monthly by the Institute of Radio Engineers, Inc., 1 East 79 Street, New York 21, New York), and "Deviations of the Frequencies Broadcast by Station WWV with Respect to the United States Frequency Standard" (available from National Bureau of Standards, Boulder Laboratories, Boulder, Colorado). The published corrections refer directly to the transmitted frequency of WWV, but since the WWV time signals are locked to the frequency transmission, the corrections are valid for frequencies whose value has been determined from the time signals.

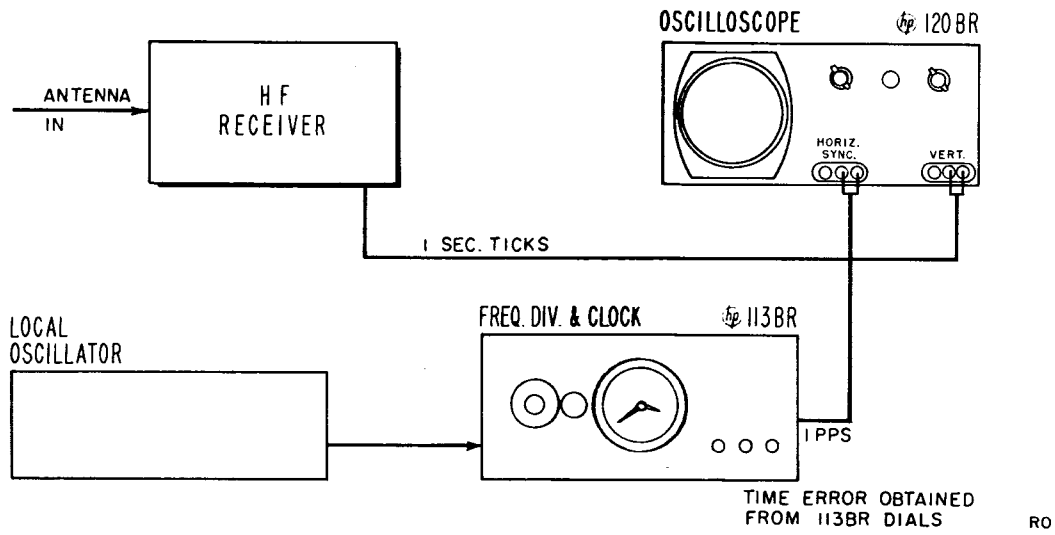

METHOD A. Requires Adjustment of Model 113BR Tick Phasing

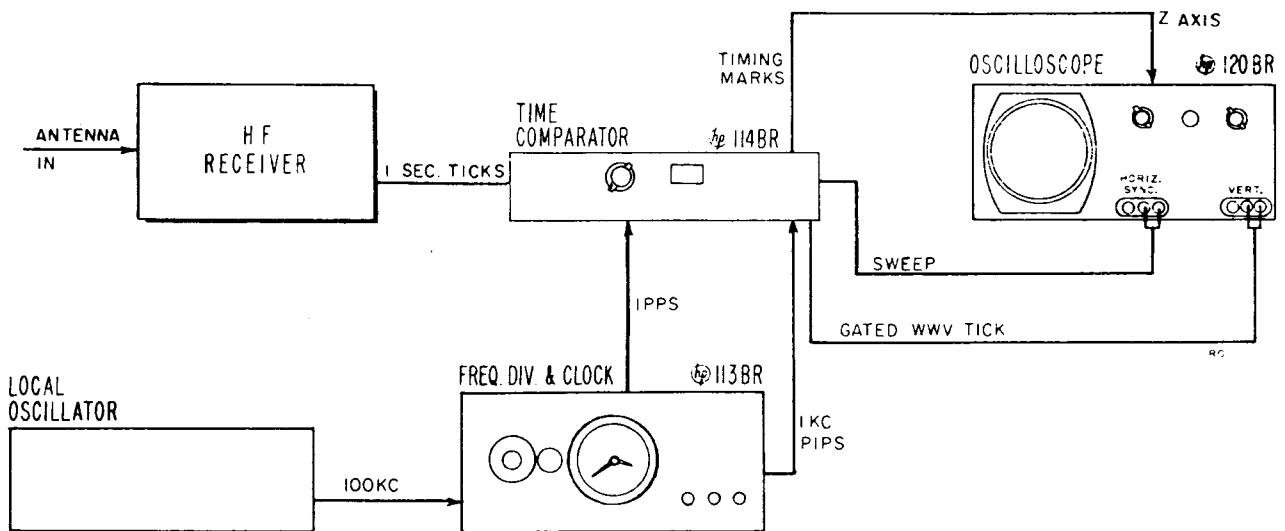

METHOD B. Simplified Time Comparison without Shifting Phase of Local Ticks

Figure 2-1. Comparison Units for Basic HF System

SECTION II

SYSTEM OPERATION

2-1. INTRODUCTION.

This section describes the general operation of typical comparison systems such as those illustrated in figures 2-1 and 2-2. Detailed step-by-step instructions for installation and operation are given in the manuals which are supplied with the equipment.

2-2. RADIO RECEPTION.

Radio receiver requirements differ widely, depending especially on the location of the receiving station. For hf reception, the receiver should be of communications receiver quality, tunable to all necessary frequencies (for WWV: 2.5, 5, 10, 15, 20, and 25 mc). Lf/vlf reception requires a high sensitivity receiver, capable of effectively rejecting adjacent channel signals and covering a spectrum of 14-30 kc or higher.

Comparison measurements can be speeded and simplified by giving careful attention to antenna design, location, and orientation. A directional antenna is preferred for hf reception and should be oriented to favor the transmission mode which consistently provides the shortest propagation path. Suitable lf/vlf reception may be obtained with a long wire antenna or loop antenna. Excellent results are obtained in Palo Alto, California, with a Dymec loop antenna (Ⓢ stock number 9060-0020).

Accuracy of measurements using hf timing signals can be greatly improved by observing a few precautions to lessen the effect of erratic variation in propagation delay:

- 1) Schedule observation for an all-daylight or all-night transmission path between transmitter and receiver. Avoid twilight hours.
- 2) Choose the highest reception frequency which provides consistent reception.
- 3) Observe tick transmission for a few minutes to get the "feel" of propagation conditions. The best measurements are made on days when signals show little jitter or fading. If erratic conditions seem to exist, indicated by considerable fading and jitter in tick timing, postpone the measurement. Ionospheric disturbances causing erratic reception sometimes last less than an hour, but may last several days.
- 4) Make time comparison measurements using the ticks with the earliest consistent arrival time.

Lf/vlf propagation is affected less by atmospheric conditions than hf; however, variations in propagation conditions do exist and cannot be ignored when making accurate comparison measurements. As with higher frequencies, lf/vlf transmission is affected

by diurnal variations, i.e. propagation path phase shifts occurring at sunrise and sunset. Factors affecting path phase velocity include ionospheric conditions, ground conductivity, and surface roughness.

Path phase is considerably more stable when neither sunrise nor sunset is present along the path. Furthermore, studies have shown that path phase is much more stable during the all sunlight period than at night.

Daytime propagation is subject to sudden ionospheric disturbances (S.I.D.) caused by solar flares. S.I.D. are characterized by a rapid shift in phase, then an exponential recovery, caused by a sudden depression and slow recovery of the ionosphere (D-layers). S.I.D. are also triggered by man-made events.*

S.I.D. from solar disturbances seldom affect nighttime propagation. However, magnetic storms are likely to cause minor phase instabilities at night, but these disturbances can be averaged out over a period of several hours.

The graph in figure 2-3 shows a WWVL phase comparison (received in Palo Alto, California) over a typical 24-hour period. The measurement system used is similar to that in figure 2-2 (method A). Comparison is made against the Hewlett-Packard house frequency standard (Ⓢ Model 103AR Quartz Oscillator).

The down path phase shift is first shown at the left of the chart, between approximately 5:30 and 6:30 AM. Then slope is constant until approximately 6 PM, at which time the sunset path phase shift occurs. Between sunset and dawn the slope approximates the daytime slope with the exception of minor propagation instabilities. The cycle repeats beginning at 5:30 AM the next morning. The morning shifts do not change direction, as the chart appears to indicate. The sudden change toward the bottom of the chart is caused when the analog recorder changes range. Without the range change, the record would be approximately trapezoidal in shape. Periodic "pips" are 20 minute-identification marks broadcast by WWVL.

Because of the relatively short comparison periods required when using lf/vlf transmissions, the phase shift shown in figure 2-3 should not present a serious problem if the user is aware of them. An excellent coverage of vlf propagation phenomena appears in the June 1957 IRE Proceedings.

* Reder, F. H. "Frequency Transfer by VLF Transmissions", U. S. Army Signal Research and Development Laboratory, October 28, 1961.

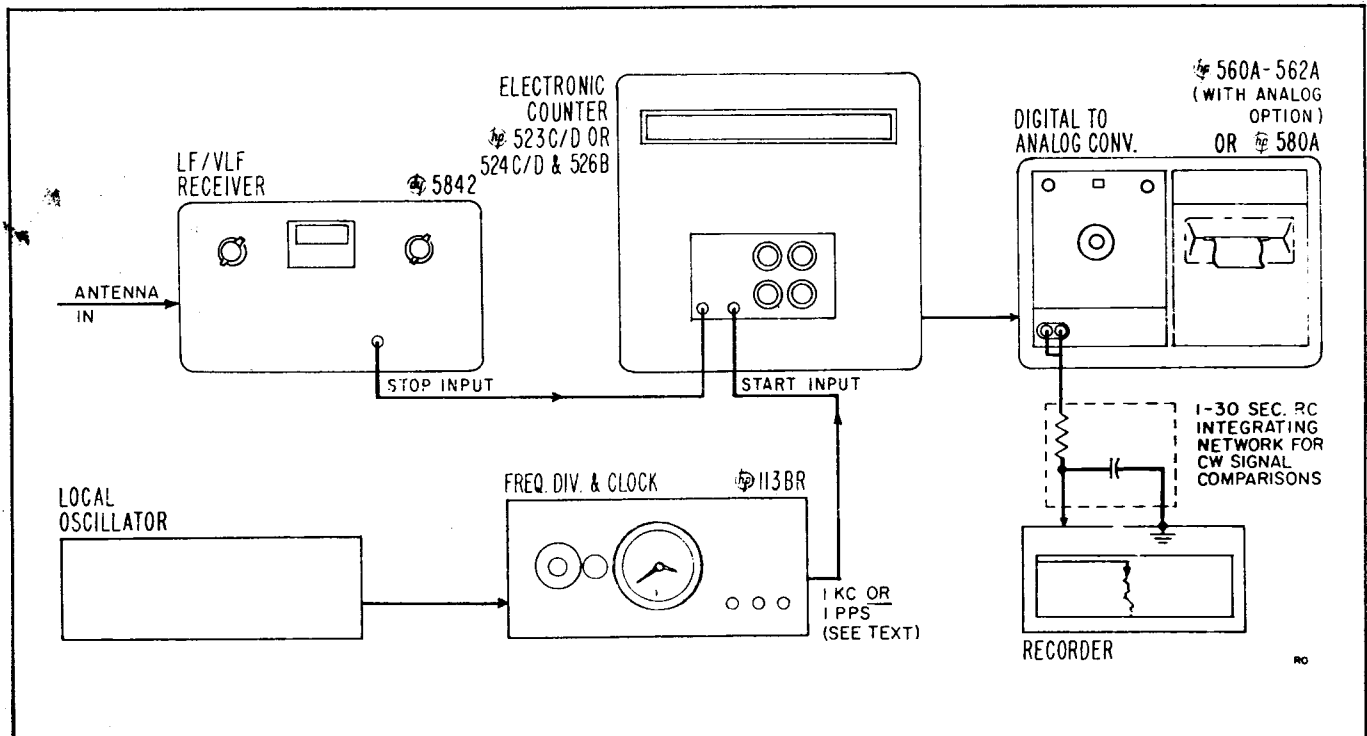

METHOD A. LF/VLF Comparison using Time Interval Counter

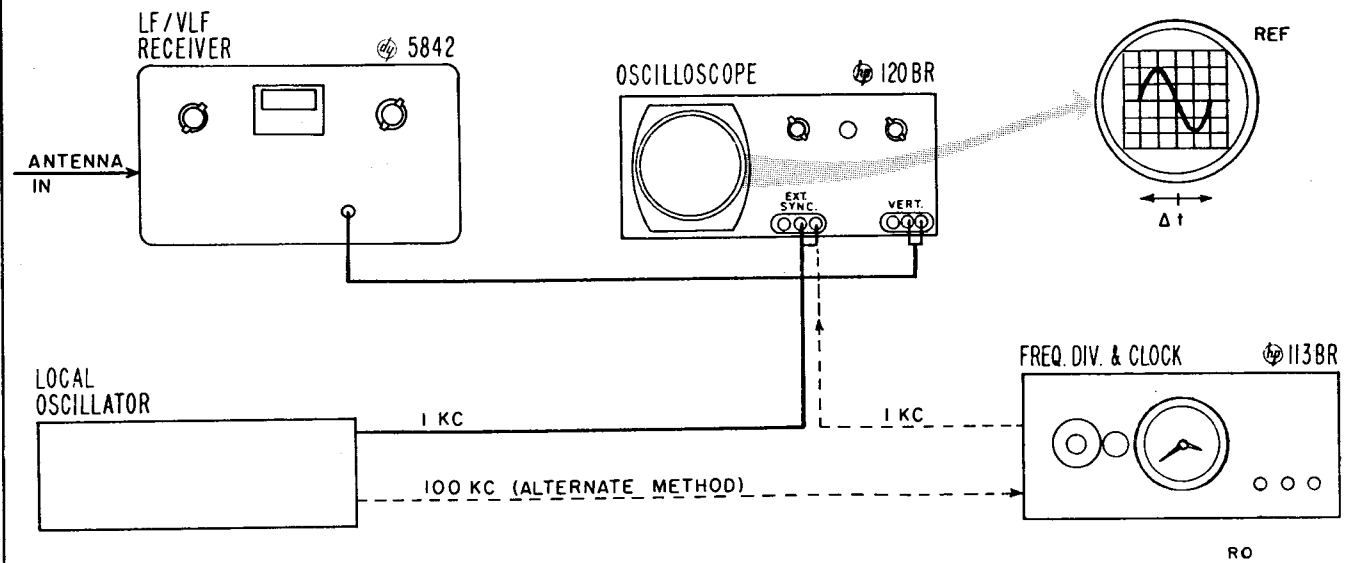

METHOD B. LF/VLF Comparison using Oscilloscope

Figure 2-2. LF/VLF Comparison Systems (Sheet 1 of 2)

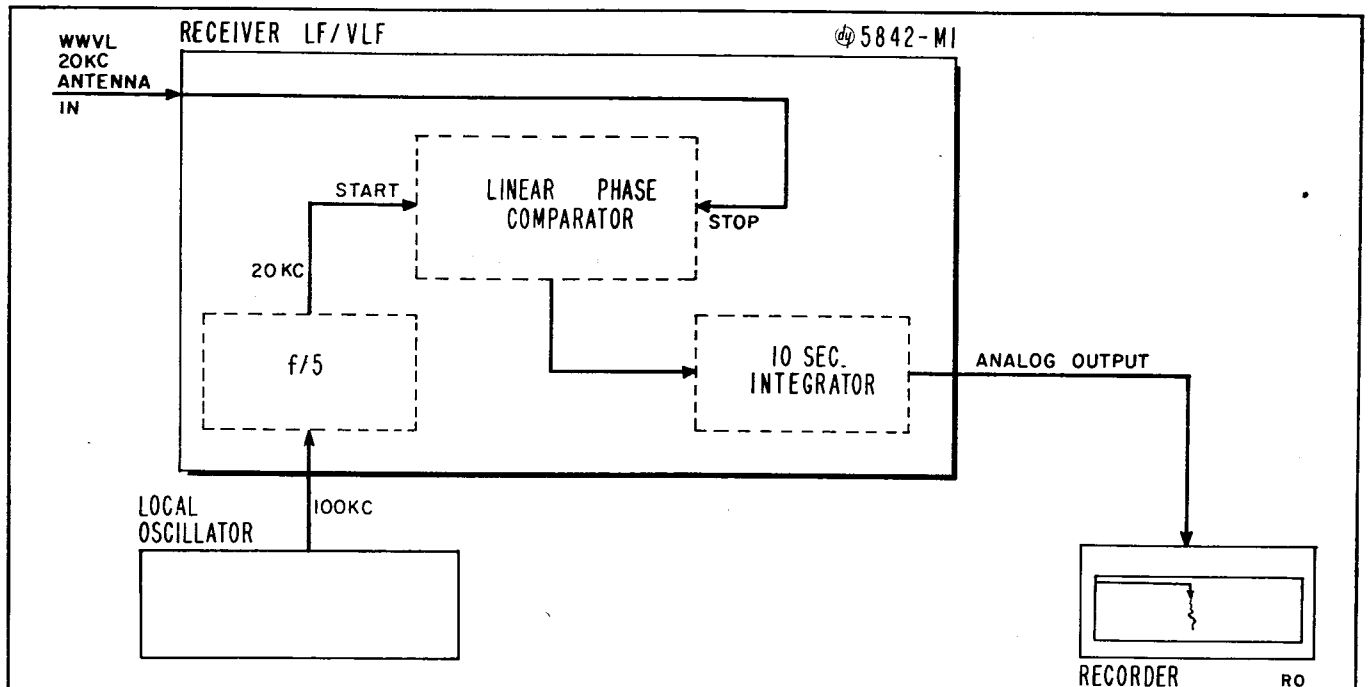

METHOD C. LF/VLF Comparison using Dymec Model 5842-M1

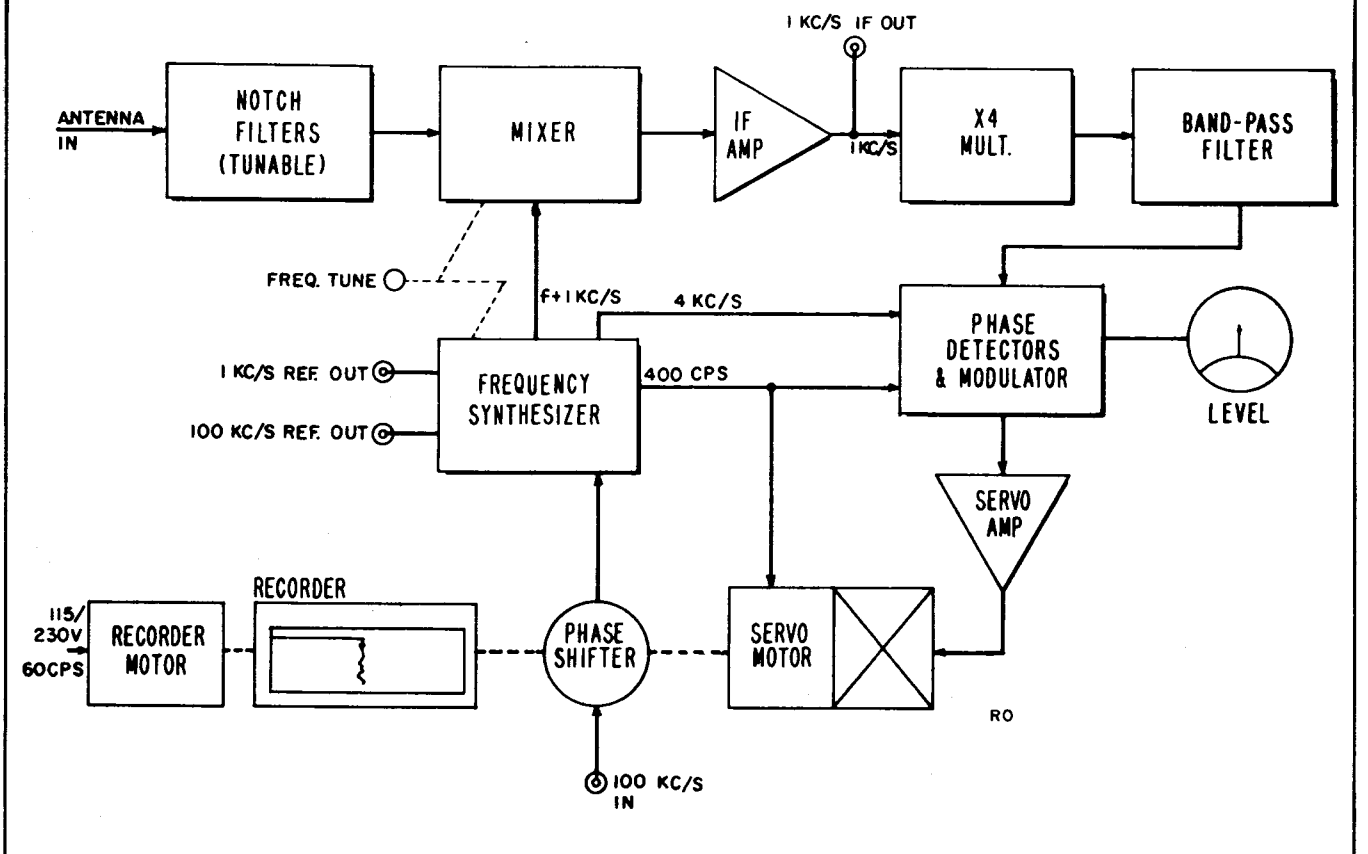

METHOD D. LF/VLF Comparison using Dymec Model 2365A

Figure 2-2. LF/VLF Comparison System (Sheet 2 of 2)

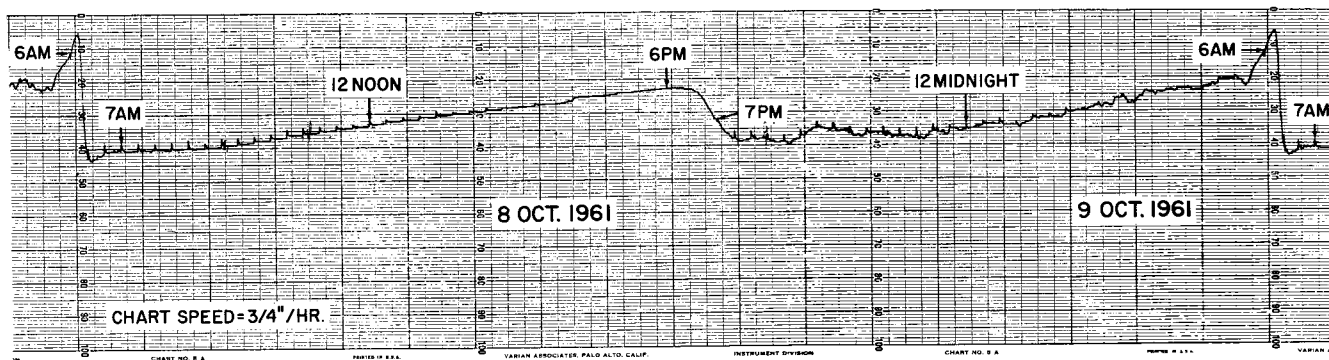
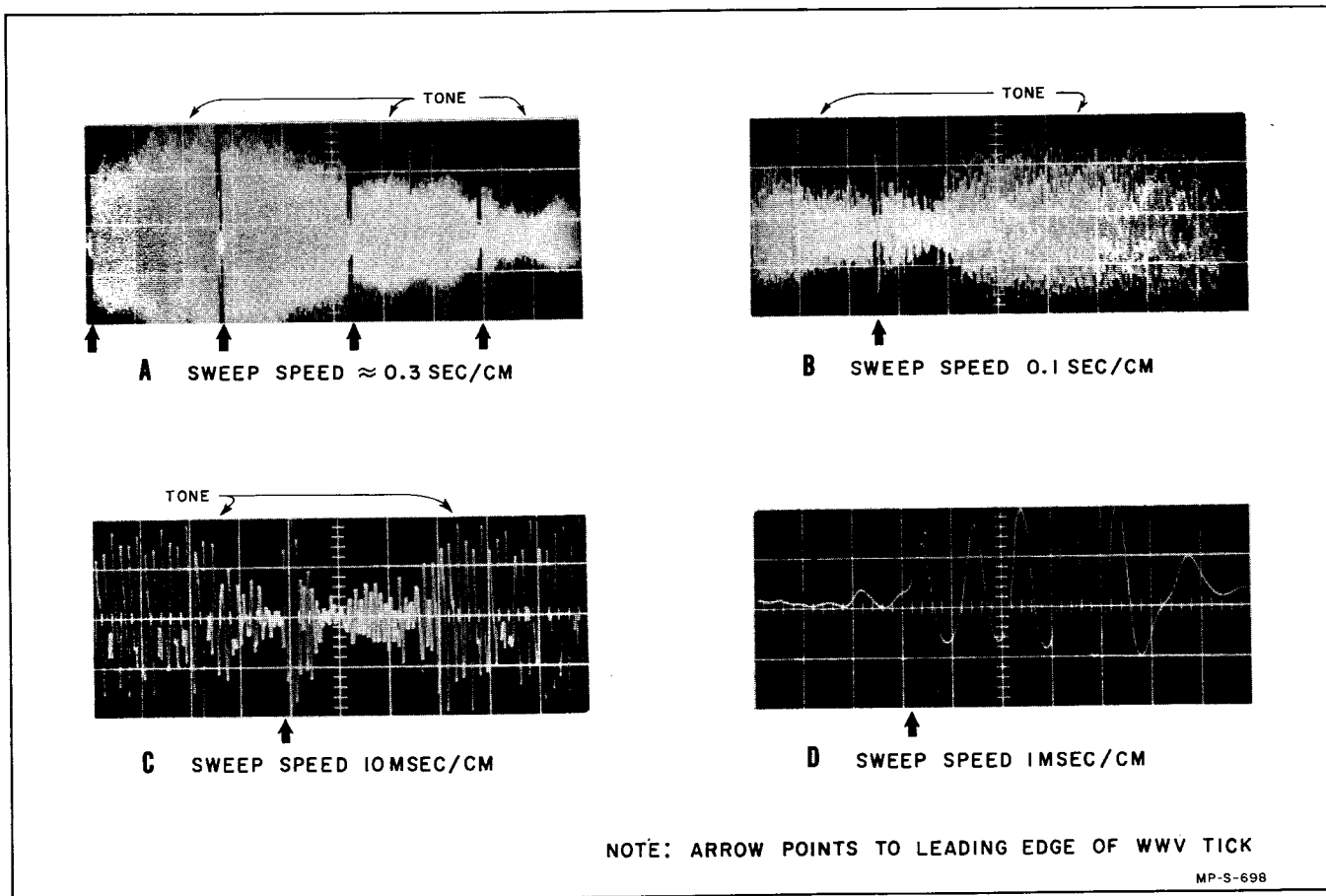

Figure 2-3. Typical 24-Hour Period Phase Comparison Graph of WWVL

2-3. HF TIME COMPARISON MEASUREMENT.

The basic oscillator-clock-oscilloscope system (figure 2-1) uses the tick output of the clock to trigger the oscilloscope sweep. By observing the WWV tick while adjusting the phasing of the clock tick output, both ticks can be brought into time coincidence or near-coincidence. The calibrated time reference control (reading accuracy better than 10 microseconds for the Model 113BR) then gives the desired clock time reference.

During the adjustment procedure a selected portion of the WWV tick is positioned on a selected reference line on the oscilloscope screen. Any easily identified part of the WWV tick near the tick leading edge may be selected (such as the zero-crossing of the second cycle), but future time comparisons must be referenced to the same point. Likewise, any part of the oscilloscope screen can be used for reference (such as the center vertical graticule line or the start of the sweep), but again future measurements must be referenced to the same point.



NOTE: ARROW POINTS TO LEADING EDGE OF WWV TICK

MP-S-698

Figure 2-4. Typical WWV Waveforms With Severe Amplitude Fading

The oscillograms in figure 2-4 show the appearance of typical WWV signals (with severe amplitude fading) on an Φ Model 120AR Oscilloscope during a time-comparison measurement. Note that in figure 2-4D the WWV tick starts about 3.2 milliseconds after the time of sweep triggering. The time read from the clock time reference control in this case is 3.2 milliseconds ahead of the start of the received WWV tick.

2-4. HF MEASUREMENTS USING TIME COMPARATOR UNIT.

Systems which include the Φ Model 114BR Time Comparator permit clock tick and other outputs to remain on-time during the time-comparison measurement. The comparator permits a controlled delay to be generated after the clock tick output. The measurement procedure is similar to the basic procedure described in paragraph 2-3 but is simplified by comparator-generated time marks supplied to the oscilloscope and by direct-reading delay dials on the comparator.

During operation, the comparator switches which adjust oscilloscope sweep time and comparator delay are set to give a convenient oscilloscope presentation of the WWV tick. Comparator delay dials always indicate the delay between the clock tick and the start (left end) of the oscilloscope sweep. The time interval between the clock tick and the selected reference point on the WWV tick is equal to the Φ Model 114BR delay dial reading plus the interval between the start of the oscilloscope sweep and the reference point on the WWV tick as indicated by the intensity-modulated time marks (figure 2-5).

The WWV tick appears to be relatively free of jitter, and readings can easily be made to within 10 microseconds by switching to 1-millisecond sweep time. Only one cycle on the WWV tick appears on the oscilloscope at this sweep speed. As shown in figure 2-5, intensity markers occur at intervals of 0.1 millisecond along the base line of the sweep. The 10-microsecond dashes on the waveform start at even 0.01 millisecond intervals, and spaces start at odd 0.01 millisecond intervals.

2-5. PHOTOGRAPHIC TICK AVERAGING.

Since random variations in the radio propagation path cause variation in the arrival time of each WWV tick, the accuracy of time-comparison measurements depends to a large extent on the ability of the operator to judge the time of tick arrival. Excellent results can be obtained with a photographic averaging technique using an Φ Model 196A Oscilloscope Camera or equivalent. A time exposure of several seconds produces an oscillogram from which the time of earliest consistent tick arrival can easily be determined. If the oscilloscope sweep time is accurately calibrated, the location of the tick reference point on the oscillogram can be adjusted to the chosen oscilloscope

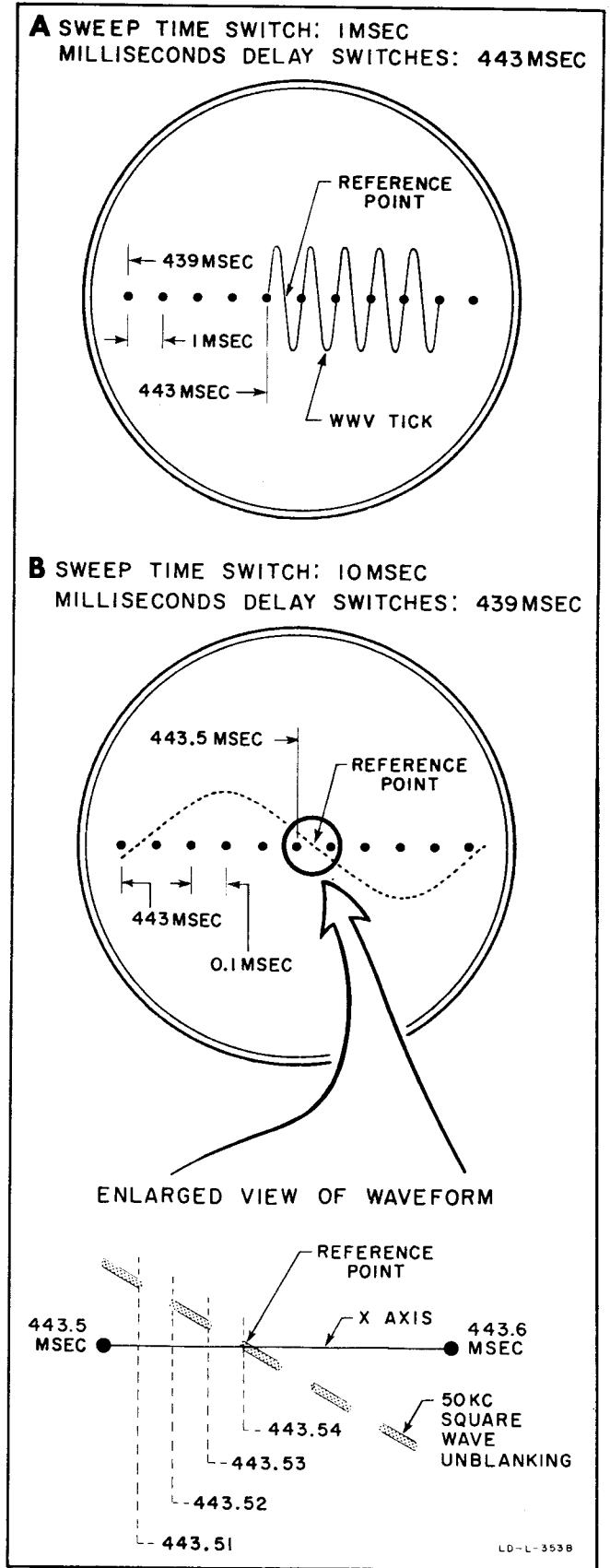

Figure 2-5. Waveform Interpretation Using Time Comparator

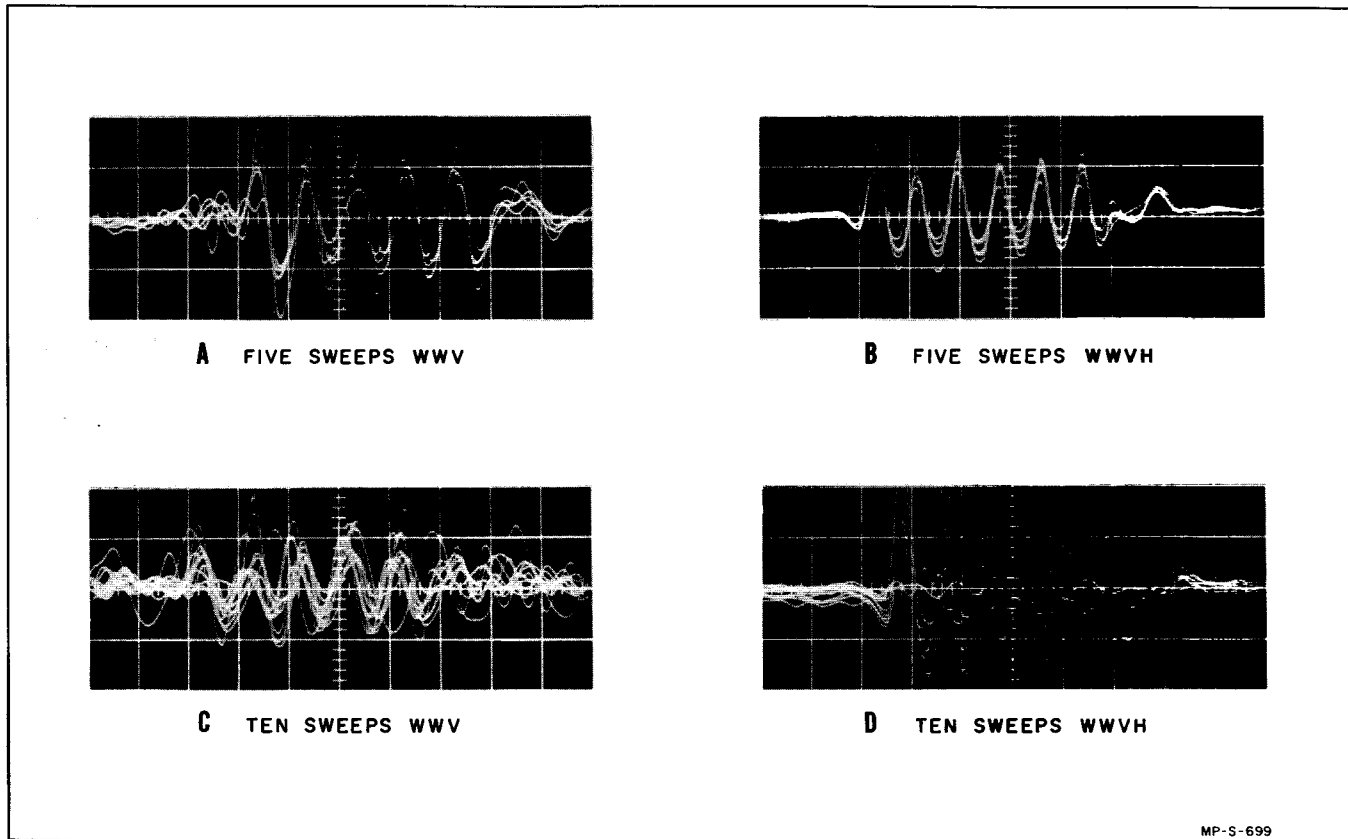

Figure 2-6. Photographic Tick Averaging

reference point to determine the time-comparison reading. Figure 2-6 shows several examples of time-exposure oscillograms using this technique.

2-6. LF/VLF COMPARISON SYSTEMS.

A. USING A TIME INTERVAL COUNTER. Frequency comparison against vlf signals can be made using the equipment shown in figure 2-1 (method A). The method is convenient, automatic, and provides a continuous record.

B. COMPARISON AGAINST CW TRANSMISSION. The National Bureau of Standards VLF station, WWVL, broadcasts cw at 20 kc from Boulder, Colorado. Comparison measurements are made by using the 1-kc output from the Model 113BR clock to start the interval count, and the 20-kc carrier to stop the time interval measurement. The time interval counter trigger level and slope controls permit selection of given and repeatable points on the start and stop signals. An analog record of the time interval counter readings gives the relative time drift of the oscillator under test as compared to WWVL.

It is possible to achieve a comparison accuracy of one part in 10^9 in less than one hour using this method. For example: The jitter on the Model 113BR output is less than 1 microsecond and time interval measurement on a 1-megacycle counter can be made to within

a few microseconds. Since there are approximately 4×10^7 microseconds in one hour, a frequency difference between the local oscillator and the lf/vlf standard transmission of one part in 10^9 would result in a time drift of about 4 microseconds in an hour. Thus, a part in 10^9 would be well within the measurement resolution of the equipment.

C. COMPARISON AGAINST ICW TRANSMISSIONS.

An example of an ICW standard broadcast transmission is that of the U. S. Navy VLF station NBA, which transmits on a carrier of 18 kc from Panama. The carrier of NBA is keyed at a 1 pps repetition rate with a 30% duty cycle. That is, the carrier is on for 0.3 second and off for 0.7 second.

Frequency comparison measurements with ICW signals can be made only during the "on" time of the carrier. The equipment setup is the same as that for comparison measurements with WWVL except that the 1-second tick from the Model 113BR is used as the start signal to the time interval counter instead of 1 kc. In either case, of course, the start signal is derived from the local standard to be calibrated.

So that comparison can be made to a given point on the vlf carrier, the pulse from the clock is positioned by the Time Reference Control on the clock panel to occur in the middle or late portion of the received

vlf pulse (in this way, any variations during the early part of the vlf carrier pulse will not affect the character of the carrier cycle used to stop the time interval counter). The clock pulse is then used to start a time interval measurement on the time interval counter. The measurement will be stopped by the point on the next cycle of the vlf carrier which corresponds to the trigger level and slope setting of the stop channel controls on the time interval counter.

Because the transmission, in this case, is interrupted at 1-second intervals, time interval readings can only be made at a one-per-second rate. The reading rate when comparison is made to a cw station such as WWVL is limited only by the sample rate and speed of the measurement and recording system.

Calculation of the frequency error of the local standard can be made as described in section III and is based upon the time drift of the average time interval readings.

D. USING AN OSCILLOSCOPE. Figure 2-2 (method B) shows an inexpensive system which can be used to compare secondary frequency standards, counter time base oscillators, and signal generators against lf/vlf signals.

The lf/vlf signal is received and amplified through a suitable receiver, such as the Dymec Model 5842, and displayed on the vertical axis of the oscilloscope. The oscilloscope is synchronized externally from the output, or divided output (note alternative system) of the standard under comparison. The lf/vlf signal must be a whole multiple of the signal used to trigger the oscilloscope sweep.

Comparison measurements are made by positioning the zero crossing of the waveform to some reference point on the oscilloscope and observing the amount and direction of drift over a period of time. A drift toward the right of the screen would indicate that the frequency of the local standard is high, whereas a drift to the left indicates a frequency that is too low. Average frequency error may be calculated from the following relationship:

$$\frac{\Delta f}{f} = \frac{\Delta t}{T}$$

where Δf = average frequency error

f = frequency to be calibrated

Δt = amount of drift during period T

T = comparison period.

Care must be taken when observing interrupted cw broadcasts (e.g., NBA) that noise during the "off" time of the signal* is distinguished from the "on" portion of the signal. This noise as present in the receiver output is sinusoidal, approximately the

same frequency as the carrier signal, and can be of sufficient amplitude to cause possible confusion.

Comparison accuracy of this technique is determined by oscilloscope trigger stability, sweep calibration accuracy, and the user's ability to integrate and resolve Δt . It is not recommended that frequency standards with accuracy requirements better than several parts in 10^9 be calibrated by this method.

E. DYMEC MODEL 5842-M1 RECEIVER. The Dymec Model 5842-M1 VLF Receiver incorporates a time comparator assembly and is designed to make comparisons with WWVL, without need of a separate frequency divider or time interval counter.

As shown in figure 2-2 (method C), the 100-kc signal from the local standard under test is divided by a 5:1 divider to 20 kc. The phase of this signal is compared to the 20-kc carrier of WWVL by means of a unique electronic phase comparator which gives an output directly proportional to the phase difference between the two 20-kc signals. This proportional voltage (50 μ sec = full scale) is available, after suitable integration, at the output to drive a potentiometer type strip chart recorder.

This system is designed for comparison with the 20-kc cw carrier of WWVL only, and provides a convenient, automatic, and continuous comparison record. Calculation of the frequency error of the local standard is described in section III.

The M1 conversion kit is available for field installation on the Model 5842 receiver or may be purchased installed in the Dymec Model 5842-M1. For further information, write: Dymec, 395 Page Mill Road, Palo Alto, California.

F. VLF PHASE TRACKING SYSTEM. The purpose of this type of receiver-comparator, as with the systems discussed above, is to measure the relative phase difference between standard broadcast vlf carriers and a locally-generated frequency. The Dymec Model 2365A VLF Phase Comparator, as shown in the simplified block diagram figure 2-2, method D, consists of a high sensitivity super-heterodyne receiver, a phase comparator, and a servo mechanism coupled in a closed loop to a phase shifter. The phase comparator generates the controlling signal for the servo mechanism based on the system phase relationship between a received vlf carrier and the local standard signal so as to null out the error detected in the phase comparator. This motion is transduced to provide a chart record for purposes of local standard frequency error calculation and calibration.

Vlf systems of this type have the advantage of being complete in themselves. No auxiliary measurement equipment is required. In addition, they are capable of providing phase comparison records from modulated vlf signals or from interrupted cw transmissions. The phase comparator and servo mechanism loop are arranged so that the servo mechanism will not drive in the absence of a suitable carrier level.

* Caused primarily by circuit ringing in narrow band, high gain receivers.

The overall system bandwidth of this type of receiver-comparator is determined primarily by the servo system time constant. In the case of the Dymec Model 2365A Phase Comparator, this time constant will be about 30 seconds, giving an equivalent bandwidth of approximately 0.005 cps. The 2365A has a receiver rf bandwidth of approximately 400 cycles and an IF bandwidth of about 80 cycles at 3 db down.

Good pulse reproduction through the receiver for obtaining time of day information from present vlf transmissions requires a bandwidth of about 400 cps

to the point of the 1 kc IF output. In the Dymec Model 2365A VLF Phase Comparator no narrow band filters are introduced until full IF gain has been achieved. At this point the 1 kc IF signal is taken from the signal channel to provide a coherent time tick to a monitor output jack. After this point, narrow band filters are introduced to provide adjacent channel rejection and noise reduction.

The Dymec 2365A tunes the entire 14 to 30 kc vlf band with self-contained synthesizer circuits permitting comparisons to be made at every integral 100 cps.

SECTION III FREQUENCY DETERMINATION

3-1. DIRECT COMPUTATION METHOD.

Two time comparisons are required to compute the average oscillator frequency (or average frequency error) during the time interval between readings. Since precision oscillators have a nearly constant drift rate, average frequency during a single time interval can be considered equal to the instantaneous frequency at the midpoint of the interval. Frequency calculations can be plotted graphically as shown in figure 3-2, to help estimate oscillator frequency at any given time.

Average fractional error in frequency is equal to the fractional time error and is given by

$$\frac{\Delta f}{f} = \frac{t_2 - t_1}{T}$$

where $\frac{\Delta f}{f}$ = average frequency error

t_1 = initial time-comparison reading

t_2 = final time-comparison reading

T = elapsed time between readings.

Example: Time comparison reading at 10:00 AM on June 1 is 563,060 microseconds; reading at 10:00 AM on June 4 is 564,040 microseconds. In this case,

$$\frac{\Delta f}{f} = \frac{564,040 \mu s - 563,060 \mu s}{3 \text{ days}} \times \frac{1 \text{ day}}{8.64 \times 10^{10}} = \frac{+3.8}{10^9}$$

That is, the average oscillator error during the period 10:00 AM on June 1 to 10:00 AM on June 4 (or, assuming constant frequency drift, the instantaneous error at 10:00PM on June 2) is 3.8 parts in 10^9 high.

Average frequency of an oscillator during the measurement interval is given by

$$f_{av} = f_{nom} \left(1 + \frac{\Delta f}{f} \right)$$

where f_{av} = average frequency

f_{nom} = nominal oscillator frequency

$\frac{\Delta f}{f}$ = average frequency error.

Continuing with the example given above for an oscillator with a nominal frequency of 1 mc,

$$f_{av} = 10^6 \left(1 + \frac{3.8}{10^9} \right) = 1,000,000.0038 \text{ cps}$$

3-2. SLOPE OF TIME-ERROR CURVE METHOD.

Time-comparison measurements may be plotted directly (figure 3-1), thus eliminating the routine of daily frequency error computation. The slope of the time-error curve equals the instantaneous oscillator frequency error at that time.

To find oscillator frequency error, draw a smooth curve through the daily time-comparison plots. Draw a line tangent to the curve at the time for which the instantaneous frequency is required. Choose a convenient segment of the tangent line and divide its time error (projection on the TIME REFERENCE scale) by its elapsed time (projection on the ELAPSED TIME scale). The quotient (using the relationship 8.64×10^{10} microseconds = 1 day to cancel units of measurement) is the oscillator frequency error.

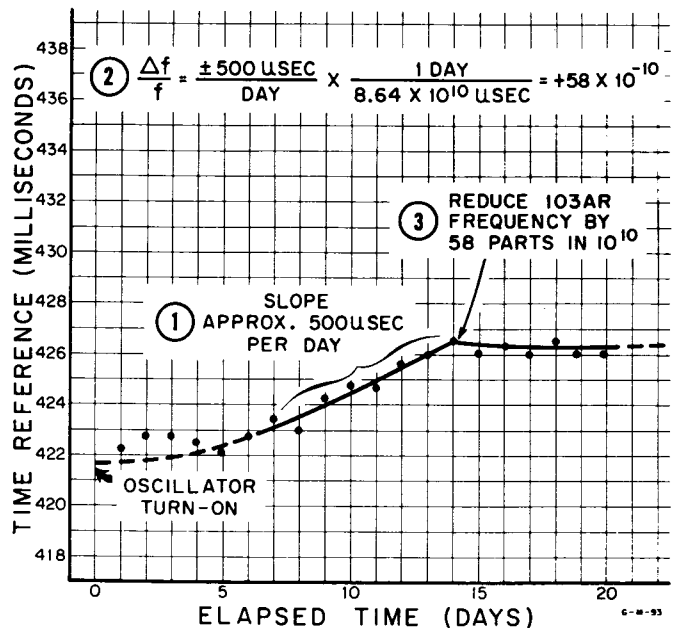

Figure 3-1. Time Comparison Plot

Time-comparison measurements permit determination of average oscillator error during a time interval which has already occurred. Present and future frequency error can be estimated graphically by extrapolation.

A simple technique can be used with the time curve to maintain oscillator frequency within specified limits. Determine the slope which represents maximum allowable oscillator error. When the time-error curve reaches this slope, readjust oscillator frequency accordingly. See figure 3-3.

DAY	TIME REFERENCE	
	MILLISEC	MICROSEC
0	293	700
7	290	680
14	290	680
28	292	190
35	295	810

$$\frac{\Delta f}{f} = \frac{(t_2 - t_1) \text{ USEC}}{T \text{ DAYS}} \times \frac{1 \text{ DAY}}{8.64 \times 10^{10} \text{ USEC}}$$

FINAL TIME COMPARISON READING (points to t_2)
 INITIAL TIME COMPARISON READING (points to t_1)
 ELAPSED TIME BETWEEN COMPARISON READINGS (points to T)
 NUMBER OF MICROSECONDS IN ONE DAY (points to 8.64×10^{10})
 FREQ. ERROR (points to $\frac{\Delta f}{f}$)

A FREQ. ERROR FIRST WEEK

$$\frac{\Delta f}{f} = \frac{(290\ 680 - 293\ 700) \text{ USEC}}{7 \text{ DAYS}} \times \frac{1 \text{ DAY}}{(8.64 \times 10^{10}) \text{ USEC}} = -50 \times 10^{-10}$$

B FREQ. ERROR SECOND WEEK

$$\frac{\Delta f}{f} = \frac{290\ 680 - 290\ 680}{7} \times \frac{1}{8.64 \times 10^{10}} = 0$$

C FREQ. ERROR THIRD WEEK

$$\frac{\Delta f}{f} = \frac{292\ 190 - 290\ 680}{7} \times \frac{1}{8.64 \times 10^{10}} = +25 \times 10^{-10}$$

D FREQ. ERROR FOURTH WEEK

$$\frac{\Delta f}{f} = \frac{295\ 810 - 292\ 190}{7} \times \frac{1}{8.64 \times 10^{10}} = +60 \times 10^{-10}$$

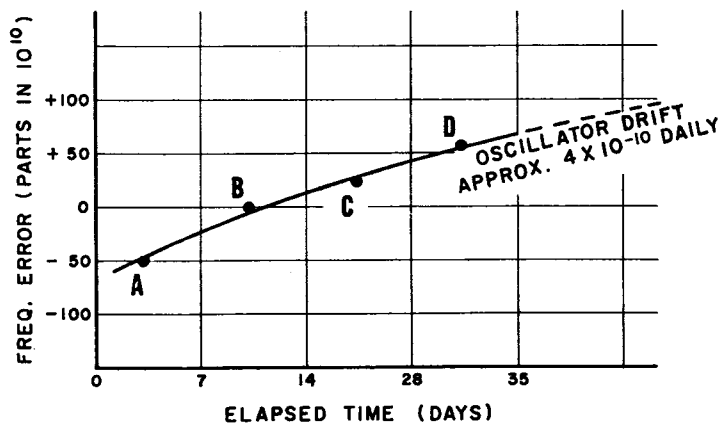

Figure 3-2. Direct Frequency Plot

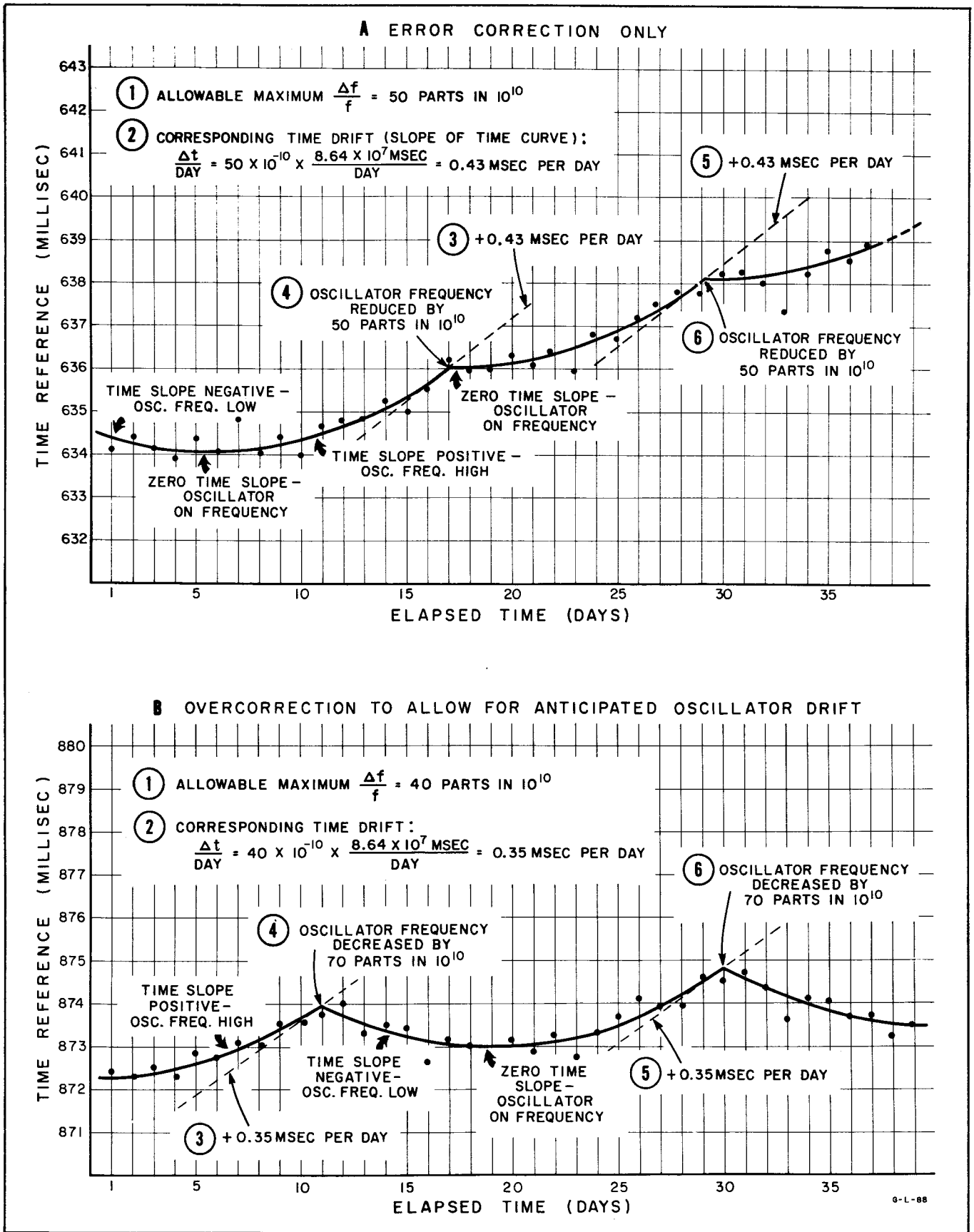

Figure 3-3. Slope-Limit Frequency Control

Inspection of the shape of the time curve can quickly give information on the general nature of oscillator behavior. For example, a parabolic time curve which is concave as viewed from the top indicates positive and linear drift of oscillator frequency. The vertex of the parabola corresponds to zero oscillator error. See figure 3-4.

3-3. COMPARISON AGAINST VLF.

An analog plot is made of the time interval between the local oscillator and the vlf signal as described in section II. From this record, the drift rates may be accurately and quickly determined. Figure 3-5 is a strip chart recording of a typical vlf comparison of a local standard with respect to WWVL (received at Palo Alto, California). Here we see a change in the average value of the time interval measurements of 4 microseconds over a period of two hours. This corresponds to a frequency offset in the local standard of

$$\frac{\Delta f}{f} = \frac{\Delta t}{T} = \frac{4 \mu s}{7.2 \times 10^9} \approx 5 \text{ parts in } 10^{10}$$

The large pips are the result of WWVL identification modulation, spaced 20 minutes apart. Chart speed is 7-1/2 inches per hour.

The following graphs (figure 3-7) were derived from frequency comparisons of an Model 103AR Quartz Oscillator against WWVL. Time interval can be read directly in microseconds by using the vertical scale numbers (10 μs = 1 cm). These graphs were not actually made on consecutive days, but were chosen to demonstrate typical slopes and noise conditions.

From the example in table 3-1 the relationship between WWVL and the local standard may be determined. Hypothetical WWVL/USFS offsets are given. Assume that the local standard is properly calibrated when offset from the USFS by -150×10^{-10} , since this is the amount that UT2 was offset for 1960-1961 from USFS (see appendix II, paragraph 3).

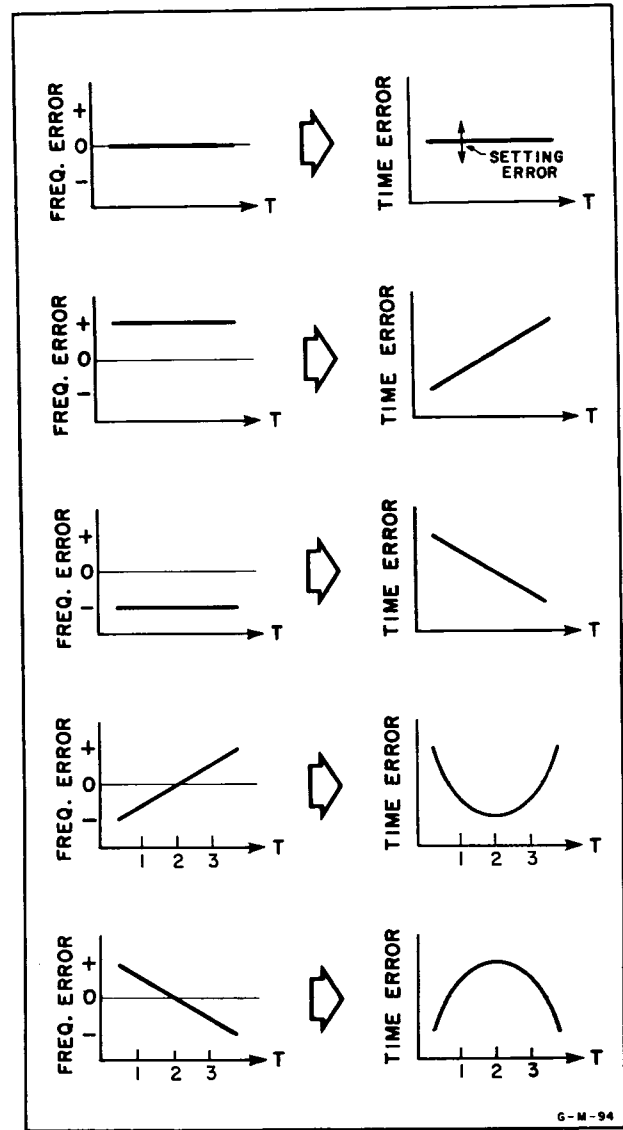

Figure 3-4. Corresponding Frequency and Time Curves

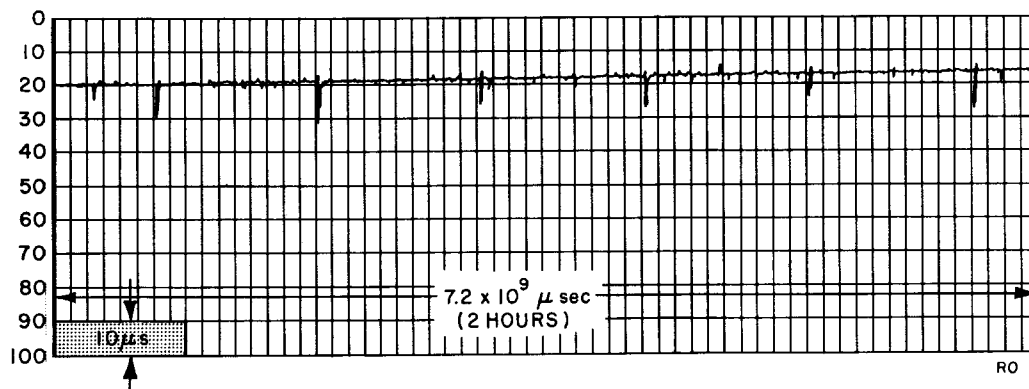

Figure 3-5. Strip-Chart Recording of VLF Frequency Comparison Using WWVL Over Two Hour Period

Table 3-1. Equivalents

Day	WWVL/USFS Offset (x10 ⁻¹⁰)	103AR/WWVL ($\Delta t \times 10^{-10}$)	103AR/USFS Offset (x10 ⁻¹⁰)	103AR Xtal Freq. (cps)
1	-153	+0.7	-152.3	999,999.99977
2	-148	-8.2	-156.2	999,999.99938
3	-144	-9.1	-152.1	999,999.99979
4	-145	-9.8	-153.8	999,999.99962
5	-151	+1.4	-149.6	1,000,000.00004
6	-148	-2.8	-150.8	999,999.99992
7	-151	+1.4	-149.6	1,000,000.00004

Plotting the data in table 3-1 to obtain figure 3-6, we can determine the average frequency drift of the local standard, which is approximately 0.8×10^{-10} per day in this example.

The absolute accuracy of the oscillator thus calibrated is dependent upon the absolute accuracy of the standard time signal, in addition to the accuracy of comparison. Furthermore, the stability of the local standard will be a large factor in determining how frequently calibration measurements should be made and to what accuracy the absolute value of the frequency can be set.

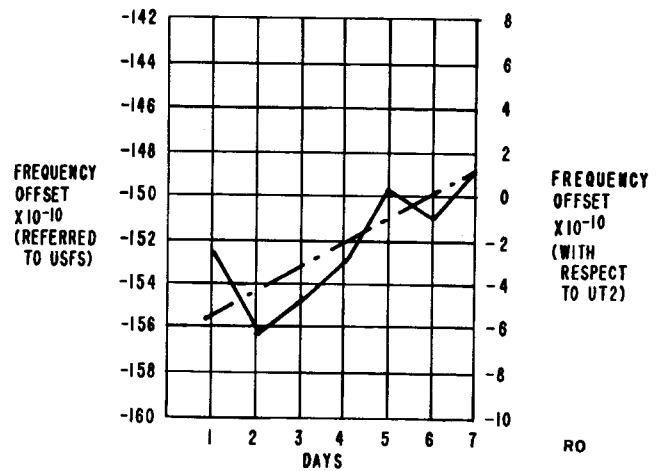

Figure 3-6. Plot of Local Standard's Average Frequency Drift

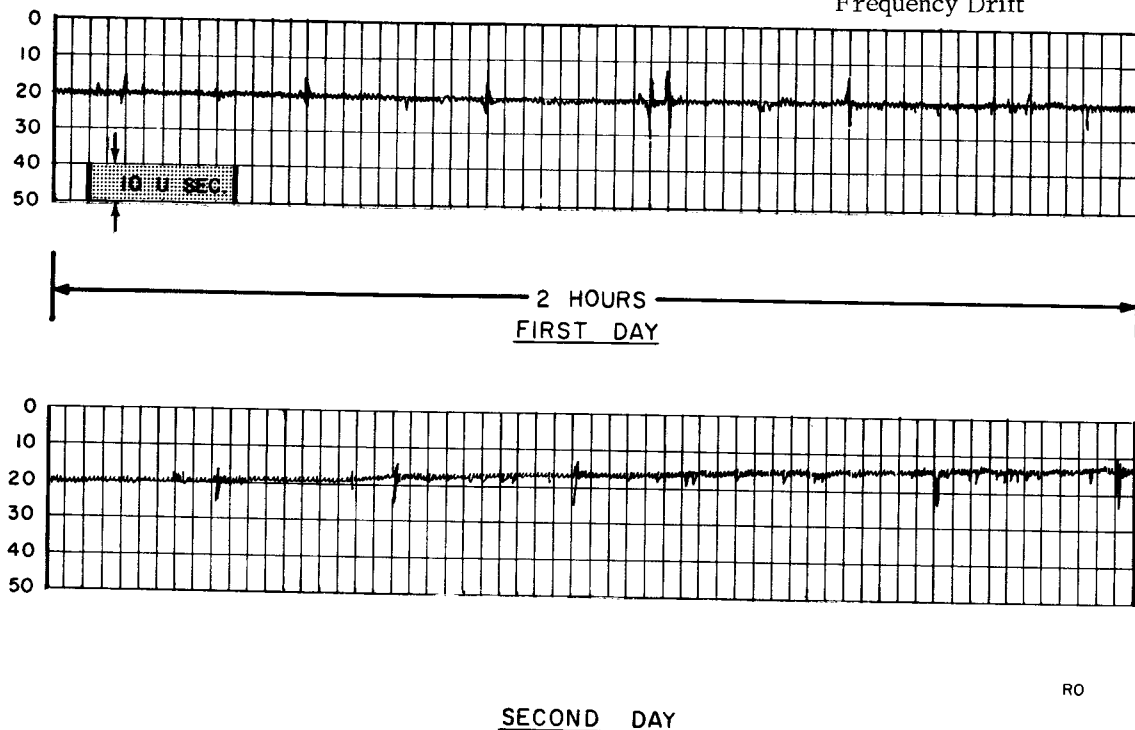
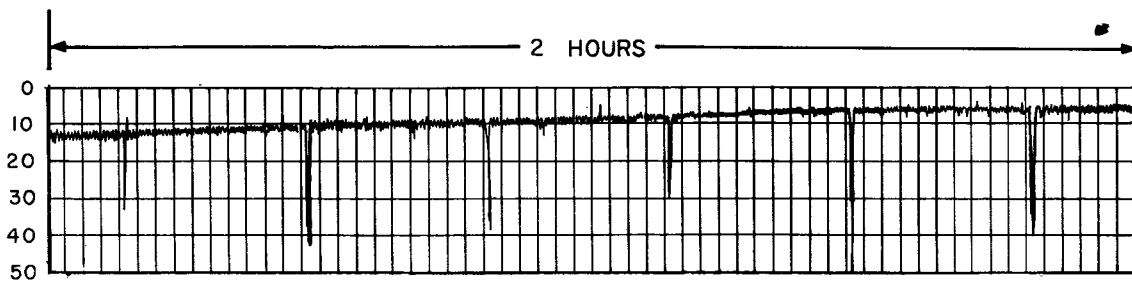
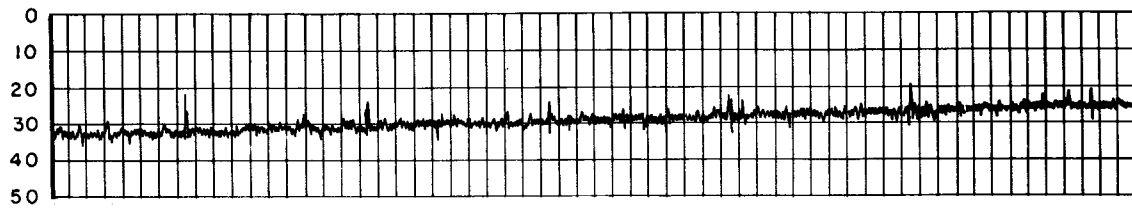

Figure 3-7. Seven Day Derived Frequency Comparisons between Φ Model 103AR Quartz Oscillator and WWLV (Sheet 1 of 2)



THIRD DAY



FOURTH DAY

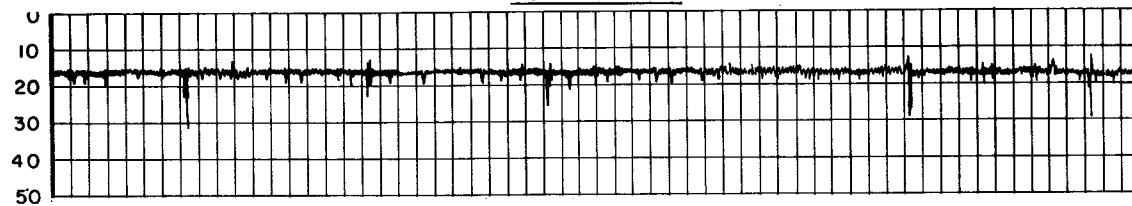

FIFTH DAY

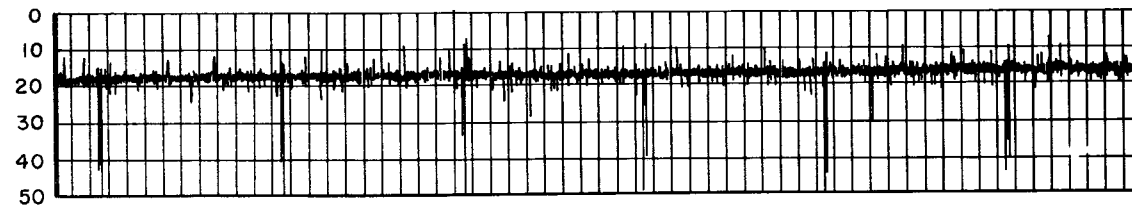

SIXTH DAY

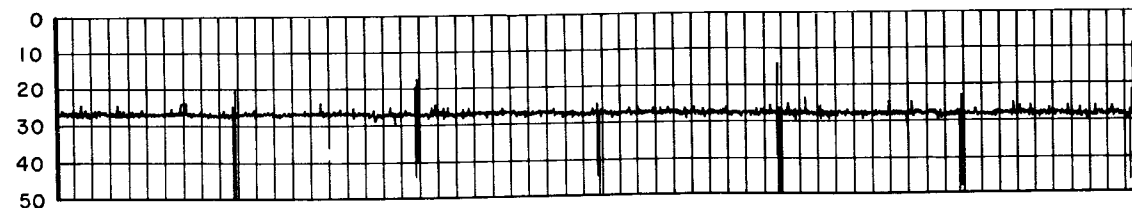

SEVENTH DAY

RO

Figure 3-7. Seven Day Derived Frequency Comparisons
between Model 103AR Quartz Oscillator and WWLV (Sheet 2 of 2)

SECTION IV TIME DETERMINATION

4-1. INTRODUCTION.

Accurate timekeeping depends upon (a) understanding oscillator behavior and (b) accurate time synchronization with a master timing source. Oscillator behavior, i.e., drift rate and change in drift rate, can be determined by inspecting the frequency or time plots described in paragraph 4-6. Absolute synchronization between two or more clocks presents a problem which has been solved in several ways:

A. TRANSPORTING A MASTER CLOCK. Time synchronization accuracy to about ± 1 microsecond or less can be made by transporting a master clock to each clock station. Achieved accuracy depends largely upon the comparison method. The rate (i.e. the daily time gain or loss) and acceleration (i.e. the change in rate) of the master clock must be accurately known and an appropriate correction must be made at each clock station.

B. TWO-WAY RADIO TRANSMISSION. Time synchronization accuracy as good as ± 10 microseconds can be made using a transponder at the clock station. The propagation delay which the timing pulse undergoes between the master transmitter and the clock station can be accurately determined at the master transmitter from the following relationship:

$$t_{prop} = \frac{t_{tot} - t_{tr}}{2}$$

where t_{prop} = one-way propagation delay between master transmitter and clock station

t_{tot} = total delay at master transmitter between transmission of timing signal and receipt of transponder signal

t_{tr} = delay at the transponder between receipt of timing signal and retransmission of the signal.

Time synchronization by this method requires special transmitting and receiving equipment at both the master time source and the station requiring synchronization and is therefore impractical for most time standard systems.

C. ONE-WAY HF RADIO TRANSMISSION. Time synchronization accuracy to ± 1 millisecond or less can be made using presently available standard time signals such as those transmitted by station WWV. With this method the propagation delay between the transmitter and clock station must be determined and then applied as a correction to the clock reading.

The principal factors which affect the propagation delay for hf signals are (a) the great circle distance between transmitter and receiver, (b) the transmission mode (i.e. the number of earth-to-ionosphere reflections between transmitter and receiver), and (c) the virtual height of the ionospheric reflection layers. A detailed discussion of distance determination is given in paragraph 4-2, transmission mode estimation in paragraph 4-3, layer height estimation in paragraph 4-4, and delay determination by graphic means in paragraph 4-5.

Once the propagation delay has been determined, the time reference control on the clock can be positioned to allow for the delay. The 1-second clock ticks are then produced in synchronism with the transmitted master timing signal.

Example: A clock station (using oscillator-clock-oscilloscope system) located 3100 kilometers (about 10.80 milliseconds transmission delay) from WWV is required to synchronize its clock ticks with the WWV ticks as transmitted. Time-comparison readings are taken when the zero crossing of the second cycle of the received WWV tick is aligned with the vertical center-line of the crt (1 millisecond per centimeter sweep speed); the leading edge of the received WWV tick therefore occurs 4 milliseconds after the clock tick (which triggers the oscilloscope). Inspection of the smoothed curve on the time-comparison graph shows that for a particular day, the time reference control on the clock should be set to 231,770 microseconds for clock-tick coincidence with the received WWV tick. The time reference setting for synchronization with the transmitted WWV ticks on this day is determined as follows:

Time-comparison graph	231,770 μ sec
Reading correction	+ 4,000
Transmission delay	<u>-10,800</u>
Final dial setting	224,970 μ sec

D. ONE-WAY LF/VLF RADIO TRANSMISSION. In addition to the hf time signal services discussed above, there are several vlf and lf stations that broadcast time of day information. In fact, NBA at the Panama Canal Zone and GBR and MSF at Rugby, England (see table 1-3 for additional information) are now coordinating their time signals with WWV and WWVH for purposes of world-wide time synchronization. The time ticks from these stations are maintained to within 0.5 to 1 millisecond of each other

on the UT2 time scale. The frequency offset of this carrier is kept as close as possible to 150 parts in 10^{10} below ephemeris frequency.

These lf/vlf standard broadcasts may therefore be used in much the same way as hf standard broadcasts to set and maintain local time. Once time is set, these lower frequency transmissions offer the user the advantage of very precise frequency control over the clock oscillator. As explained in paragraph 1-3, the accuracy of frequency transfer by vlf may be as good as a very few parts in 10^{11} in one day as compared to parts in 10^9 for hf. Accurate time synchronization, of course, depends upon both the ability to set time locally and to maintain highly accurate control over the clock oscillator.

The principle limitation in the use of lf/vlf for time of day has to do with system bandwidth considerations. Time pulses are shaped by the relatively high Q's of the transmitter and receiver facilities so that a high degree of resolution on time of day measurements is more difficult than with hf. Furthermore, different low frequency wavelengths propagate with different phase velocities. This causes dispersion of modulated vlf signals that distorts time pulses and places another limitation on the ability to accurately calibrate local clocks.

With the present lf/vlf time services and the receiving equipment now available, time synchronization can probably be accomplished to no better than a few milliseconds. This is somewhat poorer than is the case for hf where careful technique can yield time accuracies of 1 millisecond or less. The actual calculations for time of day from lf/vlf time ticks must include the factors of propagation and receiving systems delay in the same way as with lf, except for the simplification made possible by the assumption of all ground-wave transmissions for lf/vlf. VLF waves propagate at about 292,000 km/sec as compared to 278,000 km/sec for hf waves.

Since lf and vlf transmissions are propagated for relatively great distances by ground wave, propagation delay for these frequencies can usually be found directly after computing the great circle distance.

Other methods than the single-carrier, time tick kind of time of day transmissions are being considered in an attempt to improve the accuracy of time synchronization from lf/vlf. None of these are presently in use, and it does not seem likely that any significant changes will be made in the near future.

4-2. GREAT-CIRCLE DISTANCE.

The great circle distance between points A and B whose latitude and longitude are known can be rapidly determined from the following relationship (see figure 4-1):

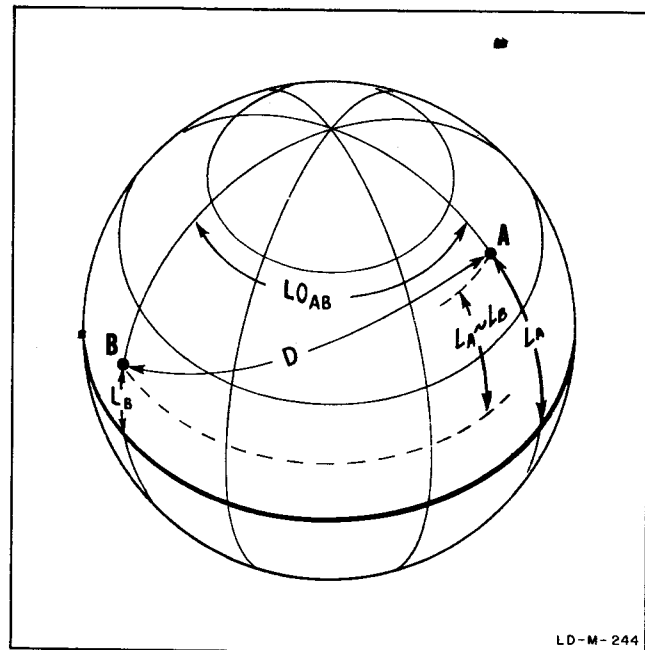

Figure 4-1. Great Circle Distance Calculation

$$\text{hav } D = \cos L_A \cos L_B \text{ hav } L_{O_{AB}} + \text{hav } (L_A \sim L_B)$$

where D = great circle distance A to B expressed in degrees of arc

L_A = latitude of A

L_B = latitude of B

$L_{O_{AB}}$ = difference of longitude between A and B

$(L_A \sim L_B)$ = the difference of L_A and L_B if A and B are on the same side of the equator or the sum of L_A and L_B if A and B are on opposite sides of the equator.

Note: The haversine of angle $\theta = 1/2$ versine $\theta = 1/2 (1 - \cos \theta) = \sin^2 1/2 \theta$; also, $\text{hav } \theta = \text{hav } (360^\circ - \theta)$; thus, $\text{hav } 210^\circ = \text{hav } 150^\circ$.

Computations made using haversine and cosine table in appendix III are sufficiently accurate for most sky-wave propagation delay estimates. Distance errors of as much as 10 to 20 miles contribute less error to the delay estimate than is expected to result from errors in estimating propagation mode and ionospheric height. A more extensive haversine table permitting distance calculation to within a mile, is given in Bowditch, American Practical Navigator, Part II, U.S. Government Printing Office, Washington 25, D. C.

Example: Find the distance between radio station WWV (point A), $39^\circ 00' N$ $76^\circ 51' W$, and Palo Alto, California (point B), $37^\circ 23' N$ $122^\circ 09' W$.

$$L_A = 39^{\circ}00'N$$

$$L_B = 37^{\circ}00'N$$

$$Lo_{AB} = 45^{\circ}18'$$

$$L_A \sim L_B = 1^{\circ}37'$$

$$\log \cos L_A = \log \cos 39^{\circ}00' = 9.8905 - 10$$

$$\log \cos L_B = \log \cos 37^{\circ}23' = 9.9001 - 10$$

$$\log \text{hav } Lo_{AB} = \log \text{hav } 45^{\circ}18' = 9.1712 - 10$$

$$\hline 8.9618 - 10$$

Taking antilog from haversine table, log hav to nat hav:

$$\text{antilog } 8.9618 - 10 = 0.0916$$

$$\text{hav } (L_A \sim L_B) = \text{hav } 1^{\circ}37' = \frac{0.0002}{0.0918}$$

$$D = \text{arc hav } 0.0918 = 35^{\circ}17'$$

Since 1' of arc = 1 nautical mile = 1.151 statute miles = 1.853 kilometers, then $35^{\circ}17'$ = 2117 nautical miles = 2439 statute miles = 3923 kilometers.

4-3. TRANSMISSION MODE.

The ground-wave propagation path (most lf/vlf transmissions and short-distance hf transmissions) closely follows the great-circle route between the transmitter and receiver. However, hf transmissions over a distance of more than about 160 kilometers follow sky-wave paths.

The maximum distance that can be spanned by a single hop (i.e., one reflection from the ionosphere) via the F2 layer is about 4000 kilometers (figure 4-2). Therefore, the fewest number of hops between transmitter

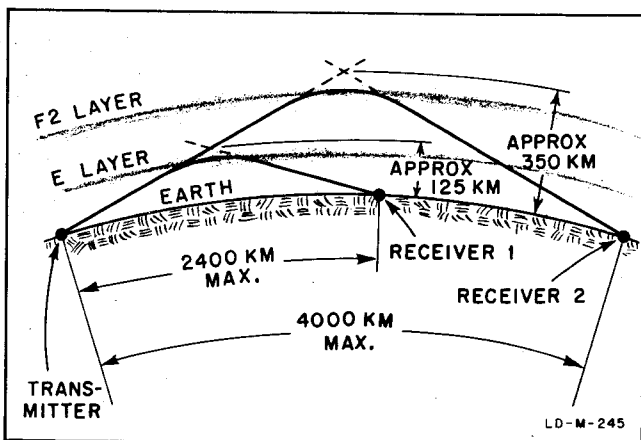

Figure 4-2. Single-Hop Sky-Wave Paths

and receiver is the next integer greater than the great-circle distance (in kilometers) divided by 4000. Transmission modes with one or two more hops than the minimum number of hops occur frequently (figure 4-3), but modes of higher order are greatly attenuated during transmission and are of little concern.

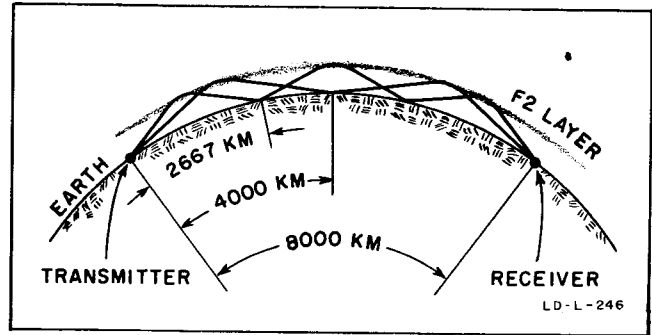

Figure 4-3. Multiple-Hop Transmission Path

Example 1: Find the minimum number of hops for a distance of 3923 kilometers.

Solution: A one-hop F2 mode is possible ($3923 \div 4000 < 1$).

Example 2: What modes are likely to be received at a distance of 7687 kilometers?

Solution: Two-hop, three-hop, and four-hop F2 modes can be expected ($7687 \div 4000 > 1$, but < 2).

Useful transmissions via the E layer (daytime only) are usually limited to one-hop modes up to a distance of about 2400 kilometers.

Remember that some locations may receive transmissions from both the E and F2 layers and that transmissions may be reflected occasionally from layers other than the E and F2.

The following approach should improve your estimate of propagation delay:

- 1) Determine which modes are possible at your location.
- 2) Tune to the highest frequency which provides consistent reception to reduce interference from high-order modes.
- 3) If several modes are being received (indicated by multiple tick reception or tick jitter between fairly constant positions), select the tick with earliest arrival time for measurements.
- 4) After plotting time measurements for several weeks, either disregard measurements which are conspicuously out of place, or correct the measurement to the more likely mode if the plot is mistimed by the difference in time between possible modes.

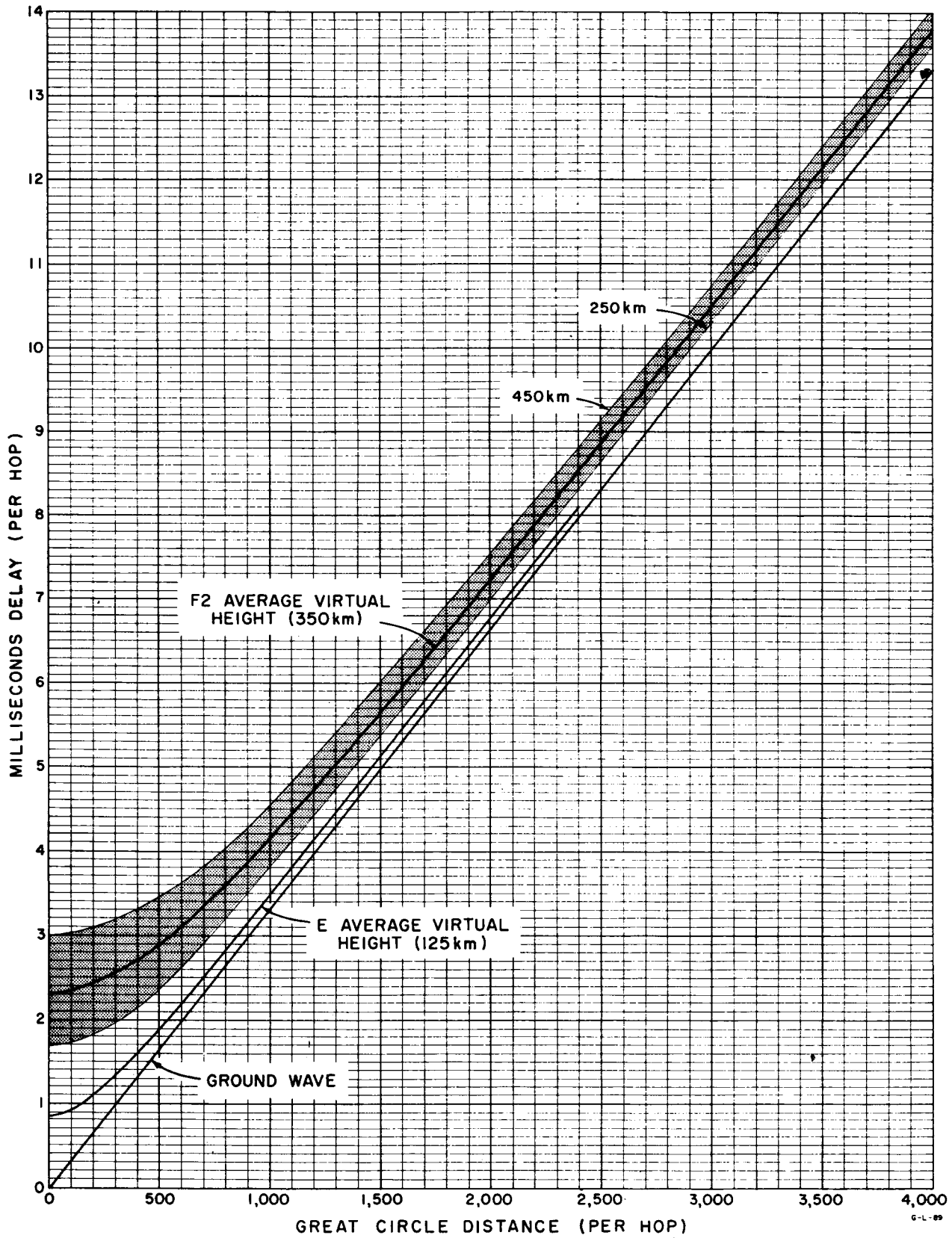

FROM A.H. MORGAN, TIME SYNCHRONIZATION
OF WIDELY SEPARATED CLOCKS.

Figure 4-4. Transmission Delay Graph

4-4. HEIGHT OF IONOSPHERE.

Long-distance hf transmissions are usually reflected from the F2 layer, which varies in height from about 250 to 450 kilometers. Experience has shown that the virtual height of the F2 layer averages about 350 kilometers (figure 4-2). Unless special studies permit determination of layer height at the point of 350 kilometers can be used for delay estimation.

The E layer exists only during the daytime at a virtual height of about 125 kilometers (figure 4-2). One-hop E modes may provide very steady daytime reception at distances up to about 2400 kilometers.

4-5. DELAY DETERMINATION.

Once the transmitter-to-receiver distance, possible transmission modes, and layer heights have been determined, transmission delay can be found graphically from figure 4-4. The shaded area along the F2 curve shows the possible extremes of height variation.

As shown in the following examples, the delay for a one-hop mode can be read directly from the transmission delay graph for a given distance and layer height.

Example 1: Find the one-hop delay for a distance of 3923 kilometers.

Solution: Expected F2 delay is about 13.60 milliseconds. No one-hop E mode is likely since the distance is greater than the usual limit of 2400 kilometers for the one-hop E mode.

Example 2: Find the one-hop delay for a distance of 2200 kilometers.

Solution: Expected F2 delay is about 7.90 milliseconds; expected E delay is about 7.50 milliseconds.

For a multi-hop mode, (a) determine the distance covered by each hop, (b) find the delay for a single hop, then (c) multiply the single-hop delay by the number of hops to determine the total delay.

Example 3: Find the two-hop delay for a distance of 3923 kilometers.

Solution: Each 1962-kilometer hop contributes a delay of about 7.15 milliseconds; the total delay is 7.15 x 2 or 14.30 milliseconds. Note that the two-hop delay for a 3923-kilometer distance is 0.7 millisecond greater than the one-hop delay for the same distance determined in example 1 above.

Example 4: Find the three-hop delay for a distance of 7687 kilometers.

Solution: The delay contributed by each 2562-kilometer hop is about 9.05 milliseconds; the total delay is 0.05 x 3 or 27.15 milliseconds.

Example 5: Find the four-hop delay for a distance of 7687 kilometers.

Solution: The delay contributed by each 1922-kilometer hop is about 6.95 milliseconds; the total delay is 6.95 x 4 or 27.80 milliseconds. Note that the four-hop delay for 7687-kilometer distance is 0.65 milliseconds greater than the three-hop delay for the same distance determined in example above.

4-6. EFFECT OF FREQUENCY DRIFT ON THE ACCUMULATION OF TIME ERRORS.

PROBLEM:

Assume it is necessary to maintain a time system to within 10 milliseconds. Determine the maximum number of days that the oscillator operating this system may be left untouched if it exhibits a constant, positive drift rate of 5×10^{-10} parts per day.

SOLUTION:

Let E_t = the error at time t

f_t = the frequency at time t

f_o = the frequency at time t_o

f_r = the design or reference frequency of the system (i.e. 1 mc)

a = the frequency drift rate

When we say that a frequency drift, a , is 5×10^{-10} parts per day, we assume that the frequency shift is a straight line. The frequency can be expressed:

$$f_t = f_o + af_r t$$

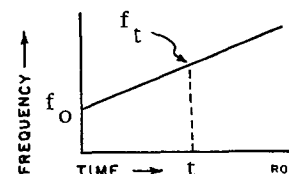

Since f_t is not equal to the reference frequency, each cycle is a little too long or too short and the system loses or gains time. The gain in time per cycle = $(1/f_r - 1/f_t)$. In an arbitrarily small time Δt , there

are $f_t \Delta t$ cycles and the gain in time or incremental error ΔE can be expressed as the gain per cycle times the number of cycles.

$$\Delta E = \left(\frac{1}{f_r} - \frac{1}{f_t} \right) f_t \Delta t$$

Taking the limit as $\Delta t \rightarrow 0$

$$\begin{aligned} dE &= \left(\frac{1}{f_r} - \frac{1}{f_t} \right) f_t dt \\ &= \left(\frac{f_t}{f_r} - 1 \right) dt \end{aligned}$$

Integrating, to find E

$$E = \int \left(\frac{f_t}{f_r} - 1 \right) dt$$

$$E = \int \frac{f_t}{f_r} dt - \int dt$$

$$= \int \frac{(f_0 + af_r t)}{f_r} dt - \int dt$$

$$= \frac{f_0}{f_r} t + \frac{at^2}{2} - t + \text{constant}$$

$$= \frac{f_0}{f_r} t + \frac{at^2}{2} - t + \text{constant}$$

Setting $t = 0$ we see that the constant is the initial error which we will call E_0 .

Rearranging terms, we have the general equation

$$E = E_0 + \left(\frac{f_0}{f_r} - 1 \right) t + \frac{at^2}{2} \quad (1)$$

Equation (1) indicates that the total time error at any time is a function of four things:

1. The initial time error, E_0
2. The initial frequency, f_0
3. The drift rate, a
4. The elapsed time, t .

If we plot equation (1) we find it is a parabola: (vertical displacement of error curves below depends on initial value of E_0).

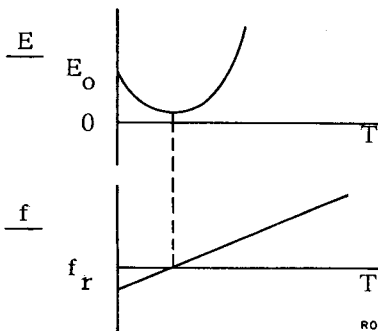

Graph of equation (1) for "a" positive (positive drift rate)

Corresponding frequency plot.

If the frequency drift is negative, the parabola is inverted. Note that the slope of the error curve is zero when the oscillator frequency is equal to the reference frequency, f_r .

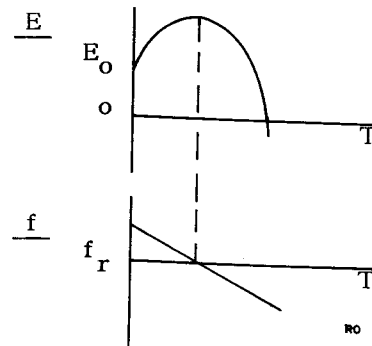

Or, if the frequency drift is positive and starts off equal to f_r

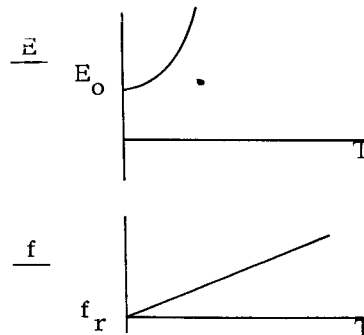

Now, going back to our specific problem, we will maximize the time that the error is less than 10 milliseconds if we choose the initial condition so that the curve looks like this:

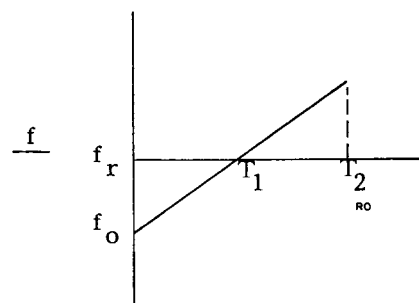
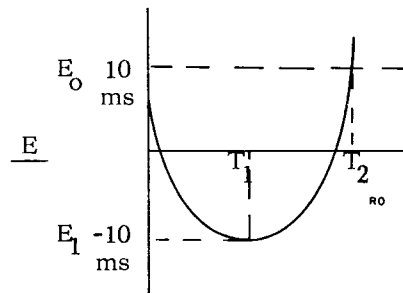

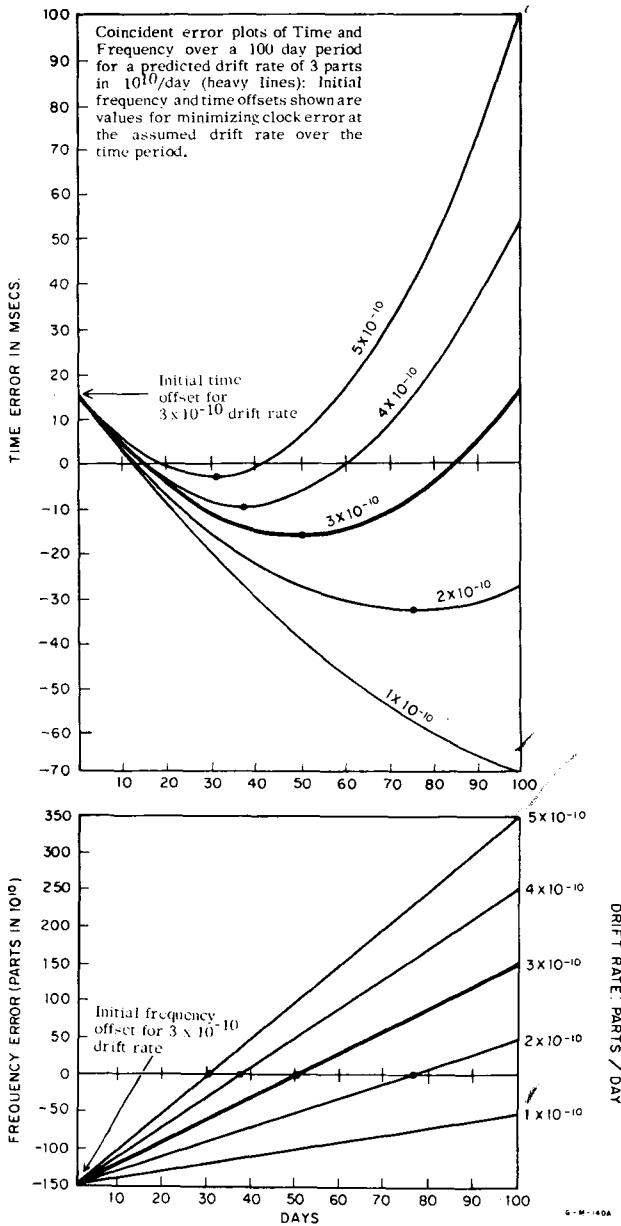

Figure 4-5. Drift Rate Plots

First, let's examine t_1 . We can write an expression for E_1 from equation (1)

$$E_1 = E_0 + \left(\frac{f_0}{f_r} - 1\right) t_1 + \frac{at_1^2}{2}$$

But we note at t_1 :

$$E_1 = -E_0$$

$$-E_0 = E_0 + \left(\frac{f_0}{f_r} - 1\right) t_1 + \frac{at_1^2}{2}$$

$$0 = 2E_0 + \left(\frac{f_0}{f_r} - 1\right) t_1 + \frac{at_1^2}{2} \quad (a)$$

This equation has two unknowns: f_0 and t_1 . Therefore, let's look for another equation relating these unknowns. Note that at t_1 the slope of time curve is zero.

Expressing this mathematically: $\frac{dE}{dt} = 0$

Differentiating equation (1): $\frac{dE}{dt} = \left(\frac{f_0}{f_r} - 1\right) + at$

Setting this equal to 0 at t_1 : $\left(\frac{f_0}{f_r} - 1\right) + at_1 = 0$

$$t_1 = -\frac{\left(\frac{f_0}{f_r} - 1\right)}{a} \quad (b)$$

Rewriting (b)

$$\left(\frac{f_0}{f_r} - 1\right) = -at_1 \quad (c)$$

Substituting (c) into (a) to eliminate f_0 or actually

$$\begin{aligned} &\left(\frac{f_0}{f_r} - 1\right) \\ 0 &= 2E_0 + (-at_1) t_1 + \frac{at_1^2}{2} \\ &= 2E_0 - at_1^2 + \frac{at_1^2}{2} \\ &= 2E_0 - \frac{at_1^2}{2} \\ t_1^2 &= \frac{4E_0}{2} \\ t_1 &= 2\sqrt{\frac{E_0}{a}} \quad (2) \end{aligned}$$

Since equation (1) is a parabola, symmetrical about t_1

$$t_2 = 2t_1$$

$$t_2 = 4\sqrt{\frac{E_0}{a}} \quad (3)$$

Substituting numbers

$$E_0 = 10 \text{ milliseconds} = \frac{10^{-7}}{.864} \text{ days}$$

$$t_2 = 4\sqrt{\frac{10^{-7}}{.864} \left(\frac{1}{5 \times 10^{-10}}\right)}$$

$$= 60.8 \text{ days.}$$

What would be the answer to the problem if the oscillator drift were only half as great, that is 2.5×10^{-10} parts per day?

Solution: From equation (3) t_2 is proportional to $\sqrt{\frac{1}{a}}$

In this problem "a" equals 1/2 "a" of the first problem. The answer equals the answer of the first problem times

$$\sqrt{\frac{1}{1/2}} = \text{answer} \times \sqrt{2}$$

$$t_2 = 60.8 \sqrt{2} = 86.0 \text{ days.}$$

In the first problem should the initial frequency f_0 be set high or low? If $f_r = 1 \text{ mc}$, what should the initial frequency be?

Solution: From equation (c)

$$\frac{f_0}{f_r} - 1 = at_1$$

$$f_0 = f_r (1 - at_1)$$

Substituting $t_1 = 2\sqrt{\frac{E_0}{a}}$

$$= f_r (1 - a2\sqrt{\frac{E_0}{a}})$$

$$= f_r (1 - 2\sqrt{aE_0})$$

$$= f_r \left[1 - 2\sqrt{(5 \times 10^{-10}) \left(\frac{10^{-7}}{.864}\right)} \right] = f_r - 152 \times 10^{-10}$$

that is, the initial frequency, f_0 , should be set low by 152 parts in 10^{10} .

It should be kept in mind that once a predicted drift rate has been established and the clock offset to minimize this error over a period of time, any drift rate other than this will create considerably more time error. This applies to drift rates less than that predicted, as well as those greater. This relationship is correlated in figure 4-5. In this example, predicted frequency drift is assumed to be 3×10^{-10} parts per day, illustrated graphically by the heavy solid line; therefore, the initial frequency is offset -150 parts in 10^{10} to minimize the error over the 100 day period. Drift is further assumed to be linear over this period. The initial time offset of approximately 16 milliseconds will minimize the effects of this predicted drift over the 100 day period.

The drift rate of 1,2,4, and 5 parts in 10^{10} are plotted to show how time error is affected when oscillator performance differs from that predicted after setup for minimum time error.

SECTION V

STABILITY AND SPECTRAL PURITY IN FREQUENCY STANDARDS *

5-1. INTRODUCTION.

The need for a frequency source having good long-term stability and capable of providing a pure signal in the microwave region has become more pressing. For instance, microwave spectroscopy and atomic frequency standards require stable, pure signals in order to excite transitions between various energy states. Communication systems giving good signal to noise ratios use extremely narrow bandwidths requiring stable, narrow band signals.

An excellent way to get these stable, pure microwave signals is by multiplying the output of a megacycle region frequency. The stability and spectral purity of the frequency standard output must be of high quality to obtain a good narrow spectrum after multiplication.

Some of the considerations and techniques involved in the design of a quartz oscillator which meets the requirements of spectral purity as well as long- and short-term stability are discussed here.

5-2. FACTORS AFFECTING LONG- AND SHORT-TERM STABILITY.

The quality and environment of the oscillator quartz crystal are the most important things in achieving good long-term stability. Modern AT cut resonators regularly show aging rates less than ± 5 parts in 10^{10} per day. To achieve this stability, power dissipated in the crystal by the oscillator must be very low and extremely constant. A typical figure for frequency change due to drive level change is about 10^{-9} per db at $1 \mu\text{w}$ drive level. For this reason, a high-performance AGC system is required, since, if power level changes with time, the frequency will also change with time and both long- and short-term stability will be degraded.

Since the resonant frequency of the quartz crystal will change if its operating temperature changes, the crystal must be housed in a good oven. Any aging effect which causes the oven temperature to change with time can be a source of long-term drift, which increases sharply with greater deviation of oven temperature from the crystal's zero coefficient temperature. In addition, frequency changes which result from any short-term variations in oven temperature represent decreased short-term stability. Precise control of oven temperature is therefore essential to stability--both long-term and short-term.

The elements in the oscillator directly associated with the crystal must have good long-term stability and in some cases, should be included in the oven along with the crystal. Such things as series capacitors, coarse tuning control and, if the oscillator is transistorized, the oscillator transistor itself are among these items.

Particular attention must also be given in designing the basic oscillator so the voltage coefficient of frequency will be low. In addition, supply voltages should be well regulated. Special care should be taken to minimize stray coupling and undesirable feedback which can introduce elements of very unstable phase angle and even cause changes in crystal power level.

5-3. TECHNIQUES FOR OBTAINING SPECTRAL PURITY.

Even a very crude oscillator will have a reasonably good spectrum at the frequency of oscillation. The spectrum rapidly degrades with frequency multiplication, however, so that it is necessary to start out with an extremely good spectrum in order to have a good one when multiplying up to the microwave region.

If the frequency multipliers used are broadband, an expression for the spectrum of the multiplied signal may be given in terms of the ratio of total power in the observed sidebands to the carrier power. This ratio goes up as the square of the multiplication factor and may be written as follows:

$$\frac{P_N}{P_S} = n^2 \frac{P_{oN}}{P_{oS}}$$

where P_N = total sideband power in the multiplied frequency

P_S = carrier power

P_{oN} and P_{oS} = initial (before multiplication) sideband and signal powers

The above formula is only valid if P_N/P_S is very much smaller than unity.

As a numerical example, consider an oscillator at 1 mc with noise phase modulation covering a rectangular band of 10 kc. The sidebands will occupy a 20 kc band centered about the oscillator frequency. Assume that the total sideband power is down 80 db from the oscillator signal so that $P_{oN}/P_{oS} = 10^{-8}$.

By the time the signal is multiplied to 1 gc, $P_N/P_S = 10^{-2}$, which is already a poor spectrum. Frequency multiplication to a higher frequency will result in a very rapid increase of P_N/P_S and spreading of the spectrum.

* Material derived from a paper by Len Cutler entitled, "A Frequency Standard of Exceptional Spectral Purity and Long-Term Stability" delivered before the IRE in March, 1961.

A simple way to improve this situation is to put the oscillator signal through a narrow bandpass filter before multiplication. Assume the filter is centered at 1 mc and has a rectangular passband 20 cycles wide. Total sideband power in the output of the filter will now be 10^3 times smaller, so that $P_{ON}/P_{OS} = 10^{-11}$ and multiplication to 1 gc will give $P_N/P_S = 10^{-5}$, which is still a fairly good spectrum. Therefore, in order to have a narrow spectrum with good signal-to-noise ratio after high-order frequency multiplication the initial signal-to-noise ratio must be very good and/or a narrow band filter must be used between the oscillator and the frequency multiplier.

Even though an oscillator may produce an output which has a very small noise sideband width, the bandwidths and noise levels of the amplifiers necessary for frequency multiplication add a noise contribution to the signal which is significant. This additive noise can be broken into two components, one an effective phase modulation of the signal and the other an effective amplitude modulation. The phase modulation can be treated as previously discussed and leads to the same degradation of the multiplied frequency spectrum. The effective amplitude modulation causes additional phase modulation, indistinguishable from true phase modulation. An oscillator which operates at a low power level in order to achieve good long-term stability will require a great amount of amplification in the multiplication process. It is apparent, therefore, that such oscillators will not in general, have good power spectra after being amplified and then multiplied to the microwave region, unless the frequency multiplier is preceded by a very narrow band filter.

It should be mentioned that coherent signal phase modulation, such as that due to the primary power

supply, is handled in exactly the same manner as noise phase modulation described above, except that there are a discrete number of sidebands present instead of a continuous distribution. The sideband power-to-carrier power ratio can still be stated as in the formula given above.

5-4. DESIGN OF hp QUARTZ OSCILLATOR.

The hp Models 103AR and 104AR Quartz Oscillators are designed to achieve good long- and short-term stability over a wide range of ambient environmental conditions. In addition, the Model 104AR is designed to produce a 5 mc signal of extreme spectral purity as shown in figure 5-1.

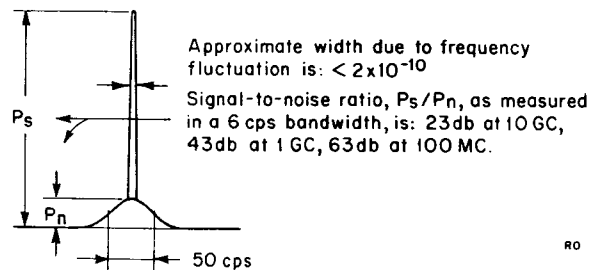

Figure 5-1. Typical Spectral Purity, hp Model 104AR

Circuitry and components are identical in the Models 103AR and 104AR (see figure 5-2), with the exception of additional circuitry associated with the 5 mc output in the Model 104AR.

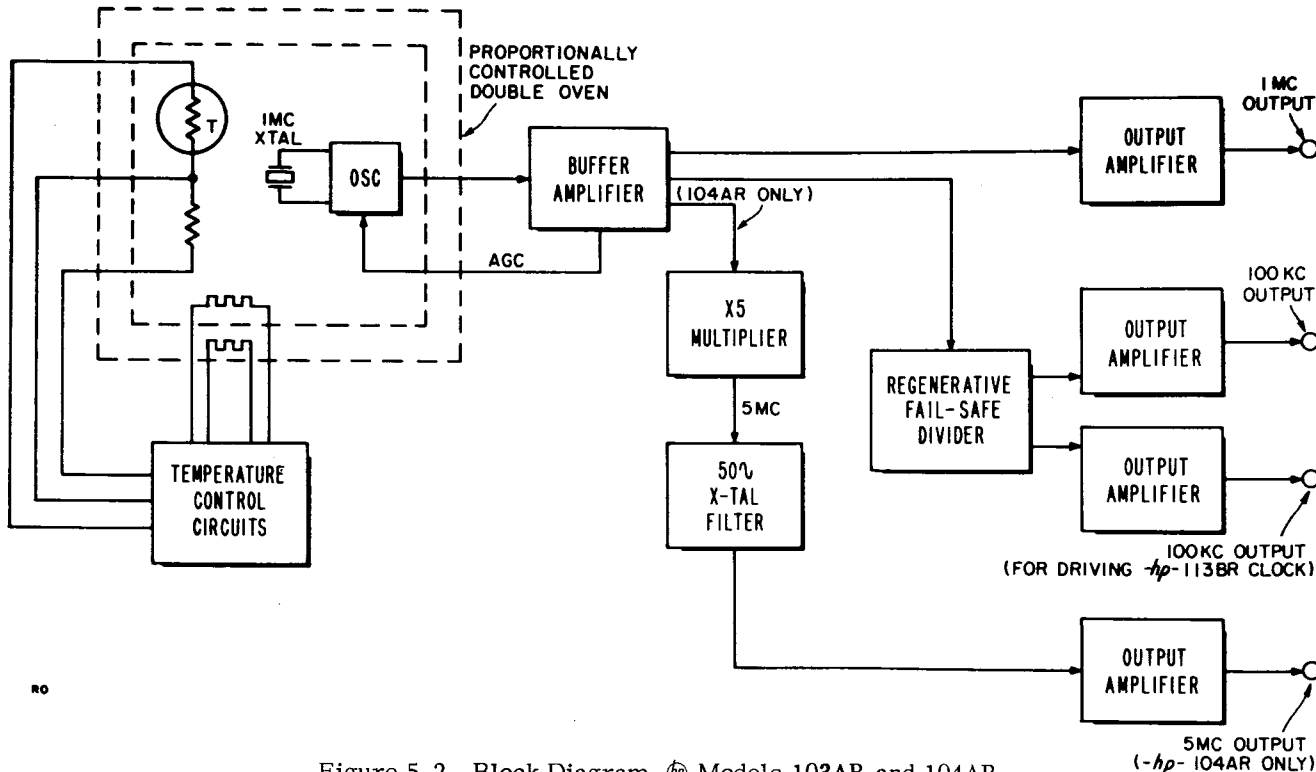

Figure 5-2. Block Diagram, hp Models 103AR and 104AR

The oscillator crystal is an AT cut with zero temperature coefficient at about 65°C. The Q is approximately 2×10^6 and the power dissipated in the crystal is about 0.2 microwatt. The proportionally-controlled double oven, housing the crystal, oscillator transistor and reactance elements maintains temperature within 0.01°C over an ambient temperature range of 0° to 50°C. The Models 103AR and 104AR are completely transistorized for low power consumption and reliability.

The modified Pierce-type oscillator feeds an agc amplifier and rectifier. Those circuits serve to maintain the low oscillator operating level at a constant value and also act as a buffer amplifier. Following is a 1 mc buffer amplifier which provides a

1 mc sine-wave output. 1 mc is also taken from the agc amplifier and divided to 100 kc by a fail-safe regenerative divider. Two 100-kc sine-wave outputs are then provided through separate buffer amplifiers, so that heavy loading of an output will not affect the other outputs. In the Model 104AR, 1 mc is taken from the agc amplifier, multiplied to 5 mc, and filtered with a crystal filter having a bandwidth of 50 cycles per second. This spectrally-pure signal is provided through a buffer amplifier to an output connector.

Figure 5-3 gives an indication of the stability performance that may be expected of a typical Model 103AR or 104AR, with frequency multiplication into the microwave region.

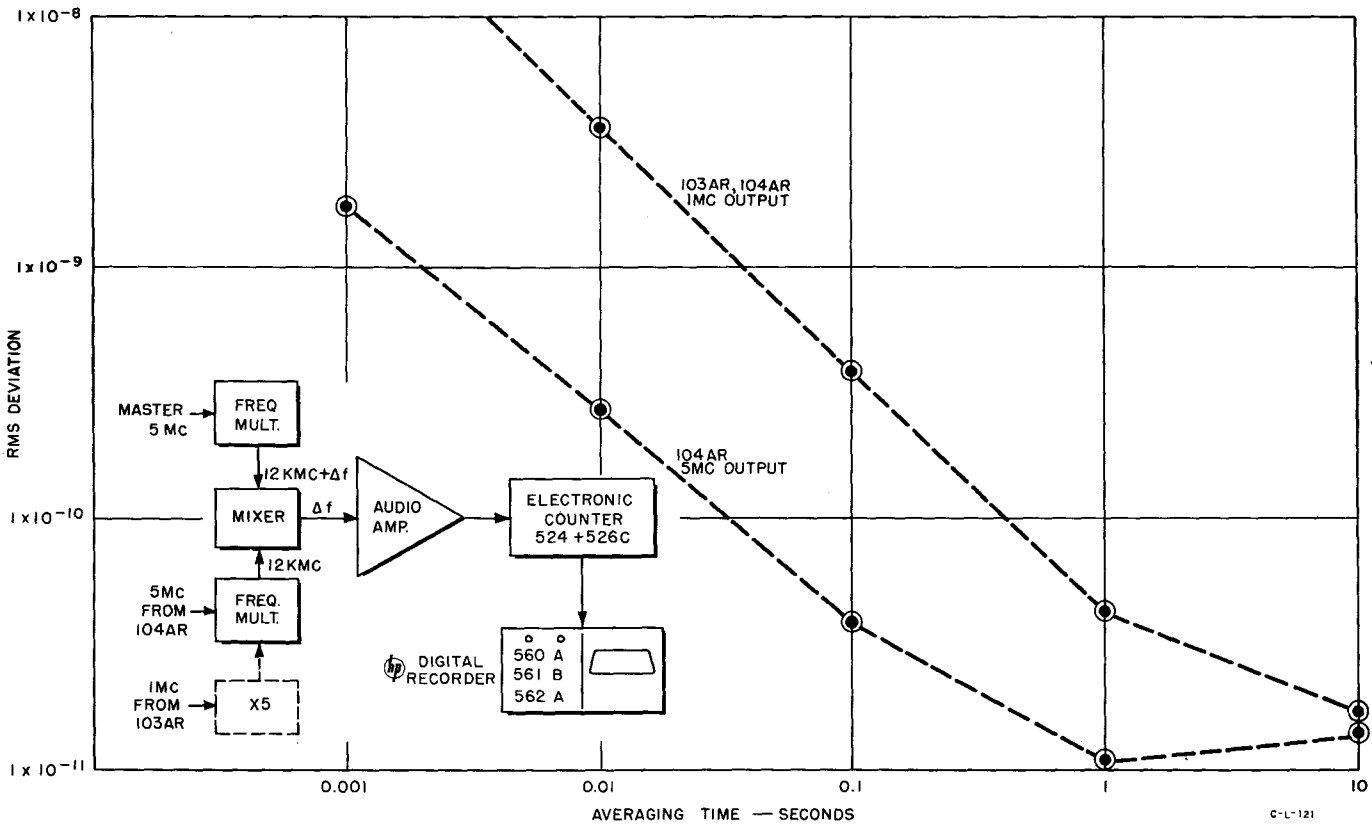

Figure 5-3. Representative Stability Curves with Block Diagram Setup for Model 103AR and 104AR Oscillators

APPENDIX I TIME

1. INTRODUCTION.

Through the years much effort has been devoted toward finding a measurement reference form which a uniform time scale could be established. Until very recently, the reference used was the rotation of the earth about its axis with respect to the sun. A unit of time derived from observations of the apparent movement of the sun will obviously be a constant value only if the sun reappears over a fixed point of observation at uniform intervals. As man has increased the precision with which astronomical observations can be made it has been found that the rotation of the earth does not represent a uniform time scale. Even after all possible corrections are made for the known regular variations in the measurement conditions there still remains secular and irregular variations in the rotational speed of the earth which cause corresponding changes in this type of time scale. For this reason the unit of time now adopted as fundamental is based on the orbital motion of the earth rather than its rotation and is therefore tied to gravitational phenomena. This appears to give a uniform reference. The purpose of this appendix is to discuss in some detail our national standards of time in the context of their historical development. The means by which these standards are made available to interested users is also presented.

2. APPARENT SOLAR TIME.

An apparent solar day is dependent upon the position of the sun. Measurements made with a sun dial, for example, would give apparent time, since it would be in terms of the actual relative position of the sun. If the earth's orbit were a perfect circle and lay in the plane of the equator, the length of an apparent day would remain constant throughout the year.

Of course, the earth's orbit is not circular, it is elliptical, and the orbital plane does not coincide

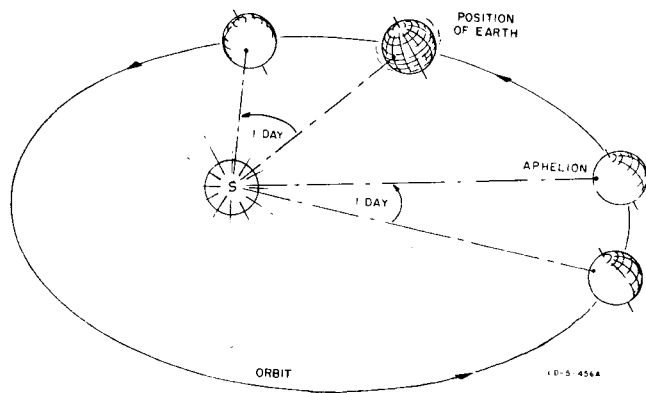

Figure 1. Exaggerated presentation of earth's orbital motion shows varying effect on apparent solar day. Point on earth represents a given meridian.

with the plane of the equator; it is at an angle of 23.5° to it. Because of this, apparent days vary in length. (The orbital speed of an object whose path describes an elliptic is constantly changing. The earth, as viewed from the sun, moves faster along that part of the orbit nearest the sun than at other times. Figure 1 shows how this affects solar measurements.) The amount by which the length of apparent days differ from the mean is called the equation of time. It has its maximum value early in November when the difference is about 16 minutes.

3. MEAN SOLAR TIME.

Mean solar time is simply apparent time averaged to eliminate variations due to orbital eccentricity and the tilt of the earth's axis. A mean solar day is the average of all the apparent days in the year and a mean solar second is equal to a mean solar day divided by 86,400. As a fundamental unit of time the mean solar second is inadequate because it is still tied to the rotation of the earth which is now known to be non-uniform.

4. UNIVERSAL TIME.

As with mean solar time, Universal Time (UT) is based on the rotation of the earth about its axis; the units UT were chosen so that on the average, local noon would occur when the sun was on the local meridian. UT, thus defined, made the assumption that the rotation of the earth was constant and that it would, therefore, be a uniform time scale. It is now known that the rotation of the earth is subject to periodic, secular, and irregular variations, and universal time is naturally subject to these same variations. When uncorrected, the units of universal time are equivalent to the mean solar second, and are identified as a time scale by the designation UT0.

Correction to UT0 has led to two subsequent universal time scales: UT1 and UT2. UT1 recognizes that the earth is subject to polar motion. The effect of this polar motion is to give an error to any uncorrected measurement of the earth's angular rotation. Figure 2 illustrates this. UT1, then, is a time scale based on the true angular rotation of the earth about its axis.

The UT2 time scale is UT1 with an additional correction for seasonal variations in the rotation of the earth: These variations are apparently caused by seasonal displacement of matter over the earth's surface, such as changes in the amount of ice in the polar regions as the sun moves from southern hemisphere to northern and back again through the year. This cyclic redistribution of mass acts on the earth's rotation since it amounts to seasonal changes in its movement of inertia.

The time scale in widest use today is UT2. It represents the mean angular motion of the earth, freed of periodic variations, but still affected by irregular variation and secular variation. The units now provided by standard broadcast stations (WWV, WWVH, NBA and others) are in substantial agreement with the current value of the unit of UT2.

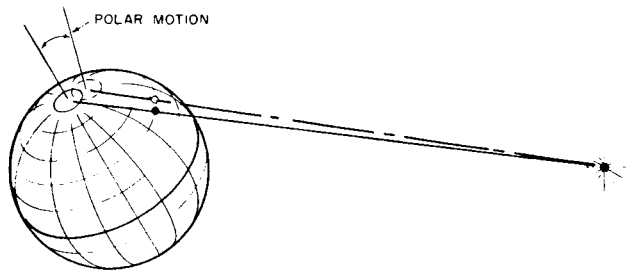

Figure 2. Polar motion changes the apparent position of a fixed point of observation with respect to a distant celestial body. Thus, the amount of angular rotation required to bring a star directly over the local meridian will not be constant. UT1 time is corrected for polar motion.

5. EPHEMERIS TIME.

As discussed, the rotation of the earth on its axis does not take place at a constant rate and, as a result, time units derived from it do not provide an invariable standard. Even when all possible corrections have been made, an insurmountable uncertainty still remains since the rate of rotation of the earth fluctuates unpredictably. (These irregular changes are thought to be due to readjustments in the interior of the globe that produce small changes in diameter.) Furthermore, the earth is known to be slowing in its angular rate in a secular manner due to tidal friction. This change amounts to about a millisecond per century and, since it is secular, does not lend itself to correction in uniform time units.

The search for a uniform time unit has led astronomers to define an additional kind of time called Ephemeris Time (ET). Ephemeris time is astronomical time based on the motion of the earth about the sun. It is obtained in practice from observations of the motion of the moon about the earth. In October, 1956, the International Committee of Weights and Measures defined the second of ET as the fraction $1/31,556,925.9747$ of the tropical year for January 0, 1900 at 12 hours ephemeris time. The tropical year for the moment of 12 hours, January 0, 1900, is the length the tropical year would be if the sun continued at its apparent instantaneous rate, corrected for orbital eccentricity and nutation of the earth's axis.

The second of ET, thus defined, appears to fulfill the requirements for an invariable unit of time and has replaced the second of UT as the fundamental unit. (Universal time is the time by which we live, however, and the broadcast frequencies of standard stations are set so as to establish a unit in substantial agreement with the current value of UT2. This is covered in more detail in the paragraphs on standard frequency broadcasts, appendix II).

Tables published by Simon Newcomb at the end of the 19th century gave the position of the sun for regular intervals. These intervals, until recently, were thought to be in terms of UT. It is now recognized that ET is the actual scale and the tables may therefore be used as the basis for measuring ET. In other words, the ephemeris time scale places celestial bodies in repeatable astronomical relationships to each other year after year. That this is not true for universal time can be seen from the fact that time kept in UT2 units since 1900 would now be slow by approximately 30 seconds with respect to the uniform ET scale.

As mentioned, ET is obtained in practice by observing the motion of the moon about the earth. Lunar position tables have been constructed in conformity with the internationally adopted solar ephemeris and permit the determination of ET directly from the observation of the moon.

Because of the difficulty of making precise measurements of the position of the moon, except by observations made for a fairly long time, the delay in the determination of ET to any useful degree of accuracy is on the order of several years.

6. ATOMIC TIME.

Atomic time is the uniform time of physics, based on transitions of quantum mechanics. Atomic time appears to be independent of external variable influences and in close agreement with ET, although it is not yet certain that ET and AT are equivalent. Measurements with a cesium-beam resonator have established the relationship between its transition frequency and the second of ET to a fair degree of accuracy. The best value presently available is $9,192,631,770 \pm 20$ cycles per second of ET. To the extent that this indicated relationship holds invariant, atomic time double-checked over the years against ET, can be used to maintain national standards. The advantage is that it is much more readily observable than ET. Cesium-beam standards at the Naval Research Laboratory and at the National Physical Laboratory are being used in a cooperative program with the U.S. naval Observatory for the accurate determination of Ephemeris time.

For the present, the assumption is made that exactly $9,192,631,770$ cycles of a cesium-beam standard is equal to the ephemeris second. The atomic time scale thus defined is identified as A.1.

7. SIDEREAL TIME SCALE.

For some applications it is desirable to have a time scale that takes as its reference the relative position of the stars with respect to the rotation of the earth. Time defined in this manner is called sidereal time.

A sidereal day is strictly defined as the interval between two successive transits of the first point of Aries (a northern constellation) over the upper meridian of any place. In other words, it is the period of rotation of the earth obtained by observation of the stars

and with reference to the stars. By way of comparison, a mean solar day is also obtained in practice from observations of the stars, but the measurement of rotation is referenced to the sun.

A sidereal day contains 24 sidereal hours, each having 60 sidereal minutes of 60 sidereal seconds. In mean solar time a sidereal day is about 23 hours, 56 minutes, and 4.09 seconds. The time difference in the two days is due to the earth's motion about the sun and the influence of this motion on the apparent position of the sun among the stars. What happens is that during the course of day, orbital motion causes the sun to appear to move a little to the east among the stars. Even if the earth did not rotate, the sun would appear to move eastward completely around the earth during one period of the earth's orbit. The effect of this apparent motion is that the day referenced to the sun is about 4 minutes longer than the day referenced to the stars (see figure 3). For the same reason, a solar year will contain 366.24+ sidereal days, or one more than the number of mean solar days.

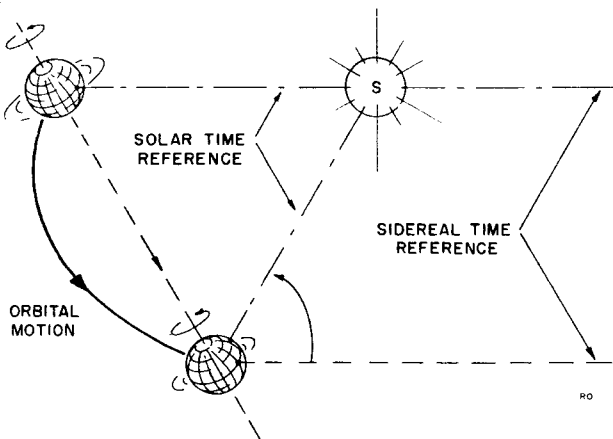

Figure 3. Length of solar day is referenced to the sun. The effect of orbital motion, therefore, is to lengthen the solar day over what it would be if the earth were fixed in position. Since sidereal time is referenced to distant stars, orbital motion is of no consequence and the length of the sidereal day is not influenced by the motion of the earth about the sun. The cumulative effect of this is that in a year's time the earth when referenced to the sun appears to make one less revolution than when referenced to a distant star.

A clock keeping time in sidereal units must, in the course of a tropical year, indicate the passage of one day more than it would indicate in mean solar

units.* Or, in another way, the ratio of its units compared to the units of mean solar time must be as 366.24 is to 365.24. This is why an \odot Model 113B Clock will indicate sidereal time when driven from a stable frequency source of 100.27379 kc and solar time when the source is 100 kc.

8. DEFINING THE SOLAR AND SIDEREAL YEAR FROM ASTRONOMICAL RELATIONSHIPS.

The solar (or tropical) year is a measure of the period of the earth's orbit as defined by observation of the time from vernal equinox to vernal equinox. Vernal equinox occurs about March 21 and is the time when the sun moves from the southern to the northern hemisphere in its apparent motion along the ecliptic: The ecliptic is the great circle formed by the intersection of the earth's orbital plane with the earth. It is along this great circle-intersecting the equator at about 23.5° that the sun appears to move in a direction opposite to the earth's actual motion about the sun. One period of the ecliptic, then, is one solar year. See figure 4. A solar year is presently equal, in mean solar time, to 365 days, 5 hours, 48 minutes and 45.5 seconds, or in decimal form 365.24219879 mean solar days.

Because the solar year by which we reckon time is 365 days plus a fraction, corrections must be made to our calendar at various times in order to make it correspond with the sun.

A sidereal year is a measure of the exact period of revolution of the earth around the sun. It is the true time interval required for the earth to move from a position of alignment with a given star as seen from the sun to the same position of alignment again. This is illustrated in figure 5.

A sidereal year contains 365.25636042 mean solar days. Compared to the solar, or tropical, year of 365.24219879 mean solar days, the sidereal year is the longer by about 20 minutes. The reason for this is that the solar year is based not on the period of the earth with respect to a fixed point on the orbit, but on the vernal equinox. Since the equinoxes are subject to precession, the point at which the sun appears to move from the southern to the northern hemisphere does not occur at precisely the same point on the orbital path from year to year. Therefore it follows that the solar year will differ from the sidereal year. Since the precession is westward, equinox occurs sooner than it would if there were no motion of precession. This causes the solar year to be shorter than the sidereal year by about 20 minutes.

* Mean sidereal time differs from apparent sidereal time because of the nodding or nutation of the earth's axis. This difference has a maximum value of only about a second and changes on a daily basis amount to a hundredth of a second or so. Sidereal time is not influenced, however, by the orbital motion of the earth, since the stars that are observed are so distant that their apparent positions do not vary as the earth moves about the sun. Because the differences between mean and apparent sidereal time are so small, sidereal time is the scale generally used by astronomers.

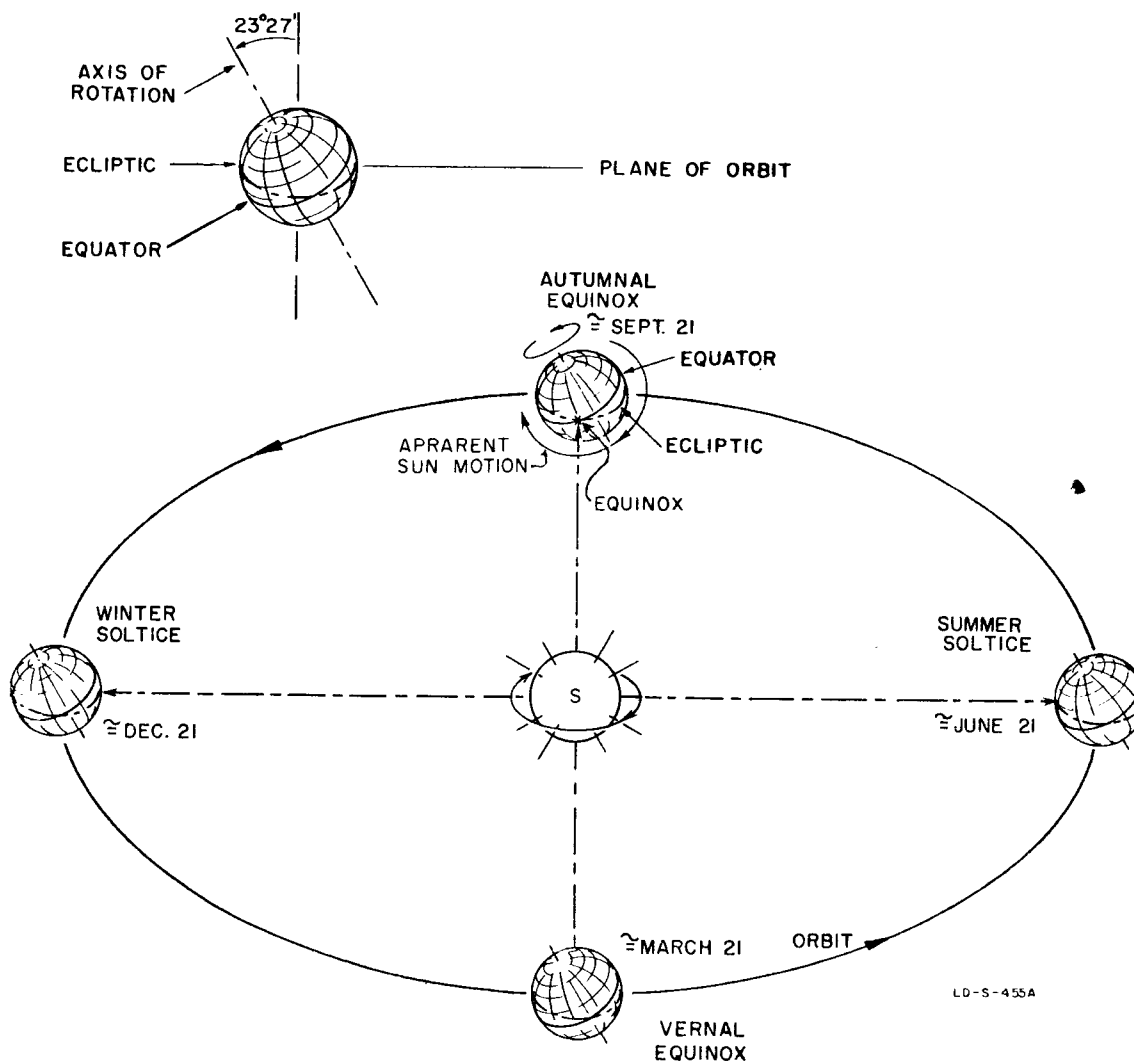

Figure 4. Illustration shows path of ecliptic traced by position of sun as earth moves about it. Equinoxes are those points where ecliptic intersects the equator.

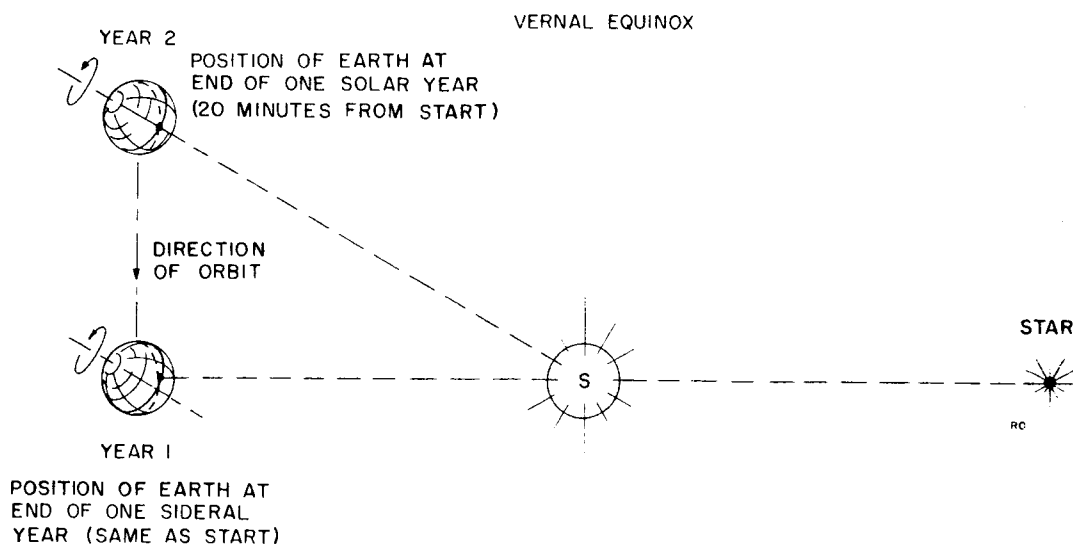

Figure 5. Precession of the equinoxes causes solar year to be about 20 minutes shorter than sidereal year. That is, the westward motion of the equinoctial points makes the measurement of a year based on the vernal equinox shorter than it would be if there were no precession.

APPENDIX II

NATIONAL STANDARDS OF TIME AND FREQUENCY

1. UNITED STATES FREQUENCY STANDARD.

The United States Frequency Standard is maintained at the Boulder Laboratories National Bureau of Standards. It consists of the weighted average of the outputs of several actual oscillators and resonators. In practice, the Bureau uses devices that represent the best available at any current state of the frequency control art. Prior to October 9, 1957, the value of the USFS was maintained as constant as possible with respect to the UT2 second as determined by the U.S. Naval Observatory. It is presently maintained with respect to atomic frequency standards, which are compared with other atomic standards and with astronomical observations.

Since January 1, 1960, the value of the U.S. Frequency Standard has been converted to bring it more closely into agreement with the scale of ET as it is now known. As before, atomic standards provide the actual working reference scale on the basis of certain assumed atomic frequency and ephemeris time relationships. At present 100,000,000 periods of the USFS are held equal to 9,192,631,770 periods of cesium-beam oscillations. The absolute accuracy of the USFS can, therefore, be described as equal to the accuracy with which the frequency of an atomic standard can be stated per second of ET plus the intercomparison accuracy of the several atomic standards used. As stated previously, the best value now available for an atomic standard is the transition frequency of a cesium-beam resonator. The value of 9,192,631,770 \pm 20 cycles oscillations per second of ET amounts to an accuracy of \pm 22 parts in 10^{10} . The continuing program being carried on by the Naval Research Laboratory and the Naval Observatory for checking the cesium-beam standard against astronomical observations should, in the course of several years, result in an improvement in the precision with which the value of atomic oscillations can be stated per unit of ET.

Perhaps, the stability of the United States Frequency Standard is even more important to users of information derived from it than its "absolute" accuracy in terms of the uniform ephemeris time scale. Accepting the present limitations on the USFS accuracy due to the remaining uncertainty in the cesium transition frequency per second of ET, its usefulness as a national reference depends upon the stability with which it can be maintained. At present, the USFS is held constant within less than a part in 10^{10} .

2. STANDARD BROADCASTS.

Standard broadcast stations are in operation throughout the world for the purpose of making available national standards of time and frequency. In the

United States, the Bureau of Standards and the Navy operate standards stations whose frequencies are maintained as constant as possible with respect to the United States Frequency Standard. Unavoidable variations in the broadcast frequencies do occur, and for this reason, monthly tables are published which give the amount of these variations with respect to the USFS. Typical variations are on the order of a few parts in 10^{10} from one day to the next with 1 or 2 parts in 10^{10} being a common figure. The stability and accuracy of standard broadcast frequencies in the U.S. with respect to the USFS are constantly being improved.

Note that stability and accuracy figures given for standard broadcast frequencies are with relation to national standards and can be related to fundamental units (the second of ET) only within the limits of accuracy and stability of the national standards themselves.

3. CARRIER OFFSET.

The various frequencies of all the standard broadcast stations in the U.S. are offset from the United States Frequency Standard. That is, the broadcast frequencies are based on the value of the USFS--or some multiple of sub-multiple of it--minus a fixed amount of offset. To see the reason for this, it must be remembered that the USFS is based on a uniform time scale while the time by which we live is a variable scale. Our lives in general are governed by the rotation of the earth and the various time intervals, such as hours, days, and years, that are defined in terms of that rotation.

Since the USFS is presently maintained by atomic standards in terms of oscillations per second of ET, agreement with other time scales whose units differ from that of the second of ET must be represented by oscillations offset from the USFS by an amount proportional to the difference in the units of time used.

Carrier frequencies of the U.S. Standard stations are now offset by -130 parts in 10^{10} which establishes a unit in substantial agreement with the current value of the unit of UT2. In other words, time signals locked to a frequency offset from the USFS by -130 parts in 10^{10} are in units that agree closely with the UT2 unit. Since UT2 is not an invariable time scale, the relation of its units to the uniform unit of ET will change. Conformity of the standard broadcast frequencies and time signals with the unit of UT2 will be accomplished by changes in the amount of offset. The last change in the amount of offset occurred January 1, 1962: Two years prior to this date offset was -150 parts in 10^{10} .

4. TIME CORRECTIONS.

Even with offset determined very precisely, cumulative time errors (in terms of the UT2 scale) do occur in the time of day information broadcast by some of the standard stations. These errors are corrected by step adjustments in the time signals to bring them into closer correspondence with actual UT2 time.

The adjustments, if required, will ordinarily be made on January 1st of each year. However, a step adjustment will be made at announced dates whenever the broadcast time discrepancy exceeds ± 30 ms. These adjustments do not influence the units of UT2, however, which are established by the value of the broadcast frequency and its offset from the United States Frequency Standard.

APPENDIX III TABLES

TABLE 1. EQUIVALENTS

1 day = 8.64×10^7 milliseconds
= 8.64×10^{10} microseconds

1' of arc on surface of earth = 1 nautical mile
= 1.151 statute miles
= 1.853 kilometers

1° of arc on surface of earth = 60 nautical miles
= 111.195 kilometers

1 kilometer = 0.6214 statute miles

TABLE 2. LOGARITHMS OF COSINE FUNCTION
(0° to 45°)

Note: Append -10 to each logarithm

0	0'	10'	20'	30'	40'	50'	60'
0	0.0000	0.0000	0.0000	0.0000	0.0000	9.9999	9.9999
1	9.9999	9.9999	9.9999	9.9999	9.9998	9.9998	9.9997
2	9.9997	9.9997	9.9996	9.9996	9.9995	9.9995	9.9994
3	9.9994	9.9993	9.9993	9.9992	9.9991	9.9990	9.9989
4	9.9989	9.9989	9.9988	9.9987	9.9986	9.9985	9.9983
5	9.9983	9.9982	9.9981	9.9980	9.9979	9.9977	9.9976
6	9.9976	9.9975	9.9973	9.9972	9.9971	9.9969	9.9968
7	9.9968	9.9966	9.9964	9.9963	9.9961	9.9959	9.9958
8	9.9958	9.9956	9.9954	9.9952	9.9950	9.9948	9.9946
9	9.9946	9.9944	9.9942	9.9940	9.9938	9.9936	9.9934
10	9.9934	9.9931	9.9929	9.9927	9.9924	9.9922	9.9919
11	9.9919	9.9917	9.9914	9.9912	9.9909	9.9907	9.9904
12	9.9904	9.9901	9.9899	9.9896	9.9893	9.9890	9.9887
13	9.9887	9.9884	9.9881	9.9878	9.9875	9.9872	9.9869
14	9.9869	9.9866	9.9863	9.9859	9.9856	9.9853	9.9849
15	9.9849	9.9846	9.9843	9.9839	9.9836	9.9832	9.9828
16	9.9828	9.9825	9.9821	9.9817	9.9814	9.9810	9.9806
17	9.9806	9.9802	9.9798	9.9794	9.9790	9.9786	9.9782
18	9.9782	9.9778	9.9774	9.9770	9.9765	9.9761	9.9757
19	9.9757	9.9752	9.9748	9.9743	9.9739	9.9734	9.9730
20	9.9730	9.9725	9.9721	9.9716	9.9711	9.9706	9.9702
21	9.9702	9.9697	9.9692	9.9687	9.9682	9.9677	9.9672
22	9.9672	9.9667	9.9661	9.9656	9.9651	9.9646	9.9640
23	9.9640	9.9635	9.9629	9.9624	9.9618	9.9613	9.9607
24	9.9607	9.9602	9.9596	9.9590	9.9584	9.9579	9.9573
25	9.9573	9.9567	9.9561	9.9555	9.9549	9.9543	9.9537
26	9.9537	9.9530	9.9524	9.9518	9.9512	9.9505	9.9499
27	9.9499	9.9492	9.9486	9.9479	9.9473	9.9466	9.9459
28	9.9459	9.9453	9.9446	9.9439	9.9432	9.9425	9.9418
29	9.9418	9.9411	9.9404	9.9397	9.9390	9.9383	9.9375
30	9.9375	9.9368	9.9361	9.9353	9.9346	9.9338	9.9331
31	9.9331	9.9323	9.9315	9.9308	9.9300	9.9292	9.9284
32	9.9284	9.9276	9.9268	9.9260	9.9252	9.9244	9.9236
33	9.9236	9.9228	9.9219	9.9211	9.9203	9.9194	9.9186
34	9.9186	9.9177	9.9169	9.9160	9.9151	9.9142	9.9134
35	9.9134	9.9125	9.9116	9.9107	9.9098	9.9089	9.9080
36	9.9080	9.9070	9.9061	9.9052	9.9042	9.9033	9.9023
37	9.9023	9.9014	9.9004	9.8995	9.8985	9.8975	9.8965
38	9.8965	9.8955	9.8945	9.8935	9.8925	9.8915	9.8905
39	9.8905	9.8895	9.8884	9.8874	9.8864	9.8853	9.8843
40	9.8843	9.8832	9.8821	9.8810	9.8800	9.8789	9.8778
41	9.8778	9.8767	9.8756	9.8745	9.8733	9.8722	9.8711
42	9.8711	9.8699	9.8688	9.8676	9.8665	9.8653	9.8641
43	9.8641	9.8629	9.8618	9.8606	9.8594	9.8582	9.8569
44	9.8569	9.8557	9.8545	9.8532	9.8520	9.8507	9.8495

TABLE 2. LOGARITHMS OF COSINE FUNCTION (Cont'd)
(45° to 90°)

Note: Append -10 to each logarithm

0	0'	10'	20'	30'	40'	50'	60'
45	9.8495	9.8482	9.8469	9.8457	9.8444	9.8431	9.8418
46	9.8418	9.8405	9.8391	9.8378	9.8365	9.8351	9.8338
47	9.8338	9.8324	9.8311	9.8297	9.8283	9.8269	9.8255
48	9.8255	9.8241	9.8227	9.8213	9.8198	9.8184	9.8169
49	9.8169	9.8155	9.8140	9.8125	9.8111	9.8096	9.8081
50	9.8081	9.8066	9.8050	9.8053	9.8020	9.8004	9.7989
51	9.7989	9.7973	9.7957	9.7941	9.7926	9.7910	9.7893
52	9.7893	9.7877	9.7861	9.7844	9.7828	9.7811	9.7795
53	9.7795	9.7778	9.7761	9.7744	9.7727	9.7710	9.7692
54	9.7692	9.7675	9.7657	9.7640	9.7622	9.7604	9.7586
55	9.7586	9.7568	9.7550	9.7531	9.7513	9.7494	9.7476
56	9.7476	9.7457	9.7438	9.7419	9.7400	9.7380	9.7361
57	9.7361	9.7342	9.7322	9.7302	9.7282	9.7262	9.7242
58	9.7242	9.7222	9.7201	9.7181	9.7160	9.7139	9.7118
59	9.7118	9.7097	9.7076	9.7055	9.7033	9.7012	9.6990
60	9.6990	9.6968	9.6946	9.6923	9.6901	9.6878	9.6856
61	9.6856	9.6833	9.6810	9.6787	9.6763	9.6740	9.6716
62	9.6716	9.6692	9.6668	9.6644	9.6620	9.6595	9.6570
63	9.6570	9.6546	9.6521	9.6495	9.6470	0.6442	9.6418
64	9.6418	9.6392	9.6366	9.6340	9.6313	9.6286	9.6259
65	9.6259	9.6232	9.6205	9.6177	9.6149	9.6121	9.6093
66	9.6093	9.6065	9.6036	9.6007	9.5978	9.5948	9.5919
67	9.5919	9.5889	9.5859	9.5828	9.5798	9.5767	9.5736
68	9.5736	9.5704	9.5673	9.5641	9.5609	9.5576	9.5543
69	9.5543	9.5510	9.5477	9.5443	9.5409	9.5375	9.5341
70	9.5341	9.5306	9.5270	9.5235	9.5199	9.5163	9.5126
71	9.5126	9.5090	9.5052	9.5015	9.4977	9.4939	9.4900
72	9.4900	9.4861	9.4821	9.4781	9.4741	9.4700	9.4659
73	9.4659	9.4618	9.4576	9.4533	9.4491	9.4447	9.4403
74	9.4403	9.4359	9.4314	9.4269	9.4223	9.4177	9.4130
75	9.4130	9.4083	9.4035	9.3986	9.3937	9.3887	9.3837
76	9.3837	9.3786	9.3734	9.3682	9.3629	9.3575	9.3521
77	9.3521	9.3466	9.3410	9.3353	9.3296	9.3238	9.3179
78	9.3179	9.3119	9.3058	9.2997	9.2934	9.2870	9.2806
79	9.2806	9.2740	9.2674	9.2606	9.2538	9.2468	9.2397
80	9.2397	9.2324	9.2251	9.2176	9.2100	9.2022	9.1943
81	9.1943	9.1863	9.1781	9.1697	9.1612	9.1525	9.1436
82	9.1436	9.1345	9.1252	9.1157	9.1060	9.0961	9.0859
83	9.0859	9.0755	9.0648	9.0539	9.0426	9.0311	9.0192
84	9.0192	9.0070	8.9945	8.9816	8.9682	8.9545	8.9403
85	8.9403	8.9256	8.9104	8.8946	8.8783	8.8613	8.8436
86	8.8436	8.8251	8.8059	8.7857	8.7645	8.7423	8.7188
87	8.7188	8.6940	8.6677	8.6397	8.6097	8.5776	8.5428
88	8.5428	8.5050	8.4637	8.4179	8.3668	8.3088	8.2419
89	8.2419	8.1627	8.0658	7.9408	7.7648	7.4637	--

TABLE 3. HAVERSINES
(0° to 44°)

Note: Characteristics of the logarithms are omitted.

°	0'		10'		20'		30'		40'		50'	
	Nat	Log	Nat	Log	Nat	Log	Nat	Log	Nat	Log	Nat	Log
0	.0000	—	.0000	6̄ .3254	.0000	6̄ .9275	.0000	5̄ .2796	.0000	5̄ .5295	.0001	5̄ .7233
1	.0001	5̄ .8817	.0001	.0156	.0001	.1316	.0002	.2339	.0002	.3254	.0003	.4081
2	.0003	.4837	.0004	.5532	.0004	.6176	.0005	.6775	.0005	.7336	.0006	.7862
3	.0007	.8358	.0008	.8828	.0008	.9273	.0009	.9697	.0010	.0101	.0011	.0487
4	.0012	.0856	.0013	.1211	.0014	.1551	.0015	.1879	.0017	.2195	.0018	.2499
5	.0019	.2794	.0020	.3078	.0022	.3354	.0023	.3621	.0024	.3880	.0026	.4132
6	.0027	.4376	.0029	.4614	.0031	.4845	.0032	.5071	.0034	.5290	.0036	.5504
7	.0037	.5714	.0039	.5918	.0041	.6117	.0043	.6312	.0045	.6503	.0047	.6689
8	.0049	.6872	.0051	.7051	.0053	.7226	.0055	.7397	.0057	.7566	.0059	.7731
9	.0062	.7893	.0064	.8052	.0066	.8208	.0069	.8361	.0071	.8512	.0073	.8660
10	.0076	.8806	.0079	.8949	.0081	.9090	.0084	.9229	.0086	.9365	.0089	.9499
11	.0092	.9631	.0095	.9762	.0097	.9890	.0100	.0016	.0103	.0141	.0106	.0264
12	.0109	.0385	.0112	.0504	.0115	.0622	.0119	.0738	.0122	.0852	.0125	.0966
13	.0128	.1077	.0131	.1187	.0135	.1296	.0138	.1404	.0142	.1510	.0145	.1614
14	.0149	.1718	.0152	.1820	.0156	.1921	.0159	.2021	.0163	.2120	.0167	.2217
15	.0170	.2314	.0174	.2409	.0178	.2504	.0182	.2597	.0186	.2689	.0190	.2781
16	.0194	.2871	.0198	.2961	.0202	.3049	.0206	.3137	.0210	.3223	.0214	.3309
17	.0218	.3394	.0223	.3478	.0227	.3561	.0231	.3644	.0236	.3726	.0240	.3807
18	.0245	.3887	.0249	.3966	.0254	.4045	.0258	.4123	.0263	.4200	.0268	.4276
19	.0272	.4352	.0277	.4427	.0282	.4502	.0287	.4576	.0292	.4649	.0297	.4721
20	.0302	.4793	.0307	.4865	.0312	.4935	.0317	.5006	.0322	.5075	.0327	.5144
21	.0332	.5213	.0337	.5281	.0343	.5348	.0348	.5415	.0353	.5481	.0359	.5547
22	.0364	.5612	.0370	.5677	.0375	.5741	.0381	.5805	.0386	.5868	.0392	.5931
23	.0397	.5993	.0403	.6055	.0409	.6116	.0415	.6177	.0421	.6238	.0426	.6298
24	.0432	.6358	.0438	.6417	.0444	.6476	.0450	.6534	.0456	.6592	.0462	.6650
25	.0468	.6707	.0475	.6764	.0481	.6820	.0487	.6876	.0493	.6932	.0500	.6987
26	.0506	.7042	.0512	.7096	.0519	.7150	.0525	.7204	.0532	.7258	.0538	.7311
27	.0545	.7364	.0552	.7416	.0558	.7468	.0565	.7520	.0572	.7572	.0578	.7623
28	.0585	.7674	.0592	.7724	.0599	.7774	.0606	.7824	.0613	.7874	.0620	.7923
29	.0627	.7972	.0634	.8021	.0641	.8069	.0648	.8117	.0655	.8165	.0663	.8213
30	.0670	.8260	.0677	.8307	.0684	.8354	.0692	.8400	.0699	.8446	.0707	.8492
31	.0714	.8538	.0722	.8583	.0729	.8629	.0737	.8673	.0744	.8718	.0752	.8763
32	.0760	.8807	.0767	.8851	.0775	.8894	.0783	.8938	.0791	.8981	.0799	.9024
33	.0807	.9067	.0815	.9109	.0823	.9152	.0831	.9194	.0839	.9236	.0847	.9277
34	.0855	.9319	.0863	.9360	.0871	.9401	.0879	.9442	.0888	.9482	.0896	.9523
35	.0904	.9563	.0913	.9603	.0921	.9643	.0929	.9682	.0938	.9721	.0946	.9761
36	.0955	.9800	.0963	.9838	.0972	.9877	.0981	.9915	.0989	.9954	.0998	.9992
37	.1007	.0030	.1016	.0067	.1024	.0105	.1033	.0142	.1042	.0179	.1051	.0216
38	.1060	.0253	.1069	.0289	.1078	.0326	.1087	.0362	.1096	.0398	.1105	.0434
39	.1114	.0470	.1123	.0505	.1133	.0541	.1142	.0576	.1151	.0611	.1160	.0646
40	.1170	.0681	.1179	.0716	.1189	.0750	.1198	.0784	.1207	.0819	.1217	.0853
41	.1226	.0887	.1236	.0920	.1246	.0954	.1255	.0987	.1265	.1020	.1275	.1054
42	.1284	.1087	.1294	.1119	.1304	.1152	.1314	.1185	.1323	.1217	.1333	.1249
43	.1343	.1282	.1353	.1314	.1363	.1345	.1373	.1377	.1383	.1409	.1393	.1440
44	.1403	.1472	.1413	.1503	.1424	.1534	.1434	.1565	.1444	.1596	.1454	.1626

TABLE 3. HAVERSINES (Cont'd)
(45° to 89°)

Note: Characteristics of the logarithms are omitted.

°	0'		10'		20'		30'		40'		50'	
	Nat	Log	Nat	Log	Nat	Log	Nat	Log	Nat	Log	Nat	Log
45	.1464	.1657	.1475	.1687	.1485	.1718	.1495	.1748	.1506	.1778	.1516	.1808
46	.1527	.1838	.1537	.1867	.1548	.1897	.1558	.1926	.1569	.1956	.1579	.1985
47	.1590	.2014	.1601	.2043	.1611	.2072	.1622	.2101	.1633	.2129	.1644	.2158
48	.1654	.2186	.1665	.2215	.1676	.2243	.1687	.2271	.1698	.2299	.1709	.2327
49	.1720	.2355	.1731	.2382	.1742	.2410	.1753	.2437	.1764	.2465	.1775	.2492
50	.1786	.2519	.1797	.2546	.1808	.2573	.1820	.2600	.1831	.2627	.1842	.2653
51	.1853	.2680	.1865	.2706	.1876	.2732	.1887	.2759	.1899	.2785	.1910	.2811
52	.1922	.2837	.1933	.2863	.1945	.2888	.1956	.2914	.1968	.2940	.1979	.2965
53	.1991	.2991	.2003	.3016	.2014	.3041	.2026	.3066	.2038	.3091	.2049	.3116
54	.2061	.3141	.2073	.3166	.2085	.3190	.2096	.3215	.2108	.3239	.2120	.3264
55	.2132	.3288	.2144	.3312	.2156	.3336	.2168	.3361	.2180	.3384	.2192	.3408
56	.2204	.3432	.2216	.3456	.2228	.3480	.2240	.3503	.2252	.3527	.2265	.3550
57	.2277	.3573	.2289	.3596	.2301	.3620	.2314	.3643	.2326	.3666	.2338	.3689
58	.2350	.3711	.2363	.3734	.2375	.3757	.2388	.3779	.2400	.3802	.2412	.3824
59	.2425	.3847	.2437	.3869	.2450	.3891	.2462	.3913	.2475	.3935	.2487	.3957
60	.2500	.3979	.2513	.4001	.2525	.4023	.2538	.4045	.2551	.4066	.2563	.4088
61	.2576	.4109	.2589	.4131	.2601	.4152	.2614	.4173	.2627	.4195	.2640	.4216
62	.2653	.4237	.2665	.4258	.2678	.4279	.2691	.4300	.2704	.4320	.2717	.4341
63	.2730	.4362	.2743	.4382	.2756	.4403	.2769	.4423	.2782	.4444	.2795	.4464
64	.2808	.4484	.2821	.4504	.2834	.4524	.2847	.4545	.2861	.4565	.2874	.4584
65	.2887	.4604	.2900	.4624	.2913	.4644	.2927	.4664	.2940	.4683	.2953	.4703
66	.2966	.4722	.2980	.4742	.2993	.4761	.3006	.4780	.3020	.4799	.3033	.4819
67	.3046	.4838	.3060	.4857	.3073	.4876	.3087	.4895	.3100	.4914	.3113	.4932
68	.3127	.4951	.3140	.4970	.3154	.4989	.3167	.5007	.3181	.5026	.3195	.5044
69	.3208	.5063	.3222	.5081	.3235	.5099	.3249	.5117	.3263	.5136	.3276	.5154
70	.3290	.5172	.3304	.5190	.3317	.5208	.3331	.5226	.3345	.5244	.3358	.5261
71	.3372	.5279	.3386	.5297	.3400	.5314	.3413	.5332	.3427	.5349	.3441	.5367
72	.3455	.5384	.3469	.5402	.3483	.5419	.3496	.5436	.3510	.5454	.3524	.5471
73	.3538	.5488	.3552	.5505	.3566	.5522	.3580	.5539	.3594	.5556	.3608	.5572
74	.3622	.5589	.3636	.5606	.3650	.5623	.3664	.5639	.3678	.5656	.3692	.5672
75	.3706	.5689	.3720	.5705	.3734	.5722	.3748	.5738	.3762	.5754	.3776	.5771
76	.3790	.5787	.3805	.5803	.3819	.5819	.3833	.5835	.3847	.5851	.3861	.5867
77	.3875	.5883	.3889	.5899	.3904	.5915	.3918	.5930	.3932	.5946	.3946	.5962
78	.3960	.5977	.3975	.5993	.3989	.6009	.4003	.6024	.4017	.6039	.4032	.6055
79	.4046	.6070	.4060	.6086	.4075	.6101	.4089	.6116	.4103	.6131	.4117	.6146
80	.4132	.6161	.4146	.6176	.4160	.6191	.4175	.6206	.4189	.6221	.4203	.6236
81	.4218	.6251	.4232	.6266	.4247	.6280	.4261	.6295	.4275	.6310	.4290	.6324
82	.4304	.6339	.4319	.6353	.4333	.6368	.4347	.6382	.4362	.6397	.4376	.6411
83	.4391	.6425	.4405	.6440	.4420	.6454	.4434	.6468	.4448	.6482	.4463	.6496
84	.4477	.6510	.4492	.6524	.4506	.6538	.4521	.6552	.4535	.6566	.4550	.6580
85	.4564	.6594	.4579	.6607	.4593	.6621	.4608	.6635	.4622	.6648	.4637	.6662
86	.4651	.6676	.4666	.6689	.4680	.6703	.4695	.6716	.4709	.6730	.4724	.6743
87	.4738	.6756	.4753	.6770	.4767	.6783	.4782	.6796	.4796	.6809	.4811	.6822
88	.4826	.6835	.4840	.6848	.4855	.6862	.4869	.6875	.4884	.6887	.4898	.6900
89	.4913	.6913	.4927	.6926	.4942	.6939	.4956	.6952	.4971	.6964	.4985	.6977

TABLE 3. HAVERSINES (Con't)
(90° to 134°)

Note: Characteristics of the logarithms are omitted.

°	0'		10'		20'		30'		40'		50'	
	Nat	Log	Nat	Log	Nat	Log	Nat	Log	Nat	Log	Nat	Log
90	.5000	.6990	.5015	.7002	.5029	.7015	.5044	.7027	.5058	.7040	.5073	.7052
91	.5087	.7065	.5102	.7077	.5116	.7090	.5131	.7102	.5145	.7114	.5160	.7126
92	.5174	.7139	.5189	.7151	.5204	.7156	.5218	.7175	.5233	.7187	.5247	.7199
93	.5262	.7211	.5276	.7223	.5291	.7235	.5305	.7247	.5320	.7259	.5334	.7271
94	.5349	.7283	.5363	.7294	.5378	.7306	.5392	.7318	.5407	.7329	.5421	.7341
95	.5436	.7353	.5450	.7364	.5465	.7376	.5479	.7387	.5494	.7399	.5508	.7410
96	.5523	.7421	.5537	.7433	.5552	.7444	.5566	.7455	.5580	.7467	.5595	.7478
97	.5609	.7489	.5624	.7500	.5638	.7511	.5653	.7523	.5667	.7534	.5681	.7545
98	.5696	.7556	.5710	.7567	.5725	.7577	.5739	.7588	.5753	.7599	.5768	.7610
99	.5782	.7621	.5797	.7632	.5811	.7642	.5825	.7653	.5840	.7664	.5854	.7674
100	.5868	.7685	.5883	.7696	.5897	.7706	.5911	.7717	.5925	.7727	.5940	.7738
101	.5954	.7748	.5968	.7759	.5983	.7769	.5997	.7779	.6011	.7790	.6025	.7800
102	.6040	.7810	.6054	.7820	.6068	.7830	.6082	.7841	.6096	.7851	.6111	.7861
103	.6125	.7871	.6139	.7881	.6153	.7891	.6167	.7901	.6181	.7911	.6195	.7921
104	.6210	.7931	.6224	.7940	.6238	.7950	.6252	.7960	.6266	.7970	.6280	.7980
105	.6294	.7989	.6308	.7999	.6322	.8009	.6336	.8018	.6350	.8028	.6364	.8037
106	.6378	.8047	.6392	.8056	.6406	.8066	.6420	.8075	.6434	.8085	.6448	.8094
107	.6462	.8104	.6476	.8113	.6490	.8122	.6504	.8131	.6517	.8141	.6531	.8150
108	.6545	.8159	.6559	.8168	.6573	.8177	.6587	.8187	.6600	.8196	.6614	.8205
109	.6628	.8214	.6642	.8223	.6655	.8232	.6669	.8241	.6683	.8250	.6696	.8258
110	.6710	.8267	.6724	.8276	.6737	.8285	.6751	.8294	.6765	.8302	.6778	.8311
111	.6792	.8320	.6805	.8329	.6819	.8337	.6833	.8346	.6846	.8354	.6860	.8363
112	.6873	.8371	.6887	.8380	.6900	.8388	.6913	.8319	.6927	.8405	.6940	.8414
113	.6954	.8422	.6967	.8430	.6980	.8439	.6994	.8447	.7007	.8455	.7020	.8464
114	.7034	.8472	.7047	.8480	.7060	.8488	.7073	.8496	.7087	.8504	.7100	.8513
115	.7113	.8521	.7126	.8529	.7139	.8537	.7153	.8545	.7166	.8553	.7179	.8561
116	.7192	.8568	.7205	.8576	.7218	.8584	.7231	.8592	.7244	.8600	.7257	.8608
117	.7270	.8615	.7283	.8623	.7296	.8631	.7309	.8638	.7322	.8646	.7335	.8654
118	.7347	.8661	.7360	.8669	.7373	.8676	.7386	.8684	.7399	.8691	.7411	.8699
119	.7424	.8706	.7437	.8714	.7449	.8721	.7462	.8729	.7475	.8736	.7487	.8743
120	.7500	.8751	.7513	.8758	.7525	.8765	.7538	.8772	.7550	.8780	.7563	.8787
121	.7575	.8794	.7588	.8801	.7600	.8808	.7612	.8815	.7625	.8822	.7637	.8829
122	.7650	.8836	.7662	.8843	.7674	.8850	.7686	.8857	.7699	.8864	.7711	.8871
123	.7723	.8878	.7735	.8885	.7748	.8892	.7760	.8898	.7772	.8905	.7784	.8912
124	.7796	.8919	.7808	.8925	.7820	.8932	.7832	.8939	.7844	.8945	.7856	.8952
125	.7868	.8959	.7880	.8965	.7892	.8972	.7904	.8978	.7915	.8985	.7927	.8991
126	.7939	.8998	.7951	.9004	.7962	.9010	.7974	.9017	.7986	.9023	.7997	.9030
127	.8009	.9036	.8021	.9042	.8032	.9048	.8044	.9055	.8055	.9061	.8067	.9067
128	.8078	.9073	.8090	.9079	.8101	.9085	.8113	.9092	.8124	.9098	.8135	.9104
129	.8147	.9110	.8158	.9116	.8169	.9122	.8180	.9128	.8192	.9134	.8203	.9140
130	.8214	.9146	.8225	.9151	.8236	.9157	.8247	.9163	.8258	.9169	.8269	.9175
131	.8280	.9180	.8291	.9186	.8302	.9192	.8313	.9198	.8324	.9203	.8335	.9209
132	.8346	.9215	.8356	.9220	.8367	.9226	.8378	.9231	.8389	.9237	.8399	.9242
133	.8410	.9248	.8421	.9253	.8431	.9259	.8442	.9264	.8452	.9270	.8463	.9275
134	.8473	.9281	.8484	.9286	.8494	.9291	.8505	.9297	.8515	.9302	.8525	.9307

TABLE 3. HAVERSINES (Cont'd)
(135° to 180°)

Note: Characteristics of the logarithms are omitted.

°	0'		10'		20'		30'		40'		50'	
	Nat	Log	Nat	Log	Nat	Log	Nat	Log	Nat	Log	Nat	Log
135	.8536	.9312	.8546	.9318	.8556	.9323	.8566	.9328	.8576	.9333	.8587	.9338
136	.8597	.9343	.8607	.9348	.8617	.9353	.8627	.9359	.8637	.9364	.8647	.9369
137	.8657	.9374	.8667	.9379	.8677	.9383	.8686	.9388	.8696	.9393	.8706	.9398
138	.8716	.9403	.8725	.9408	.8735	.9413	.8745	.9417	.8754	.9422	.8764	.9427
139	.8774	.9432	.8783	.9436	.8793	.9441	.8802	.9446	.8811	.9450	.8821	.9455
140	.8830	.9460	.8840	.9464	.8849	.9469	.8858	.9473	.8867	.9478	.8877	.9482
141	.8886	.9487	.8895	.9491	.8904	.9496	.8913	.9500	.8922	.9505	.8931	.9509
142	.8940	.9513	.8949	.9518	.8958	.9522	.8967	.9526	.8976	.9531	.8984	.9535
143	.8993	.9539	.9002	.9543	.9011	.9548	.9019	.9552	.9028	.9556	.9037	.9560
144	.9045	.9564	.9054	.9568	.9062	.9572	.9071	.9576	.9079	.9580	.9087	.9584
145	.9096	.9588	.9104	.9592	.9112	.9596	.9121	.9600	.9129	.9604	.9137	.9608
146	.9145	.9612	.9153	.9616	.9161	.9620	.9169	.9623	.9177	.9627	.9185	.9631
147	.9193	.9635	.9201	.9638	.9209	.9642	.9217	.9646	.9225	.9650	.9233	.9653
148	.9240	.9657	.9248	.9660	.9256	.9664	.9263	.9668	.9271	.9671	.9278	.9675
149	.9286	.9678	.9293	.9682	.9301	.9685	.9308	.9689	.9316	.9692	.9323	.9695
150	.9330	.9699	.9337	.9702	.9345	.9706	.9352	.9709	.9359	.9712	.9366	.9716
151	.9373	.9719	.9380	.9722	.9387	.9725	.9394	.9729	.9401	.9732	.9408	.9735
152	.9415	.9738	.9422	.9741	.9428	.9744	.9435	.9747	.9442	.9751	.9448	.9754
153	.9455	.9757	.9462	.9760	.9468	.9763	.9475	.9766	.9481	.9769	.9488	.9772
154	.9494	.9774	.9500	.9777	.9507	.9780	.9513	.9783	.9519	.9786	.9525	.9789
155	.9532	.9792	.9538	.9794	.9544	.9797	.9550	.9800	.9556	.9803	.9562	.9805
156	.9568	.9808	.9574	.9811	.9579	.9813	.9585	.9816	.9591	.9819	.9597	.9821
157	.9603	.9824	.9608	.9826	.9614	.9829	.9619	.9831	.9625	.9834	.9630	.9836
158	.9636	.9839	.9641	.9841	.9647	.9844	.9652	.9846	.9657	.9849	.9663	.9851
159	.9668	.9853	.9673	.9856	.9678	.9858	.9683	.9860	.9688	.9863	.9693	.9865
160	.9698	.9867	.9703	.9869	.9708	.9871	.9713	.9874	.9718	.9876	.9723	.9878
161	.9728	.9880	.9732	.9882	.9737	.9884	.9742	.9886	.9746	.9888	.9751	.9890
162	.9755	.9892	.9760	.9894	.9764	.9896	.9769	.9898	.9773	.9900	.9777	.9902
163	.9782	.9904	.9786	.9906	.9790	.9908	.9794	.9910	.9798	.9911	.9802	.9913
164	.9806	.9915	.9810	.9917	.9814	.9919	.9818	.9920	.9822	.9922	.9826	.9924
165	.9830	.9925	.9833	.9927	.9837	.9929	.9841	.9930	.9844	.9932	.9848	.9933
166	.9851	.9935	.9855	.9937	.9858	.9938	.9862	.9940	.9865	.9941	.9869	.9943
167	.9872	.9944	.9875	.9945	.9878	.9947	.9881	.9948	.9885	.9950	.9888	.9951
168	.9891	.9952	.9894	.9954	.9897	.9955	.9900	.9956	.9903	.9957	.9905	.9959
169	.9908	.9960	.9911	.9961	.9914	.9962	.9916	.9963	.9919	.9965	.9921	.9966
170	.9924	.9967	.9927	.9968	.9929	.9969	.9931	.9970	.9934	.9971	.9936	.9972
171	.9938	.9973	.9941	.9974	.9943	.9975	.9945	.9976	.9947	.9977	.9949	.9978
172	.9951	.9979	.9953	.9980	.9955	.9981	.9957	.9981	.9959	.9982	.9961	.9983
173	.9963	.9984	.9964	.9985	.9966	.9985	.9968	.9986	.9969	.9987	.9971	.9987
174	.9973	.9988	.9974	.9989	.9976	.9989	.9977	.9990	.9978	.9991	.9980	.9991
175	.9981	.9992	.9982	.9992	.9983	.9993	.9985	.9993	.9986	.9994	.9987	.9994
176	.9988	.9995	.9989	.9995	.9990	.9996	.9991	.9996	.9992	.9996	.9992	.9997
177	.9993	.9997	.9994	.9997	.9995	.9998	.9995	.9998	.9996	.9998	.9996	.9998
178	.9997	.9999	.9997	.9999	.9998	.9999	.9998	.9999	.9999	.9999	.9999	.9999
179	.9999	.9999	.9999	.9999	1.0000	.0000	1.0000	.0000	1.0000	.0000	1.0000	.0000
180	1.0000	.0000										

BIBLIOGRAPHY

A detailed discussion of every aspect of the problems of frequency and time control, radio propagation, etc. is beyond the scope of this publication. The following selections provide additional information of interest to those engaged in maintaining precision frequency and time standards.

Marrison, W.A. "The Evolution of the Quartz Crystal Clock", Bell Systems Journal, vol. 27, pp. 510-588; July, 1948

Morgan, Alvin H. Precise Time Synchronization of Widely Separated Clocks, NBS Technical Note 22, Office of Technical Services, U.S. Department of Commerce, Washington 25, D.C.; July, 1959

Pierce, J.A. "Intercontinental Frequency Comparison by Very Low Frequency Radio Transmission", Proc. IRE, vol. 45, pp. 794-803; June, 1957

Richardson, John M. "National Standards of Time and Frequency in the United States", Proc. IRE, vol. 48, pp. 105-106; January, 1960

Shaul, J.M. "Adjustment of High-Precision Frequency and Time Standards", Proc. IRE, vol. 38, pp. 6-15; January, 1950

Ionospheric Radio Propagation, NBS Circular 462, U.S. Government Printing Office, Washington 25, D.C.; June, 1948

Naval Observatory Time Service, Circular No. 49, U.S. Naval Observatory, Washington 25, D.C.; March, 1954

"IRE Transactions on Instrumentation", Proc. IRE, vol. 1-9, no. 2; September, 1960

Proceedings of the 15th Annual Symposium on Frequency Control, U.S. Army Signal Research and Development Laboratory, Fort Monmouth, N. J.; May-June, 1961

Watt, A.D., et. al. World-Wide Standard Frequency and Time Signal Broadcasting, NBS Report 6091, U.S. Department of Commerce, National Bureau of Standards, Boulder, Colo.; March, 1960

Essen, L. "The International Co-ordination of Time Signals and Standard Frequency Transmissions", Nature, vol. 187, no. 4736, pp. 452-453; August 6, 1960

Beder and Hinkler "World Wide Clock Synchronization", IRE Transactions on Military Electronics, vol. MIL-4, nos. 2-3, pp. 366-376, April-July, 1960

Reder, F.H., et.al, "Results of a Long-Range Clock Synchronization Experiment", Proc. IRE, vol. 49, pp. 1028-1032; June, 1961

APPENDIX IV
HEWLETT-PACKARD REPRESENTATIVES AND OFFICES

Sales and Service Representatives in North America

+ Indicates Instrument Repair Stations

EASTERN SEABOARD

Asbury Park, New Jersey
The I. E. Robinson Company
1317 Railroad Avenue
KELlog 1-3150

Baltimore 15, Maryland
Horman Associates, Inc.
3006 West Cold Spring Lane
MOHawk 4-4400

+ Boston Area
Burlington, Massachusetts
Yewell Associates, Inc.
Middlesex Turnpike
BRowning 2-9000

Bridgeport 8, Connecticut
Yewell Associates, Inc.
1101 East Main Street
FOREst 6-3456

Camp Hill, Pennsylvania
The I. E. Robinson Company
Park Place Office Bldg.
REGent 7-6791

Englewood, New Jersey
R. M. C. Associates
391 Grand Avenue
LOWell 7-3933

+ New York 21, New York
R. M. C. Associates
236 East 75th Street
TKafalgar 9-2023

+ Philadelphia Area
West Conshohocken, Pennsylvania
The I. E. Robinson Company
144 Elizabeth Street
CHEstnut Hill 8-1600
TAYlor 8-6200

+ Pittsburgh 27, Pennsylvania
S. Sterling Company
4322 Brownsville Rd.
TUxedo 4-5515

Poughkeepsie, N. Y.
Yewell Associates, Inc.
806 Main Street
GROver 1-3456

+ Rochester 25, New York
Edward A. Ossmann & Associates
830 Linden Avenue
LUdlow 6-4940

Syracuse, New York
Edward A. Ossmann & Associates
101 Picard Drive, P. O. Box 128
GL 4-2461

Vestal, New York
Edward A. Ossmann & Associates
149 Front St.
STillwell 5-0296

+ Washington, D. C. Area
Rockville, Maryland
Horman Associates, Inc.
941 Rollins Avenue
HAzewood 7-7560

SOUTHEASTERN STATES

+ Atlanta 5, Georgia
Bivins & Caldwell, Inc.
3110 Maple Drive, N. E.
233-1141, Area Code 404

+ High Point, North Carolina
Bivins & Caldwell, Inc.
1923 N. Main Street
882-6873

Huntsville, Alabama
Bivins & Caldwell, Inc.
534-5733
(Direct line to Atlanta)

+ Orlando, Florida
Stiles Associates, Inc.
61 Commonwealth Ave.,
P.O. Box 6115
GARDen 5-5341

Richmond 30, Virginia
Bivins & Caldwell, Inc.
1219 High Point Ave.
ELGin 5-7931

St. Petersburg 8, Florida
Stiles Associates, Inc.
410-150th Ave., Madeira Beach
391-0211

CENTRAL, SOUTH CENTRAL STATES

+ Chicago 45, Illinois
Crossley Associates, Inc.
2501 West Peterson Ave.
BROADway 5-1600

+ Cleveland 24, Ohio
S. Sterling Company
5827 Mayfield Road
HILLcrest 2-8080

+ Dallas 9, Texas
Earl Lipscomb Associates
P. O. Box 7084
FLEetwood 7-1881 and
EDison 2-6667

+ Dayton 19, Ohio
Crossley Associates, Inc.
2801 Far Hills Avenue
AXMinster 9-3594

+ Detroit 35, Michigan
S. Sterling Company
15310 West McNichols Rd.
BROADway 3-2900

+ Houston 5, Texas
Earl Lipscomb Associates
P. O. Box 6646
MOHawk 7-2407

+ Indianapolis 5, Indiana
Crossley Associates, Inc.
3919 Meadows Dr.
LIBerty 6-4891

Kansas City 30, Missouri
Harris-Hanson Company
7916 Paseo Blvd.
HILLand 4-9494

+ St. Louis 17, Missouri
Harris-Hanson Company
2814 South Brentwood Blvd.
MISSION 7-4350

+ St. Paul 14, Minnesota
Crossley Associates, Inc.
842 Raymond Avenue
MIDway 6-7881

WESTERN STATES

+ Albuquerque, New Mexico
Neely Enterprises
6501 Lomas Blvd., N. E.
255-5586

+ Denver 10, Colorado
Lahana & Company
1886 South Broadway
PEARl 3-3791

Las Cruces, New Mexico
Neely Enterprises
114 S. Water Street
526-2486

+ Los Angeles, California
Neely Enterprises
3939 Lankershim Blvd.
North Hollywood, Calif.
TRIangle 7-1282 and
POPlar 6-3811

Portland 9, Oregon
ARVA, Inc.
1238 N. W. Glisan
CAPitol 2-7337

+ Sacramento 14, California
Neely Enterprises
1317 - 15th Street
GILbert 2-8901

+ Salt Lake City 15, Utah
Lahana & Co.
1482 Major St.
HUnter 6-8166

+ San Diego 6, California
Neely Enterprises
1055 Shafter Street
ACAdemy 3-8103

+ San Francisco Area
San Carlos, California
Neely Enterprises
501 Laurel Street
591-7661

Scottsdale, Arizona
Neely Enterprises
771 So. Scottsdale Rd.
945-7601

+ Seattle 9, Washington
ARVA, Inc.
1320 Prospect Street
MAIN 2-0177

Tucson, Arizona
Neely Enterprises
232 So. Tucson Blvd.
MAIN 3-2564

CANADA

+ Montreal, Quebec
Hewlett-Packard (Canada) Ltd.
8270 Mayrand Street
Telephone: 735-2273

Ottawa, Ontario
Hewlett-Packard (Canada) Ltd.
1762 Carling Avenue
Parkway 2-8162

Toronto, Ontario
Hewlett-Packard (Canada) Ltd.
1415 Lawrence Avenue W.
Telephone: 249-9196

Sales and Service Representatives Overseas

+ Indicates Instrument Repair Stations

Argentina

Mauricio A. Suarez
Telecomunicaciones
Carlos Calvo 224, Buenos Aires
Tel. 30-6312-34-9087

+ Australia

Sample Electronics
(N.S.W.) Pty. Ltd.
48 Chippen Street, Sydney
Tel: 69-4112 and 69-6338
Sample Electronics (Vic.) Pty. Ltd.
9-11 Cremorne Street,
Richmond, E. 1, Victoria
Phones: 42-4757 (3 lines)

Austria

Austronik G. m. b. H.
54 Mollardgasse, Vienna VI
Tel: 57.06.38

+ Belgium

Electronique Marketing Co., S.A.
20-24 rue de l'Hopital, Brussels
Tel: 11.22.20

+ Denmark

Tage Olsen A/S
Centrumgården, Room 133
6D, Vesterbrogade, Copenhagen V.
Tel: Palae 1369 and Palae 1343

Finland

INTO O/Y
11 Meritullinkatu, Helsinki
Tel: 62 14 25 and 35 125

+ France

Radio Equipements
65 rue de Richelieu, Paris 28me
Tel: RIChelieu 49-88, 50-78
95-41

+ Germany

Hewlett-Packard
Vertriebsgesellschaft m. b. H.
Sophienstrasse 8
Frankfurt am Main
Telefon 77-31-75 and 77-94-25

Moorweidenstrasse 12
Hamburg
Tel: 45 43 33

Severinstrasse 5
München
Tel: über 49 58 71

Greece

K. Karayannis
Karitsi Square, Athens
Tel: 23-213 (15 Lines)

India

The Scientific Instrument
Company, Ltd.
6, Tej Bahadur Sapru Road
Allahabad 1

India (Continued)

240, Dr. Dadabhai Naoroji Road
Bombay 1

11, Esplanade East, Calcutta 1
30, Mount Road, Madras 2
B-7, Ajmeri Gate Extn.
New Delhi 1

Israel

Electronics & Engineering Ltd.
6 Feierberg St., Tel-Aviv
Phone 64288

+ Italy

Dott. Ing. Mario Vianello
Via. L. Anelli 13, Milano
Telef. 553-081 and 553-811
Via S Croce in Gerusalemme 97,
Rome
Telef. 767-230 and 767-941

+ Japan

Seki & Company, Ltd.
Daini Taihei Building
No. 1 Kanda Higashi-Fukudacho
Chiyoda-Ku, Tokyo
Tokyo (866) 3136-9
Osaka Branch Office
Sumi Bldg., 106 Umegaecho
Kita-ku, Osaka
Tel: (312) 2731, 0759

Korea

American Trading Company, Inc.
178 1st Ka, Euijoo-Ro
Sudaimoon-Ku, Seoul
Telephone: 3-4838, 3-7049, 3-7613

+ Netherlands

Electronic Marketing Co., N.V.
23, Burg. Roellstraat
Amsterdam W.
Tel: 13.28.98

New Zealand

Geo. H. Sample & Son (N.Z.) Ltd.
431 Mount Albert Road
Mount Roskill, Auckland, S3
Tel: 898-439

+ Norway

Morgenstjerne & Co.
Wessels Gate 6, Oslo
Tel. 42 99 93

Portugal

Senatejo Industrial, Lda.
Rua do Alecrim, 46-S/Loja
Lisbonne 2
Tel: 3 44 46 - Bureau
36 86 43 - Direction

South Africa

F. H. Flanter & Co., (Pty.), Ltd.
Rosella House
Buitensingle Street, Cape Town
Tel. 3-3817

Spain

ATAIO, Ingenieros
A. Aguilera, No. 8
Madrid 15
Tel: 223-27-42
254-53-80

+ Sweden

Erik Ferner, AB
Snörmakarvägen 35
Bromma 1
Tel: 252870

+ Switzerland

Max Paul Frey
Hangweg 27
Köniz - Bern
Tel: (031) 63 36 44

Taiwan (Formosa)

Hwa Sheng Electronic Co., Ltd.
21 Nanking West Road, Taipei
Telephone: 4-6076

+ United Kingdom

Livingston Laboratories Ltd.
31 Camden Road
London N.W.
Tel: Archway 6521

Yugoslavia

Belram Electronics
83 Av. Des Mimosas
Brussels 15, Belgium
Tel: 35 . 29 . 58



Registered Trademark of the Hewlett-Packard Company