



CHARACTERISTICS AND USE OF  SAMPLING OSCILLOSCOPE PROBE AND ACCESSORIES

INTRODUCTION

The operating controls and adjustments on the  185B Sampling Oscilloscope are straightforward, resembling those found on conventional oscilloscopes. However, the sampling system and the very high frequency response that it makes possible creates a need for good measuring technique and care in the application of accessories.

Ideally, a versatile measuring device such as an oscilloscope should not load or otherwise affect the system or circuit to which it is connected, nor should it require that the measured circuit be modified or adapted to any special configuration or impedance level. This suggests a high impedance probe type input. It must be recognized, however, that the bandwidth afforded by the sampling technique is such that any small distributed inductances and capacitances in the probe can cause the measured waveform to be distorted by ringing or deteriorated by loading. Shunt capacity should be held to a minimum and, although signal source impedances at these frequencies are usually low, it is desirable to have a high input resistance in order to avoid upsetting the DC biasing system of the circuit being measured.

This note describes the  Balanced Sampling Gate with feedback and the high impedance probe that it makes possible. It also describes the family of sampling probe accessories which increase measurement convenience. With these fundamentals in mind, this application information will help you understand the measurement considerations and select the proper accessory for best performance.

BALANCED SAMPLING GATE



The balanced sampling gate with feedback was developed by  to overcome a number of restrictions and problems inherent in simpler single-sided gating systems. The result of this development is a probe which offers high input impedance, effectively 100% sampling efficiency, and a high degree of suppression of sampling pulses emitted into the external circuit.

Figure 1 is a simplified sketch of the sampling circuit, drawn to emphasize the care that has gone into balancing the gate. Briefly the circuit works as follows: All diodes are back-biased until the sampling pulses turn them on and off very rapidly and in synchronism.

They must conduct equally and simultaneously to insure cancellation of the gating pulse at the probe tip. Note that this is accomplished by correct adjustment (bias centering) of point A2 which is related, through coupling to the feedback branch, to the charge stored at A3. In turn, the level at A3 is the last sampled level of A1 as held by feedback from the stretcher. The overall result is that the gate is balanced around the last sample level. In addition to the bias centering adjust and careful equalizing of the size and shape of the sampling pulses, a number of further matching and balancing steps are taken in order to minimize the residual sampling pulse appearing at the probe tip.

Model 187B sampling plug-ins Serial No. 325-01469 and above have probes that are also capacitively balanced by the addition of a short piece of wire to increase the capacity across CR1. (Which is selected to have the lower capacity of the 2 input diodes). Field modification of plug-ins with lower serial numbers is covered in  Service Note 187B-5 and the modification must be made if the Model 10213A Sampling Probe Isolator accessory is to be used. The result of this careful balancing is that the residual pulse at the probe tip is made so small that it is unlikely to cause any trouble in the external circuit. The nature of the residual pulse is that it is preset only when the diodes are conducting. Looking back into the gate, it appears to come from a high impedance source. This means that the voltage developed across the input by this pulse at the instant of sampling is a function of the measured circuit impedance. Therefore a base line shift can occur as the probe is touched to measuring points which have varying source impedances. Although the base line can always be restored for a given measurement, several accessories which eliminate the need for readjustment are available. These will be discussed later.

Another consideration that enters into the design of the balanced sampling gate and its feedback circuitry is sampling efficiency. Referring to Figure 1, it is seen that when the diodes are conducting, the only impedance between the signal source and A3 is that of the conducting diodes in series with the combination of the probe input impedance and the source impedance of the signal being measured. Therefore, the sampling efficiency must be related to the impedance to the left of A1. The feedback is so arranged that while the sampling efficiency without feedback is approximately

01694-1

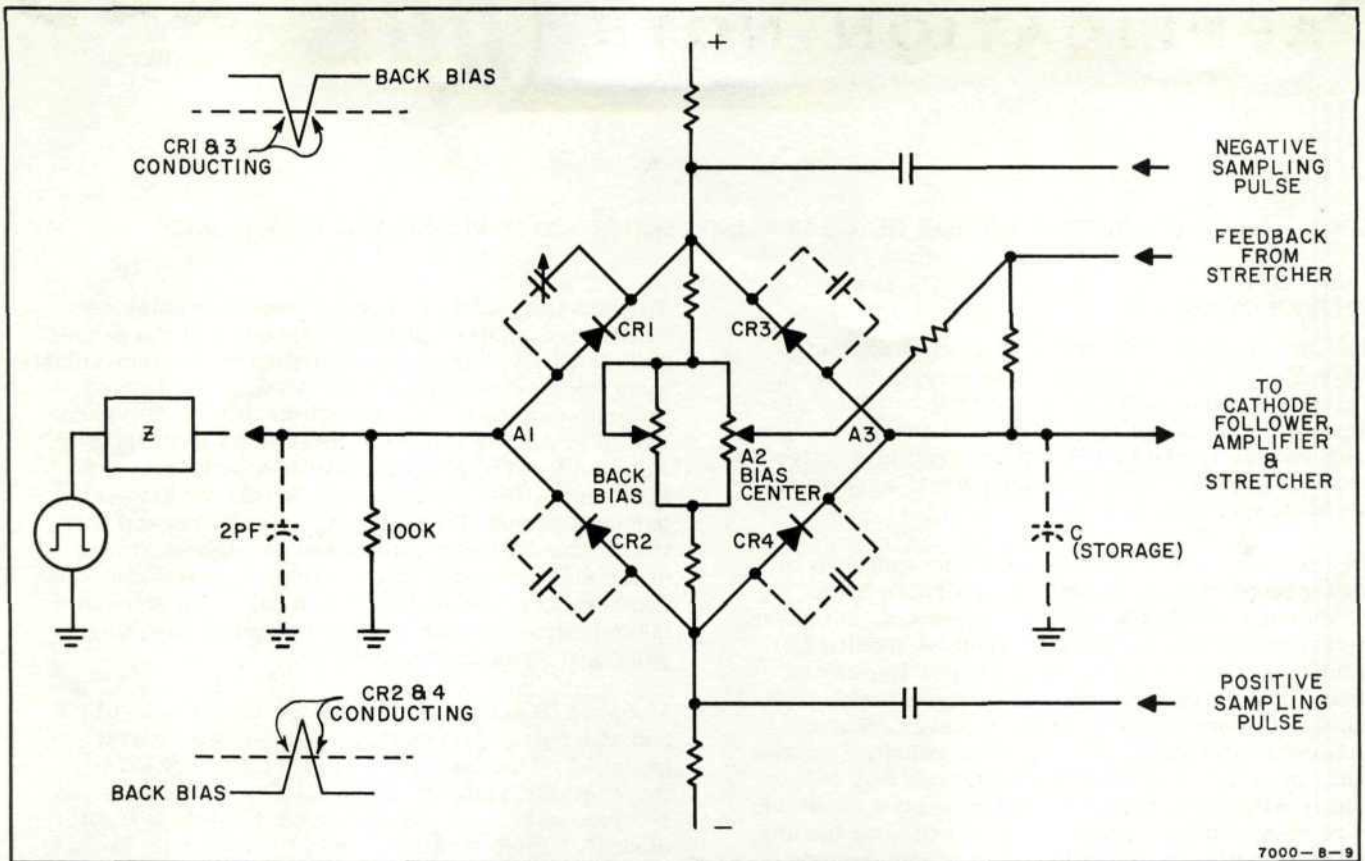

Figure 1. Simplified Diagram of Φ Balanced Sampling Gate

25%, the overall efficiency with feedback will be exactly 100%. To compensate for changes in sampling efficiency as a function of the source impedance of the device being measured an adjustment is provided to control the length of time that the diodes are conducting. This is called "response adjust," but actually it is the back-bias control which sets the base line for the sampling pulses, thereby controlling the length of time that the diodes are forward biased. Since the rise time of the sampling system is determined by the length of the sampling period, low source impedances which increase efficiency and therefore reduce the sampling period will result in the fastest measuring rise times. If the impedance of the signal source is greater than several hundred ohms and shunt capacity is low (a few pf), the response adjust will not normally bring the overall efficiency to fully 100%. As explained in the manual, this will not affect the accuracy of measurement if the sample density along the waveform is high (i. e., sweep speed fast compared to slope of waveform).

If the fixed input impedance to the gate were made low, the problems of suppressing the residual sampling pulse and of adjusting the efficiency of sampling would be overcome. However, this would result in a device limited to some low input impedance. In order to facilitate probing in active circuits having varying signal source impedances with minimum loading of either the signal or the DC biasing and power supply system, Φ has chosen to build a probe

having 100,000 ohms input resistance shunted by a minimum capacity of approximately 2 pf. Several of the accessories for high impedance probing to be described isolate the input to the sampling gate from the source impedance of the waveform being measured so that no base line or response adjustment is required when going from one measuring impedance to another. Finally, starting with a high impedance probe makes it possible to provide a family of accessories so that bridging measurements may be made in low impedance coaxial systems as well as in active circuits and networks.

THE SAMPLING PROBE ISOLATOR

The diodes in the sampling gate are conducting for such a very short time that the residual sampling pulse is only concerned with impedances right across the input to the probe. If the signal is measured through a section of transmission line long enough that the reflection from a non-matched impedance at its other end is not received at the probe input by the time the diodes have stopped conducting, there will be no effect on the base line regardless of what impedance terminates the transmission line. The trace remains fixed as though a lumped impedance equal to the characteristic impedance of the transmission line section were placed across the probe input. Again, because the diodes conduct for such a very short time, a piece of air line just over 2 inches long is adequate to provide this isolation. Following the same line of

reasoning, the efficiency or response of the sampling gate is also not affected by an impedance across the transmission line that is too far down the line to deliver current through the gate during the brief time that it is conducting.

These interesting facts provide the basics for an isolator accessory. The accessory simply consists of a probe tip and several inches of rigid transmission line having a characteristic impedance of 200 ohms (see Figure 2). The back end of the isolator fits over the basic sampling probe. Since there is a possibility of multiple reflections of a very fast input pulse along the line, the center conductor has been loaded by 200 ohms in series so that the system appears matched at frequencies high enough to produce reflection on the very short line section involved. The line is short enough that for input signals within the response of the probe and isolator combination it simply looks like an added 2 pf capacity in parallel with the approximately 2 pf of the basic probe.

With the isolator installed on the probe the 187B response cannot be adjusted for 100% efficiency. The correct setting of the response control with the isolator is for 50%. In other words, the second dot should be set half way between the first dot (level at the end of the display) and the level at the beginning of the true display. This means that with the isolator the response is 50% smoothed. Caution must be observed with waveforms where each recurrence is not the same, such as pulse trains with sometimes missing pulses, that the display is not misinterpreted, just as with usual smoothing. Also, the scan density should be sufficient to allow at least 10 samples to occur on a rise time to prevent errors in rise time measurement, just as with usual smoothing. As a practical matter, at maximum scan density no errors will be caused in rise time measurements due to this effect. With the correct setting the probe and isolator combination has a risetime of 0.5 nsec. (For further information see Model 10213A Operating Note).

HIGH IMPEDANCE PROBE DIVIDERS

The Model 10202B 10:1 Divider and the 10203A 100:1 Divider also provide the isolating function in addition to changing the sensitivity range of the oscilloscope. Since these are conventional resistance dividers with capacity compensation, the high impedance section of the divider appears to be in series with the impedance of the device being measured as far as the input to the probe is concerned. Since this upper impedance is nominally 9 or 99 times greater than the input impedance to the probe, it has very little shunting effect regardless of the impedance to which it is connected (see Figure 3). Accordingly, when these dividers are installed on the probe, the need for base line and response adjustment as a function of source impedance is eliminated. Although the series elements of the dividers are high impedance, they have fairly large shunt capacities on the tail end to provide the necessary division ratios. Therefore impedance at the gate input is low and sampling efficiency is high so that the correct response adjustment results in short gate time and rise time with the dividers is high.

In the case of both dividers, the DC component of the probe's input impedance is multiplied by the division ratio, which makes probing with these dividers even less likely to upset the DC distribution in the circuit under test. The input shunt capacity exhibited by the 10:1 Divider is very nearly the same as that for the bare probe, but in the case of the 100:1 Divider the input capacity is reduced to 1 pf. For greatest convenience, one of the dividers or the isolator should be used for probing whenever possible.

PROBING TECHNIQUE

Probing in fast rise time circuits and systems with the hp 187B Sampling Probe and its accessories requires some consideration of the source impedance of the signal at the point of probing and how this compares

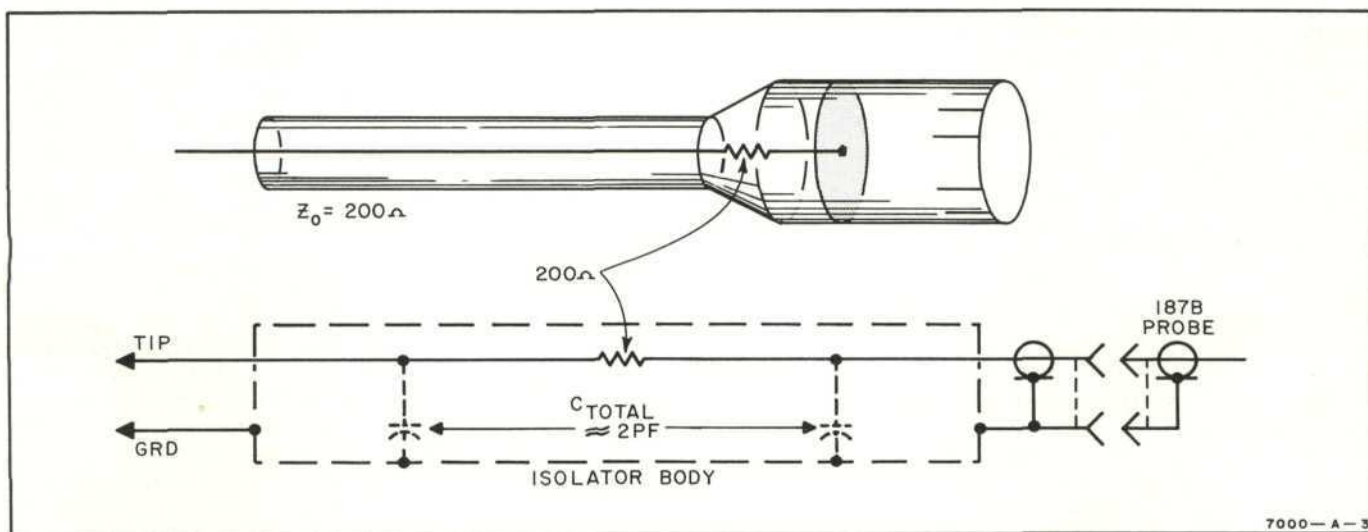

Figure 2. Sampling Probe Isolator

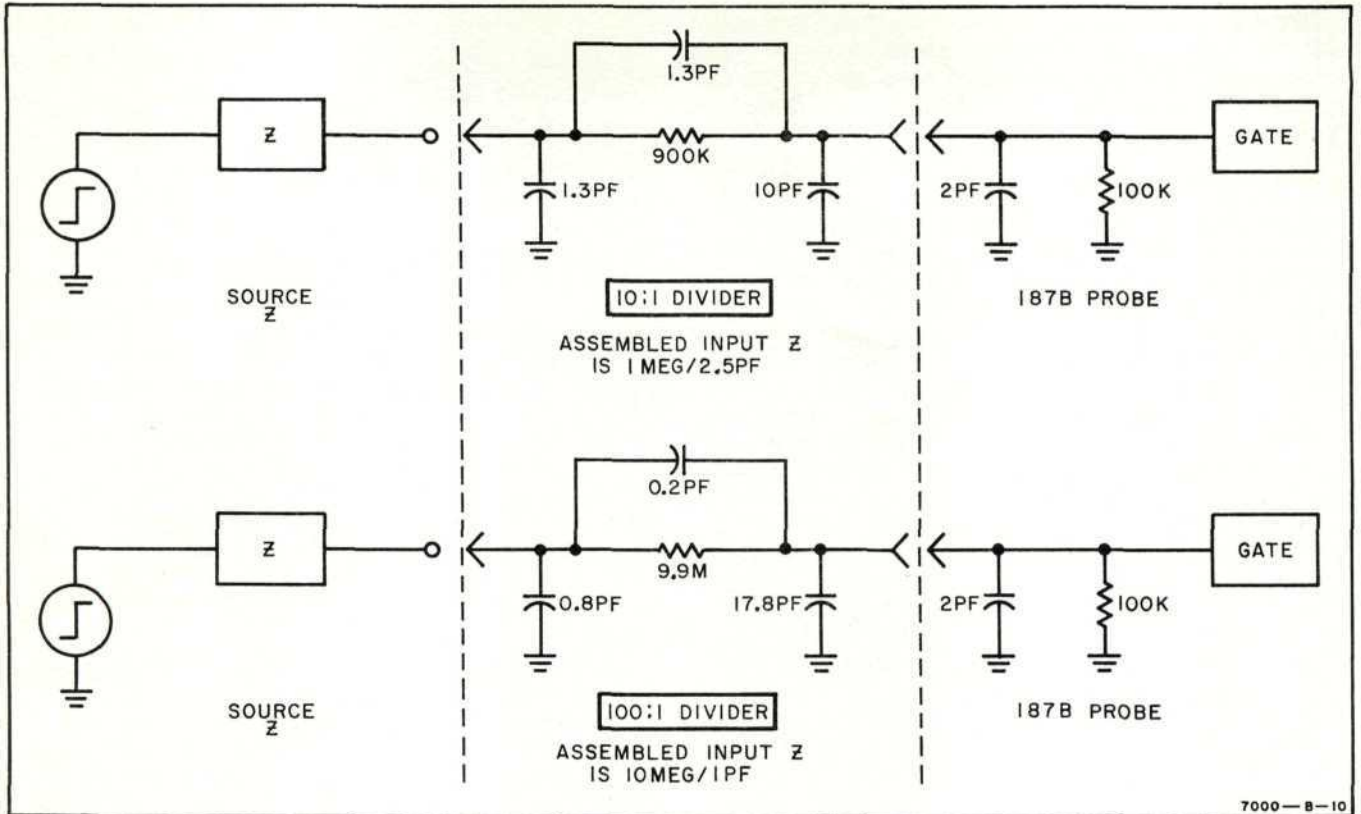

Figure 3. High Impedance Dividers

to the input impedance of the probe or whatever accessory is in use. In both cases the impedances are usually rather complex. Although an exhaustive analysis of the various effects of these impedances upon the measured waveform is not in order, it does seem worthwhile to review the most important general considerations. Figure 4 shows a generalized signal source in which the waveform appears to come from a zero impedance generator through a source resistance R_s . Although there is usually a small amount of inductance in the circuit, it is generally true that the apparent source impedance exhibits a net shunt capacity to ground. Since ideally the probe should not affect the waveform in any way, the magnitude of this shunt capacity of the probe or its accessory is of considerable interest.

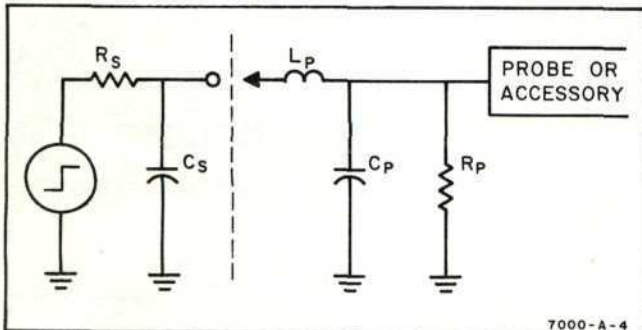

Figure 4. Generalized Source and Probing Impedances

In the case of the generalized input impedance for the probe or its accessories, the inductance is shown only in recognition of the possibility of ringing. For purposes of analyzing the probing situation, Table I gives the apparent input impedance of the accessories, when attached to the probe, in terms of input resistance and shunt capacity.

The two important possible causes of waveform distortion when probing are ringing and loading, and it is always of interest to determine whether or not these effects are caused by the probe. Considerable information can be gained by simple analysis if the impedances involved are reduced to the simplified circuit of Figure 4. In addition, reviewing waveforms based on signal sources having known wave shapes and source impedances will provide further insight. A rather extensive log of these waveforms is published at the end of this note and will be referred to in the following discussion.

In the matter of ringing, there are several important considerations. First, if the probe inductance and capacitance combination can be made so that the frequency at which they might ring is beyond the bandwidth of the scope, there is no problem. It is this fact that suggests that good probing technique be used in order that the inductance be held to an absolute minimum. A good deal of the apparent inductance can come from the probe grounding arrangement. Ideally, the probe case should be firmly in contact with the nearest ground plane to the test point. The addition of the small spring loaded ground pins to the

probe add enough inductance that the ringing frequency can come within the bandwidth of the oscilloscope. If, for convenience, the user attempts to connect a ground lead or pigtail to the probe, the inductance is so large that the ringing frequency is brought well into the bandwidth of the scope and can be very troublesome.

Assuming that inductance has been minimized by good probe handling and that even then the ringing frequency is within the bandwidth of the scope, there are other considerations which affect its magnitude. From Figure 4 the Q of the ringing circuit is dependent on the signal source resistance R_s . If the source resistance is high, the Q of the circuit is low and the circuit will be damped. Finally, the amount of ringing depends upon the presence of frequency components at the ring frequency in the input waveform. Reference to waveforms in Table II shows that with good probing practice the probe will still ring at a frequency toward the upper limit of the bandwidth of the scope. However, this requires an input rise time that is faster than the rise time of the scope itself and also a low source resistance. Reducing the rise time or increasing the source resistance considerably reduces or eliminates this ringing. In a practical sense then, it is not likely that ringing will be a problem in the case of measuring rise times within the capability of the scope so long as care is taken to keep the probing circuit inductance low.

Capacity loading is also of considerable importance. Again referring to Figure 4, there appears to be a contest between C_s and C_p . First it must be determined if the presence of both shunt capacities is deteriorating the waveform. If the waveform generator has zero rise time, then the waveform as seen on the scope should be scrutinized for the telltale signs of an exponential rise. If such is the case, then quite obviously the shunt capacities are suspect and the matter becomes one of determining how much C_p contributes to the deterioration of the waveform at the test point. Rise time for exponentials is usually considered to be the time that it takes the waveform to reach 90% of full value. The common expression for this is:

$$R_t = 2.2 \times R_s \times C_p$$

In the formula the subscripts "s" and "p" are used because they describe the maximum rise time that could be expected assuming C_s was vanishingly small.

As an example, consider the case of the probe alone which has an input capacity of approximately 2 pf's. If R_s is chosen at 200 ohms, the calculated rise time is 0.88 nsec assuming that the waveform generator has negligible rise time. Now consider that in practical systems C_s is not vanishingly small. In fact, in the case of transistor circuitry where capacities run from 1 to 4 pf for the device alone and to which is added the shunt capacities of both the output circuitry and the input elements of the following stage, C_s might commonly be expected to be in the order of 10pf. Under these conditions, the shunting effect of C_p

at 2 pf is 20%. Rise time in the circuit itself might be about 2 nsec maximum. As a general rule then, it is safe to assume that if the rise time as calculated by the foregoing expression is small compared to the rise time viewed, the probe or accessory in use is not appreciably affecting the rise time of the measured signal. Table I gives the input capacity for each of the accessories.

BRIDGING VS. TERMINATING IN COAXIAL SYSTEMS.

A rather simple and obvious means of avoiding the necessity of response and base line adjustments is to reduce the probe input impedance to some very low value. The only reasonable choice is 50 ohms since the majority of coaxial transmission systems are designed with a 50-ohm characteristic impedance. This solution is appealing until it is recognized that a permanent 50-ohm input impedance to the sampling gate would terminate every waveform at the point of measurement. Further, such a course would eliminate the possibility of very high impedance probing as described above unless a cathode follower (which has limited dynamic range and high shunt capacity) were employed. Accordingly, the hp sampling probe and accessory system has been specially designed so that convenient measurements may be made in 50 ohm systems by the use of accessories, instead of limiting the versatility of the basic probe to the 50-ohm level. Of particular importance is that the probe may be used in a 50-ohm bridging configuration so that the signal is terminated at the option of the user. Years of experience with the hp 410 series of RF Voltmeters and their accessory tees have firmly established the advantages of bridging-type measurement in transmission line systems. The hp Model 10204B 50-ohm tee allows the probe to sample the waveform on a 50 ohm line with minimum shunting and insertion loss. The only mismatch caused by placing the tee in the system and inserting the 187B probe is that created by the low shunting capacity of the basic probe. In the worst case, the reflection from a step input at the point of bridging would be an inverted pulse less than 0.5 ns wide and less than 25% of the step input height.

50-OHM MEASURING WITH THE BRIDGING TEE.

Perhaps the most ideal case for measuring very fast rise time phenomena is that depicted in Figure 5. In this case, the waveform generator again has zero rise time and a source impedance. This source is connected to a load Z_L through a coaxial transmission line, Z_0 . If the probe tip touches the center conductor of the coax, the likelihood of ringing is high because the probe sees a 50 ohm load in both directions, and therefore the source impedance is a low 25 ohms. It is likely that the mechanics of touching the center conductor will require such a long probe tip that L_p may be increased to the point where the ringing frequency is within the bandwidth of the scope. Obviously, this must be eliminated by the probe and its accessories because the generalized system of Figure 5 is a very common one. As mentioned before, the idea of making

the probe input impedance 50 ohms is an appealing one until it is noted that this would require the removal of Z_L from the system in order to make a measurement.

A far more useful alternative is the use of the 50-ohm bridging tee. The tee is so constructed that the probe tip snuggles down into the center conductor in such a way that L_p is reduced to such a low value that the ringing frequency is far beyond the bandwidth of the scope. The bridging tee can be inserted anywhere in a 50-ohm coaxial system without disconnecting Z_s and Z_L .

Since the system of Figure 5 is so common and easily reproduced, it serves as the basis for the rise time specification of the scope, which is quoted as 0.35 nsec when the probe is in the bridging tee and measuring a rise time that is fast by comparison.

It is not always true that the source and load impedances are equal to the characteristic impedance of the transmission line connecting them. Again, the 50 ohm bridging tee makes it possible to analyze the system under test for the effect of such mismatches. In the previous comments regarding the isolator, the probe sees only the characteristic impedance of a transmission line that it is looking into, provided the section is more than several inches long. In the case of the tee, it will see one-half of the characteristic impedance when the proper transmission line is connected at both ends. Now if you wish to see the waveform on the transmission line when it is properly terminated, you may attach the hp Model 908 Coaxial Load to the output end of the tee and simply view the waveform on a terminated basis. Conversely, if you have a practical load which differs from 50 ohms, you have the privilege of connecting that load to the output of the tee and viewing the effect on the waveform as well as the reflection it produces. If the source impedance is not matched to the transmission line, a reflection from it will be seen on the scope presentation. This occurs because the bridging tee sends a small reflection back to the source which will be re-reflected unless the source is matched to the transmission line. This, however, causes no difficulty because the reflection can be located as far along the trace as desired by simply increasing the length of transmission line between the source and the probe. Considerable work has been done along this line and it has been reported by Hewlett-Packard in several articles and papers on the subject of Time Domain Reflectometry. These will be of considerable interest to those working with coaxial systems in which discontinuities or impedance changes are of interest.

SIGNAL DELAY SYSTEM

A great many possibilities exist for obtaining synchronized pre-triggers for the sampling oscilloscope. In addition to the recommendations made in the hp 185B Operating and Service Manual, practically all pulse generators have time adjustable trigger pulse outputs. Many circuits and systems can also be triggered from an external source such as the sync output of the hp 185B, which is ideal because it automatically locks the external circuit response to the oscilloscope system. However, there are some occasions in which it is really necessary to trigger

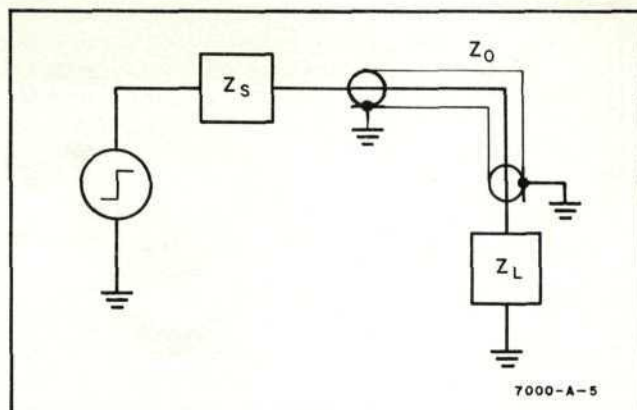

Figure 5. Generalized Coaxial System

the sampling scope from the incoming signal, and for this requirement the hp Model 1100A Delay Line System is available (see data sheet for individual accessory numbers).

The delay line system is a 50 ohm system. hp makes a series of resistive dividers which are based on a 50-ohm termination and this provides increased impedance for probing purposes when the delay line is necessary. The dividers are described below. The delay line provides a delay between the trigger input and the sampling gate so that triggering on the signal being viewed is possible. The delay line includes a 50-ohm sync take-off which splits the input signal into two parts. One part goes through a short sync cable to the sync input of the 185B oscilloscope, and the other goes down a 50-ohm delay line to a special delay line load. This load is equivalent to the bridging tee with a 50-ohm termination on it. However, to make up for the high frequency losses in the cable, a special compensating load has been designed, and therefore the tee and its special load have been combined into one compact unit. Overall rise time of the delay system is approximately .25 nsec, and therefore there is only about 10% increase in rise time for an input signal of 0.5 nsec rise time. The compensation is such that overshoot with the delay line system does not increase by more than 2% for rise times as fast as 0.5 nsec. Because the signal is split at the input, it is necessary to multiply the sensitivity calibration of the Model 187B plug-in by two.

LOW CAPACITY RESISTIVE DIVIDERS

There are occasions when even the low input capacity of the high impedance probe and its accessories can be troublesome. It is possible to reduce input capacity still further by the use of resistive dividers based on a termination of 50 ohms. In addition, these dividers can be used with the delay line system. The Model 10201A-D family of dividers have division ratios of 5, 10, 50, and 100:1. Accordingly, they offer input impedances of 250, 500, 2500, and 5000 ohms. In each case the input capacity is less than 0.4 pf, and this shunt capacity in conjunction with their short probe tip exhibits a ringing frequency beyond the bandwidth of the scope. Considerable care must be used when probing with these dividers to avoid upsetting

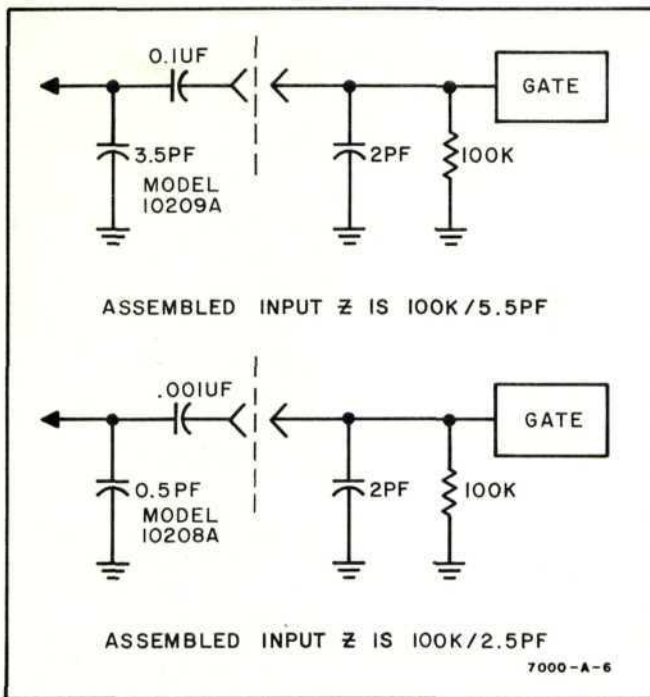

Figure 6. Blocking Capacitors

the DC biasing system of the circuit under test. The hp sampling accessory kit provides several blocking capacitors (described below) which may be used with these probes for DC isolation. These resistive dividers must be terminated in 50 ohms, and therefore they must be connected either to the bridging tee which in turn is terminated in 50 ohms, or to the delay line system. Connecting them directly to the probe by means of the BNC adapter fails to provide the necessary termination upon which their division ratio depends.

BLOCKING CAPACITORS

DC response is a requisite of a general-purpose pulse measuring instrument, and it is incorporated in the hp 185/187B Sampling Oscilloscope along with a great deal of zero or DC suppression. However, if a DC level is bothersome, then either the hp Model 10208A or 10209A blocking capacitor can be attached directly to the probe or "stacked" onto one of the dividers. The equivalent circuits are shown in Figure 6.

In applications where loading and rise time are critical, and the pulse width is not wide enough to cause sag problems, the .001 μf blocking capacitance should be used as it adds only 0.5 pf of shunt capacitance to the probe. On the other hand, where sag is a problem the 0.1 μf blocking capacitor should be used. The amount of sag that these blocking capacitors create is dependent upon the resistance into which they operate. Figure 7 shows approximate rise time for 1% and 5% sag as a function of the accessory to which the capacity is attached.

SINUSOIDAL SIGNALS

Most of the material contained in this Application Note deals with pulse applications. However, for working with sinusoidal signals the hp 185B/187B sampling scope has a frequency response above 1 kcm. A high frequency syncing position on the scope provides countdown for synchronization of high RF frequencies. All of the accessories used in pulse applications are also applicable for CW measurements. The bridging feature of the 50-ohm tee constitutes a real advantage for those not desiring to terminate their transmission line system in order to make a measurement.

ACCESSORIES AND KIT

Most of the commonly needed probe accessories are available in the hp Model 1102A Accessory Kit*. This kit provides a 10:1 divider and a blocking capacitor for each sampling probe of the two-channel hp 187B. It also equips one channel for bridging 50 Ω systems and provides a family of resistor dividers having very low shunt capacity. Included in the kit, at a reduced package price, are the following accessories:

Quantity	hp Model No.	Function
2	10202B	10:1 Divider
2	10208A	Blocking Capacitor (.001 μf)
1	10209A	Blocking Capacitor (0.1 μf)
1	10204B	50 ohm Tee
1	908A	50 ohm Coaxial Termination
1	10201A	5:1 Resistive Divider
1	10201B	10:1 Resistive Divider
1	10201C	50:1 Resistive Divider
1	10201D	100:1 Resistive Divider
1	10122A	Coaxial Cable Type N male to BNC female

In addition to these probe accessories, the new hp Model 10213A Isolator and the Model 10203A 100:1 Divider should also be purchased where high input impedance is important and signal level permits. Duplicate accessories such as the 50 Ω Tee, 50 Ω load, coaxial cable, and resistive dividers should be purchased separately if they are needed for the second channel. Refer to Tables I and III for a description of the hp sampling scope accessories and further information on their application.

FIXTURES AND HARDWARE

When the test signal is brought out to a coaxial fitting, such as a type N or BNC fitting, the appropriate adapter or the Bridging Tee is all that is required to transmit the signal to the oscilloscope. However, when the signal is developed across a resistor or other element inside the test circuit, the solution is not so easy. The importance of coupling as close as possible to the test point can be seen by studying the waveforms of Table II.

To provide a short clean signal path to the sampling gate of the probe, while at the same time facilitating easy probing, the high impedance probe employs a short low inductance probe pin in conjunction with a

* For complete description of each accessory see hp Model 1102A Technical Data Sheet

spring-loaded ground pin. Being spring-loaded the ground pin can adjust to minor variations in height and provide contact in close proximity to the test point thus avoiding high frequency loss and ground loop problems.

When it is inconvenient to physically hold the probe in position at the test point or when the pins will not span the gap, a number of alternatives are available.

- A. Replace the probe pins with clip leads. This is permissible as long as the lead inductance and stray capacitance do not cause overshoot and ringing. Resistance may be added to damp out any of these undesirable effects.
- B. Solder the probe pins to the test point. This alternative is electrically acceptable although it may be mechanically inconvenient.
- C. Utilize the 10210A Probe Socket. Whenever the test point is on a printed circuit board, it may be possible to mount the 10210A Probe Socket over the board to guide the probe into the test point position and provide a solid ground. This method is illustrated in Figure 8.
- D. Mount suitable connectors at the test point. If BNC or Type N connectors can be mounted at the test point, the signal can be viewed with the appropriate adapter. If these connectors are too large, miniature coaxial connectors of various types may be used. It is usually a simple matter to make a fitting to adapt the oscilloscope probe to other connector types. An example of an adapter for a Microdot Connector is shown in Figure 9.

MEASURING PROBLEMS AND SOLUTIONS

Table I lists the accessories that can be used to transmit the test signal to the oscilloscope input along with a summary of their important characteristics and advantages. Reference to this table, and Table II, will help in selecting the proper accessories for a particular measuring requirement. The following test circuit problems illustrate how they can be used:

- A. Circuit Conditions:
 - Rise Time = 10 nanoseconds
 - Circuit Impedance = 500 ohms
 - Signal Amplitude = 100 millivolts

Problem: It is desired to view two signals simultaneously and still be free to make adjustments on the test circuit.

Solution from Table I. To support the probes and leave the hands free to make circuit adjustments, the 10210A Probe Sockets should be used. Table I along with Table II indicates that both the basic 187B probe and the 10201D 5000-ohm Resistive Divider have sufficiently high impedance and rise time capability. However, the basic probe is more suitable because it provides higher sensitivity. At maximum gain, the 10201D 100:1 divider would provide only a 1/3 cm deflection for a 100 mv signal.

- B. Circuit Conditions:
 - Rise Time = 2.0 nanoseconds
 - Circuit Impedance = nominal 50 ohms

Problem: Test signal is brought to a BNC female connector through 6 inches of 50-ohm coaxial cable.

Solution: Depends on what is the normal termination for the 6 inches of cable. If it ordinarily goes to a 50 ohm load, then use 10204B 50 ohm Tee and an ϕ 908A 50 ohm load on one end with a 10120A, type "N" to BNC cable on the other. If it is ordinarily open circuit, then the 10207A BNC adapter would be indicated because this would be the highest available measuring impedance.

- C. Circuit Conditions:
 - Rise Time = 5 nanoseconds
 - Circuit Impedance = 100 ohms
 - Signal Amplitude = 10 volts p-p
 - Signal Duration = 100 nanoseconds

Problem: Test circuit is provided with DC bias from a 10K source, and hence is sensitive to DC loading.

Solution: Either the 187B 10:1, or 100:1 Dividers or the 10201A/B/C/D Resistive Dividers can sufficiently reduce the signal level for the 185B oscilloscope, and all are suitable from a rise-time standpoint. The 10201C 50:1 divider is the best of the latter group when sensitivity is reconciled with circuit loading. DC loading with the 10201C can be reduced by using a blocking capacitor. Since the signal duration is only 100 nsec the 10208A 0.001 μ f Blocking Capacitor would be the best choice as it has less shunt capacity. For longer duration signals the 10209A 0.1 μ f Blocking Capacitor would be more suitable since there is less sag. (See Figure 7.) A blocking capacitor is not needed with the 10:1 or 100:1 dividers as the DC impedance of these dividers are 1 and 10 megohms respectively.

- D. Circuit Conditions:
 - Rise Time = 2.0 nanoseconds
 - Circuit Impedance = 200 ohms
 - Signal Amplitude = 15 volts p-p

Problem: Test signal exists in a Type N connector.

Solution: Once again, either the 187B 10:1 and 100:1 Dividers or the 10201A/B/C/D Resistive Dividers are better suited because their lower shunt capacity results in less loading of the fast-rise test signal. (See Tables I and II). Either the 10201D or 10201C is suitable. The 10206A Type "N" and Probe Adapter may be used with the Resistive Divider to adapt it to the Type N fitting.

Blocking Capacitors	Percent Sag	10201A 5:1 Resistive Divider 250 Ω	10201B 10:1 Resistive Divider 500 Ω	10201C 50:1 Resistive Divider 2500 Ω	10201D 100:1 Resistive Divider 5000 Ω	187B Probe W or W/O 10213A Isolator 100 K	187B Probe 10202B 10:1 Divider 1 M	187B Probe 10203A 100:1 Divider 10 M
10208A (0.001 μf)	1%	2.5 nsec	5 nsec	25 nsec	50 nsec	1 μsec	10 μsec	100 μsec
	5%	13 nsec	26 nsec	130 nsec	260 nsec	5 μsec	50 μsec	500 μsec
10209A (0.1 μf)	1%	.25 μsec	.5 μsec	2.5 μsec	6 μsec	100 μsec	1 msec	10 msec
	5%	1.3 μsec	2.6 μsec	13 μsec	26 μsec	500 μsec	5 msec	50 msec

Figure 7. Sag for Blocking Capacitor and Other Accessory Combinations

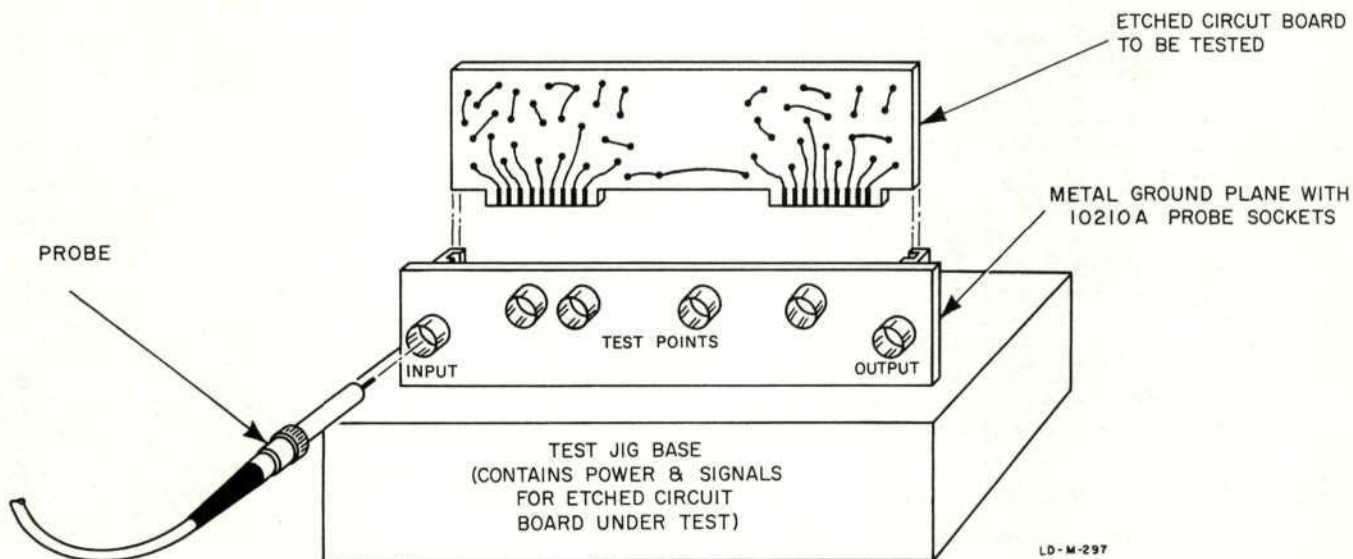

Figure 8. Use of 10210A Probe Socket in Production Test Jig

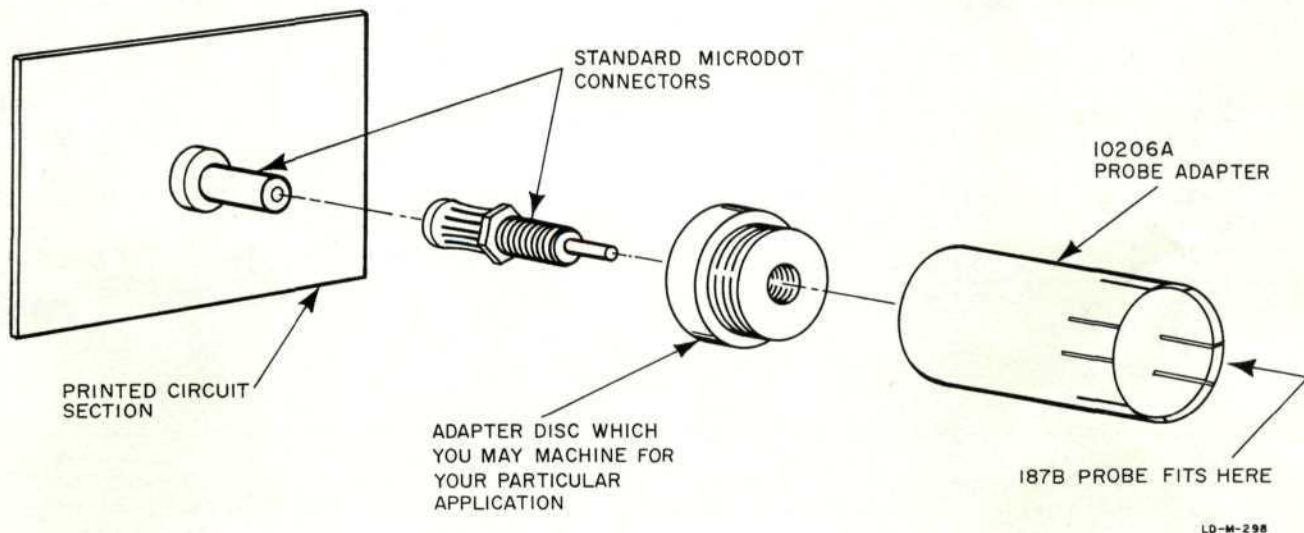

Figure 9. Use of 10206A Probe Adapter with Miniature Connectors

Table Ia High Impedance Sampling Accessories for μ 185B Sampling

Accessory	μ Model Number	Input Impedance/ Shunt Capacitance (with probe)	Range of Oscilloscope Sensitivity with Accessory	REMARKS- Waveforms in Table II demonstrate most of these remarks. (In following R_t is rise time of signal and Z_s is signal source impedance. Values are approximate.
187 Probe**		100K ohms/2 pf	4 mv/cm - 200 mv/cm	Provides maximum sensitivity and input impedance combination. Response and base line settings will vary with Z_s . Can cause ringing if probe tip and ground are too long. Ringing not bothersome with tip and ground pin supplied if source has $R_t > 1$ nsec and $Z_s > 50 \Omega$.
Probe Socket *	10210A (187B-76G)	100K ohms/2 pf	4 mv/cm - 200 mv/cm	Supports probe and insures solid connection to signal source. Also provides excellent ground return so that ringing is less likely than with ground pin.
Isolator	10213A	100K/4 pf	4 mv/cm - 200 mv/cm	Eliminates response change and baseline shift as a function of Z_s . Increases input capacity by 2 pf but has advantage that 200 ohm series resistor and very compact grounding tab limit ringing so that there is no problem for $R_t > 0.5$ nsec.
BNC Adapter **	10207A (187A-76A)	100K ohm/4 pf	4 mv/cm - 200 mv/cm	Screws into 10206A Probe and Type N Adapter (below) to provide low inductance connection to BNC fittings. Since probe impedance is high compared to 50Ω BNC system it will make an essentially open-circuit measurement across Z_s . $R_t > 0.5$ nsec will not exhibit ringing.
Probe and Type N Adapter **	10206A (187B-76F)	100K ohm/4.5 pf	4 mv/cm - 200 mv/cm	Accepts 10207A BNC adapter (above) and also screws directly onto Type N female fittings. Since probe impedance is high compared to 50Ω Type N system it will make an essentially open-circuit measurement across Z_s . $R_t > 0.5$ nsec will not exhibit ringing.
Blocking Capacitor (.001 uf)	10208A (187A-76D)	100K ohm/2.5 pf	4 mv/cm - 200 mv/cm	Blocks up to 600V peak DC component. Increases input capacity very slightly. See Figure 7 for information on sag as a function of accessory to which it is attached. Preferred over 0.1 uf capacitor (below) when sag is no problem.
Blocking Capacitor (.1 uf)	10209A (187B-76H)	100K ohm/5.5 pf	4 mv/cm - 200 mv/cm	Blocks up to 600 V peak DC component. Construction is such that it adds 3.5 pf shunt capacity to input and therefore requires very low Z_s to preserve high R_t . Recommended for use only where sag is a problem (see Figure 7).
10:1 Divider	10202B (187B-76C)	1 meg/2.5 pf	40 mv/cm - 2 v/cm	Increases input resistance to 1 megohm with negligible increase in shunt capacity. Isolates Z_s from probe so baseline shift and response change are eliminated. Has some probe tips and ground pin considerations with regard to ringing as bare probe (see Table II).
100:1 Divider	10203A (187B-76J)	10 meg/1 pf	400 mv/cm - 20 v/cm	Increases input resistance to 10 megohms with reduction of input capacity to 1 pf. Isolates probing Z_s from probe so baseline shift and response change are eliminated. Has some probe tip and ground pin considerations with regard to ringing as bare probe (see Table II), but reduced input C raises ringing frequency so that overshoot is not as great as 10:1 Divider for fast rise times.

Table Ib 50 ohm Sampling Accessories for hp 185 Sampling Oscilloscope

Accessory	hp Model Number	Input Impedance/ Shunt Capacitance	Range of Oscilloscope Sensitivity with Accessory	Remarks - Waveforms in Table II demonstrate most of these remarks. (In the following R_t is risetime of signal and Z_s is signal impedance. Values are approximate
Resistive Dividers 5:1 ***	10201A (185A-21C)	250 ohms/0.4 pf	20 mv/cm - 1 v/cm	Dividers have low shunt capacity but also input resistance. Care should be taken when probing where loading can upset DC bias of system tested. Blocking capacitors may be used with these dividers. They must be terminated in either 50 ohms via the Bridging Tee (below) or by the hp 1100A Delay Line System (below). Their very low shunt capacity makes them useable regardless of signal risetime because their ringing frequency with the probe tip and ground pin supplied is well above the response of the scope.
10:1	10201B (185A-21D)	500 ohms/0.4 pf	40 mv/cm - 2 v/cm	
50:1	10201C (185A-21E)	2500 ohms/0.4 pf	200 mv/cm - 10 v/cm	
100:1	10201D (185A-21F)	500 ohms/0.4 pf	400 mv/cm 20 v/cm	
50-ohm Bridging Tee	10204B (187B-76E)	50 ohm line section	Same as probe or accessory used	Permits bridging measurements in 50 ohm systems with negligible effect on signal source or load. Type N adaptors are available for all other standard 50 ohm coaxial fitting systems. No appreciable ringing within response of scope. Probe in Tee causes reflection from a step input that is a negative spike less than 25% of the step amplitude and not longer than 0.5 nsec.
50-ohm Termination	908A	50 ohms		Load has Type N fitting and reflection less than 2-1/2% to frequencies well above the scope response. Max power dissipation is -/2 watt.
50 ohm * Delay Line System	1100A (Includes 10205A, 10121A, 10212A)	50 ohms	8 mv/cm - 400 mv/cm	Delay line response is such that a risetime of 0.5 nsec is not deteriorated by more than 10% and overshoot not increased by more than 2%. Sync Take off splits signal and provides half voltage to 50 ohm sync input and other half to 50 ohm, 120 nsec delay line. Delay line load is compensated and built to accept probe in same manner as the bridging Tee. Remember to multiply scope sensitivity by two.
<p>* Accessory not supplied with Model 1102A Accessory Kit ** 2 Supplied with Model 187B Dual Trace Sampling Plug-In *** These numbers will be doubled if dividers are used with the hp 1100A Delay Line System</p>				