

High Productivity Measurements in Digital Transmission

Application Note 387

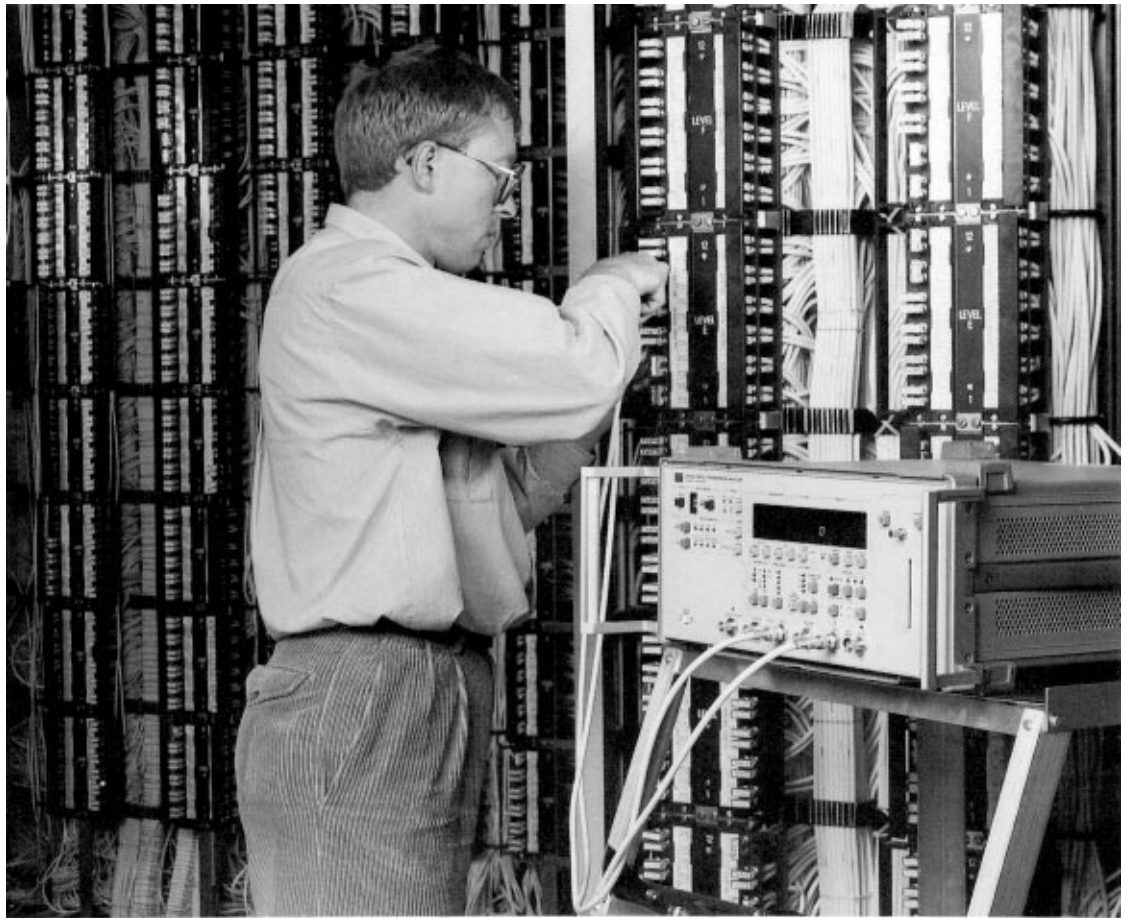

Contents

	Page
Introduction	3- 7
Interface specifications and standards (G.703, G.823)	8-12
Transmission performance and standards (G.821, G.921, M.550, Rec.594)	13-26
Summary of digital transmission standards	27
Jitter testing	29-34
Error performance testing and how to use the standards	35-39
HP error performance analyzers	40-43

*This application note was first presented in May 1989
as a paper at HP's UK Telecom/Datacom Measurement
Symposium in London by Hugh Walker, Marcom
Manager, Queensferry Telecom Division.*

High productivity measurements in digital transmission

- Overview of digital transmission testing**
- Interface standards and jitter**
- Error performance standards**
- Jitter tests**
- Error performance**
- HP error performance analyzers**

In this paper I would like to discuss the CCITT standards relating to the test of digital transmission systems, particularly the latest of 1988 error performance standards, contained in the CCITT Blue Books.

A telecommunications network

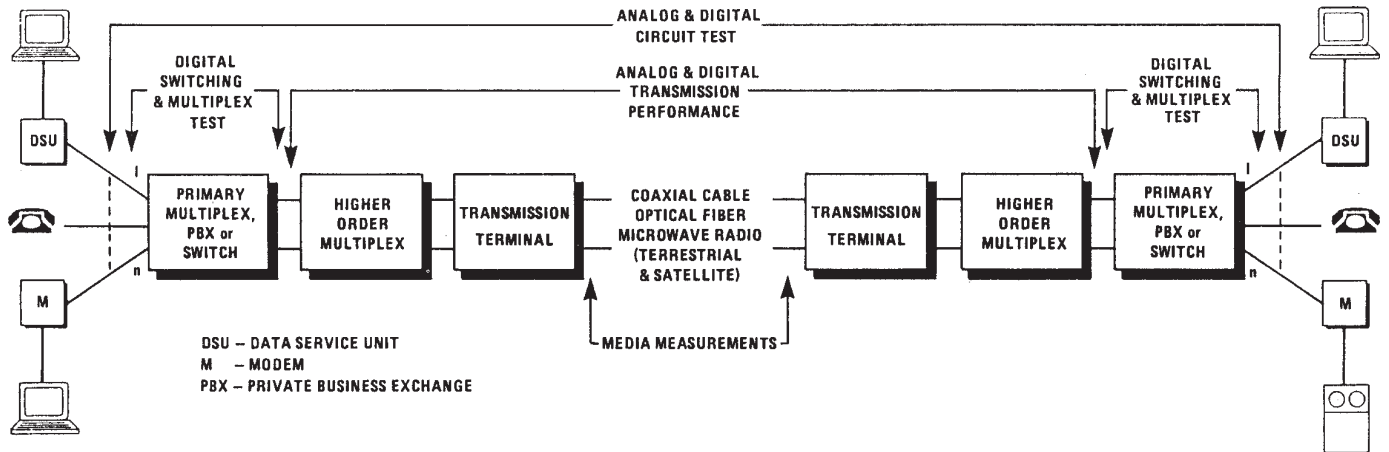

Here's a very simplified block diagram of a telecommunications connection between one end user and another, showing the various blocks or network sections the signal passes through.

We've defined the digital transmission section to include the higher order multiplex equipment which takes the 2 Mb/s primary rate tributaries to the higher transmission rates such as 139 Mb/s, and the transmission system itself which typically uses lightwave or microwave transmission.

Digital transmission systems

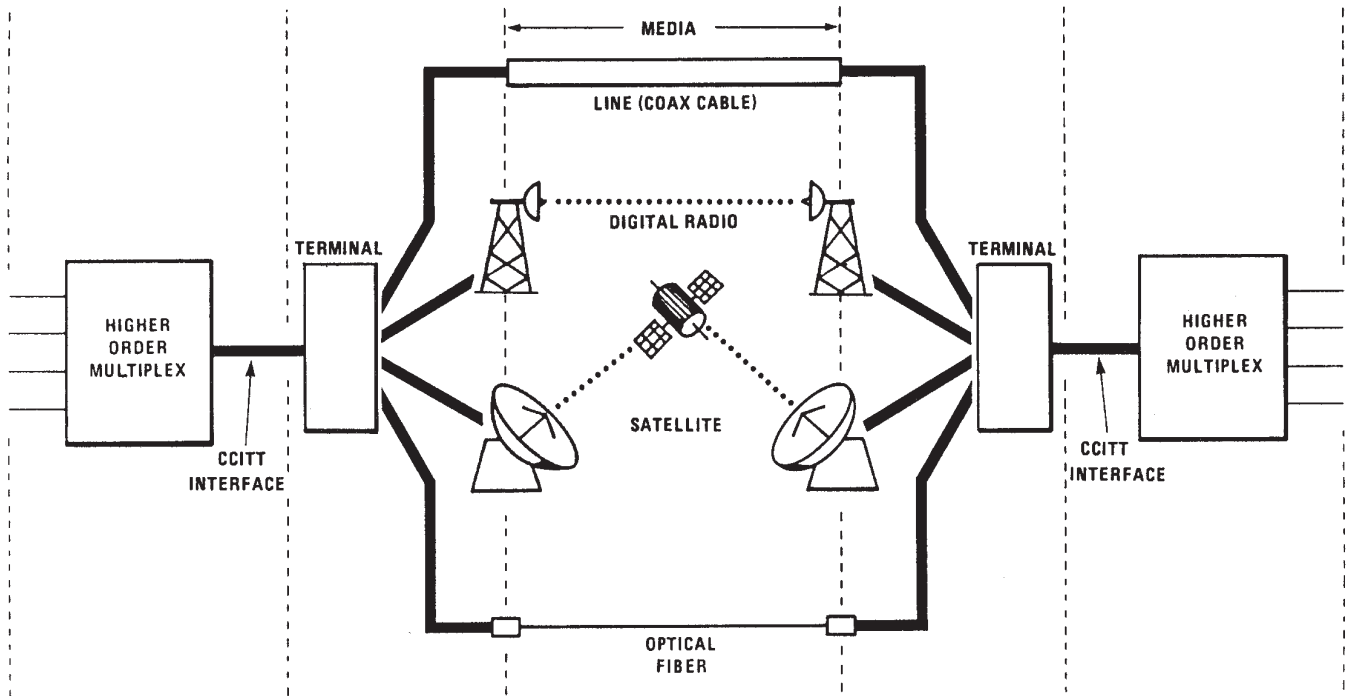

Expanding the digital transmission section of the network, I'd like to define the measurements I will talk about in this paper. We will look at measurements via the standardized digital interfaces available on multiplex and transmission terminals, but will not consider measurements made on the actual transmission medium itself or within the transmission terminal.

European digital multiplex hierarchy

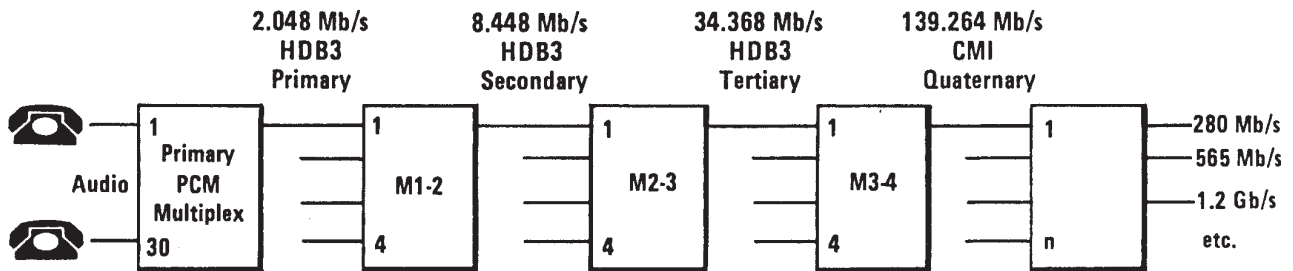

Just to recap on the standard European digital multiplex hierarchy, the primary multiplex frame is a synchronous interleaving of 30 x 64 kb/s traffic channels that could contain data or PCM telephony. That gives us the primary rate data stream of 2.048 Mb/s, which is the basic building block for the higher-order multiplexing.

At each stage of multiplexing up to 139 Mb/s, the bit rate, interface code, signal level and framing are standardized. 139 Mb/s represents 1920 multiplexed 64 kb/s channels and is commonly used in high-capacity transmission systems in PTTs, with a gradual move to 565 Mb/s and 2.4 Gb/s. 34 Mb/s and below is popular for lower-capacity routes and private networks.

Specifications for digital transmission systems

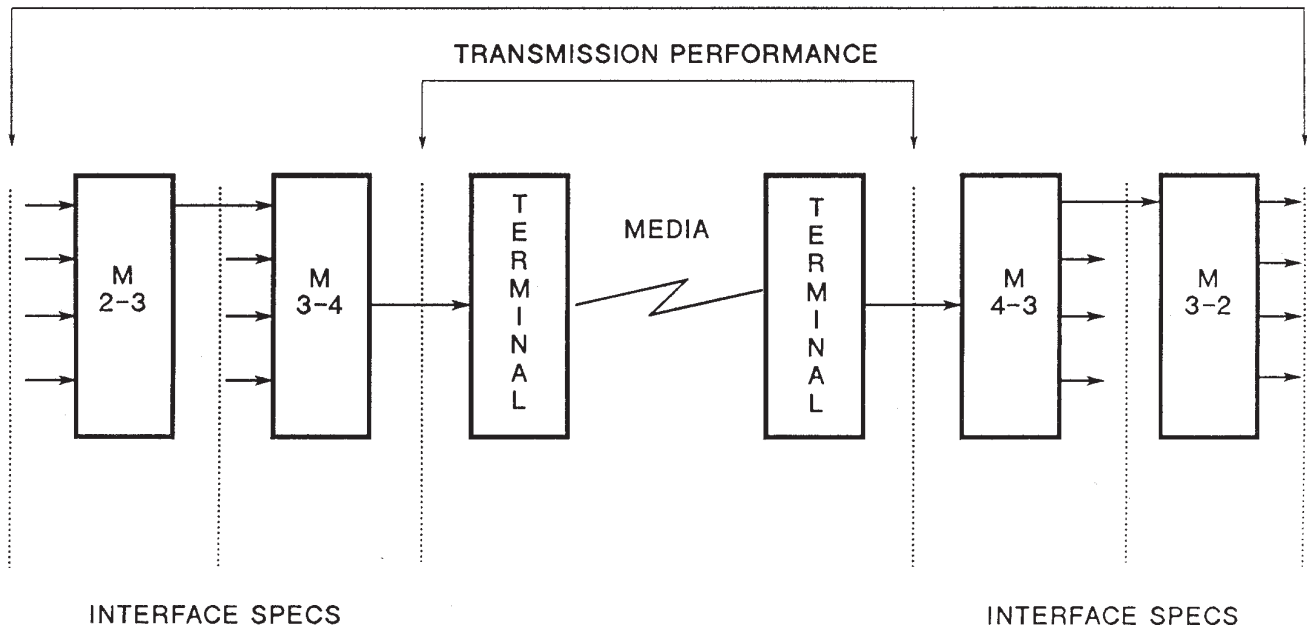

Specifications and testing of digital transmission equipment and systems can be divided into two classes.

Firstly, there is a group of standards which define the electrical interfaces between equipment. Conformance to these specifications allows pieces of equipment and test sets from different manufacturers to work together successfully. Typically, interface specs are checked at the manufacturing stage only, but sometimes it is necessary to re-check them in a maintenance/installation environment if degraded performance is experienced.

Secondly, a transmission system must be specified for its overall error performance, measured over a period of time. Conformance to these specs ensures that an installed system will meet the requirement of an Integrated Digital Network.

Transmission performance measurements are the principal tests made in the maintenance environment. The current CCITT standards relate to out-of-service tests and these are the ones I will discuss in this paper.

Let's take a look at each of these categories in a little more detail, and review the appropriate standards.

Interface specifications

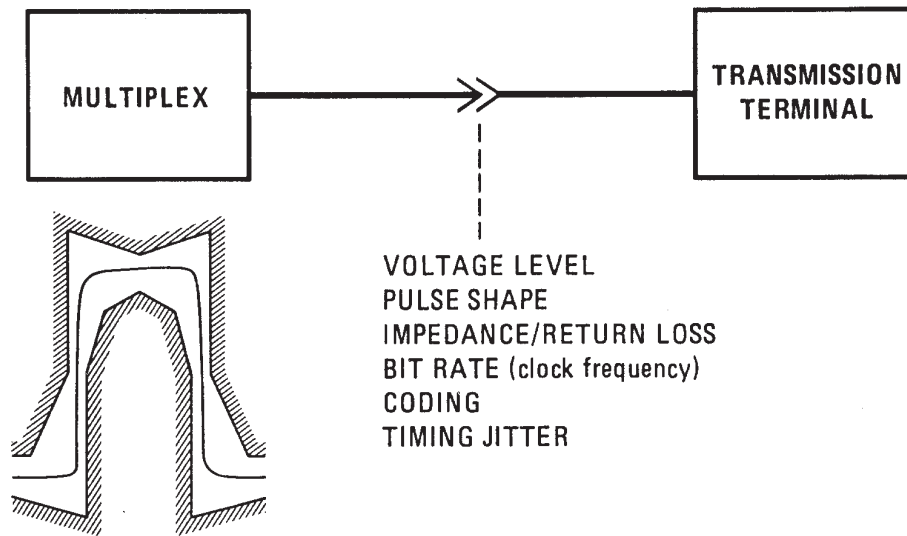

Those of you who have worked in RF and microwave will know the importance of “matching” at interfaces so that the performance of cascaded networks will equal the sum of the parts.

The same is true in digital communications equipment and instruments - if they are not “matched”, bit errors will appear when they are connected together. This matching is defined in a series of interface specifications contained in CCITT Rec. G.703.

The specifications include pulse height, pulse shape (i.e. rise-time, fall-time, overshoot, duty cycle) and equality of positive and negative pulses in a ternary signal. These are oscilloscope measurements and it's necessary to check that the pulse shape falls within the prescribed mask (a typical mask is shown above). Pulse measurements can be conveniently made using a digitizing oscilloscope such as the HP54501A (100 MHz) or HP54110D (1 GHz).

The physical interface is usually 75 ohm coaxial with a return loss of 15-20dB. Bit rates must be maintained within strict limits (as shown on the next page), and it's necessary to check that receiving equipment can operate correctly within this tolerance. Interface code specifications include algorithms for AMI, HDB3, CMI, B3ZS and so on.

Clock tolerance (G.703)

2.048 Mb/s	+/-	50 ppm
8.448 M/bs	+/-	30 ppm
34.368 Mb/s	+/-	20 ppm
139.264 Mb/s	+/-	15 ppm

This table shows the tolerance on clock rate or bit rate at the equipment interface according to CCITT Rec. G.703. The standard interface codes such as HDB3 and CMI ensure sufficient data transitions for reliable clock recovery with any arbitrary data stream. The clock recovery circuit is usually a tuned circuit or phase-locked loop which has a limited bandwidth of operation. As a minimum requirement it must provide reliable clock recovery over the CCITT tolerance range. Typically, this is tested by varying the clock-rate and checking if any transmission errors occur.

Perhaps the most important interface specification, which also relates to the clock recovery circuits, is timing jitter.

Timing jitter

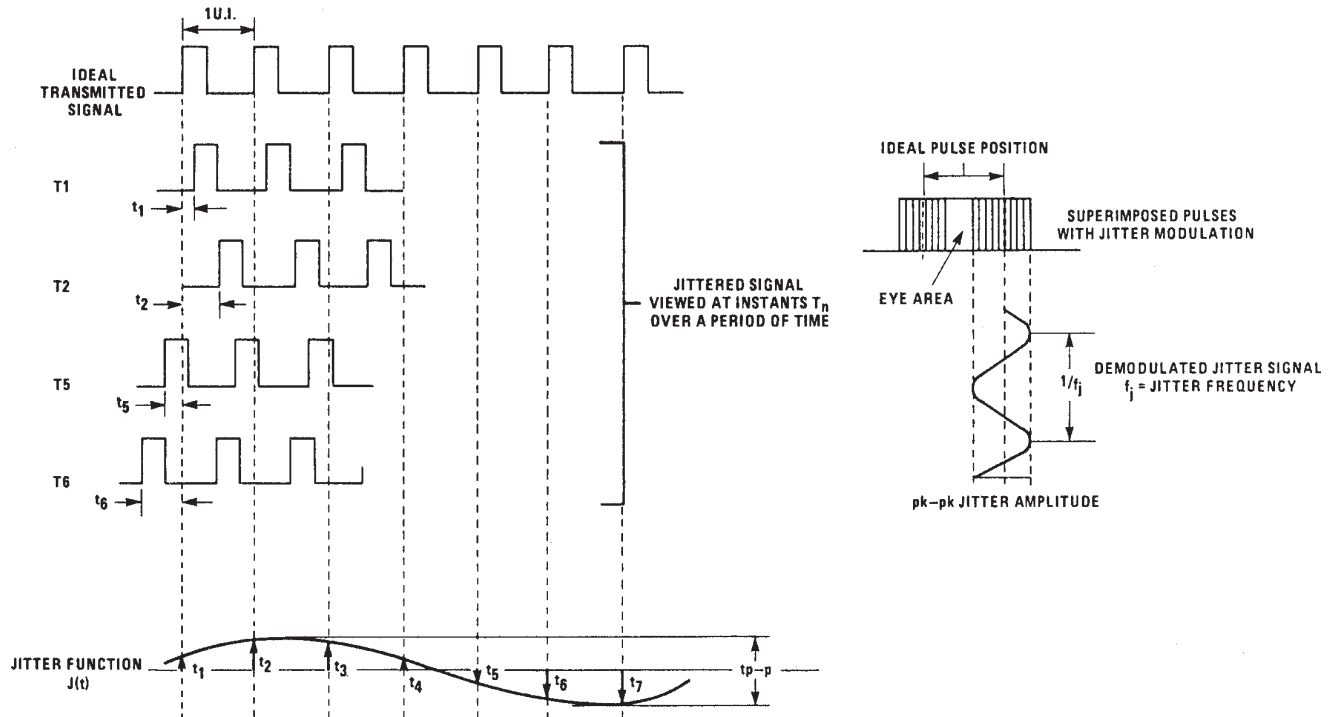

One of the best definitions of timing jitter has been provided by CCITT. Timing jitter is “short term variations of the significant instants of a digital signal from their ideal positions in time”. The significant instant might be the rising or falling edge of a pulse. You can see the effect of jitter in the diagram above. At certain points in time the pulse is significantly offset from its correct position. If this offset becomes large, then there will be an error when we try to sample and decode the digital signal. The disturbance or offset of the timing instant is usually measured in Unit Intervals peak-to-peak (UI), equivalent to one bit period.

One of the advantages of recovering a timing clock from the data stream is that it will tend to track any timing jitter present in the data. Provided this tracking occurs, then no errors will result when the recovered clock is used to sample the data. In view of the limited bandwidth of clock recovery circuits, this advantage only exists at low jitter modulation frequencies, at higher jitter frequencies the tracking diminishes and the equipment’s tolerance to input jitter is greatly reduced.

For this reason, jitter standards are always specified in terms of UI versus jitter frequency for various bit rates.

Note:

We don't have space in this paper to discuss the sources of jitter in digital networks, however, this is covered in another Hewlett-Packard publication: “Jitter Measurements in the Integrated Digital Network” by Ron McDowall (publication no. 5954-7939).

Jitter tolerance standard (G.823)

Parameter values for input jitter and wander tolerance

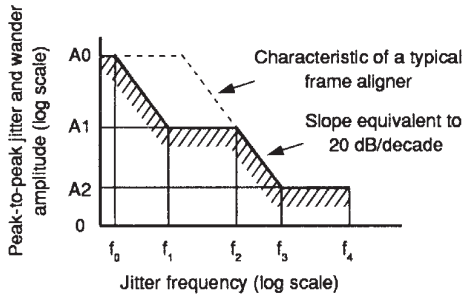

Lower limit of maximum tolerable input jitter and wander

Parameter value Digit rate kbit/s	Peak-to-peak amplitude unit interval			Frequency					Pseudo-random test signal
	A ₀	A ₁	A ₂	f ₀	f ₁	f ₂	f ₃	f ₄	
64 (Note 1)	1.15 (18 μs)	0.25	0.05	1.2	20 Hz	600 Hz	3 kHz	20 kHz	2 ⁿ - 1 (Rec. O.152)
2048	36.9 (18 μs)	1.5	0.2	×10 ⁻⁵ Hz	20 Hz	2.4 kHz (93 Hz)	18 kHz (700 Hz)	100 kHz	2 ⁿ - 1 (Rec. O.151)
8448	152 (18 μs)	1.5	0.2	1.2 ×10 ⁻⁵ Hz	20 Hz	400 Hz (10.7 kHz)	3 kHz (80 kHz)	400 kHz	2 ⁿ - 1 (Rec. O.151)
34 368	*	1.5	0.15	*	100 Hz	1 kHz	10 kHz	800 kHz	2 ⁿ - 1 (Rec. O.151)
139 264	*	1.5	0.075	*	200 Hz	500 Hz	10 kHz	3500 kHz	2 ⁿ - 1 (Rec. O.151)

For example here is the input jitter tolerance specification from CCITT Rec. G.823 showing the high tolerance at low jitter frequencies which decreases at high jitter frequencies. Jitter tolerance is tested by checking that no bit errors occur at the output of an equipment when its input is stressed with the maximum permitted jitter level. A little later I'll show how this measurement can be made automatically.

Three jitter specifications

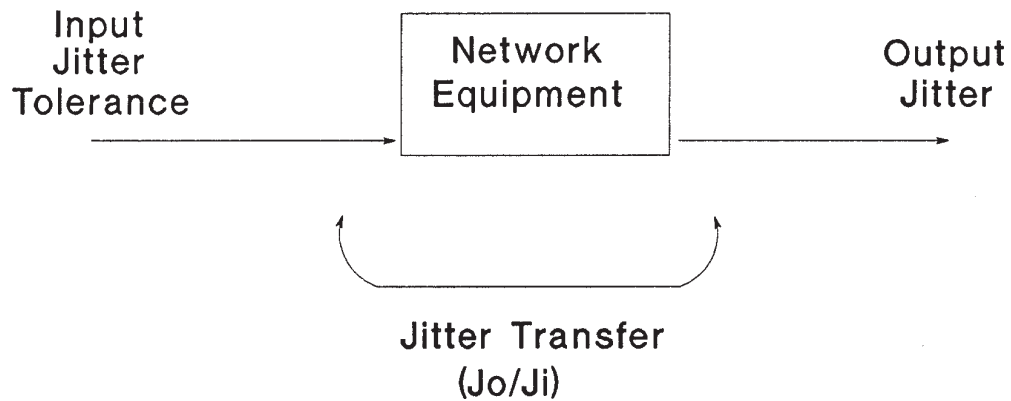

In the previous figure we discussed the definition of input jitter tolerance. To fully specify the jitter performance of a piece of equipment, we need to measure the jitter level at the output and also the jitter transfer function or the degree to which jitter present at the input is amplified or attenuated by the equipment. The permitted levels for these parameters are all specified in G.823 and the measuring methods and receiver bandwidths defined in CCITT Rec. O.171.

When an equipment meets the G.823 specifications at the hierarchical interfaces, we should be able to interconnect network sections without causing bit errors.

Usually these tests are made in production but it may be necessary to recheck them in the field if trouble is experienced.

Measuring transmission performance

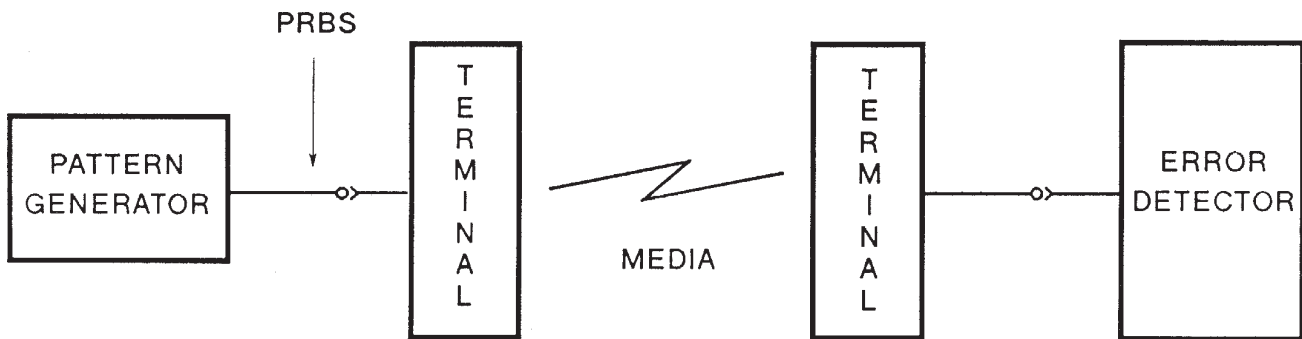

Having discussed interface specifications, let's look at determining the quality of transmission performance. In digital systems this is determined by the rate of errors in the received data stream.

Error performance can be estimated from in-service performance monitors built into the transmission equipment, or directly by simulating traffic with a pseudo random binary sequence (p.r.b.s.) and checking the received data bit-by-bit for errors. From that we can calculate the Bit Error Ratio (BER). This is called an out-of-service test and is the method envisaged in the CCITT error performance standards.

The p.r.b.s. test signal is standardized in CCITT Rec. O.151, so test equipment from different manufacturers can work together and give consistent measurement results. The next figure shows the typical construction of a BER tester.

What's in a BER tester?

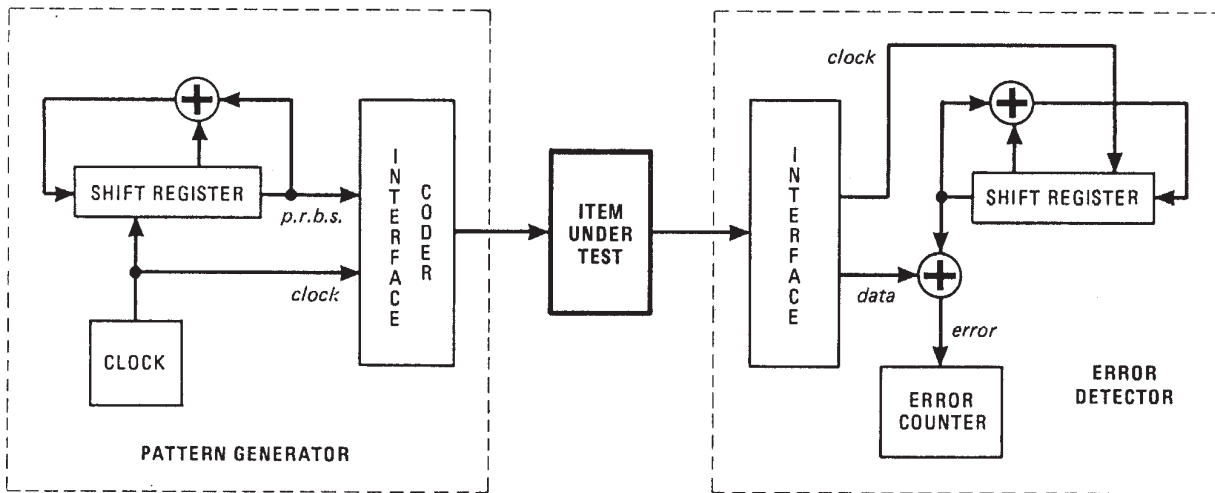

A BER tester consists of a pattern generator and error detector, often combined in a single instrument though sometimes separate. The p.r.b.s. is generated using a feedback shift register which is driven by a very stable clock source - either internal or derived externally from a synthesiser. The raw data from the shift register is usually passed through an interface circuit to generate the correct code format and output level (G.703).

At the receive side the same type of interface circuit strips off the code and recovers a clock. This clock drives a reference p.r.b.s. generator whose output is compared with the received data. When the system has synchronized correctly, every error in the received signal will be recorded in the error counter. The error detector can then compute the BER and also analyze the results statistically to determine how BER varies as a function of time.

Note:

The specification for a BER tester is now highly standardized (CCITT Rec. 0.151). A standard p.r.b.s. of $2^{15}-1$ is used for lower speed transmission systems, and $2^{23}-1$ for higher speed systems. Because of this standardization, it is normally possible to inter-work pattern generators and error detectors from different manufacturers.

Error performance

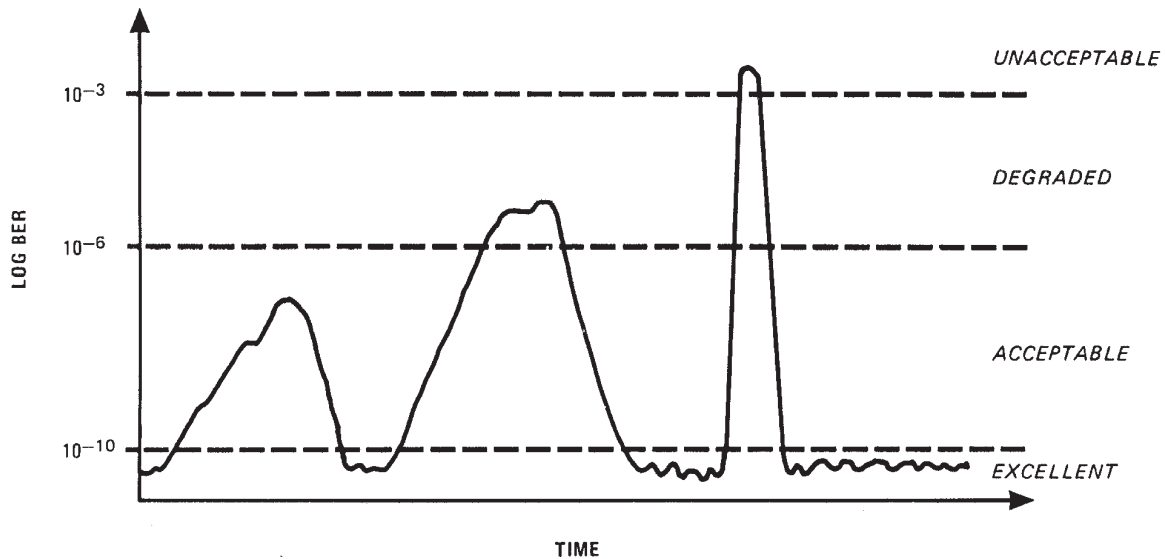

The BER on most digital systems varies due to propagation effects in radio transmission or electrical interference. We need to ensure that practical systems don't exceed critical thresholds for more than a certain percentage of the time. These BER thresholds are set at 10^{-3} and 10^{-6} , and the performance is classified in CCITT recommendation G.821 and CCIR recommendation 594. We'll review these important standards in the next pages and look in more detail at how they are used when we discuss measurements later. I am working from the latest 1988 revision of CCITT recommendations known as the "Blue Books".

The percentages of time for degraded performance are very small and most of the time the system operates with very low background error rates, perhaps 10^{-12} or better. At this level a 139 Mb/s system, for example, might only produce 1 error per day.

Note:

For more information, see "Error Performance Requirements for Future ISDNs" by Ron McDowall (HP publication no. 5954-7938).

CCITT recommendation G.821

Error performance of an international digital connection forming part of an ISDN.

PERFORMANCE CLASSIFICATION	OBJECTIVES
DEGRADED MINUTES (DM)	Fewer than 10% of one minute intervals to have a Bit Error Ratio (BER) worse than $1E-6$
SEVERELY ERRORED SECONDS (SES)	Fewer than 0.2% of one second intervals to have a Bit Error Ratio (BER) worse than $1E-3$
ERRORED SECONDS (ES)	Fewer than 8% of one second intervals to have any errors – equivalent to 92% error free seconds

Measured over a period T_L (e.g.1 month) on a unidirectional 64 kb/s channel of the hypothetical reference connection (HRX) of 27,500 km

CCITT Recommendation G.821 refers to the overall performance for the end-to-end 64 kb/s connection on a very long (27,500 km) international connection. It's the starting point for error performance measurements, but needs to be interpreted before we can use the criteria on a practical transmission system.

Note:

The parameters shown here are measured out-of-service with a p.r.b.s. In-service measurement results acquired through CRC, FAS† checks etc. are sometimes referred to as pseudo severely errored seconds and pseudo degraded minutes (see Rec. M550).*

* CRC – Cyclic Redundancy Checksum

† FAS – Frame Alignment Signal

G.821 classification

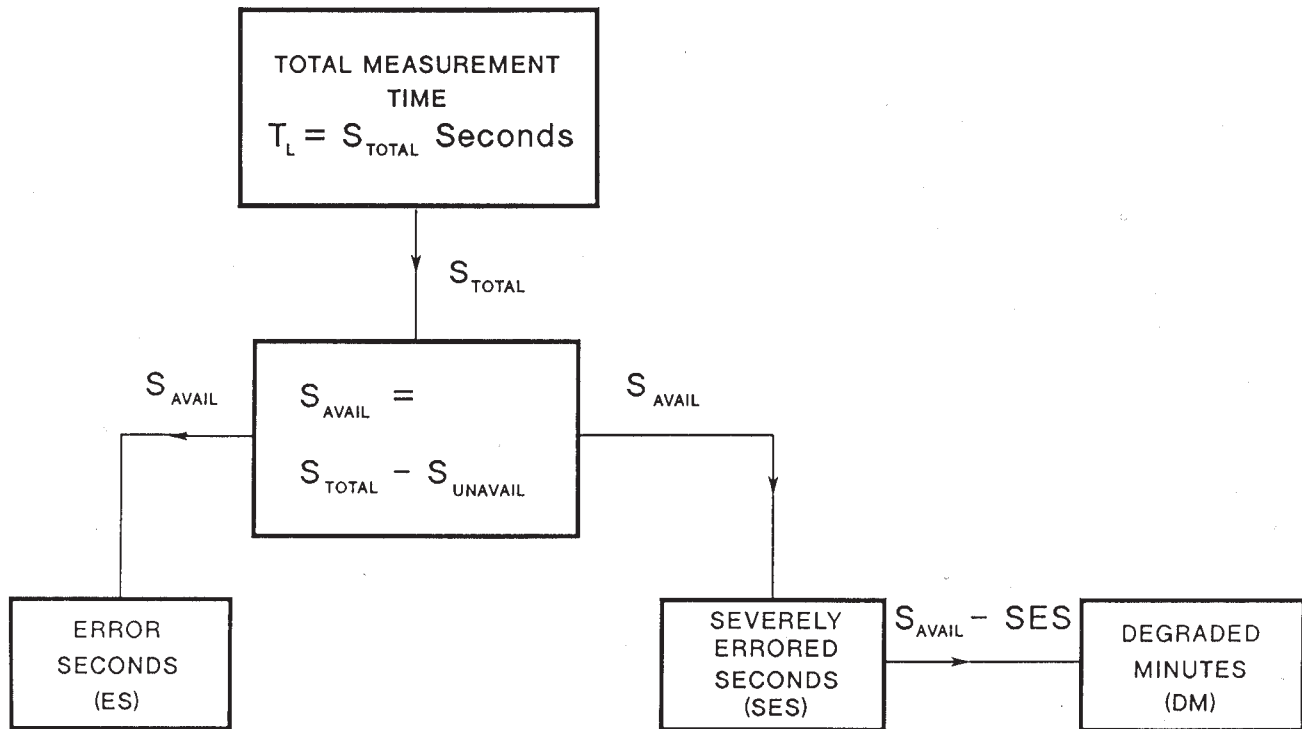

Recommendation G.821 defines how the error performance parameters are calculated. The total measurement time is divided into 1 second periods, and unavailable time* is subtracted to obtain the available time on which the G.821 parameters are calculated.

During available time, any second containing 1 or more errors is logged as an errored second (ES). Any period of 1 second with a BER exceeding 10^{-3} is classified as a severely-errored second (SES). These are subtracted from available time and the remainder grouped into 60 second periods. Any of these 1 minute periods with a BER exceeding 10^{-6} is classified as a degraded minute.

This classification and calculation is carried out automatically in Hewlett-Packard digital transmission analyzers.

* A period of unavailable time begins when the BER in each second is worse than 10^{-3} for a period of ten consecutive seconds. These ten seconds are then considered to be unavailable time. A new period of available time begins with the first second of a period of ten consecutive seconds each of which has a BER better than 10^{-3} .

Hypothetical reference connection

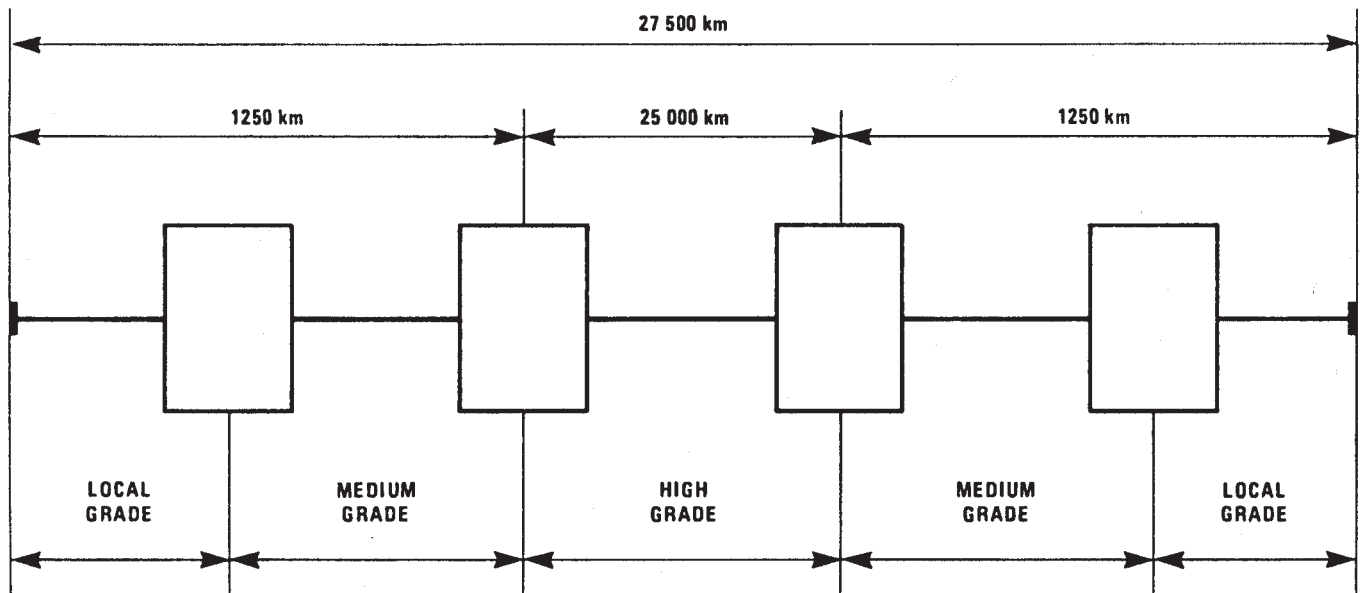

The Hypothetical Reference Connection (HRX) defined for G.821 is shown above. As you can see, the connection consists of a local and medium-grade section at each end of the link, and a long distance high-grade section in the middle.

Very few connections are this long! Most systems, however, will have the same network sections in an end-to-end connection, and typically a high capacity transmission system such as microwave or lightwave would be characterized as a high-grade section.

Typically the low-grade section would be the metallic subscriber loop, and medium grade would be the connection from, say, a local exchange to a trunk switching centre.

The three types of section in the network are allocated different portions of the total G.821 specification.

Allocation of degraded minutes and errored seconds objectives

CIRCUIT CLASSIFICATION	ALLOCATION OF DEGRADED MINUTES AND ERRORED SECONDS OBJECTIVES
LOCAL GRADE (two ends)	15% block allowance to each end
MEDIUM GRADE (two ends)	15% block allowance to each end
HIGH GRADE	40% (equivalent to conceptual quality of 0.00016% DM/km. 25,000 km)

Allocation of severely errored seconds

CIRCUIT CLASSIFICATION	HRDS length (km)	ALLOCATION OF SEVERELY ERRORED SECONDS OBJECTIVES	To be used in circuit classification
LOCAL GRADE (two ends)	280	0.015% block allowance to each end 0.45%	High grade
MEDIUM GRADE (two ends)	280	0.015% block allowance to each end 2%	Medium grade
3 HIGH GRADE	50	2%	Medium grade
4	50	0.04% or 0.004% per 2500 km 5%	Medium grade

As the tables show, the allocation of Degraded Minutes (DM) and Errored Seconds (ES) is handled slightly differently from Severely Errored Seconds (SES). Low and medium grade sections are allocated a block allowance of 15% of the total G.821 specification at each end for DM and ES (i.e. 1.5% DM and 1.2% ES) irrespective of length. The longer high-grade section is apportioned on a distance basis so that the 40% allowance is reduced in the ratio L/25,000.

Thus for a high-grade section of length L km:

$$\text{Allowable DM} = 10\% \times 0.4 \times L/25000 = 0.00016\%/km$$

$$\text{Allowable ES} = 8\% \times 0.4 \times L/25000 = 0.000128\%/km$$

Severely Errored Seconds are allocated on a block basis only. 0.1% (of the total 0.2% G.821 specification) is allocated on a block basis as shown in this table. The remaining 0.1% SES is allocated to the medium and high-grade sections to account for adverse operating conditions such as propagation in microwave radio systems. For example, G.821 recommends that an additional 0.05% SES may be allocated to a medium or high-grade microwave radio section of 2500 km.

CCITT recommendation G.921 hypothetical reference digital section

Digital section quality classifications for error performance

Section quality classification	HRDS length (km)	Allocation	To be used in circuit classification
1	280	0.45%	High grade
2	280	2%	Medium grade
3	50	2%	Medium grade
4	50	5%	Medium grade

Recommendation G.821 is the fundamental error-performance specification, but needs to be interpreted for checking a practical transmission system.

CCITT Recommendation G.921 defines the performance of a Hypothetical Reference Digital Section (HRDS) and is based on the requirements of G.821 and G.823 (jitter specs discussed earlier).

For error-performance, G.921 considers digital sections of 280 km (or multiples of 280 km) and assigns a percentage allocation of the overall G.821 specification. Shorter medium grade connections are also defined as shown in this slide.

Note that these allowances are not intended to be reduced for routes less than the length shown, however, shorter systems could be designed with greater per-km BER and still meet the objective.

CCITT recommendation M.550

Example bringing into service limits for 64 kbit/s digital paths and sections

Alloc. %	Ref. Perf. Obj. Events/3 days			S1 Limit Events/3 days			S2 Limit Events/3 days		
	ES	SES	DM	ES	SES	DM	ES	SES	DM
<= 1	207	2.6	4.3	104	1	2	-	-	-
<= 2	415	5.2	8.6	207	3	4	-	-	-
<= 3	622	7.8	13	311	4	6	For	further	study
<= 4	829	10	17	415	5	9	-	-	-
<= 5	1037	13	22	518	6	11	-	-	-
<= 6	1244	16	26	622	8	13	-	-	-

Example maintenance limits for 64 kbit/s digital sections

Alloc. %	Ref. Perf. Obj. Events/24 hrs			Unacceptable Limit Events/15 min			Degraded Limit Events/24 hrs		
	ES	SES	DM	ES	SES	DM	ES	SES	DM
<= 1	69	0.9	1.4	100	12	15	77	2	2
<= 2	138	1.7	2.9	100	12	15	130	3	4
<= 3	207	2.6	4.3	100	12	15	190	4	6
<= 4	276	3.5	5.8	100	12	15	250	5	8
<= 5	346	4.3	7.2	100	12	15	306	6	10
<= 6	415	5.2	8.6	100	12	15	360	7	12

A new recommendation in the 1988 Blue Book is M.550 "Performance Limits for Bringing Into Service and Maintenance of Digital Paths, Sections and Line Sections". This recommendation reiterates the contents of G.821 and G.921.

Again, it attempts to give a practical interpretation of the original G.821 recommendation, noting that the measurement period of 1 month suggested in G.821 is impractical in many cases.

The tables show examples of how this recommendation is written. You can see that the recommended period for measurement is quite short, and that the G.821/G.921 specs have been interpreted in terms of total number of events (ES,SES,DM) which are allowed in that test period.

To use these tables you need to work out the % allocation for the digital section you are testing, either from the G.921 table given on the previous page, or by working back from the block and length allocations in G.821 (page 19).

Example relative limits

DIGITAL LINE SECTION		DIGITAL PATH & SECTION		USER
Limit	Rel. no. of impairments	Limit	Rel. no. of impairments	Performance for user
Bringing into service	01	Bringing into service	01	GOOD
Performance after repair	0.125	Performance after repair	0.125	
Degraded	0.5	Bringing into service	0.5	GOOD
Performance after repair	0.75	Performance after repair	0.75	
Reference performance objective	1	Degraded	0.75	BAD
Unacceptable	10	Reference performance objective	1	
	UNACCEPTABLE	Unacceptable	10	UNACCEPTABLE

Another useful feature of M.550 is that it suggests some performance limits for testing digital lines, paths and sections so that adequate margins are allowed for degradation during a maintenance period. Reference performance is to the G.821/G.921 criteria. Note that G.821 is considered as the limit for the customer service, and that the operator should aim for higher performance.

At this stage, M.550 is still largely under study and can only be used as a guide, always referring back to G.821/G.921.

Propagation problems require statistical error analysis

CCIR RECOMMENDATION 594 FOR 2500 KM LINK (64 kb/s UNIDIRECTIONAL CHANNEL)

- **BER WORSE THAN 1×10^{-6} FOR LESS THAN 0.4% OF ANY MONTH.**
- **BER WORSE THAN 1×10^{-3} FOR LESS THAN 0.054% OF ANY MONTH.**
- **ERRORED SECONDS SHOULD NOT EXCEED 0.32% OF ANY MONTH.**
- **RESIDUAL BER SHOULD NOT EXCEED 5×10^{-9}
(15 MINUTE INTEGRATION).**

If you are working with digital microwave radio, you will probably be using the CCIR recommendations, notably Rec. 594-1 in the latest 1986 CCIR specifications.

Rec.594-1 is compatible with the high-grade portion of G.821 and is specified for a 2500 km path at 64 kb/s, as shown above. You will notice that an additional block allowance of 0.05% SES has been added for adverse propagation conditions (see page 19), and that an additional specification for residual or background BER has been added.

Both the residual BER (RBER) threshold and % for G.821 parameters should be reduced in proportion for systems less than 2500 km long. Considerations for measurements to Rec. 594 are given in Report 930-1 and Recommendation 634 which parallels G.921. Reports 1052 and 1053 are also useful for applications with medium or low grade links. For satellite links, CCIR Recommendation 614 should be used; this allows a 20% allocation of G.821 parameters.

As these recommendations are compatible with G.821 you can use the same measuring instruments and calculations to assess performance. The main consideration is that radio propagation is affected by weather and so measured results could be misleading unless measured over a reasonable period (e.g. 1 month).

The only unique measurement is RBER. I'll show you a simple graphical method of checking this towards the end of my paper.

Guidelines for conversion of measurements at line rate to 64kb/s criteria

- % DM Convert Directly
- % SES Convert Directly with the addition of % time with loss of frame alignment

As you may have noticed, the error performance standards we've discussed all refer to measurements at 64 kb/s, whereas practical measurements on transmission systems are invariably done at a higher multiplex rate. How do we qualify the results from a conventional BER test against the G.821 criteria? The new 1988 recommendation G.821 (Annex D) gives provisional guidelines.

Y%DM measured at the line rate can be compared directly to Y%DM at 64 kb/s.

Y%SES measured at the line rate can be converted directly to Y%SES at 64 kb/s, but if during the test a loss of frame alignment is detected (or a slip), this time as a percentage should be added. For tests conducted with an unframed p.r.b.s. (the usual situation), I assume that any temporary loss of frame would cause an error rate exceeding 10^{-3} in the error detector and therefore would be included in the above measurement.

So you can take the %DM and %SES from your HP BER tester and compare directly with the allocated G.821 spec.

Error second estimation

$$ES_{64 \text{ kb/s}} = \frac{1}{j} \sum_{i=1}^{i=j} \frac{n}{N} \times 100\% \quad \text{for } n < N$$

(for $n \geq N$, $n/N = 1$)

n = number of errors in ith second

N = higher bit rate divided by 64 kb/s

j = total number of seconds

Unfortunately the conversion for Errored Seconds is more complicated. Since the higher multiplexed bit rate contains many 64 kb/s channels, we need to know how many errors are contained in each errored second at the higher rate in order to estimate how many 64 kb/s channels have been errored, or conversely, the probability of any channel being errored.

Assuming errors are distributed evenly within the frame (the worst case condition), then the above equation is exact. If you record just a few errored seconds in the measurement period you could use this equation. On the other hand if you record a fair number of error seconds all with a fairly low and steady number of errors, you could estimate an average value for "n" and compute an average probability (n/N). Multiplying %ES value from the test set by the probability (n/N) you will have an estimated %ES at 64 kb/s.

CCITT recommendation G.822

Controlled slip performance on a 64 kbit/s international connection or bearer channel

Performance category	Mean slip rate	Proportion of time (Note 1)
(a) (Note 2)	≤ 5 slips in 24 hours	$> 98.9\%$
(b)	> 5 slips in 24 hours and ≤ 30 slips in 1 hour	$< 1.0\%$
(c)	> 30 slips in 1 hour	$< 0.1\%$

Finally, one more specification you should be aware of is recommendation G.822 for controlled slips - typically the loss or repetition of an octet (8 bits) of data. These usually occur due to synchronising clock difference in the network.

Slips essentially cause a temporary loss of frame alignment and generate a burst of errors, so contributing to degraded error performance. The G.822 recommendation is for a 27,500 HRX, and so not very relevant to a small network, however, detecting slips can be useful for troubleshooting problem networks.

Summary of transmission standards

PARAMETER	STANDARDS		
Transmission Performance	G.821 CCIR Rec. 594-1 CCIR Rec. 634 CCIR Rec. 614 G.822 (O.151)	G 9 2 1	M 5 5 0
Interface Specifications	G.703 G.823 (O.171)		

Well, I hope I've been able to explain some of the aspects of error performance standards. This slide shows the various CCITT and CCIR standards which apply to the specification and measurement of transmission systems.

- CCITT G.821 Error Performance of an International Digital Connection forming part of an ISDN.
- CCITT G.921 Digital Sections Based on the 2048 kb/s Hierarchy
- CCITT M.550 Performance Limits for bringing into service and maintenance of Digital paths , Sections and Line Sections.
- CCIR Rec. 594 Allowable BER at the output of the HRDP for Radio Relay Systems.
- CCIR Rec. 634 Error Performance Objectives for Real Digital Radio Links.
- CCIR Rec. 614 Error Performance for an HRDP in Fixed Satellite Systems below 15GHz.
- CCITT G.822 Controlled Slip Rate Objectives of an International Digital Connection.
- CCITT O.151 Specification for Pattern Generators and Error Detectors.
- CCITT G.703 Physical/Electrical characteristics of Hierarchical Digital Interfaces.
- CCITT G.823 Control of Jitter and Wander within Digital Networks based on the 2048 kb/s Hierarchy.
- CCITT O.171 Specification for Jitter Measurement Apparatus.

HP 3784A digital transmission analyzer



I'd like to conclude my paper by discussing measurement techniques in conjunction with our new BER and jitter test set, the HP 3784A, shown above. As you can see, it's a portable instrument, well suited to the field maintenance environment, and with full programmability, equally at home in manufacturing test.

It's a combined transmitter and receiver operating at 704 kb/s, 2,8 and 34 Mb/s and optionally at 64 kb/s. Also available as an option the HP 3784A can make a comprehensive set of jitter tests at 2, 8 and 34 Mb/s. Furthermore, the clock source in the HP 3784A is fully synthesised from 1 kbit/s to 50 Mbit/s so you can offset the clock to check equipment clock tolerance, or to generate arbitrary bit rates. Incidentally, for measurements at 139 Mb/s we offer the HP 37721A and HP 3764A digital transmission analyzers.

We'll look first at interface tests, specifically jitter specifications.

Jitter testing

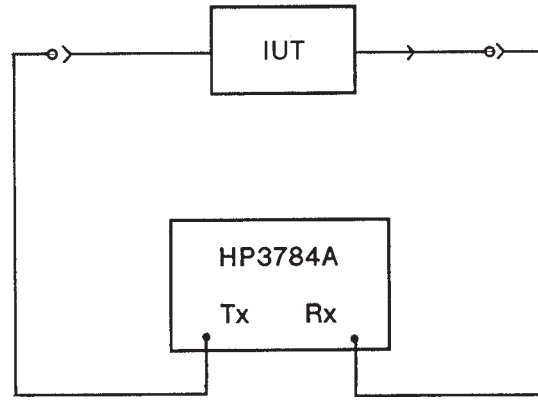

When we talked about jitter specifications a little earlier, we noted three types of measurement; jitter tolerance at the equipment input, output jitter from the equipment and jitter transfer function.

Jitter tolerance requires us to send a jittered p.r.b.s. into the item under test (IUT) and check for errors at the output. Jitter transfer function requires us to send a calibrated level of jitter into a device and measure the resulting jitter output in order to calculate the jitter, gain or loss.

The advantage of the HP 3784A is that it combines full BER and jitter capability in one package under the control of a micro-processor, so giving integrated measurements. Just connect up to the IUT and ask for jitter tests. The HP 3784A will give you automatically a plot of jitter tolerance and jitter transfer against the CCITT mask so you can see instantly the margins of your equipment. The next two figures show examples.

Jitter tolerance plot

Link : Instrument : HP3784A
Tx Location: Tx Interface: 75ohm TERM HDB3
Tx Clock : STD RATE 2MHz +0ppm
Tx Pattern : PRBS 15 ZERO SUB 000
Rx Location: Rx Interface: AS PER Tx
Rx Clock : 2MHz
Rx Pattern : AS PER Tx
Rx Hit Thres: 0.500UIP

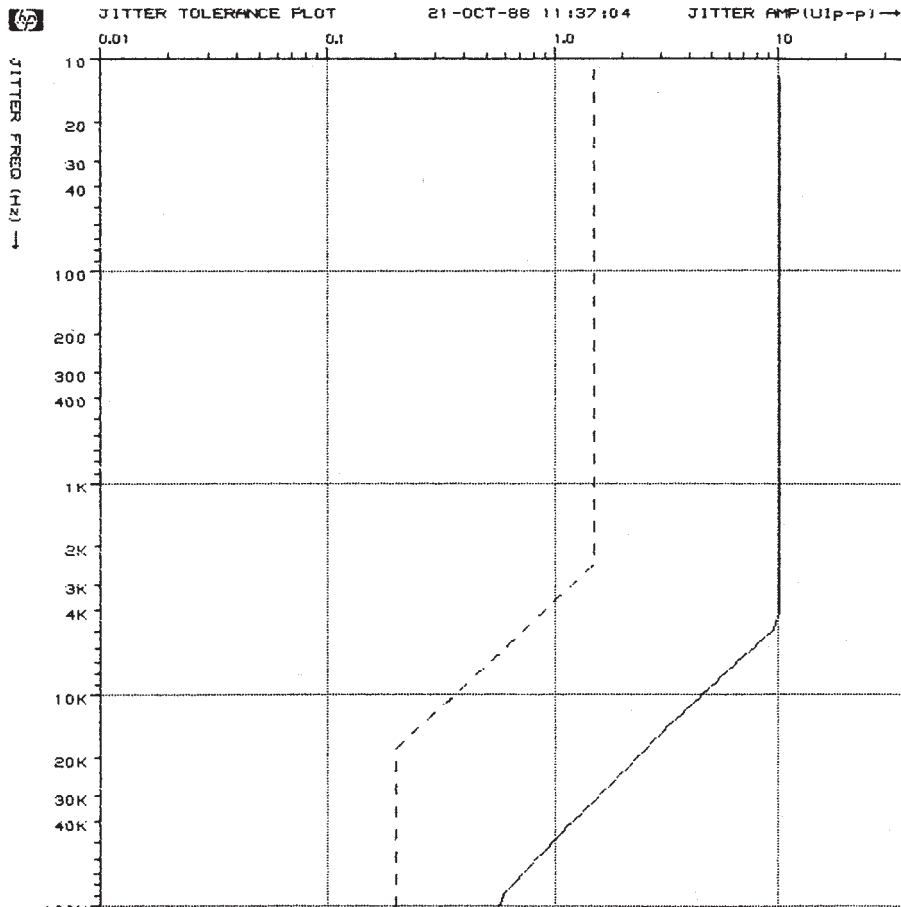

END OF JITTER TOLERANCE PLOT

Here's a jitter tolerance plot which shows measured results versus the G.823 specification (dotted line). This particular plot shows the jitter tolerance of the HP 3784A's own receiver input.

Jitter transfer function plot

Link : Instrument : HP3784A
Tx Location: Tx Interface: 75ohm TERM HDB3
Tx Clock : STD RATE 2MHz +0ppm
Tx Pattern : PRBS 15 ZERO SUB 000
Rx Location: Rx Interface: AS PER Tx
Rx Clock : 2MHz
Rx Pattern : AS PER Tx
Rx Hit Thres: 0.500UIP

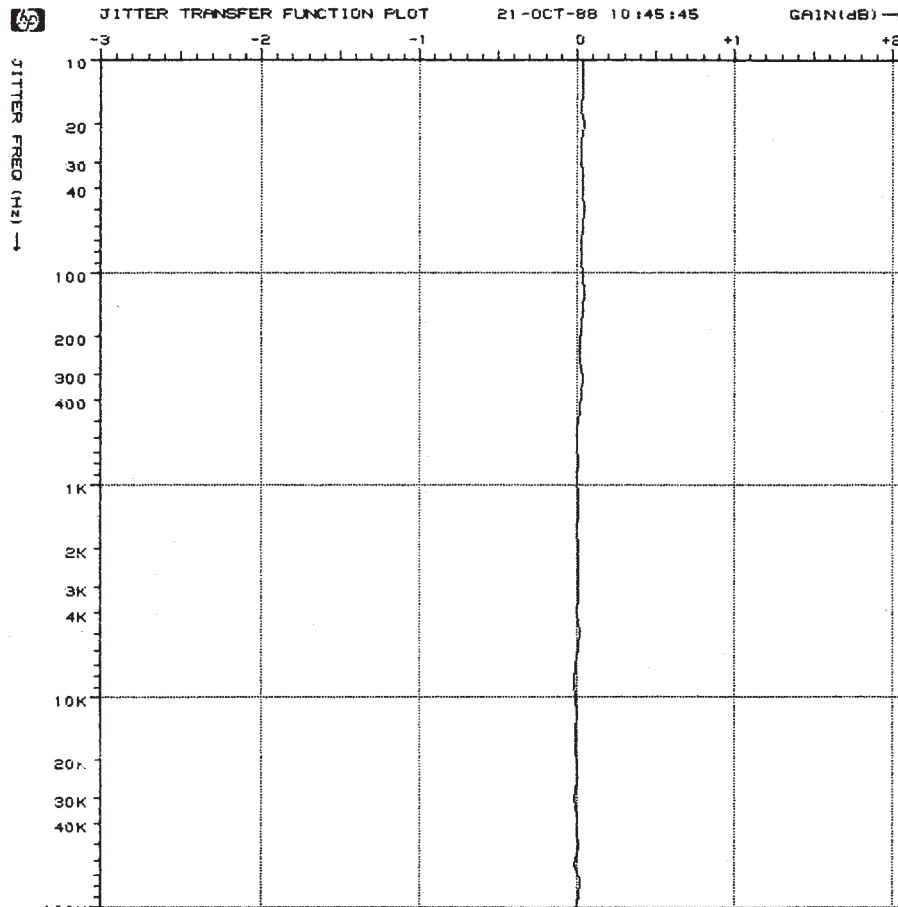

END OF JITTER TRANSFER FUNCTION PLOT

Here's an example of a jitter transfer function plot. In fact this is the back-to-back performance of the HP 3784A showing its inherent accuracy and resolution.

Measuring output jitter with the HP 3784A filters

When you measure the output jitter for an equipment, you need to take account of the jitter spectrum which will have more energy at lower frequencies. The HP 3784A contains the specified filters for 2, 8 and 34 Mb/s measurements (according to O.171) so the results you obtain can be compared directly with the limits given in G.823. This specifies for each bit-rate the maximum permissible jitter at a hierarchical interface within the given bandwidths.

When you are installing a new network you may want to check there is not excessive jitter accumulation over cascaded sections. The output jitter measurement is very easily made with the HP 3784A. In addition, you can set thresholds in the HP 3784A so that you can detect if and when the jitter level exceeds an acceptable level. Of course you can monitor jitter while a system is carrying traffic and this can help you identify the source of degraded performance. This measurement is called jitter-hits in the HP 3784A.

Testing a MUX/DEMUX

If you need to fully test a multiplexer and demultiplexer in manufacturing, it is necessary to use a framed data stream at the input to the demux rather than a p.r.b.s. The “through-data” capability on the HP 3784A and HP 3764A allows you to add a controlled amount of jitter to this framed multiplex output signal which is then applied to the demultiplexer. The setup shown in the figure provides full characterization.

Manufacturing test

Comprehensive jitter testing is usually confined to the system test area, where the programmability and built in measurement routines of the HP 3784A can make a significant contribution to productivity.

Error performance example

Finally, let's examine error performance measurements on a transmission system installed in the field - in this case a multi-hop radio route operating at 34 Mb/s over a route length of 200 km.

We are planning to measure performance using the conventional out-of-service test. How will we know if it meets the requirements of the ISDN recommendation G.821? We will assume this radio route is a high-grade section, though if you are dealing with a small network you might want to use the medium grade classification.

First we need to decide on the "apportionment" of error performance according to distance.

Apportionment

To do the distance apportionment you can use the percentages given in G.921 for a high grade or medium grade link of 280 km. (Remember that G.921 apportionment is only done in blocks of 280 km. In our case 200 km is less than the smallest block of 280 km, so we use this figure). To calculate the allowed G.821 performance allocation we take 0.45% (or 2% for medium grade) of the 10% DM, 8% ES and 0.1% SES totals. As we have a radio system we are allowed to add an extra 0.0055% SES as a block allowance.

An alternative approach is to use CCIR Rec. 594-1. In this case we take the fraction of 2500 km. to calculate the allowable percentages, the fraction being 200/2500 of the total Rec. 594-1 allowances. This also gives a guide to the maximum residual background error rate (RBER) over the 200 km. route.

You will notice that limits of performance are fairly similar, and would be virtually identical for a 280 km route length.

You might feel justified in relaxing these specifications for more economical system design if you are dealing with relatively short routes of a few hundred kms. For example, you could use the medium grade classification in G.921.

Convert 64 kb/s parameters to line rate measurements

We've calculated the performance limits for a 64 kb/s channel. What are the limits we should use for a 34 Mb/s measurement?

According to Annex D of G.821 referred to earlier, the DM% limit is directly transferable to the 34 Mb/s measurement. The SES% limit is directly transferable to 34 Mb/s except that we should add any non-severely errored seconds that cause a loss of frame alignment in a subsequent demultiplexer. As explained earlier, this is difficult to assess when testing with an unframed p.r.b.s. according to O.151.

As an alternative you could check for errored seconds with a large number of errors - say greater than a few thousand, but less than the 34,000 which would qualify for an SES at 34 Mb/s. You might wish to add these to the SES count, assuming that they could cause a loss of frame-alignment in a subsequent demultiplexer.

As we saw earlier, the ES measurement is more complicated as we need to take account of the number of errors occurring during the error second at 34 Mb/s in order to calculate the effect at 64 kb/s.

You can take two approaches to this. Firstly, record the errors occurring in each errored second and compute the 64 kb/s result using the summation formula in G.821 Annex D (see page 25). Alternatively, you could inspect the error-second error counts and if the counts are not too variable (say, within a range of 10:1) you could take an average value for "n". The conversion is then simply calculated:

$$ES_{64\text{kb/s}} = ES_{34\text{Mb/s}} \cdot (n/N) \quad \text{for } n < N \quad (\text{for } n \geq N, (n/N) = 1)$$

Another alternative is to make measurements directly at the 64 kb/s rate if you have multiplex equipment connected. The HP 3784A has an optional 64 kb/s co-directional interface which you can use for this application. Alternatively the HP 3788A can be used directly at 64 kb/s.

Error performance plot

Here's an example printout from the HP 3784A which gives a comprehensive report on the error performance of the link. You have a complete record of error second events and after the measurement is finished, an analysis of error performance which you can check against the objectives calculated for your link. You'll also notice that the duration of alarms, slips, AIS and so on are recorded for the measurement period.

The trickiest decision is the measurement period. M550 recommends 3-4 days, but on a propagation limited radio system, weather and seasonal changes have a major effect and a single 3-4 day test could be misleading. It would be safer in this case to take a longer measurement over 1 month, or to sample different types of weather conditions over 3-4 day periods.

Graphical plot of results

This is an alternative graphical printout of alarms, BER and output jitter from a link under test. The graphical presentation makes it easy to spot the periods of degraded performance and to estimate the background error rate which exists under good propagation conditions. (For our example radio link this was a limit figure of 4×10^{-10} , see page 36).

HP 3784A digital transmission analyzer

I hope I have been able to explain some aspects of error performance standards, and how they are used in practical testing.

The new HP 3784A digital transmission analyzer offers a number of features that save test time and increase productivity:

- Fully automated jitter measurements
- Fully documented measurement results provide ready-to-file performance reports
- Stored set-ups and auto set-up of receiver save time and reduce operator errors
- One portable solution for all your test needs

But the HP 3784A is only one of the family of digital transmission analyzers from Hewlett-Packard.

HP 3788A error performance analyzer

For example, the HP 3788A error performance analyzer is ideal for end-user applications and for installing and maintaining digital services at customers' premises.

It operates at 64 kb/s, 704 kb/s and 2 Mb/s through standard G.703 interfaces with combined transmit and receive functions. It provides full error performance characterisation to G.821.

You can take the HP 3788A anywhere. It's housed in a rugged portable package and, with its internal rechargeable batteries, you can make tests out in the field. Simple keystroke operation reduces operator training to a minimum.

HP 3764A digital transmission analyzer

On the other hand, if you need to work up to 139 Mb/s with full G.821 analysis, the HP 3764A digital transmission analyzer offers one of the most versatile instruments in this field.

Again, it's a compact one-box product with combined transmit and receive capability. But with seven different versions available, you can specify just the measurement set you require. Anything from a simple cost-effective 139 Mb/s BER tester, to a multi-rate (0.7 Mb/s - 139 Mb/s) instrument with built-in clock synthesiser to 170 Mb/s. You can also specify full jitter generation and measurement capability at 139 Mb/s. Using the multiple 139 Mb/s outputs (optional), you can load the tributaries of a high-speed multiplexer and test a 565 Mb/s lightwave transmission system.

HP 37721A digital transmission analyzer

For maintenance and installation of transmission links from 704 kb/s to 139 Mb/s, the new HP 37721A is an ideal test tool. Rugged and portable, it combines a transmitter/receiver and built-in printer in a compact package. The large screen display makes the instrument easy to use and gives a very clear presentation of results in both alphanumeric and graphical form. The auto-setup facility automatically configures the test set to the rate, test pattern, code interface and level of the incoming signal. Nine stored setups ensure that required test patterns are available instantly. These ease-of-use features speed up testing and minimize mistakes.

With such a range of products to choose from, there's almost certainly a digital transmission analyzer in the Hewlett-Packard range to match your needs.

For more information, call your local HP sales office listed in your telephone directory or an HP regional office listed below for the location of your nearest sales office.

United States :

Hewlett-Packard Company,
4 Choke Cherry Road,
Rockville, MD 20850
(301) 670-4300

Hewlett-Packard Company,
5201 Tollview Drive,
Rolling Meadows, IL 60008
(312) 255-9800

Hewlett-Packard Company,
5161 Lankershim Blvd.,
No. Hollywood, CA 91601
(818) 505-5600

Hewlett-Packard Company,
2015 South Park Place,
Atlanta, GA 30339
(404) 955-1500

Canada :

Hewlett-Packard Ltd.,
6877 Goreway Drive,
Mississauga, Ontario L4V 1M8
(416) 678-9430

Australia/New Zealand :

Hewlett-Packard Australia Ltd.,
31-41 Joseph Street,
Blackburn, Victoria 3130,
Melbourne, Australia
(03) 895-2895

Europe/Africa/Middle East :

Hewlett-Packard S.A.,
Central Mailing Department,
P.O. Box 529,
1180 AM Amstelveen,
The Netherlands
(31) 20/547 9999

Far East :

Hewlett-Packard Asia Ltd.,
22/F Bond Centre,
West Tower,
89 Queensway,
Central, Hong Kong
8487777

Japan :

Yokogawa-Hewlett-Packard Ltd.,
29-21, Takaido-Higashi 3-chome,
Suginami-ku, Tokyo 168
(03) 331-6111

Latin America :

Latin American Region Headquarters,
Monte Pelvoux Nbr. 111,
Lomas de Chapultepec,
11000 Mexico, D.F. Mexico
(905) 596-79-33