

---

**Application Note 358-12**  
**Simplify Frequency Stability**  
**Measurements with Built-in**  
**Allan Variance Analysis**

**HP 5371A/5372A**  
**Frequency and Time**  
**Interval Analyzer**

---

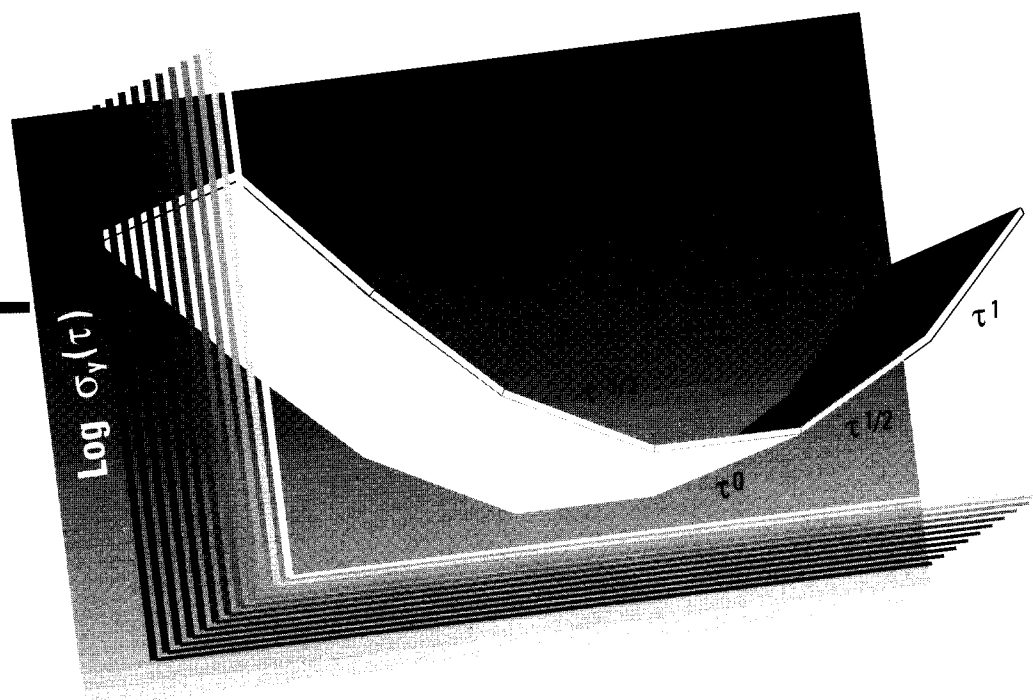

## **Purpose of this Application Note**

---

This application note is divided into three sections.

- Section I discusses frequency stability measurements with Allan variance calculations and the contribution of the HP 5371A/5372A to these measurements. The section then describes, in brief, a procedure for making these measurements and takes a quick look at measurement results.
- Section II provides detailed background information on frequency stability measurements using Allan variance.
- Section III, *Advanced Topics*, explores more specific technical information and measurements for frequency stability applications.



# Table of Contents

---

|                    |  |    |
|--------------------|--|----|
| <b>Section I</b>   | Introduction .....   | 5  |
|                    | The Instability Problem .....                                | 5  |
|                    | New Measurement Solutions .....                              | 5  |
|                    | Making the Measurements .....                                | 6  |
|                    | Measurement Results .....                                    | 8  |
|                    | Key HP 5371A/5372A Advantages .....                          | 9  |
| <b>Section II</b>  | Background: Measurement Basics .....                         | 10 |
|                    | Allan Variance .....   | 11 |
|                    | Overcoming Counter Resolution Limitations .....              | 12 |
|                    | Downconversion .....   | 13 |
|                    | Reference Source Selection .....                             | 14 |
|                    | Trigger Noise Errors .....                                   | 14 |
|                    | Statistical Estimates and Accuracy .....                     | 15 |
|                    | Automating HP 5371A/5372A Allan Variance Measurements ..     | 15 |
| <b>Section III</b> | Advanced Topics .....  | 17 |
|                    | Measuring White Phase Noise with Allan Variance .....        | 17 |
|                    | Noise Floor Measurements .....                               | 17 |
|                    | Resolution Noise Floor .....                                 | 18 |
|                    | Trigger Noise Floor .....                                    | 19 |
|                    | Periodic Signal Problems (Spurs, Bright-lines) .....         | 21 |
|                    | Dual Mixer Configuration Applications .....                  | 23 |
|                    | Local Oscillator Selection for Dual Mixer Applications ..... | 25 |
|                    | Delay Adjustment Procedure .....                             | 25 |
|                    | Summary .....  | 28 |
| <b>Appendix</b>    | A. HP K79-59992A Specifications .....                        | 29 |
|                    | B. Conversion Equations .....                                | 30 |
| <b>References</b>  | .....  | 31 |



## Section I

### Introduction

---

Stable and spectrally pure signal sources are used today in the fields of physics, digital communication, radar, space-vehicle tracking, and navigation, to name a few. Time domain short-term stability is an important specification for crystal oscillators and other sources. It is specified using the Allan variance calculation, which shows fractional frequency variations as a function of specified measurement times. Allan variance analysis is a useful tool for design, production test and quality screening of frequency sources.

### The Instability Problem

Random perturbations which show up as instabilities in the frequency or phase of an oscillator are caused by a number of different effects. Each type of noise process has distinct characteristics that can be measured using time domain and frequency domain techniques. It is important to measure these noise processes to determine if a device is meeting performance specifications, or to aid in the design process. Knowledge of the type and level of noise (white phase, flicker phase, random walk phase, flicker FM, random walk FM, and white FM) can verify design goals or indicate areas for design improvement.

In the past, dead time in counting hardware has limited the accuracy and flexibility of time domain stability analysis, and often computer programs had to be developed to do Allan variance analysis. In some cases, the measurement range was restricted, or complex hardware was required.

### New Measurement Solutions

The HP 5371A and HP 5372A Frequency and Time Interval Analyzers, combined with the HP K79-59992A Mixer/IF Amplifier in either the single mixer or dual mixer configuration, provide a powerful tool for time domain stability analysis of frequency sources. The analyzers have built-in Allan variance and root-Allan variance calculations as part of the Statistics results, making Allan variance checks quick and easy.

The analyzers' continuous measurement feature eliminates dead time between a series of frequency measurements. This removes uncertainties of dead time correction, and allows tau values as short as 10  $\mu$ s when using the K79 Mixer, or as short as 100 ns with the analyzers alone. Tau values are not restricted; the measurement will be made at the closest multiple of the IF period. An instrument controller can be used to automate Allan variance measurements, and make long-tau measurements of up to more than one thousand seconds.

## Making the Measurements

The most commonly used time domain short-term stability measure is root-Allan variance (calculated from a set of back-to-back frequency measurements, usually 100) at a specified tau value (gate time, or sampling interval in the HP 5371A/5372A terminology). One second is a commonly specified short-term stability tau value.

The basic procedure is as follows:

1. Use the configuration below (figure 1).

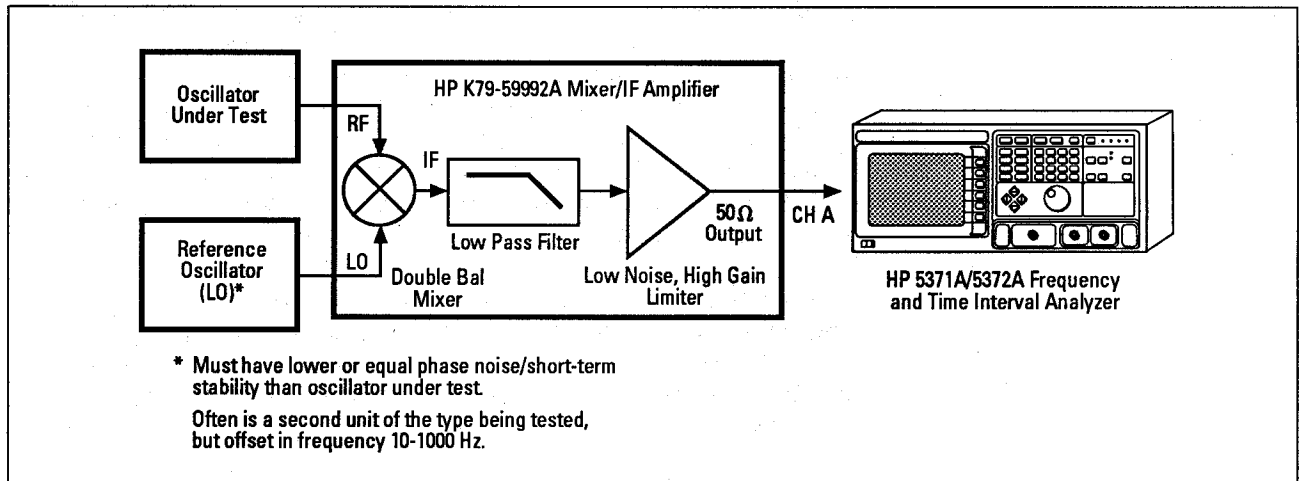

Figure 1. Single mixer method hardware configuration for short-term stability measurements.

2. Select the reference Local Oscillator (LO). It must have better root-Allan variance performance at all taus of interest, or it can be an offset version of the Device Under Test (DUT), and it is assumed to have the same noise level. In the latter case, the DUT noise can be considered to be  $.707 \times$  the measured result.
3. Select the IF frequency between 10 Hz and 100 kHz. 500 Hz to 1000 Hz is usually ideal.
  - The IF period sets the minimum tau value that can be analyzed.
  - The IF is often determined by available sources for the reference.

4. Set up the HP 5371A/5372A menus as shown below (assumes a 10 MHz DUT, 100 measurements and a tau of 0.1 second using an HP 5372A):

```

HP 5372A Frequency and Time Interval Analyzer

Frequency A:          999.999 834 MHz

FUNCTION
Frequency      Measurement Channel A
Acquire        block of 100 meas
Pre-trigger    Off      Total Meas = 100

Internal Sampling Arming Mode
Block Holdoff:
Arm a block of measurements automatically

Sample Arm:
Arm sampling on meas channel after
100.000000 ms intervals

Acquisition Time/Block = 10.000000 s
  
```

Figure 2. Function Menu

```

HP 5372A Frequency and Time Interval Analyzer

Waiting for input signal...
Frequency A:          0 V

INPUT
Separate Input Channels
Trigger Event:
Slope Mode Level
Chan A: Pos Manual 0 V
Chan B: Pos Ext Auto 50 % 0 V
Chan C: POS MANUAL 0 V
Ext Arm Level 0 V

Channel A Channel B Channel C
Input Pod HP 54002A HP 54003A -----
Impedance 50 Ω 1 MΩ 50 Ω
Bias Level GND GND GND
Attenuation 1:1 1:1 0 %
Hysteresis No No -----
Max Input 2 V peak 2 V peak +28 dBm
  
```

Note:  
Channel B is not used in this setup. Disregard the settings for the HP 54003A Input Pod.

Figure 3. Input Menu

```

HP 5372A Frequency and Time Interval Analyzer

Frequency A:          999.999 834 MHz

MATH
Channel Stats Math Limits Carrier Freq
A On On Off Auto 10
B Off Off Off
C Off Off Off
Phase Result Set Ch A Reference
Offset Normalize Scale
A 0E+00 10.000000E+00 1.000000E+00 Clear Ch A Reference
B Disabled Disabled Disabled
C Disabled Disabled Disabled

Reference Low Limit High Limit
A 0E+00 Disabled Disabled
B 0E+00 Disabled Disabled
C 0E+00 Disabled Disabled

Display = [((Result-Ref)/Norm)+Offs]*Scale
  
```

Note:  
Channel A Math is "On" and the Normalize value is set to the DUT frequency being measured.

Figure 4. Math Menu



- Press the Numeric Results hardkey and select Statistics results. Read the root-Allan variance value.

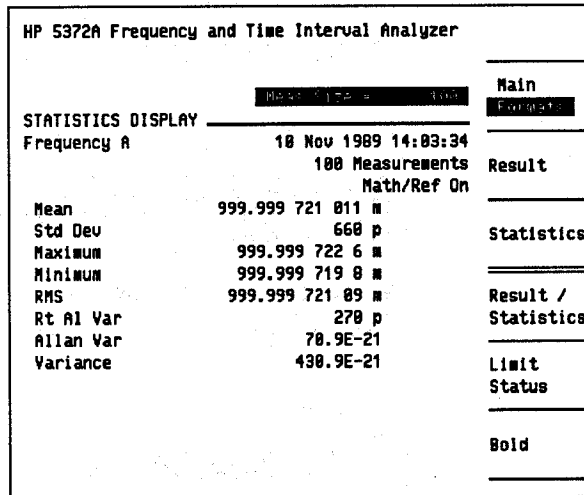

**Note:**  
The Root Allan Variance is  $270 \times 10^{-12}$  or  $2.7 \times 10^{-10}$  in this example.

Figure 5. Statistics screen

- Repeat the measurement for each tau value of interest. (Enter the tau values as intervals in the Sample Arm section of the Function Menu).

## Measurement Results

Results can be shown as a single tau value, as provided on the Statistics screen, or they may be plotted manually to provide a root-Allan variance vs. tau graph. The example shown in figure 6 is a 10 MHz oscillator measured with a second oscillator of the same type, offset 500 Hz, as the reference. The result is the combination of both units' instabilities.

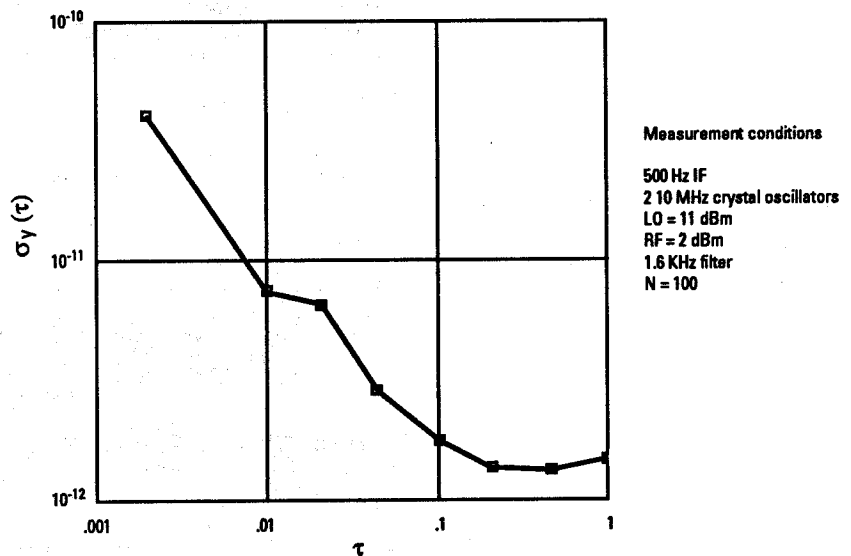

Figure 6. Example  $\sigma_y(\tau)$  vs.  $\tau$  plot for a 10 MHz crystal oscillator DUT.

## **Key HP 5371A/5372A Advantages**

---

- Continuous measurements mean no dead time corrections
- Built-in Allan and root-Allan variance calculations
- 2-Channel simultaneous frequency measurements for dual mixer method (refer to "Downconversion" section)
- Interval Sampling mode allows a wide range of tau values
- Binary data dump for long tau measurements
- HP K79-59992A Mixer/IF Amplifier available for downconverting sources with frequencies up to 500 MHz
- Frequency vs. Time displays for warm-up and turn-on studies
- General purpose time and frequency analysis

## Section II

### Background: Measurement Basics

Random perturbations that appear as instabilities in the frequency of an oscillator can be represented in either the frequency domain or the time domain.<sup>1</sup> Each method has its advantages and often both approaches are required to completely characterize a given signal source.

In general, when measuring phase noise at frequency offsets from the carrier ranging from a few Hz to tens of MHz, the frequency domain is used. When investigating close-in noise ( $\ll 1$  Hz) or short-term stability, the time domain approach is often the measurement of choice. Figure 7 shows the relation of these two methods of measuring frequency stability.

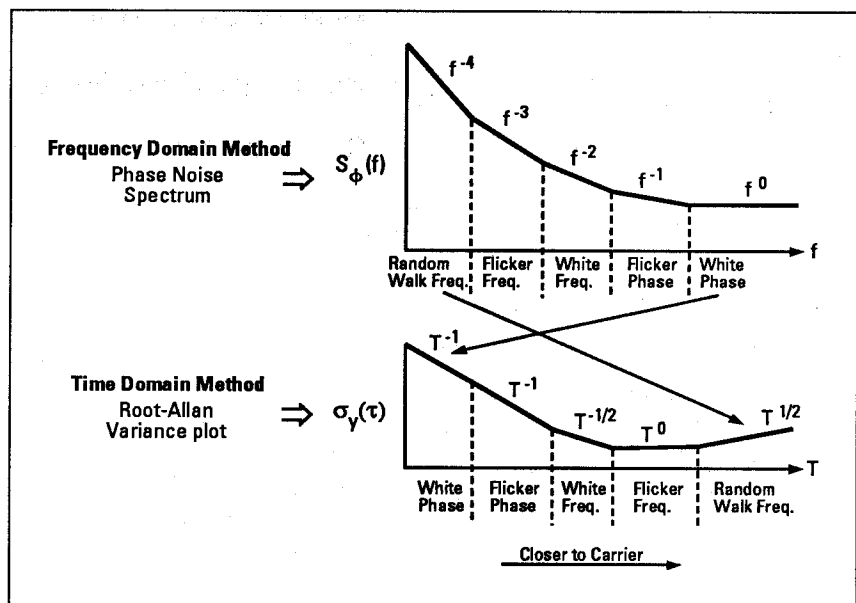

Figure 7. The two basic approaches to measuring frequency instability effects show noise processes differently. Each method has advantages and disadvantages.

Historically, the time domain method was the first technique used to measure frequency stability. This was to simply measure the signal's frequency or period with an electronic counter. A number of approaches measuring frequency, period, or time interval have been used to obtain the raw information required to analyze a source's stability. Counter resolution and dead time have always been limiting factors, but the availability of commercial electronic counters and their ease of use encouraged test design based on counting methods. Today it is the accepted technique for measuring short-term stability.<sup>2</sup> The HP 5371A/5372A Frequency and Time Interval Analyzers have eliminated counting dead time, thus removing one of the major issues plaguing time domain stability measurements.

<sup>1</sup> Time domain in frequency stability measurement refers to measuring timing parameters of a signal that can be used to calculate fractional frequency differences.

<sup>2</sup> Military specification MIL-0-55310B, General Specification for Crystal Oscillators. May 1988. This specification covers all aspects of testing crystal

## Allan Variance

The key to time domain stability analysis is Allan variance, a statistical computation of the variance of fractional frequency deviations. Proposed by David Allan of the NBS (now the NIST), this technique allows convergence of variance values for the basic types of random noise processes found in sources for a limited number of frequency measurements.

Allan variance also has mathematical relationships to phase spectral density. This fact allows conversion between the two domains (time and frequency)<sup>3</sup>. It is always best to measure in the domain that directly provides the required results. This is because differences in measurement errors and assumptions may result in non-matching values after conversion. Conversion is only recommended in cases where the desired domain cannot be measured directly. One example is random walk FM and flicker FM noise that may occur too close to the carrier to measure easily with normal phase detector/spectrum analysis techniques. These noise types are easily measured using the time domain technique.

Allan variance is defined assuming N frequency measurements are made at a given averaging time, called tau, (gate time, or sampling interval in the HP 5371A/5372A) and that there is no dead time between measurements. The Allan variance calculation is shown below:

$$\sigma_y(\tau) \cong \frac{1}{f_0} \sqrt{\frac{\sum_{k=1}^{N-1} (f_{k+1} - f_k)^2}{2(N-1)}}$$

$f_0$  = Oscillator nominal frequency  
 $f_k$  = k<sup>th</sup> frequency result  
 $N$  = Number of measurements  
 $\tau$  = tau = Averaging time (Gate Time, Sampling Interval in HP 5371A/5372A)

By making frequency measurements at different averaging times (taus) and calculating the Allan variance for each measurement set, a plot of the results as a function of tau is often made to aid in the analysis. The most common plot is root-Allan variance (called Sigma<sub>y</sub>(tau) vs. tau. See figure 8.

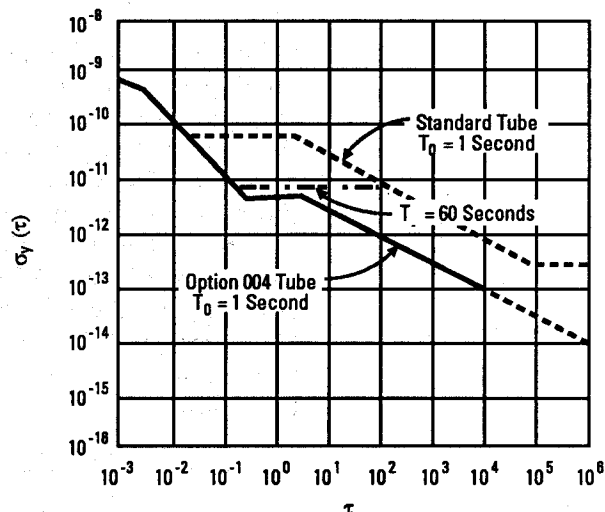

Figure 8. Short-term stability specification of the HP 5061B Cesium Standard

<sup>3</sup> R. Burgoon and M.C. Fischer, *Conversion Between Time and Frequency Domain of Intersection Points of Scopes of Various Noise Processes*. Proc. 32nd Annual

By analyzing the slopes and magnitudes of the data on this plot, important information about oscillator performance and design can be obtained.

Phase noise in oscillators comes from two different sources; additive voltage fluctuations and direct parameter modulation. Additive noise is generally caused by thermally-generated voltage fluctuations that are added to the carrier signal and result in phase and amplitude fluctuations. This type of noise shows up as the noise floor at large frequency offsets from the carrier (short tau values) and is flat (white) phase noise. See figure 7, on page 10.

The second type is modulation noise. The causes of this type are not as well understood. The most well known is flicker (1/f) noise. This is caused by direct phase or frequency fluctuations in the resonant device or by phase fluctuations in other electronic components of the oscillator. Depending on the bandwidth of the 1/f flicker noise and where it originates in the system, noise with other exponents of f may be present at the output. In closed-loop feedback oscillator configurations, 1/f<sup>3</sup> and 1/f<sup>2</sup> phase noise may exist, depending on the loop bandwidth.

Another type of modulation noise that occurs at very low frequencies (f < 0.1 Hz) is random walk of frequency noise. This frequency noise varies as 1/f<sup>2</sup>, (or 1/f<sup>4</sup> of phase). For characterizing noise at these very low frequencies, the time domain measurement technique may be the only way to measure the the device. These measurements use large tau values, as the energy is close to the signal's carrier frequency. See figure 8 (previous page).

## Overcoming Counter Resolution Limitations

The ability of a counter to resolve small frequency changes is determined by the counter's time resolution. Since time and frequency are related, the following relationship is useful for frequency stability analysis:

$$\left| \frac{\Delta F}{F} \right| = \left| \frac{\Delta T}{T} \right|$$

For the purpose of estimating error sources, the root-Allan variance can be considered to be the same magnitude as the rms fractional frequency deviation from the mean at a given tau, Δ F, divided by the nominal frequency, F. It is a dimensionless quantity. To determine if a counter has enough time resolution to measure a given source, compare the counter's Δ T/T to the desired root-Allan variance value. Δ T is the counter's resolution and T is the tau value. Using T=tau=1 second, an estimate of the counter's resolution limit can be made. The HP 5371A/5372A resolution is 150 ps rms, or 1.5 x 10<sup>-10</sup>. So the root-Allan variance limit imposed by the counter resolution (at tau = 1 sec) is in the order of 1.5x10<sup>-10</sup>. See below:

$$\frac{\Delta T}{T} = \frac{1.5 \times 10^{-10} \text{ sec}}{1 \text{ sec}} = \frac{\Delta F}{F}$$

Note that for longer tau values, the resolution noise floor decreases (1/tau relationship). For a tau of 100 seconds, this noise floor would be  $1.5 \times 10^{-12}$  ( $1.5 \times 10^{-10}/10^2$ ).

## Downconversion

It is clear that the resolution of counters is not high enough to measure frequency stability directly, so downconversion is used to provide additional resolution. With downconversion, the resolution floor is reduced by the downconversion factor. If a 10 MHz oscillator is downconverted to an IF (beat frequency) of 1 KHz, the downconversion factor is  $10^4$  ( $10^7/10^3$ ). For the example above, this downconversion would reduce the counter's resolution noise floor from  $1.5 \times 10^{-10}$  to  $1.5 \times 10^{-14}$ , clearly enough to measure today's oscillators at 1 second tau. Downconversion may be single channel, called the heterodyne technique (see figure 9), or may involve two channels, called the Dual Mixer Time Difference (DMTD) technique (see figure 10).

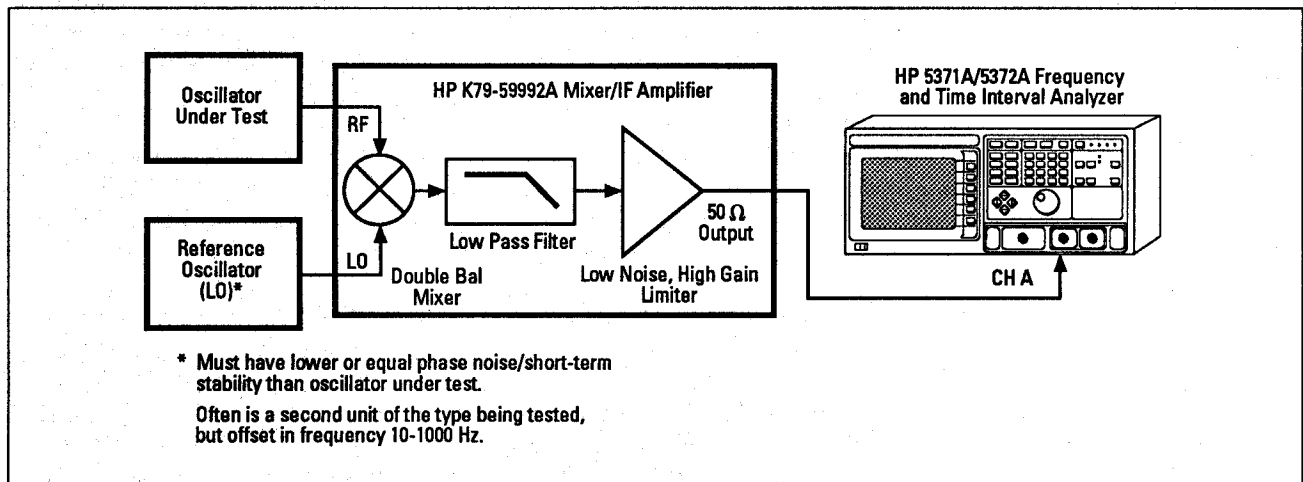

Figure 9. Single mixer heterodyne downconversion technique overcomes counter resolution limitations.

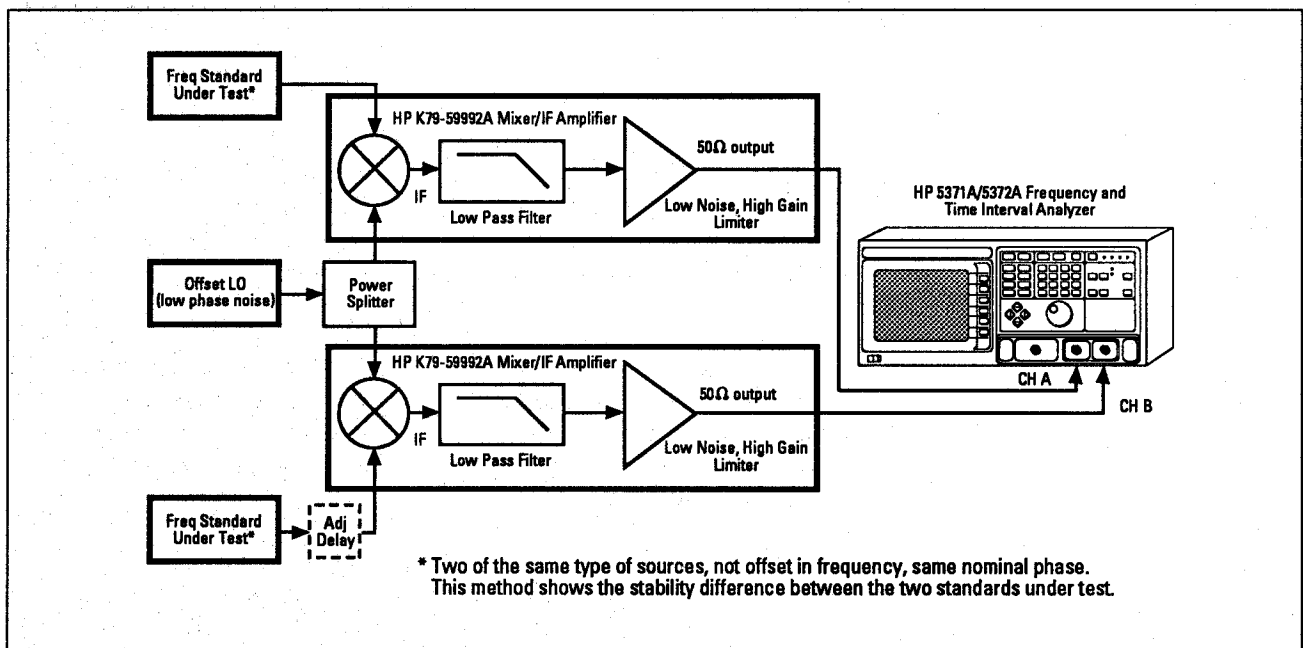

Figure 10. Dual mixer time difference technique is used to compare two primary standards.

## Reference Source Selection

With any downconversion method, the stability measured is the combination of the DUT and the reference oscillator. References must be selected to be lower noise than the DUT at all tau values of interest. The root-Allan variance measured is the square root of the sum of the squares of the DUT and reference root-Allan variance values. If the reference is three times better than the DUT, the measured result will be 5.4% greater than the actual DUT due to the reference's contribution. Practically, it is not possible to find a reference that is three times better than the DUT, therefore, sources of equal noise are often used. In this case, neither the DUT nor the reference oscillator are worse than the measured value and each could be 0.707 times the measured value. Broadband additive voltage noise on the reference and DUT signals also can greatly increase the noise floor of the setup. See "Trigger Noise Errors" below.

## Trigger Noise Errors

Noise (broadband additive energy) on the signal being measured will cause the trigger circuits (or any amplifier) to convert noise voltage to phase (time) errors. This is called "trigger error" in counters and is dependent on the slew rate of the signal and the noise energy present. The higher the slew rate, the lower the trigger error for a given level of noise. For most time domain measurement setups, trigger noise is the limiting factor in the noise floor performance of a measurement system. (Downconversion easily removes resolution from being a significant error source.)

To reduce the trigger error of the HP 5371A/5372A, fast slew-rate signals are presented to the analyzer's inputs. These are generated in a high-gain, low noise limiter circuit contained in the HP K79-59992A Mixer/IF Amplifier (K79). In addition, the HP 5371A/5372A INPUT MENU is set for MANUAL trigger level at 0 volts, eliminating any jitter introduced by the automatic trigger level detection. These measures reduce trigger errors in the analyzer, allowing the first gain stage in the K79 to be the main circuit determining the amount of amplitude to phase conversion (trigger noise).

So far we have not reduced the noise energy present. We have only reduced the analyzer's sensitivity to the noise. To reduce the noise, the noise-bandwidth must be reduced. A low-pass filter with adjustable cutoff frequencies is also included in the K79 unit. This cutoff is normally set above the IF signal frequency, reducing the higher frequency noise energy input to the limiter.

The time domain method cannot discriminate between the DUT's white phase noise and trigger noise ( $1/\tau$  slope region of the root-Allan variance vs. tau plot). So it is important to reduce trigger noise as much as possible. Having low-noise DUT and reference source signals is key. See Advanced Topics, Trigger Noise Floor for additional information.

A quick way to check if trigger noise or the DUT's white phase noise is being measured is to lower the DUT signal level to the mixer, thus reducing the signal's slew rate. If the  $1/\tau$  region of the root-Allan variance plot increases by the same factor, trigger error is

## Statistical Estimates and Accuracy

suspected. If changing the amplitude of the inputs does not change the  $1/\tau$  region results, then white phase noise is being measured, and the trigger noise floor is lower than the white phase noise from the DUT and reference.

When measuring Allan variance, the statistics of the measurement must be considered when estimating the accuracy of any result. Since Allan variance is an estimate of a random process, the confidence that the estimate is indeed the actual Allan variance is related to the number of independent frequency measurements ( $N$ ) used for the calculation.

For time domain analysis, the uncertainty decreases as  $\frac{1}{\sqrt{N}}$ . The rms uncertainty is  $\frac{1}{\sqrt{N}} \times 100\%$ . Thus, if 100 measurements were made, the rms uncertainty is  $\pm 10\%$ . To increase the confidence of the estimate, increase the number of measurements.

Other issues that affect accuracy of the measurements are measurement noise floor, noise performance of the reference source, and resolution of the counting hardware. For long taus, drift in the counter's time base will cause errors in the actual tau that is being measured, but these are usually very small. The largest sources of error are usually the trigger noise for short taus, and the reference stability for long taus, assuming the single mixer configuration.

When using the HP K79-59992A and HP 5371A/5372A for Allan variance analysis, noise floor data presented in this note is typical of what can be expected with good measurement technique and similar quality sources.

To understand measurement errors, noise floor measurements are important, and the dual mixer method is the best way to accomplish these measurements. See Advanced Topics.

## Automating HP 5371A/5372A Allan Variance Measurements

The easiest way to make Allan variance measurements is by using the HP 5371A/5372A front panel setup menus to define the number of frequency measurements and sampling interval ( $\tau$ ). Statistics are turned ON and the MATH menu is activated to Normalize by the DUT's nominal frequency. This provides root-Allan variance data in the  $\frac{\Delta f}{f}$  form. The procedure is outlined in the "Making Measurements" section of this note. To automate this process, an external instrument controller is used to control the analyzer and process data.

### Longer Tau Measurements

Note that from the front panel, the maximum tau value possible is 8 seconds. Longer tau values can be obtained by:

1. Combining frequency results of shorter taus (possible because of no dead time between measurements), or
2. by processing events/time information into frequency data at desired tau values.



## 1. Combining Frequency Results

To combine frequency values, take the average of N adjacent measurements, where N is calculated by dividing the desired tau by the sampling interval selected in the function menu. For example, if a tau of 100 seconds is desired, the following method can be used:

- a. Set up the FUNCTION menu to gather 1 block of 1000 measurements.
- b. Select Interval Sampling of 5 seconds.

This will accumulate 5000 seconds worth of data (1000 frequency measurements, each made over a 5 second tau with zero dead time between measurements).

By averaging 20 of these consecutive frequency results in an external instrument controller, one 100-second tau result is obtained. 50 measurements at 100-second tau can be obtained in this manner. Other combinations can be selected to derive a number of tau values from one run of data. If larger memory is available, more measurements and, thus, longer taus are possible.

In this case the root-Allan variance equation is calculated in the external controller, and the HP 5371A/5372A's internal firmware is not used. The analyzer would, however, show root-Allan variance for the 5 second data, if statistics were enabled.

## 2. Processing Events/Time Information

To process events and time information directly in an external controller, the HP 53700A Continuous Measurement Software may be used with the HP 5371A only. It contains three separate programs for increasing the measurement time (tau).

These programs rapidly transfer unprocessed events and time information in binary format to an HP Series 300 computer using Basic 4.0, a 5.0 or an HP Vectra Workstation with the HP BASIC Language Processor System. Then frequency calculations are performed that insure truly continuous measurements. As with the previous method, the Allan variance calculation and results must be calculated in the external controller.

The data shown in this paper was analyzed using an HP Series 300 computer with an HP BASIC program to automate the measurement, process event and time information, calculate the root-Allan variance and plot the results. This demonstration software\* is available at no charge. To receive a diskette, return the enclosed reply card.

---

\* This software is offered at no charge as an example of the techniques described in this application note. Software performance is not warranted by Hewlett-Packard.

## Section III

### Advanced Topics

---

#### Measuring White Phase Noise with Allan Variance

This section provides more specific technical information and measurement suggestions that may aid in frequency stability applications. It assumes a knowledge of time domain techniques and access to technical papers in the field for reviewing the theoretical background.

Allan variance analysis is not ideal for measuring white phase noise. The Allan variance calculation, if looked at as a filtering function in the frequency domain, is a filter with nulls at frequencies of  $N/\tau$  and a slow roll-off of the lobes as a function of frequency. This means that if phase noise is flat with frequency (white phase noise), the Allan variance result will have contained information from many lobes. This is in contrast to phase noise that is rolling-off at  $1/f^2$  or greater, that will mostly be seen in the filter's main lobe. Another way to look at this is to assume a given  $\tau$  value. One might expect that the value for root-Allan variance at that  $\tau$  relates to phase noise energy in the frequency region of  $1/(2 \times \tau)$  - where the main lobe of the filter occurs in the frequency domain. But actually the value is the result of a contribution from many of the lobes.

This problem is important when downconversion is used. The mixing process will alias broadband energy into the IF passband. The only way to prevent this aliasing is to bandpass filter the DUT and reference LO signals with high Q filters to remove the broadband information BEFORE mixing.

As mentioned earlier, the time domain method combines trigger noise and white phase noise in the  $1/\tau$  portion of the  $\sigma_y(\tau)$  vs.  $\tau$  plot. It is therefore important to know the trigger noise floor of the setup to determine if the setup can actually measure the DUT's white phase noise (with all its aliased energy included).

#### Noise Floor Measurements

The most straightforward way to measure the system noise floor is to use the dual mixer configuration. In this method, both channels receive the same signals. See figure 11. Allan variance is calculated on the difference in frequency values of the two channels. Frequency changes common to both channels (the phase noise differences between the two sources) subtract out, leaving only system-related errors. This measurement process can use "non-ideal" sources, and is therefore much easier than attempting noise floor analysis with the single mixer case, where "ideal" (lower phase noise than the system noise floor) sources would be required to see the system noise floor. Good, low-noise sources should be used in the dual mixer case for best results. (See Local Oscillator Selection and Delay Adjustment Procedure information on page 25).

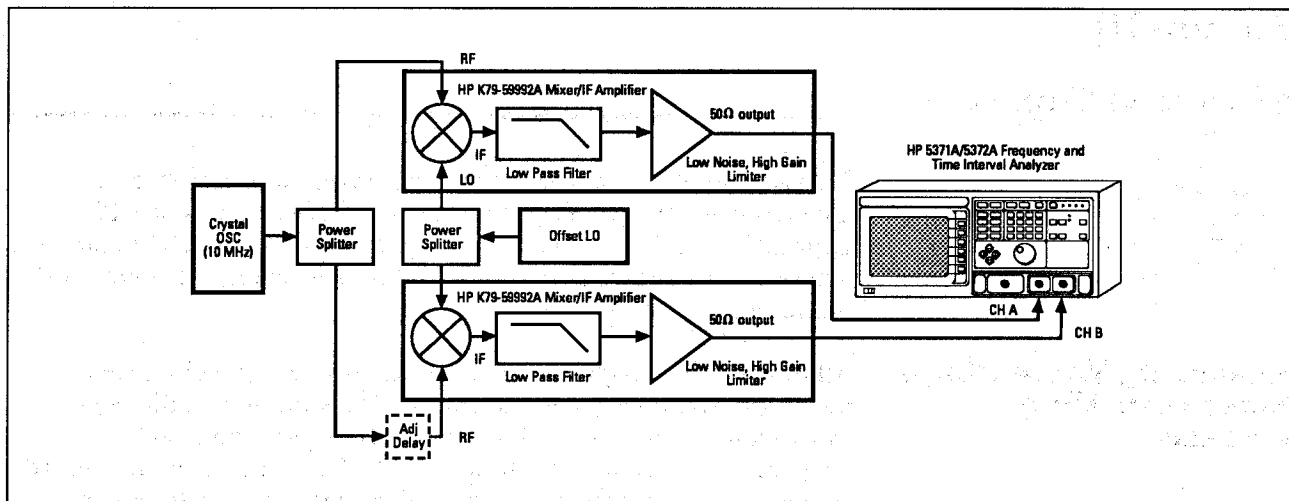

Figure 11. Using the dual mixer configuration to measure the system's noise floor.

For the results shown in this section, the K79-59992A Mixer/IF Amplifier has been characterized using crystal oscillators for both DUT and LO signals. These are the same type of oscillators that will later be used in the single mixer configuration. Thus, the trigger noise floor measured will be the same when the oscillators are tested in the single mixer case. Since trigger noise is usually the limiting factor in total system noise floor, it is important to test using the same signal levels (and additive broadband noise contained on the signals) that will be used in actual measurements. Otherwise, the  $1/\tau$  portion of the results are suspect if trigger noise conditions change between noise floor testing and actual measurement.

Two types of errors affect the noise floor. One is trigger error-related and the other is resolution-related. Both types are discussed below.

### Resolution Noise Floor

The resolution noise floor is caused by the basic time resolution of the counting hardware. To measure it, trigger errors must be eliminated. This is accomplished by driving the External IF input (the input to the filter and amplifier section of the K79) with a fast rise time, stable squarewave at various IF frequencies. The fast rise time of the squarewave essentially eliminates the trigger error and the resolution floor can be seen.

A very low-jitter signal can be obtained by locking an HP 8904A Multifunction Synthesizer to the HP 5371A/5372A's 10 MHz reference clock, and requesting special frequencies. This source is stable enough to measure a single channel configuration as well. See figure 12. (The HP8904A has a large amount of broadband noise on the output signals. The fast rise time of the squarewave reduces this potential trigger noise problem. The other output waveforms are too noisy for testing noise floors of Allan variance measurement equipment). Figure 13 shows the results of the resolution noise floor measurement. Note that very low noise floors occur at large downconversion factors (low IF values). Unfortunately, trigger noise will make many of the very low noise floor values unobtainable.

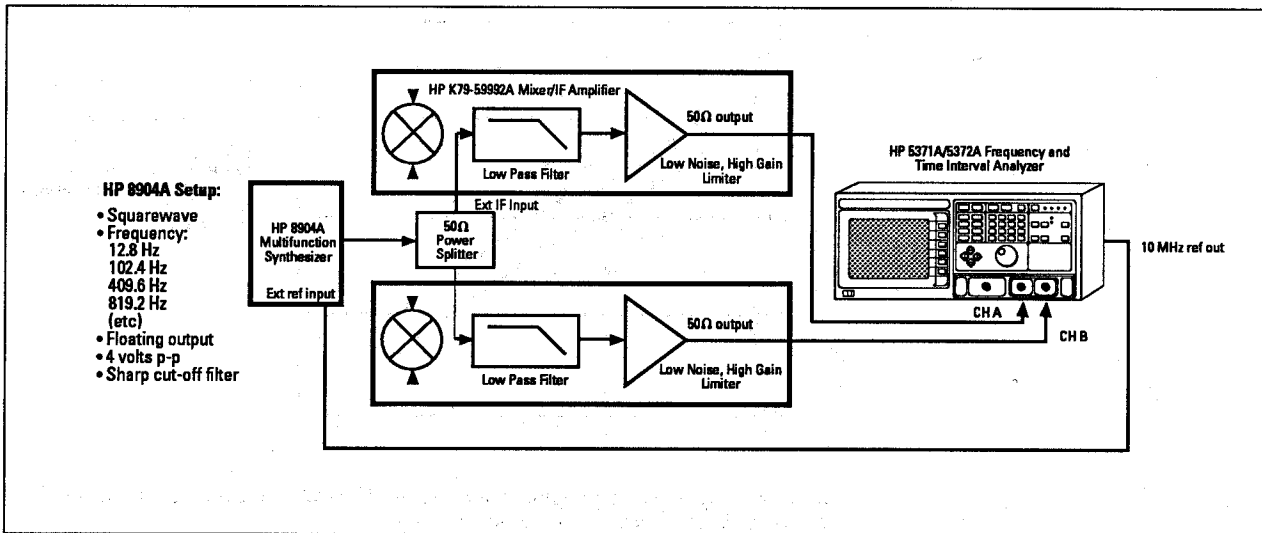

Figure 12. Resolution noise floor test setup. The HP 8904A functions as a "perfect" (no jitter) source in this configuration.

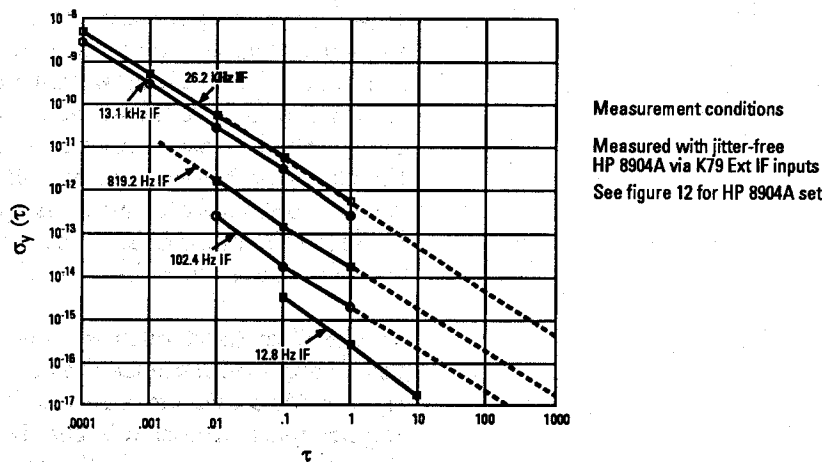

Figure 13. Resolution noise floor results (referenced to 10 MHz) using dual mixer setups. These values cannot always be obtained in actual practice due to trigger noise effects.

### Trigger Noise Floor

To measure the trigger error noise floor, two 10 MHz oscillators (offset 500 Hz) are used to drive both channels' RF and LO mixer ports via signal splitters in the dual mixer setup (see figure 11 on page 18). Now, real DUT-like signals are being mixed, filtered and amplified in both channels, and the resulting noise floor can be measured. The effect of the IF bandwidth (filter settings), the mix input levels, and the delay of Channel A to Channel B can be investigated.

If trigger error noise is being measured, then the amplitude (which affects the signal's slew-rate) of the mixer input will affect the result. A decrease in amplitude level of 10 dB should increase the root-Allan variance result by a factor of about three times. See figure 14.

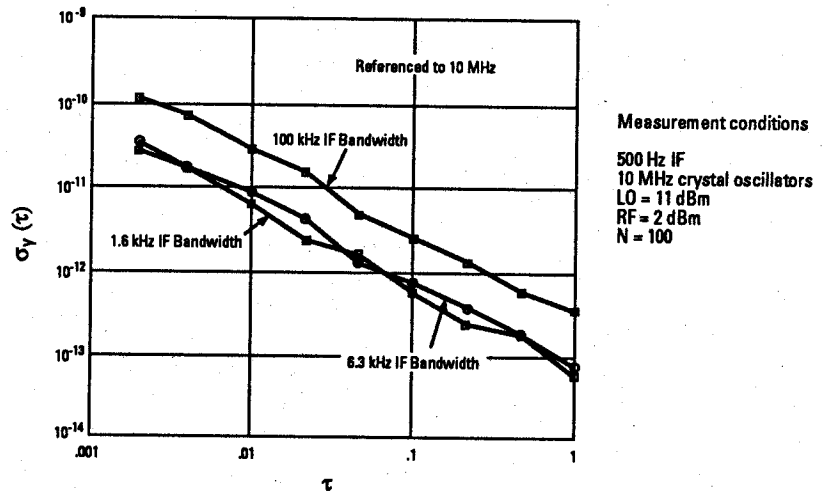

Figure 15. Trigger noise as a function of IF Bandwidth setting. For low noise DUTs, the IF Bandwidth may not be too critical.

### Periodic Signal Problems (Spurs, Bright-lines)

The time domain method using Allan variance is intended to analyze random processes that affect phase and frequency of a source. Mathematics that are used to convert Allan variance data to spectral data assume random processes. (See Conversion Between Domains below). However, in all test setups there are usually some periodic signals interfering with the frequency stability measurement. Power-line frequencies, other oscillator signals, radio TV stations, even vibration-induced line-related signals from instrumentation fans or heavy electrical equipment in the building are all possible. (Vibrations can affect crystals, causing PM or FM due to acceleration sensitivity). These "spurs" or bright lines, as they are called in frequency domain analysis, are easily seen in frequency domain phase noise plots. Often frequency domain techniques are necessary to find and reduce these periodic interferences. But what do these signals do to the root-Allan variance results?

Periodic signals will cause the shape of the root-Allan variance plot to change, and may be interpreted incorrectly as random process information. By understanding the characteristic shape of periodic signals as seen on a root-Allan variance plot, one can be aware that interference is occurring. The root-Allan variance values can then be analyzed with the interference effects in mind.

Recalling that the Allan variance calculation filter shape in the frequency domain has nulls at frequencies at multiples of  $1/\tau$ , and peaks at odd multiples of  $1/(2 \times \tau)$ , the shape of the root-Allan variance plot with a periodic phase/frequency signal present is more understandable.

To demonstrate the effect of periodic signals, a 10 MHz signal was frequency modulated at a 60 Hz rate and 200 Hz p-p deviation using an HP 8640B AM/FM Signal Generator. The modulated 10 MHz signal was then measured with a single mixer setup, using a high-quality crystal oscillator for the LO. The same source without modulation was previously measured to show the true root-Allan

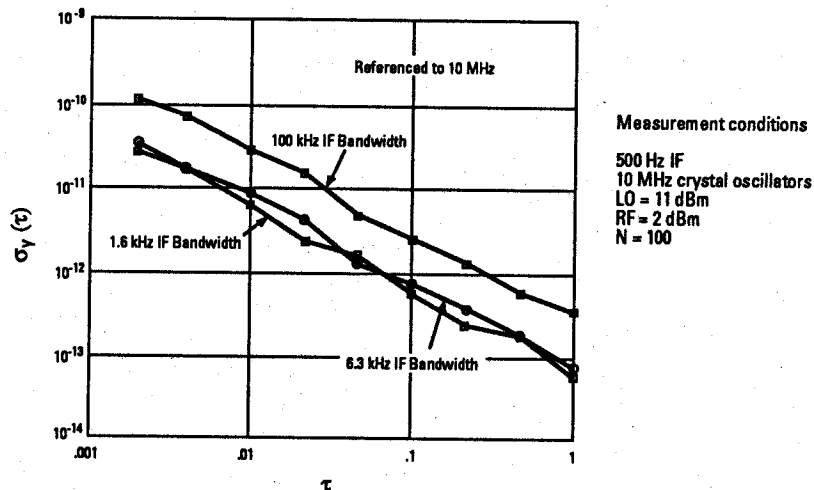

Figure 15. Trigger noise as a function of IF Bandwidth setting. For low noise DUTs, the IF Bandwidth may not be too critical.

## Periodic Signal Problems (Spurs, Bright-lines)

The time domain method using Allan variance is intended to analyze random processes that affect phase and frequency of a source. Mathematics that are used to convert Allan variance data to spectral data assume random processes. (See Conversion Between Domains below). However, in all test setups there are usually some periodic signals interfering with the frequency stability measurement. Power-line frequencies, other oscillator signals, radio/TV stations, even vibration-induced line-related signals from instrumentation fans or heavy electrical equipment in the building are all possible. (Vibrations can affect crystals, causing PM or FM due to acceleration sensitivity). These “spurs” or bright lines, as they are called in frequency domain analysis, are easily seen in frequency domain phase noise plots. Often frequency domain techniques are necessary to find and reduce these periodic interferences. But what do these signals do to the root-Allan variance results?

Periodic signals will cause the shape of the root-Allan variance plot to change, and may be interpreted incorrectly as random process information. By understanding the characteristic shape of periodic signals as seen on a root-Allan variance plot, one can be aware that interference is occurring. The root-Allan variance values can then be analyzed with the interference effects in mind.

Recalling that the Allan variance calculation filter shape in the frequency domain has nulls at frequencies at multiples of  $1/\tau$ , and peaks at odd multiples of  $1/(2 \times \tau)$ , the shape of the root-Allan variance plot with a periodic phase/frequency signal present is more understandable.

To demonstrate the effect of periodic signals, a 10 MHz signal was frequency modulated at a 60 Hz rate and 200 Hz p-p deviation using an HP 8640B AM/FM Signal Generator. The modulated 10 MHz signal was then measured with a single mixer setup, using a high-quality crystal oscillator for the LO. The same source without modulation was previously measured to show the true root-Allan

variance of the source, see figure 16. Note that the nulls of the filter response indicate the true root-Allan variance of the source, the peaks only relate to the interfering modulation. Thus, if periodic signals are present, there may be dips and peaks in the root-Allan variance plot. The dips indicate the random process information, the peaks indicate the interference energy.

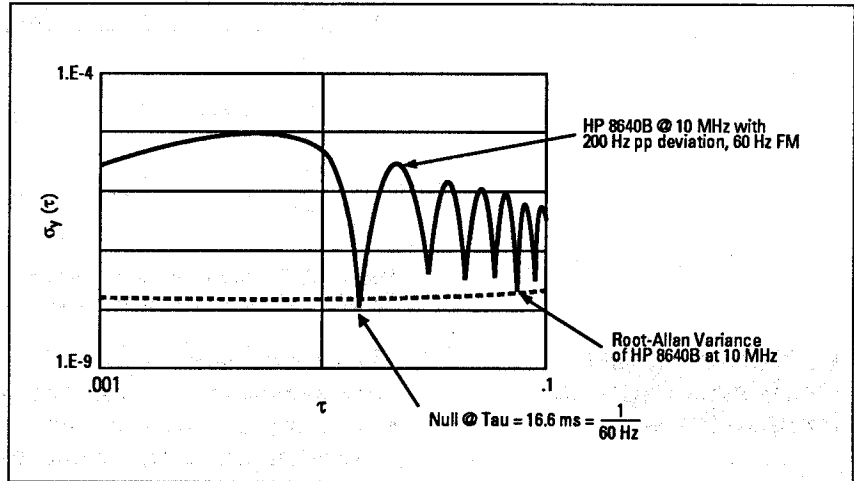

Figure 16. Periodic signals distort root-Allan variance results. Null values indicate true random instabilities, peaks indicate periodic instabilities (spurs, bright lines).

To see this effect, investigate the region of the graph at tau values in multiples of  $1/(2 \times 60 \text{ Hz})$  or multiples of 8.33 ms. In order to clearly see these dips and peaks, analysis must be done at many tau values spanning the period of the periodic signal. If only a few tau points/decade are plotted, the interference may go unnoticed, but is still affecting the results. These plots were made with 40 points/decade, linearly spaced on the log axis.

Low-level interfering signals near the DUT frequency can easily be seen in the root-Allan variance results. To demonstrate this effect, an interfering signal is added at the RF input to the mixer. The DUT is a 10 MHz crystal oscillator. The added signal's frequency is 10 MHz + 60 Hz, which mixes down to 60 Hz above the DUT signal at the IF. Figure 17 shows the result with the interfering tone at 80 dB below the DUT. Figure 18 shows the same setup with 100 dB attenuation. Again notice that the value at the nulls is the DUT's actual root-Allan variance (allowing for the statistical uncertainty of only 20 measurements).

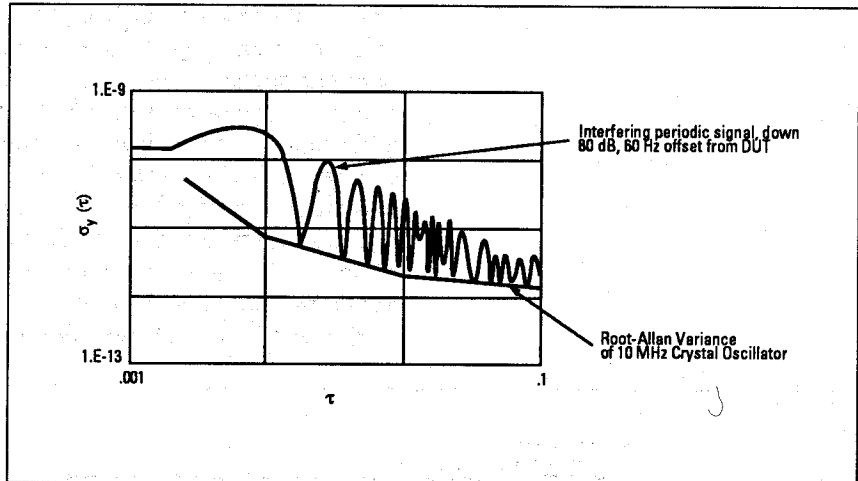

Figure 17. Periodic interfering signals or DUT modulation at low levels are easily seen in the root-Allan variance results. Nulls of the data show true DUT performance.

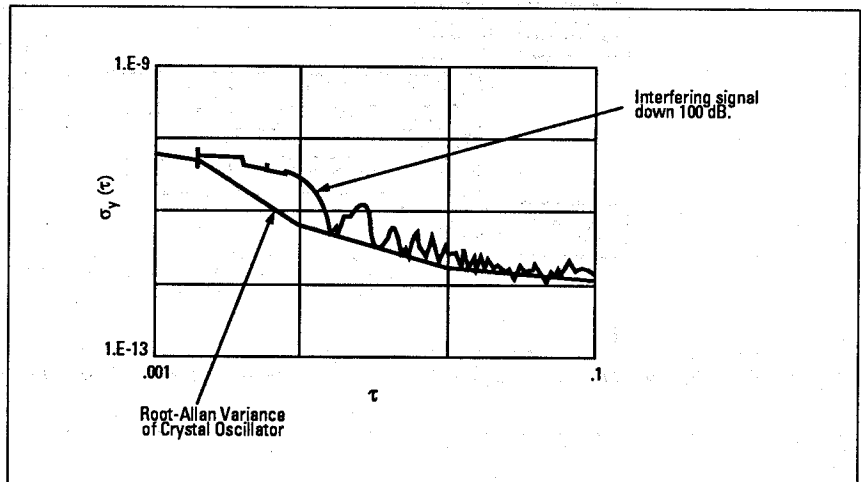

Figure 18. Extremely clean signal environments are required for high quality frequency stability measurements. Here the interfering signal is 100 dB below the DUT, but is easily seen in the results.

Since frequency stability measurements are very sensitive, and very low levels of instability are often being measured, periodic signals (Additive, FM, PM) are a major concern and careful setup and control of environmental conditions is required for good results (AM is reduced by triggering at zero-crossings, but still may have an effect if waveforms are not symmetrical). Frequency domain equipment, such as the HP 3048A Phase Noise Test System, is an important tool for understanding the levels and sources of spur energy.

## Dual Mixer Configuration Applications

The benefit of the dual mixer method is that two DUTs (of the same frequency) that are far more stable than any available reference LO can be compared. This is possible because the LO's instability will be common to both channels, if the two-channel mixing and measurements occur at precisely the same point in time. (This constraint means that the phase difference between sources should be constant over the time of measurement. Adjustment of the phase difference is required to obtain the lowest noise floor. See Delay



The most common application of the technique is to compare primary frequency standards. See figure 19. But there are other applications that benefit as well. Consider the case of a "black box" two-port device that does not alter the input frequency but may add phase noise or jitter, see figure 20. The nominal phase through the device is constant with time. This device could be an amplifier, a synthesizer, or other circuit that basically meets the requirements of the same frequency and fixed phase offset. In frequency domain phase noise measurements, this is sometimes called residual noise measurement. The dual mixer technique allows time domain Allan variance analysis of the same information.

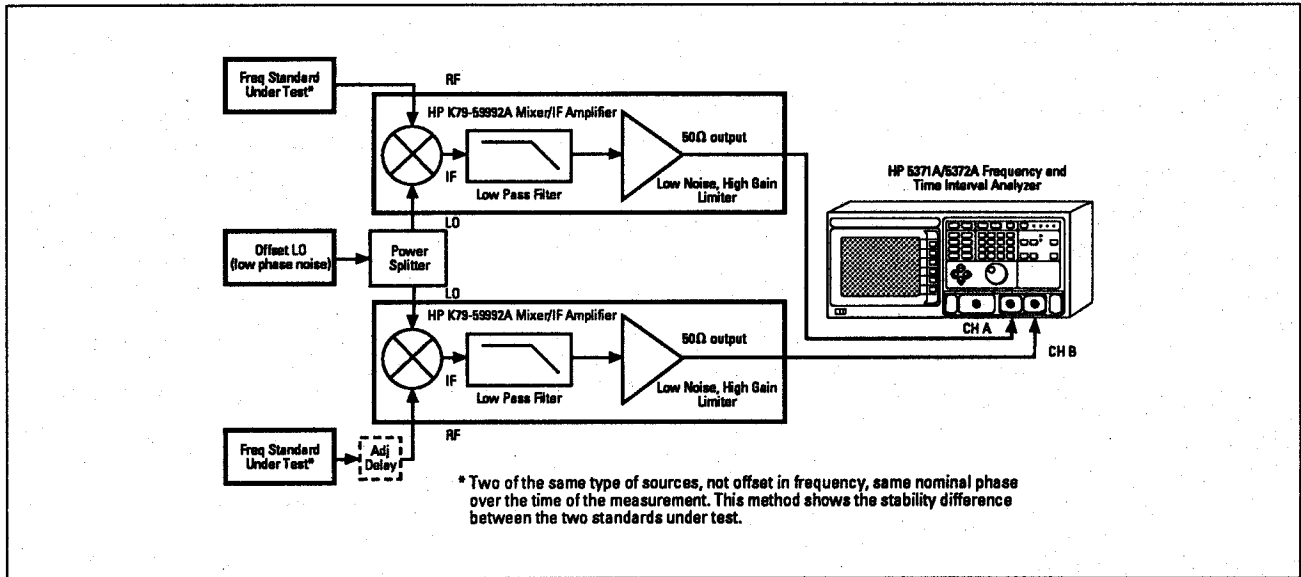

Figure 19. Using the dual mixer method to compare two primary frequency standards.

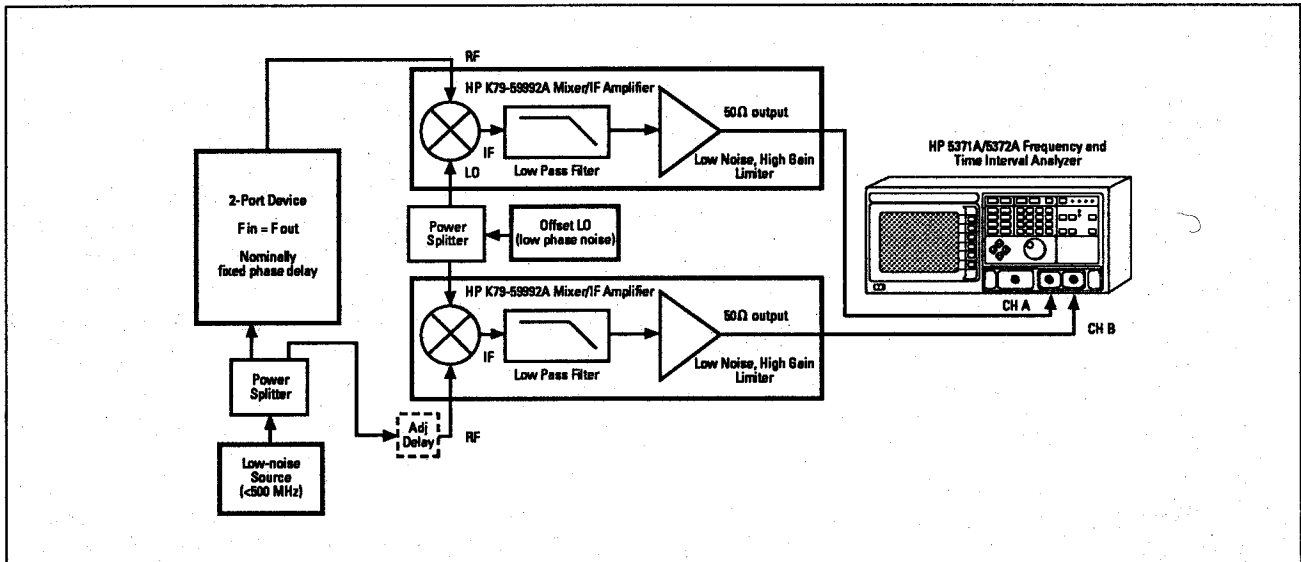

Figure 20. Making residual noise measurements of a two-port DUT using the dual mixer method.

### Local Oscillator Selection for Dual Mixer Applications

Even though the LO does not need to be as stable as the DUTs in the dual mixer setup, a low-noise source is recommended to get the best noise floor performance. Crystal oscillators with low white phase noise and low additive noise are ideal. However, satisfactory results can be obtained with other types of sources, such as signal generators and synthesizers, if the the delay between channels is adjusted carefully. (See Delay Adjustment Procedure below).

In recent tests of the K79 noise floor, three LOs were used to test the sensitivity of the dual mixer system noise floor to the LO; an offset crystal oscillator, an HP 3325A and an HP 8640B. All three were also tested in a single mixer setup using a crystal oscillator as a reference to determine their root-Allan variance performance. Their root-Allan variance plots are shown below in figure 21. Note the difference in the types of noise processes and the levels. The HP 3325A has high white phase noise, while the HP 8640B's plot is almost flat with tau, indicating flicker FM noise at a high level.

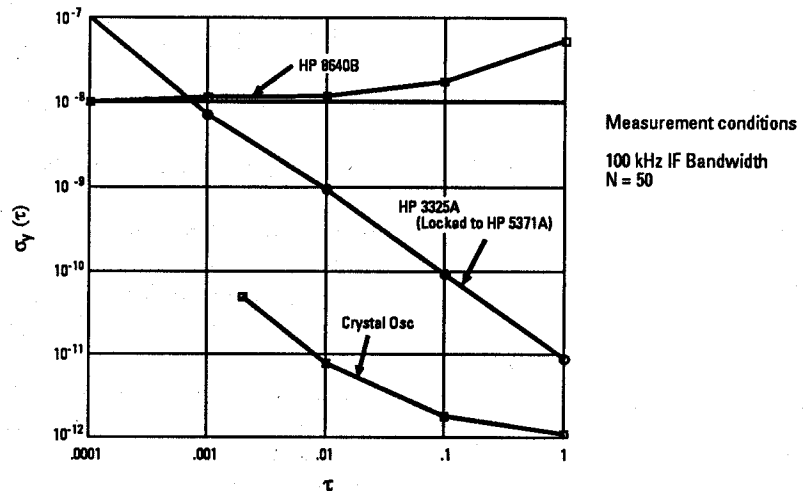

Figure 21. Frequency stability results for three sources that could be used as an LO in the dual mixer method.

Since in actual practice the instabilities of the LO will not cancel completely, the crystal oscillator is by far the lowest noise and, therefore, the best choice. If the ultimate noise floor is not required, then other sources can be used. Setting the delay between the two measurement channels is most important. As the delay is increased from the ideal value of 0 degrees, the two channels will no longer be measured at the same time, causing LO noise to be uncorrelated and raising the noise floor. The noisier the LO, the more pronounced this effect becomes. Some examples are shown in the next section, Delay Adjustment Procedure.

### Delay Adjustment Procedure

Since delay affects the noise floor in the dual mixer method, setting the delay is the first thing to do after the IF is selected. Start with the noise floor testing configuration, see figure 11, on page 18. The goal is to keep the differential delay to a minimum. The exact location(s) of the delay element(s) depends upon the configuration

used and the device under test. All signal paths should start out being the same electrical length. Cables from the splitters to the mixers should be identical. This path is at the RF frequency and a short length difference will cause a large amount of phase difference, though being a small time difference. (At 1.5 ns delay/foot of 50 ohm coax, one inch of difference is about 0.12 ns, or 0.4 degrees of phase at 10 MHz).

Since phase remains constant through the mixing process, the 1 inch length difference at 10 MHz will add .4 degrees of phase delay at the IF. If the IF is 500 Hz, .4 degrees is 2.2  $\mu$ s. In order to reach the lowest noise floor, delays at the analyzer inputs should be set to values ranging from 50 ns to 1  $\mu$ s. This delay is most easily adjusted by making small length changes in one of the DUT cables feeding the RF mixer port on one K79 unit. To monitor the delay, use the HP 5371A/5372A analyzer:

1. Set up to measure  $\pm$  Time Interval A  $\rightarrow$  B repeating one measurement.
2. Set the Input menu for Manual Triggering at 0 volts.
3. Turn off all Math and Statistics.
4. Monitor the Numeric Results screen to see the delay values.

Next adjust the delay to be >10 ns (CH A  $\rightarrow$  B). Values <1  $\mu$ s have resulted in satisfactory noise floors in our testing of the K79 setup. If any jitter or drift is present that would drop the delay below 10 ns, then add more delay as a guardband.

With the delay set, the noise floor of the system can be measured. After the noise floor is verified, the DUT phase difference should be adjusted in the same way. The nominal difference desired at the mixer inputs is 0 degrees, with fine adjustment to tune the IF delay to the same value that was used to measure the noise floor.

The reason that the delay must be >10 ns is that when the HP 5371A/5372A is measuring frequency on both channels, the Channel B trigger must occur >10 ns after Channel A, or the frequency on Channel B will be measured starting on the following Channel B trigger event. This means there will be up to a one period delay in the measurement. This one period delay will raise the noise floor drastically for lower stability LOs.

In fact, one way to get about a 360 degree difference in the Channel A and B measurements is to reverse the inputs to get a negative delay. This method was used to test the LOs shown below.

The data below (figures 22, 23, and 24) shows the effect of the delay on the noise floor for three types of LO sources. Note that if the crystal LO source is used, the delay is not that critical. In this case, one could have non-constant phase between DUTs and not sacrifice much of the noise floor.

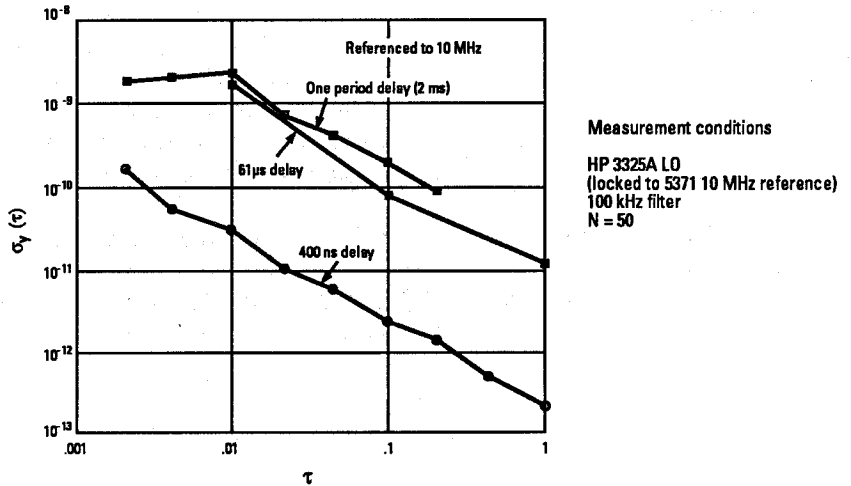

Figure 22. Dual mixer noise floor as a function of delay. When an HP 3325A is used as an LO for the dual mixer setup, delay adjustments are very important to canceling the LO noise. The IF delay is measured with the HP 5371A/5372A in  $\pm$  Time Interval mode.

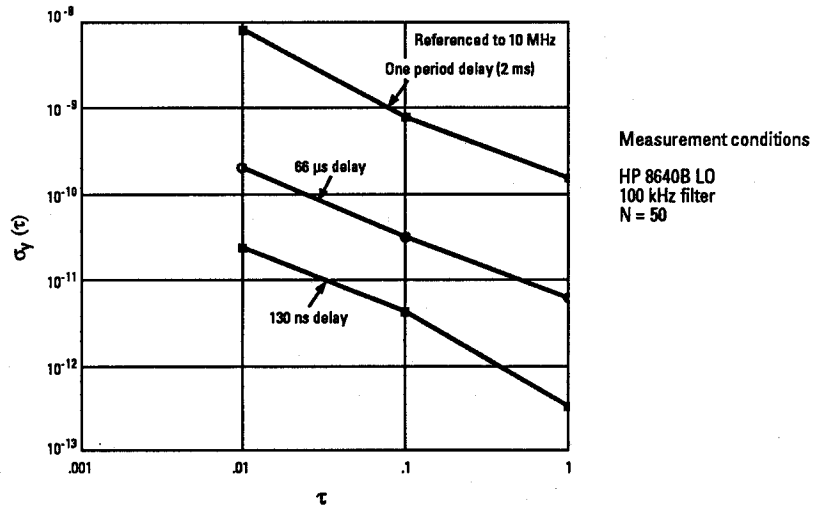

Figure 23. Using an HP 8640B as the LO, small delays may allow noise floors low enough for some DUTs, but high stability DUTs require high stability LO sources, see figure 24.

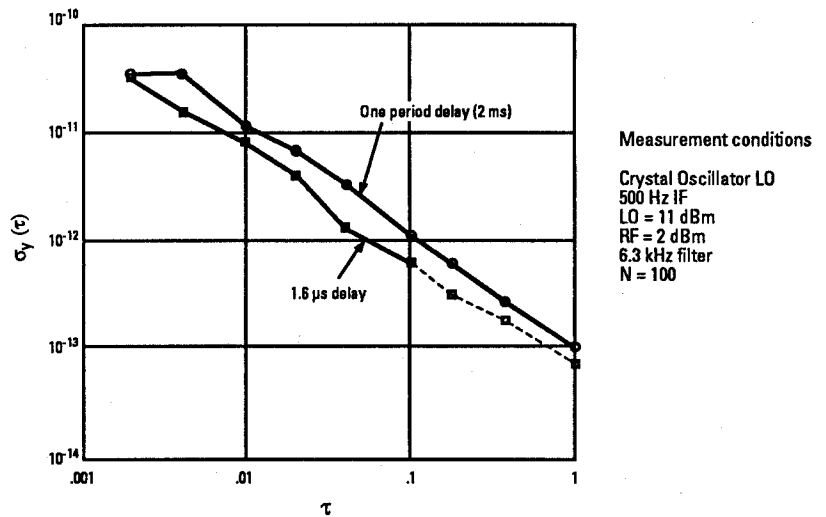

Figure 24. With a low noise, high stability crystal LO, delay adjustments are not as critical and the lowest noise floor is achievable.

## **Summary**

**This note discusses various topics relating to time domain frequency stability measurements using the HP K79-59992A Mixer/IF Amplifier with the HP 5371A/5372A Frequency and Time Interval Analyzer. Measurements of the system noise floor under different conditions are shown to aid the user in setting up similar measurements, and can be used as a point of comparison.**

**For more information about frequency stability analysis and measurement, a short list of references is included at the back of this note. This list contains extensive bibliographies for further study.**

## Appendix A

### K79-59992A Mixer/IF Amplifier Characteristics

The following table outlines the characteristics of the HP K79-59992A Mixer/IF Amplifier. This is the ideal mixer to use with the HP 5371A/5372A Frequency and Time Interval Analyzer for frequency stability applications:

Table 1

| <b>Mixer/IF Amplifier Function</b><br>Performs Input signal conditioning and creates IF signal for the HP 5371A/5372A Frequency and Time Interval Analyzer |             |             |                        |                        |                   |                  |
|--|-------------|-------------|------------------------|------------------------|-------------------|------------------|
| <b>Inputs</b>  | <b>Band</b> | <b>Port</b> | <b>Frequency Range</b> | <b>Operating Level</b> | <b>VSWR (TYP)</b> | <b>Connector</b> |
|  | RF          | RF          | 0.5 to 500 MHz         | -20 to -5 dB LO        | <2.0:1            | BNC              |
|  |             | LO          | 0.5 to 500 MHz         | +5 to +10 dBm          | <1.5:1            | BNC              |
| (rear input)   |             | EXT IF      | 10 Hz to 100 kHz       | -15 to 0 dBm           | <1.5:1            | BNC              |
| Input levels should be kept below +15 dBm/32 mW or damage to mixers may occur.   |             |             |                        |                        |                   |                  |
| <b>IF OUTPUT</b>   |             |             |                        |                        |                   |                  |
| Waveform: Square wave output   |             |             |                        |                        |                   |                  |
| Frequency: 10 Hz to 100 kHz  |             |             |                        |                        |                   |                  |
| Level: 200 to 300 mV peak-to-peak centered about zero volts  |             |             |                        |                        |                   |                  |
| Impedance: 50 $\Omega$ , nominal   |             |             |                        |                        |                   |                  |
| Rise Time: <20 ns  |             |             |                        |                        |                   |                  |
| Fall Time: <20 ns  |             |             |                        |                        |                   |                  |
| EXT FILTER INPUT/OUTPUT: Rear panel connectors provide for the insertion of an external IF filter.   |             |             |                        |                        |                   |                  |
| Operating Temperature: 0°C to 50°C   |             |             |                        |                        |                   |                  |
| Power Requirements: 100/120/200/240 (+5% -10%) 48-66 Hz, 5 VA.   |             |             |                        |                        |                   |                  |

## Appendix B

### Conversion Equations

The following table shows conversion equations that relate Allan variance to phase spectral density. Recall that the Single-sided Phase Noise value ( $\mathcal{L}(f)$ ) is 1/2 the Phase Spectral Density value ( $\mathcal{L}(f) = 1/2 S_{\phi}(f)$ ). Note that these equations relate Allan variance, not root-Allan variance, and that the type of noise must be known.

| $S_y(f) = H_{\alpha} f^{\alpha}$<br>$\alpha =$ | $S_y(f) = a \sigma_y^2(t)$<br>$a =$                        | $\sigma_y^2(t) = b S_{\phi}(f)$<br>$b =$                         |
|--|--|--|
| 2<br>(white phase)                             | $\frac{(2\pi)^2 \tau^2 f^2}{3 f_h}$                        | $\frac{3 f_h}{(2\pi)^2 \tau^2 v_0^2}$                            |
| 1<br>(flicker noise)                           | $\frac{(2\pi)^2 \tau^2 f^2}{1.038 + 3 \ln(\omega_h \tau)}$ | $\frac{[1.038 + 3 \ln(\omega_h \tau)] f}{(2\pi)^2 \tau^2 v_0^2}$ |
| 0<br>(white frequency)                         | $2 \tau$   | $\frac{f^2}{2 \tau v_0^2}$                                       |
| -1<br>(flicker frequency)                      | $\frac{1}{2 \ln(2) \cdot f}$                               | $\frac{2 \ln(2) \cdot f^3}{v_0^2}$                               |
| -2<br>(random walk frequency)                  | $\frac{6}{(2\pi)^2 \tau f^2}$                              | $\frac{(2\pi)^2 \tau f^4}{6 v_0^2}$                              |

Conversion table from time domain to frequency domain and from frequency domain to time domain for common kinds of integer power law spectral densities;  $f_h (= \omega_h/2\pi)$  is the measurement system bandwidth. Measurement response should be within 3 dB from dc to  $f_h$  (3 dB down high-frequency cutoff is at  $f_h$ ).

Where:

- $\tau$  = tau
- $f$  = Fourier frequency
- $v_0$  = DUT's frequency
- $f_h$  = Measurement bandwidth

For more information and example conversions, see reference #1.

---

## References

---

The following references may be useful:

1. D.A. Howe, D.W. Allan, and J.A. Barnes, *Properties of Signal Sources and Measurement Methods* Proc. 35th Ann. Freq. Control Symposium, USAERADCOM, Ft. Monmouth, NJ 07703. May 1981
2. D.W. Allan, *The Measurement of Frequency and Frequency Stability of Precision Oscillators*, NBS Tech. Note 669 (1975); Proc. 6th PTTI Planning Meeting, 109 (1975).
3. Proceedings of the IEEE. Special issue on frequency stability, vol. 54, February 1966.
4. Proceedings of the IEEE. Special issue on time and frequency, vol. 60, no. 5, May 1972.
5. Proceedings of the IEEE-NASA Symposium on the Definition and Measurement of Short-Term Frequency Stability at Goddard Space Flight Center, Greenbelt, MD, November 23-24, 1964. Prepared by Goddard Space Flight Center (Scientific and Technical Information Division, National Aeronautics and Space Administration, Washington, DC 1965). Copies available for \$1.75 from the US Government Printing Office, Washington, DC 20402.
6. J.A. Barnes, A.R. Chi, L.S. Cutler, et al., *Characterization of Frequency Stability*, IEEE Trans. on Instrum. and Meas. IM-20, no. 2, pp. 105-120 (May 1971). Prepared by the Subcommittee on Frequency Stability of the Institute of Electrical and Electronics Engineers.
7. *Time and Frequency: Theory and Fundamentals*, Byron E. Blair, Editor, NBS Monograph 140, May 1974.
8. P. Kartaschoff, *Frequency and Time*, London, England: Academic Press, 1978.
9. G.M.R. Winkler, *Timekeeping and Its Application*, *Advances in Electronics and Electron Physics*, Vol. 44, New York: Academic Press, 1977.
10. E.A. Gerber, *Precision Frequency Control and Selection, A Bibliography*, Proc. 33rd Annual Symposium on Frequency Control, pp. 569-728, 1979. Available from Electronics Industries Association, 2001 Eye St. NW, Washington, DC 20006.



11. J. Rutman, *Characterization of Phase and Frequency Instabilities in Precision Frequency Sources: Fifteen Years of Progress*, Proc. IEEE, vol. 66, no. 9, September 1978, pp. 1048-1075.
12. J.A. Barnes, *A Review of Methods of Analyzing Frequency Stability*, Proc. 9th Annual Precise Time and Time Interval (PTTI) Applications and Planning Meeting, Nov. 1977, pp. 61084.
13. D.B. Leeson, *A Simple Model of Feedback Oscillator Noise Spectrum*, Proc. IEEE L., vol. 54, pp. 329-330, February 1966.
14. P. Lesage and C. Audoin, *A Time Domain Method For Measurement of the Spectral Density of Frequency Fluctuations at Low Fourier Frequencies*, Proc. 29th Annual Symposium on Frequency Control, 1975, pp. 394-403.
15. J. Shoaf, *Specification and Measurement of Frequency Stability*, NBS Internal Report 74-396, November 1974.
16. G.M.R. Winkler, *A Brief Review of Frequency Stability Measures*, Proc. 8th Annual Precise Time and Time Interval (PTTI) Applications and Planning Meeting, Nov. 1976, pp. 489-527.
17. R. Burgoon, *The HP Standard*, July 1985, Page 7.
18. Proceedings of the Annual Symposium on Frequency Control. Prepared by the US Army Electronics Command, Fort Monmouth, NJ. Copies available from:
  - 1977 and earlier, 1982  
National Technical Information Service  
5285 Port Royal Road, Sills Building  
Springfield, VA 22161
  - 1978 - 1981  
Electronic Industries Association  
c/o Frequency Control Symposium  
2001 Eye Street, Washington, DC 20006
  - 1983 - Present  
Institute of Electrical and Electronic Engineers  
445 Hoes Lane  
Piscataway, NJ 08854
19. R. Burgoon and M.C. Fischer, *Conversion Between Time and Frequency Domain of Intersection Points of Scopes of Various Noise Processes*. Proc. 32nd Annual Symposium on Frequency Control, 1978, pp. 514-519.

**For more information, call you local HP sales office listed in your telephone directory or an HP regional office listed below for the location of your nearest sales office.**

**United States:**

Hewlett-Packard Company  
4 Choke Cherry Road  
Rockville, MD 20850  
(301) 670-4300

Hewlett-Packard Company  
5201 Tollview Drive  
Rolling Meadows, IL 60008  
(312) 255-9800

Hewlett-Packard Company  
5261 Lankershim Blvd.  
No. Hollywood, CA 91601  
(818) 505-5600

Hewlett-Packard Company  
2015 South Park Place  
Atlanta, GA 30339  
(404) 955-1500

**Canada:**

Hewlett-Packard Ltd.  
6877 Goreway Drive  
Mississauga, Ontario L4V 1MB  
(416) 678-9430

**Japan:**

Yokogawa-Hewlett-Packard Ltd.  
15-7, Nishi Shinjuku 4 Chome  
Shinjuku-ku  
Tokyo 160, Japan  
(03) 5371 1351

**Latin America:**

Hewlett-Packard  
Latin American Region Headquarters  
Monte Pelvoux No. 111  
Lomas de Chapultepec  
11000 Mexico, D.F. Mexico  
(525) 202-0155

**Australia/New Zealand:**

Hewlett-Packard Australia Ltd.  
31-41 Joseph Street  
Blackburn, Victoria 3130  
Melbourne, Australia  
(03) 895-2895

**Far East:**

Hewlett-Packard Asia Ltd.  
22/F Bond Centre  
West Tower  
89 Queensway  
Central, Hong Kong  
(5) 8487777

**In Europe, please call your local HP sales office or representative:**

**Austria, COMECON-countries and Yugoslavia:**  
(0222) 2500 0

**Belgium and Luxembourg:**  
(02) 761 34 00

**Denmark:**  
(02) 81 66 40

**Finland:**  
(0) 88 721

**France:**  
(1) 60 77 42 52

**Germany:**  
(06172) 16 0

**Greece:**  
(01) 68 28 11

**Iceland:**  
(01) 671 000

**Ireland:**  
(01) 88 33 99

**Italy:**  
(02) 92 36 91

**Netherlands:**  
(020) 547 6669

**Norway:**  
(02) 24 60 90

**Spain:**  
900 123 123

**Sweden:**  
(08) 750 20 00

**Switzerland:**  
(057) 31 21 11 (Head Office)  
(022) 780 41 11 (Suisse Romande)  
(046) 05 15 05 (Customer Information Center)

**U.K.:**  
(0734) 777 828

**Middle East and Africa:**  
Geneva-Switzerland  
41/22 780 7111

**European Headquarters**  
Hewlett-Packard S.A.  
150, Route du Nant d'Avril  
1217 Meyrin 2  
Geneva--Switzerland  
41/22 780 8111

Prices and Data Subject to Change  
January, 1990

Copyright © 1989  
Hewlett-Packard Co.