

Simulating Sensor Signals

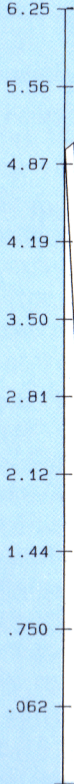

Calibrating and testing an IR Detecting System
with the HP 8175A

Application Note AN 341-2

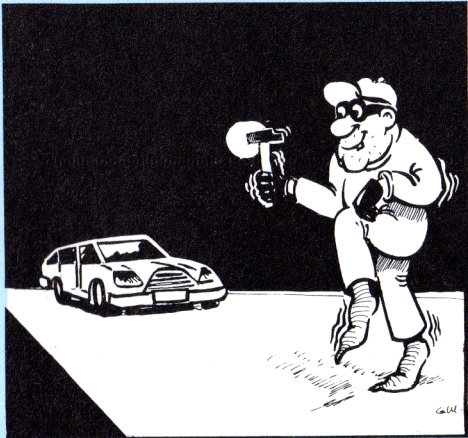

Introduction

Control tasks in a real-life environment are dominated by analog signals. These real-life signals are detected using a large variety of sensors, which change the physical signal into an electrical one. Examples of such sensors are infrared, inductive and pressure sensors. The most flexible and effective way to analyze, evaluate and control real-life signals is to use digital signal processing.

This Application Note describes an example of how to calibrate, optimize and sensitize an Infrared Detecting System, using the HP 8175A Digital/Analog Signal Generator. This is an example which relates to the expanding field of sensor systems. The example can be described, due to the kind permission of the F+G Megamos Company, a West German manufacturer of detecting systems and alarm devices.

Description of the Infrared (IR) Detecting System

The Infrared Detecting System (Fig 1) is essentially composed of four functional parts:

- 1) The infrared transmitter and receiver unit
- 2) The transmitter driving circuit
- 3) The filter and amplifier circuit
- 4) The microprocessor module with the A/D converter

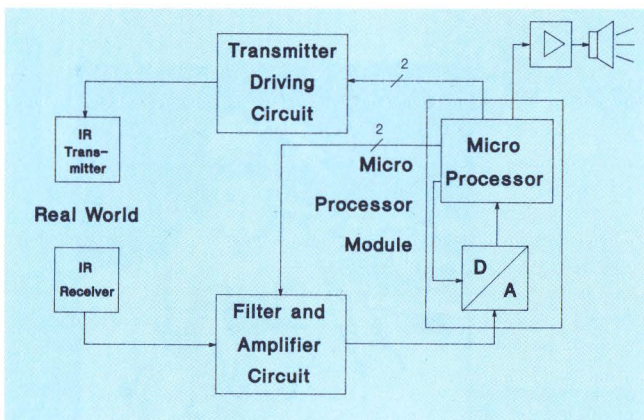

Fig 1: Blockdiagram of the IR Detecting System

The microprocessor's task is to control the whole detecting system and to analyze the received signals. The microprocessor evaluates the received signal and reacts when events occur, such as the entrance of persons into or the removal of parts from the safety area. The microprocessor should not react to general environmental influences such as sunlight flashes or IR interference transmission.

During the development of the infrared detecting system it was necessary to simulate and vary control lines of the microprocessor and the IR receiver output signals of external events for the calibration and optimization of the different parts of the IR Detecting System.

Using the HP 8175A helps to solve the simulation problems

At first the HP 8175A is used as a digital signal-generator, in place of the microprocessor, in order to stimulate the transmitter, so that a stabilized IR environment is created (Fig 2). The digital signals, simulated by the HP 8175A, are then eventually provided by the microprocessor module in the IR Detecting System.

The HP 8175A is then used as an analog signal-generator (Fig 7), in place of the IR receiver. Stored real-life signals are sent by the controller to the HP 8175A, which then is used to modify and generate analog signals.

In this way, the IR Detecting System can be reliably calibrated and optimized, using only one stimulus instrument.

For the whole test set-up only a controller (e.g.: HP Series 200/300) including software, a digitizing oscilloscope (e.g.: HP Series 54100/200) and the HP 8175A Digital/Analog Signal Generator are required.

Acquisition of the real-life signals

For the acquisition of the real-life signal (Fig 2), the HP 8175A first simulates the digital control lines S_1 to S_5 (Fig 3) of the microprocessor module, which drives the transmitter driving circuit, thus the IR transmitter. It controls the filter and amplifier circuit, as well as the A/D converter. The time relationships between the 5 control lines are very different, but that is no problem for the HP 8175A. The HP 8175A generates up to 24 parallel-signals. With the help of the individual-pattern duration, which allows you to program the duration of each individual pattern from 20 ns up to 10 sec and the virtual memory expansion featuring the segmentation of the physical memory (up to 256 segments can be defined), the control lines are comfortable to program.

By optimizing the times t_1 to t_5 of the digital control lines, it was possible to obtain a low-noise signal at the output of the filter and amplifier circuit. The signals received at the IR receiver are recorded with the digitizing oscilloscope at the output of the filter and amplifier circuit.

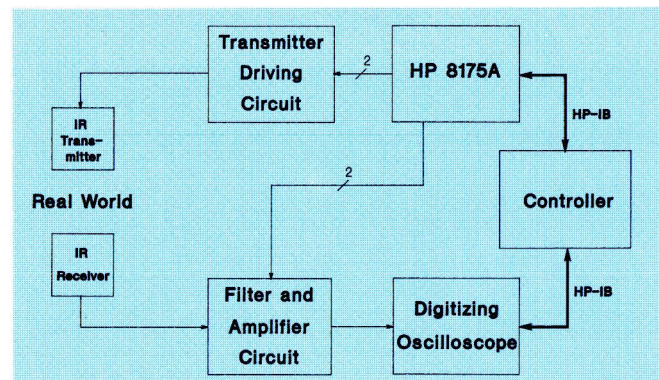

Fig 2: Blockdiagram of the Signal Acquisition Set-up

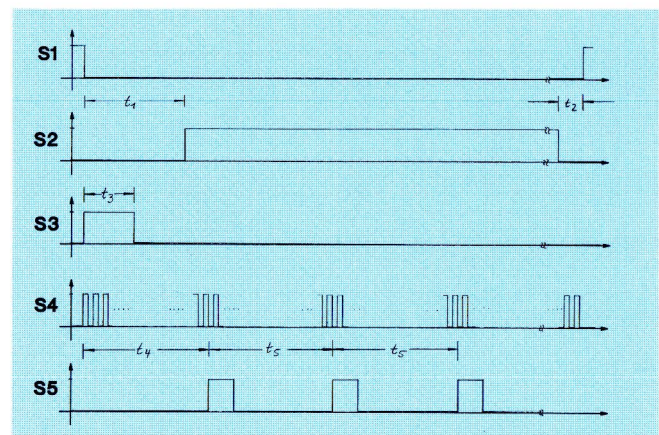

Fig 3: Microprocessor Control Line Signals

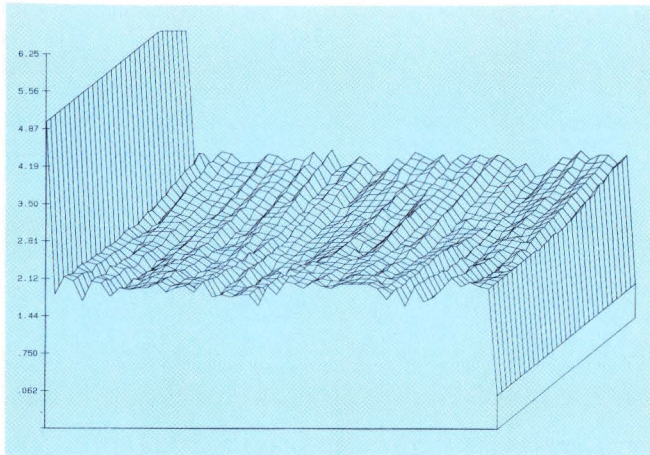

Fig 4: Normal State

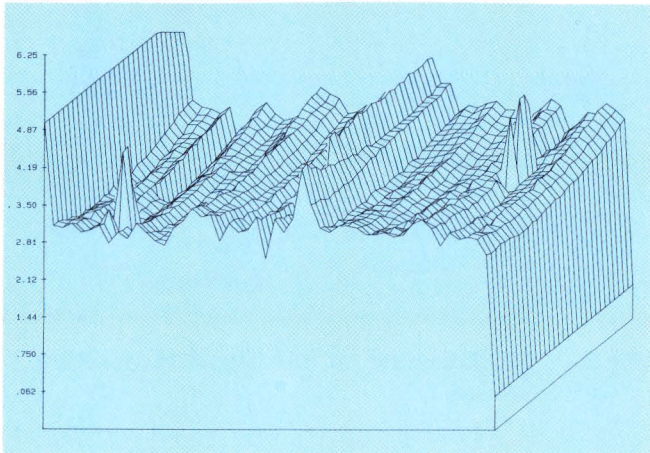

Fig 5: Environmental Influence

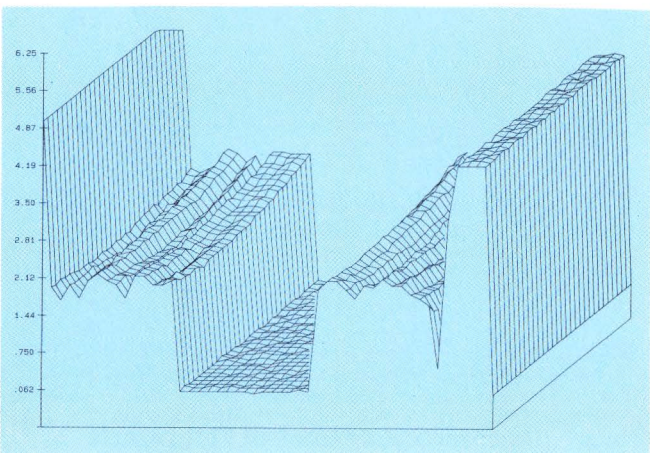

Fig 6: Alarm Event

Gathering the analog test-signals

During the signal acquisition of different detectable events, several snapshots are taken for a measurement of up to 10 seconds and stored in the controller. The program, running on the controller joins the snapshots of the measured events together, so that it can plot them as a 3D-diagram. Every 100 ms (x-axis) a snapshot for about 4 ms (z-axis) is taken of the IR level (y-axis) of the controlled safety-area under a certain event.

The 3D-diagrams are helpful for the design engineer to obtain the overview of the characteristic for a definite event. For example, the normal state (Fig 4) or if environmental influences (Fig 5) or an alarm event (Fig 6) occurs. The advantages are:

- Events which are difficult to produce or require the destruction of a definite part in the safety area, have to be captured only once, so time and money can be saved, because it is now easy to generate and vary the signal with the HP 8175A.
- The testing of the detecting system can be done in the design lab, there is no need anymore to go to the real safety-area.
- The design engineer can mix different events in one signal.
- Parallel development of the different parts of the system is possible.
- The signals can also be used in the production for the quality test procedure.

HP 8175A generates the analog test-signals

The single-snapshot signals of the different events recorded with the digitizing oscilloscope are stored in the controller. They can be downloaded to the HP 8175A via HP-IB (Fig 7) using a particular program.

The HP 8175A can generate up to two parallel analog-signals. Each channel possesses a physical memory depth of 1024 datapoints. Thus, for example, if 100 datapoints are used for an arbitrary signal, it is possible to program 10 different signals in the physical memory.

Also available for a high signal-flexibility is the virtual-memory expansion and the individual-datapoint duration.

With the signals now available in the HP 8175A (Fig 8) it is possible to test, optimize and sensitize the filter and amplifier circuit, and the microprocessor using the A/D converter and the analyzing software.

The design engineer can add noise to the signal, with the calculator mode of the HP 8175A, and insert glitches and peaks with the comprehensive editing mode.

The HP 8175A allows you to vary the high- and low-level of the signal in a ± 8 V window into 50Ω , an offset is separately programmable. Thus different environment influences or other events can be simulated, and then applied continuously to the test module.

With its interaction capability the HP 8175A can react on up to 8 bit wide trigger events to branch to pre-defined signals and loop them as required. If it is necessary, the HP 8175A can generate up to 8-bit-wide flag words. Another feature is the ability to store up to 6-channel data-set ups internally, or unlimited signals externally, thus allowing quick signal-changes.

In this way the microprocessor module can be optimized, so only an alarm will be given, if the definite-event characteristic occurs.

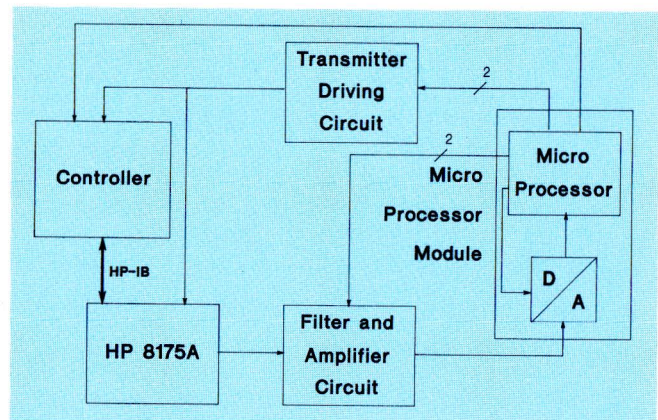

Fig 7: Blockdiagram of the Test Set-up of the Microprocessor Module

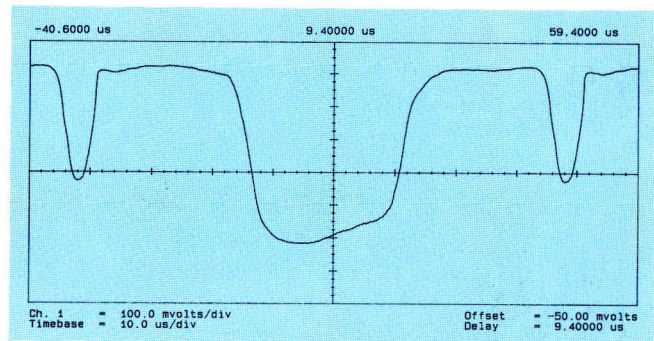

Fig 8: Analog Signal created by the HP 8175A, plotted from a HP 54110D Digitizing Scope

HP 8175A tests the parts in the production area, not only in R&D

The comprehensive feature set of the HP 8175A are not only helpful in the R&D labs, but also in production. It is used here to gain the throughput of the manufactured systems. The HP 8175A is a suitable instrument for ATE systems due to its full-programmability via the HP-IB bus. So time and money can be saved when testing with the HP 8175A. The reliability of the tested systems is increased because real-life signals can be used for the test and calibration of the produced systems (Fig 9).

Conclusion

As the example shows, there is a strong demand in the sensoric area for a generator which delivers both digital and analog signals, as analog signals are found in the natural environment, but today the signal processing is done by digital signal-processing. The HP 8175A is an instrument which meets most of the requirements of many application cases in the sensoric area.

Outlook

Another field which demands arbitrary waveforms is the mechanical and automotive field. Option 002 of the HP 8175A offers two analog outputs. If there is only one analog signal required, 14 digital signal outputs are left over. The analog and digital channels are synchronously generated. This is an expanding capability of the HP 8175A and fits applications in the previously mentioned fields, as you can simulate signals, such as real-life signals, and driving and control signals for electromechanical devices, etc.

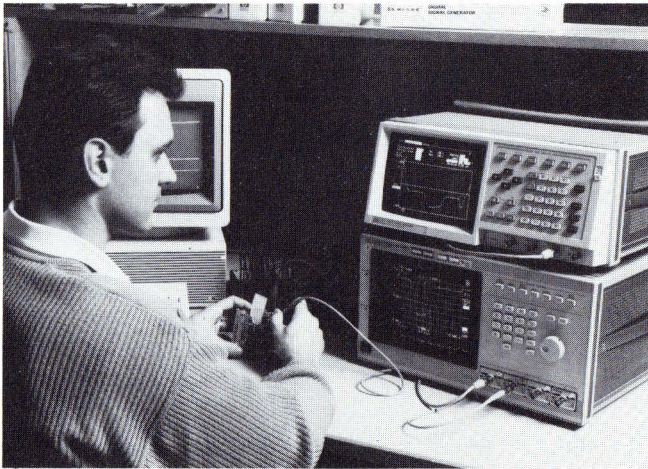

Fig 9: Testing the Microprocessor Module

Advantages

when the HP 8175A is used

The HP 8175A Digital/Analog Signal Generator's ability to generate digital, analog and mixed signals is helpful to reduce the design cycle of the various circuits of the IR Detecting System. The HP 8175A shortens the calibration and optimization cycle of the filter and the micro-processor module using the analyzing software. It helps to save time and money, because single-shot signals, once recorded with a digitizing oscilloscope are continuously repeatable with the HP 8175A. The reliability of the entire system is increased too, because it is now possible to vary the former-recorded signals to optimize and calibrate the system so that it reacts properly.

ADDITIONAL LITERATURE

	Lit No:
Technical Data HP 8175A	5952-9595
Application Note AN 341-1 Testing a complex VLSI IC	5952-9572
Product Note Wavemaker	5952-9604
Wavemaker Software Pac User's Guide	5952-9605
Product Note Coder	5952-9606
Coding Software Pac User's Guide	5952-9607
Product Note Learn String	5952-9608
Learn String User's Guide	5952-9609
Product Note Link	5952-9622
Link Software Pac User's Guide	5952-9623
Product Note Arbitrary Test Signals	5952-9626
ARB Waveform Library Disc User's Guide	5952-9627



For more information, call your local HP sales office listed in the telephone directory white pages. Ask for the Electronic Instruments Department, or write to Hewlett-Packard; U.S.A.-P.O.Box 10301, Palo Alto, CA 94303-0890. **Europe/Middle East/Africa**-Central Mailing Department, P.O.Box 529, 1180 AM Amstelveen, the Netherlands. **Canada**-6877 Goreway Drive, Mississauga, L4V 1M8, Ontario. **Japan**-Yokogawa-Hewlett-Packard Ltd., 3-29-21, Taikaido-Higashi, Suginami-ku Tokyo 168. **Elsewhere** in the world, write to Hewlett-Packard Intercontinental, 3495 Deer Creek Road, Palo Alto, CA 94304.