

5345 ELECTRONIC COUNTER

HEWLETT  PACKARD

MEASURING DUAL VCO TRACKING ERROR

Many applications for voltage controlled oscillators require that two VCO's track each other. Laborious manual tests are often made to ensure that the tracking error does not exceed set limits over a specific range of control voltage. Application note 174-4 discusses the use of the HP 5345 Electronic Counter in a calculator based HP Interface Bus system to automatically measure and plot the tracking error between two voltage controlled oscillators. (A similar program is actually used by production personnel at the Santa Clara Division of Hewlett-Packard to test the tracking error between two VCO's used in the 5340 Microwave Counter.) In a fraction of the time required to perform the measurements and computations manually, the described system measures and plots the transfer characteristics of the two VCO's and the corresponding tracking error. Use of the HP Interface Bus ensures that the instruments need not be dedicated to a particular configuration (as in the case of hard-wired systems). The bus allows instruments to be quickly and easily reconfigured to meet the changing requirements of production, R & D, or quality control.

APPLICATION
NOTE 174-4



MEASUREMENT SET-UP

The measurement system consists of the 5345A Electronic Counter (Opt. 011), the 9820A Calculator (Opt. 001 Extended Memory), the ASCII Bus Interface Card and PCII ROM (both included in 10593A), 11221A Math ROM, 11220A PCI ROM, 9862A Calculator Plotter (Opt. 20), HP 59307A VHF Switch, and 59303A Digital to Analog converter (four HP 59304A Numeric Displays are optional). The instruments are connected to the calculator as shown in Figure 1.

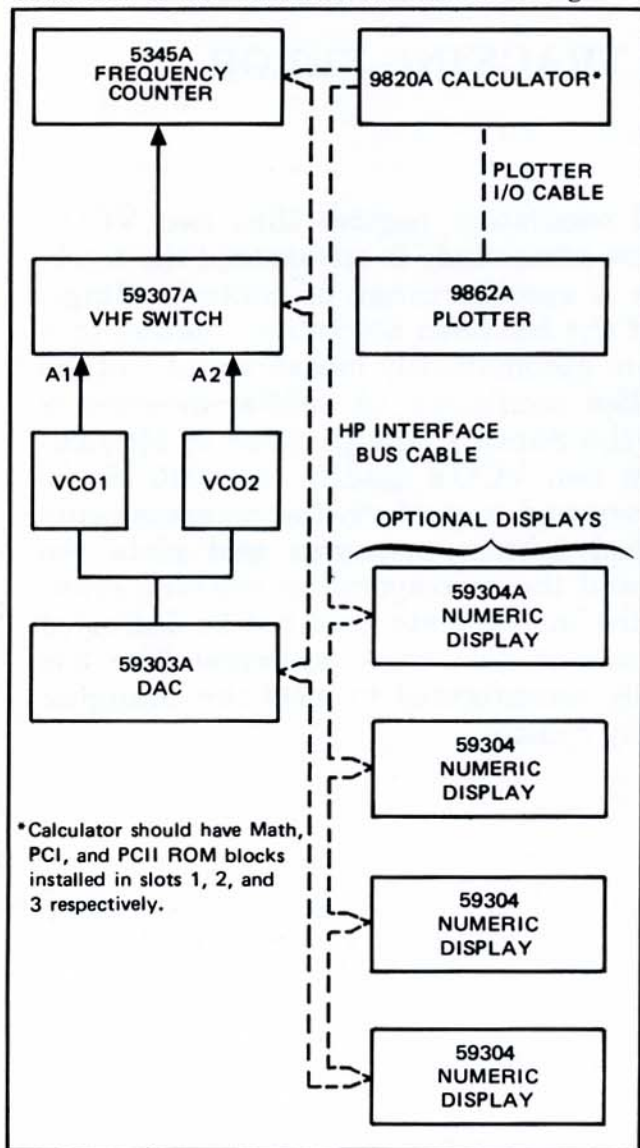

Figure 1

Since the 9820 calculator remotely controls all front panel controls of the D to A converter and frequency counter, there is no need to set these controls to any particular positions. The calculator is electrically interfaced to the 59303 DAC, the 5345A Frequency Counter, and 59307 VHF Switch by connecting ASCII interface cables (10631 A, B, or C) from the rear panel mounted ASCII bus interface card of the calculator to the rear plugs of the DAC, the frequency counter, and the VHF switch. Connect the 9862A plotter I/O card into one of the three remaining rear

panel slots of the 9820 Calculator. (The ASCII interface card is plugged into the fourth slot—it doesn't matter which slots are used.)

Set the Talk/Listen addresses on the DAC, the frequency counter, the switch, and the numeric displays (optional) as specified in the following table:

Table 1

	Talk/Listen Addresses	Mode Switch	A5	A4	A3	A2	A1
59303A DAC	/=(program) /<(data)	addressable	1	1	1	0	**
5345A Counter	J/*	addressable	0	1	0	1	**
59307A Switch	/>	addressable	1	1	1	1	0
59304A Display (displays freq. - VCO1)	/3	addressable	1	0	0	1	1
59304A Display (displays freq. - VCO2)	/2	addressable	1	0	0	1	0
59304A Display (displays VCO1-VCO2)	/1	addressable	1	0	0	0	1
59304A Display (displays DAC output)	/0	addressable	1	0	0	0	0

** Not used.

These switches are located on the rear panels of the instruments and must be set so as to agree with the Talk/Listen addresses in the program.

OPERATION

To measure the tracking error between the two VCO's, key into the calculator the program provided. The program will request values for the minimum (VMIN) and maximum (VMAX) dc voltages to be applied to the VCO's under test (not to exceed the range of the 59303: -9.99 to +9.99 VOLT dc). The program also requests the voltage step size (in Volts) to be used in going between VMIN and VMAX. After entering a requested parameter through the 9820 keyboard, press RUN PROGRAM.

Under control of the calculator, the DAC presents a voltage to both VCO's. The VHF switch is switched to channel A1 and the frequency of VCO1 is measured by the 5345 counter. This data is output to the plot-

ter. The switch is then switched to channel A2 and the counter measures the frequency of VCO2. The current DAC voltage and the frequency of VCO2 are output to the plotter. The percent tracking error

$$\frac{f_{VCO1} - f_{VCO2} \times 100}{f_{VCO1}}$$

is stored. The DAC

voltage is incremented and the above procedure is repeated until the requested voltage range has been spanned. If a "1" is entered when the program displays "TRACKING? 1 or 0", the stored percent tracking error data as a function of DAC voltage is then plotted. The plot in Figure 2 was generated by this program using two HP 3310A Function Generators as the VCO's.

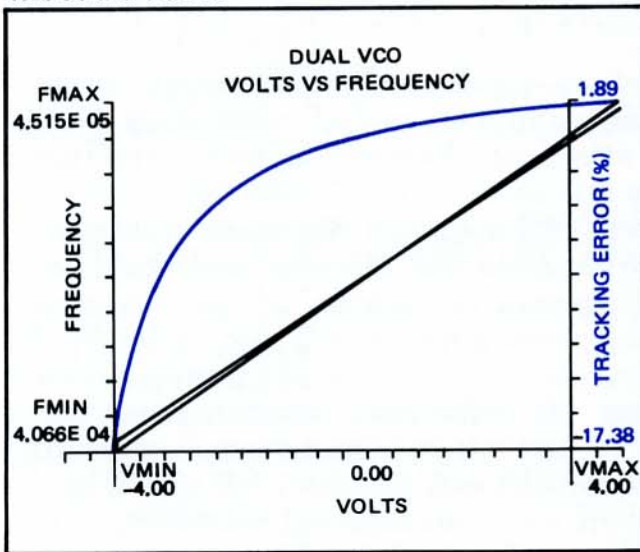

Figure 2

MEASUREMENT CONSIDERATIONS

- Since tracking error is a measure of the difference in frequency of the two VCO's, there must be sufficient resolution in the individual measurements to provide significant digits in the difference. For small tracking errors, the gate time of the counter should be increased so as to provide greater resolution in the individual measurements. The worst case resolution of the counter is 1 part in 10^8 per second of gate time. This program instructs the counter to perform measurements with a 100 msec gate.
- Since the minimum step size possible with the DAC is 10 mV, the STEP SIZE entered into the

program should be an integer multiple of 10 mV so as to avoid errors caused by rounding. (Since the same DAC voltage is presented to both VCO's, DAC error does not affect the computation of tracking error. DAC error does, however, affect the individual VCO transfer characteristic plots as discussed in Application Note 174-1.)

- The maximum number of steps

$$\frac{VMAX - VMIN}{STEP SIZE}$$

is 150 and is limited by the storage capacity of the 9820 calculator.

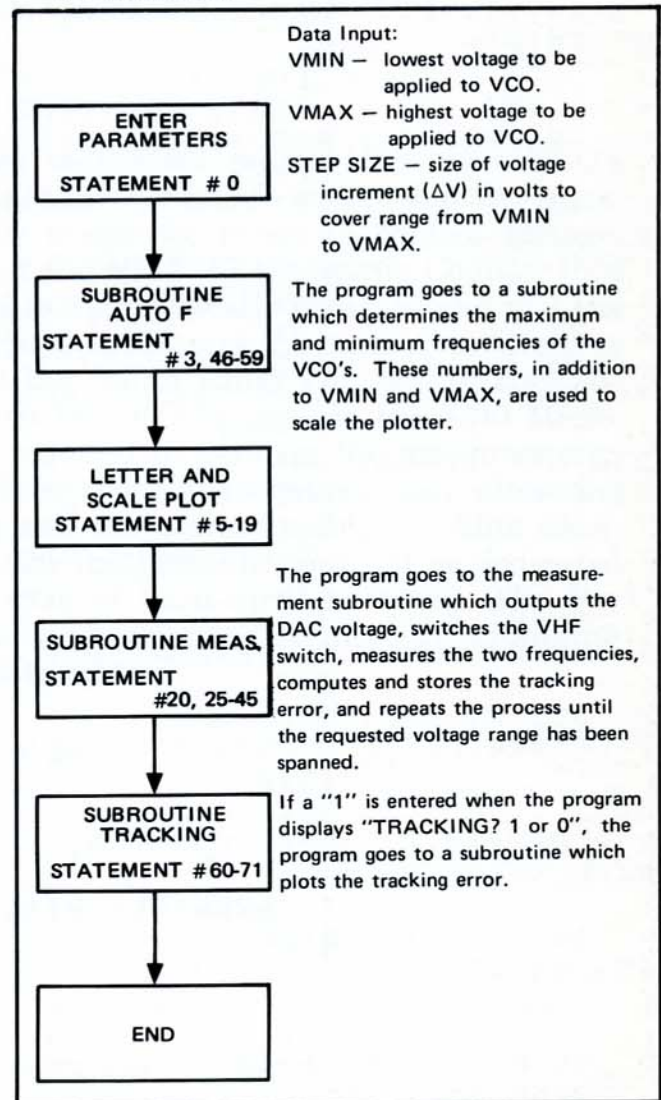

Program Flow Diagram

Program Listing

```

0:          2:          SCL R0-2C,R1,R4-
DSP "DUAL VCO";      (R1-R0)/20→CF      X,R5F
DSP ;DSP ;DSP F      3:          6:
1:          R0→B;GSB "AUTO F      AXE R0,R4,C,(R5-
"LET";ENT "VMIN"      "F      R4)/10F
,R0;ENT "VMAX",R      4:          7:
1;ENT "STEP SIZE      (R5-R4)/10→XF      LTR -.5C+R0,.45(
";AF              5:          R5-R4)+R4,322;
  
```

Program Listing

```

PLT "FREQUENCY"  DSP "END OF PLOT  41:          58:
8:                ";LTR R1,R5F  R6+R9;R7+R10;B+R IF R15<R16;R16+R
LTR -1.25C+R0,.9  24:          11;B+A+BF        5F
7(R5-R4)+R4,211; GT0 0;STP F    42:          59:
PLT "FMAX"  F    25:          FXD 2;DSP B;IF  RET F
9:            "MEAS";CMD "U?*"  FLG 0=1;STP F    60:
FLT 3;LTR -2C+R0 , "I2E9:8I1G?"; 43:          "TRAK";SCL R0-2C
,.94(R5-R4)+R4;  DSP ;CMD "J?";20 .CFG 0;IF B>R1; ,R1,R18-(R17-R18
PLT R5F          +R8;-9E99+R17;9E GT0 +2F    )/10;R17F
10:            99+R18F          44:          61:
LTR -1.25C+R0,.0  26:          GT0 "LOOP" F    AXE R1-2C,R18,C;
6(R5-R4)+R4,211; CMD "U?>","A1" F 45:          (R17-R18)/10F
PLT "FMIN"  F    27:          RET F          62:
11:            "LOOP";CMD "U?=" 46:          DSP "CHANGE PEN?
LTR -2C+R0,.03(R , "E0","U?<";FMT "AUTO F";CMD "U?.";STP F
5-R4)+R4;PLT R4F FXD *.0;WRT 13;1 *","I2E9:8I1"; 63:
12:            00*BF          DSP ;CMD "J?";13 LTR R1-1.5C,.7(R
LTR .45(R1-R0)+R 28:          +R12F    17-R18)+R18,324;
0,R4-X,321;PLT "  CMD "U?0";FMT 47:          PLT "TRACKING ER
VOLTS" F    FXD 12.2;WRT 13;  CMD "U?=","E0"," ROR " F
13:            BF          U?<";FMT FXD *.0 64:
LTR .95(R1-R0)+R 29:          ;WRT 13,100*R0F  PLT "(%) " F
0,-.3X+R4,211;  CMD "U?*","J1"," 48:          65:
PLT "VMAX"  F    J?35";FMT *;RED "LOP2";CMD "U?>" LTR R1-1.9C,.97(
14:            13,R6F    , "A1";DSP F    R17-R18)+R18,211
FXD 2;LTR .95(R1 30:          49:          ;PLT R17F
-R0)+R0,-.6X+R4; CMD "U?>","A2" F  CMD "U?*","J1"," 66:
PLT R1F        31:          J?5";FMT *;RED 1 LTR R1-1.9C,.03(
15:            IF B≠R0;PLT R11,  F    3,R R12;R12+1+R12 R17-R18)+R18,211
LTR .015(R1-R0)+ R9F          F    ;PLT R18F
R0,-.3X+R4,211;  32:          50:          67:
PLT "VMIN " F    PLT B,R6;PEN F  CMD "U?>","A2";  R0+B;20+R8F
16:            33:          DSP F          68:
LTR .015(R1-R0)+  CMD "U?*","J1"," 51:          "LOP3";PLT B,RR8
R0,-.6X+R4;PLT R J?25";FMT *;RED  CMD "U?*","J1","  F
0F            13,R7F    J?5";FMT *;RED 1 69:
17:            34:          3,RR12F    B+A+B;R8+1+R8;
LTR 9.65C+R0,-.3  CMD "U?>","A1" F 52:          IF B>R1;GT0 +2F
X+R4;PLT 10C+R0F 35:          IF R12>14;GT0 +3 70:
18:            IF B≠R0;PLT R11,  F    GT0 "LOP3" F
LTR .35(R1-R0)+R R10F          53:          71:
0,R5-.3X,421;    36:          CMD "U?<";FMT  RET F
PLT "DUAL VCO" F  PLT B,R7;PEN F  FXD *.0;WRT 13;1 72:
19:            37:          00*R1F    END F
LTR .35(R1-R0)+R (R6-R7)*100/R6+R 54:          R174
0,-.7X+R5,211;  R8F          R12+1+R12;GT0 "L
PLT "VOLTS VS FR 38:          OP2" F
EQUENCY" F    IF RR8>R17;RR8+R 55:
20:            17F    IF R13<R14;R13+R
GSB "MEAS"  F    39:          4F
21:            IF RR8<R18;RR8+R 56:
ENT "TRACKING? 1 18F    IF R13>R14;R14+R
OR 0";ZF      40:          4F
22:            CMD "U?1";FMT 57:
IF Z;GSB "TRAK" F FLT *.5;WRT 13;R IF R15>R16;R15+R
23:            R8;R8+1+R8F    5F

```