



# Oscilloscope probing for high-speed signals

Application Note 1607

## Introduction

If you want to make accurate oscilloscope measurements on high-speed signals, it is critical that you select your probes with care and use them properly. The probe is the dominant factor in determining the noise floor and response of your measurement system. Probe loading effects on the circuit under test are also a critical consideration.

This application note discusses active probes with bandwidths greater than 1 GHz.

When you choose a probe, you need to evaluate four aspects:

- Response,  $V_{out}/V_{in}$
- Target loading at low and high frequencies
- Noise
- Adaptability and ease of use for probing various targets



Agilent Technologies

## InfiniiMax probe architecture

The InfiniiMax probe architecture pioneered by Agilent Technologies optimizes all of these aspects. The key to the InfiniiMax architecture is separating the probe head from the probe amplifier. This architecture enables small probe heads that can access restricted spaces while simultaneously optimizing response and loading.

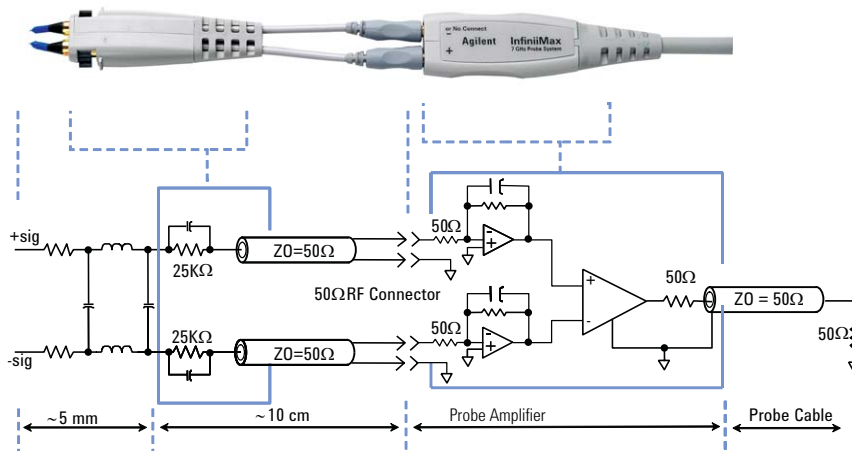

Figure 1. InfiniiMax architecture

Overall dimensions of this region are the most critical determinant of a probe's performance at high frequencies.

The response and loading of a probe are dominated by the dimensions of the connection to the circuit under test. The smaller these dimensions, the lower the capacitance and inductance in this part of the circuit. The InfiniiMax probe head design reduces these dimensions to the practical limit.

Once the signal leaves the probe head on its way to the probe amplifier, it is in a controlled 50-ohm environment. In a properly terminated 50-ohm system, cable length has minimal impact on response. If you need to separate the probe head further from the probe amplifier, you can even add extender cables between the probe head and the probe amplifier with minimal impact on performance. See Application Note 1601, "Extending the Range of Agilent InfiniiMax Probes," <http://cp.literature.agilent.com/litweb/pdf/5989-7587EN.pdf>.

The InfiniiMax architecture is inherently differential. Even if you're measuring a single-ended signal, a differential probe

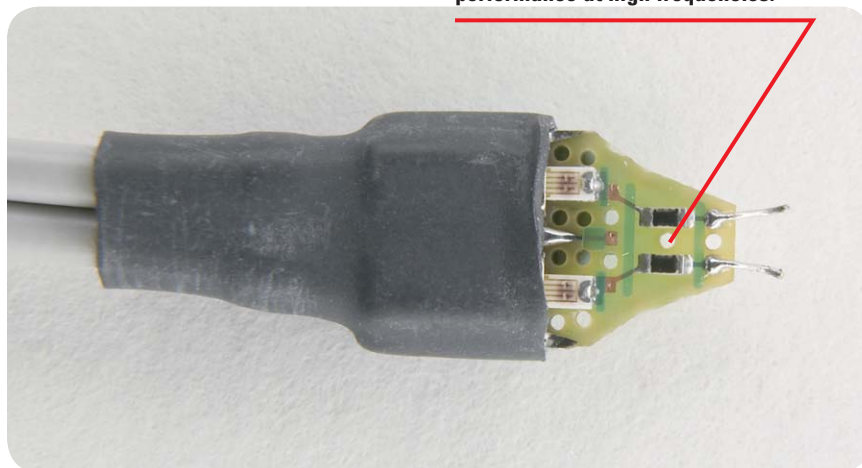

Figure 2. InfiniiMax solder-in probe head detail

always provides superior results, especially as the bandwidth of the signal increases. Remember, all signals are differential; "ground" is a convenient fantasy. A differential probe will have lower loading (higher impedance) for high-frequency signals in addition to higher common mode rejection ratio (CMRR). To learn more about the advantages of differential probes for measuring single-ended signals, refer to Application Note 1419-03, "Performance Comparison of Differential and Single-Ended Active Voltage Probes," <http://cp.literature.agilent.com/>

[litweb/pdf/5988-8006EN.pdf](http://cp.literature.agilent.com/litweb/pdf/5988-8006EN.pdf).

The additional offset range available in an active probe is a benefit of using probes that is often overlooked. This additional offset range makes it possible to measure small AC signals riding on a large DC offset with good resolution. To learn more about this, see Application Note 1451, "Understanding and Using Offset in InfiniiMax Active Probes," <http://cp.literature.agilent.com/litweb/pdf/5988-9264EN.pdf>

# Response

The most meaningful way to characterize the time domain and frequency domain response of a probe is to characterize the output of the probe as a function of the input at the probe tips. Defining the response this way allows you to evaluate the probe's accuracy in reproducing the actual signal present in your system with the probe attached. Some manufacturers define probe response as  $V_{out}/V_{source}$ , in other words, "what would be there if the probe were not present." Some manufacturers design their probes and DSP correction software to display what the waveform "would have been" in the absence of the probe

When you define response this way, you must make a number of assumptions about the nature of the system under test, and the response can only be defined for a specific test configuration. This can lead to erroneous assumptions about how the probe's response will affect your measurement on your system under test. Also, if the probe's loading causes your circuit to lose some timing or amplitude margin, you probably want to know that when you make a measurement.  $V_{out}/V_{source}$  compensation will hide these effects from you.

The responses of all combinations of probe head and probe amplifier are documented in the probe user's guides, which are available online. For example, consider the 1169A 12-GHz probe amplifier and the N5381A 12-GHz solder-in probe head. In the 1169A user's guide, <http://cp.literature.agilent.com/litweb/pdf/01169-97007.pdf>, the time domain step response is shown in Figure 2-18, page 2-24, and reproduced in Figure 3.

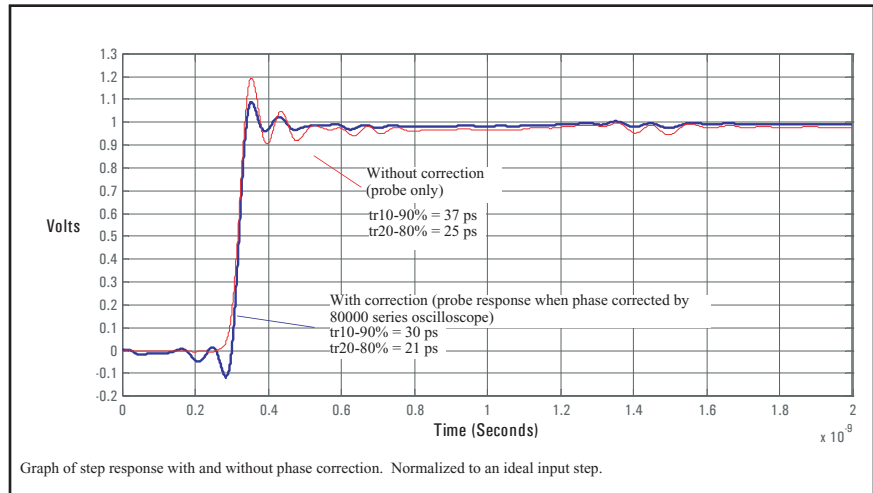

Figure 3. Time domain response of N5381A solder-in probe head and 1169A probe amplifier

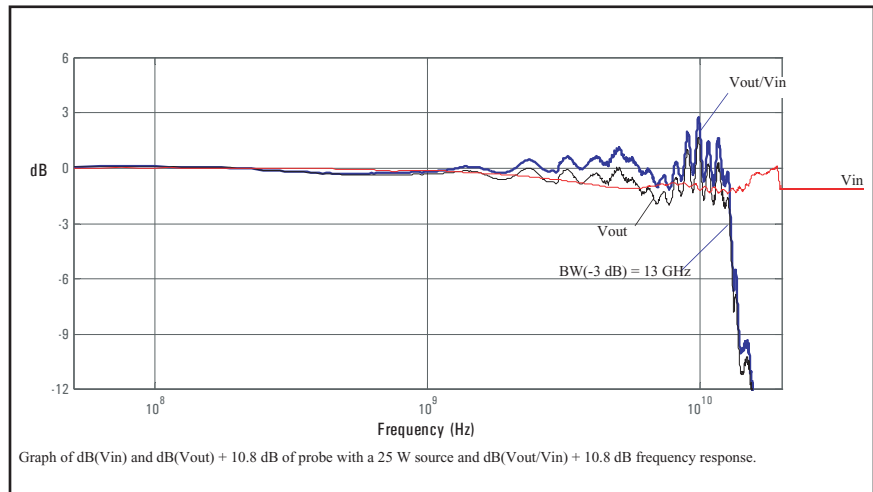

Figure 4. Frequency domain (magnitude) response of N5381A solder-in probe head and 1169A probe amplifier

Note that when the probe is used with the Agilent DSO/DSA80000 and DSO/DSA90000 Series scopes, DSP processing takes place in the scope to further correct the probe response in both magnitude and phase. The graph shows the response both with and without DSP correction.

## Target system loading

Target system loading is the second critical aspect of a probe system. Excessive loading at low and mid-band frequencies will reduce the amplitude of signals under test, thus reducing the margin for amplitude tests or in some cases causing a “good” system to actually fail. Some manufacturers probes have impedance on the order of 450 ohms at mid-band frequencies, which will result in a 5% reduction in signal amplitude when probing a 50-ohm transmission line. Excessive loading at high frequencies will increase the rise and fall times of signals in the system under test, as well as introducing delay and intersymbol interference (ISI).

Loading for all Agilent InfiniiMax probes is documented in the user’s guides. For example, consider the N5381A 12-GHz solder-in probe head. In the user’s guide, <http://cp.literature.agilent.com/litweb/pdf/01169-97007.pdf>, the time domain loading is shown in Figure 2-19 on page 2-24 and in Figure 5.

The blue trace is a step with 58-ps rise time on a 50-ohm transmission line without the probe attached. The red trace shows how the signal on the transmission line changes when the probe head is attached.

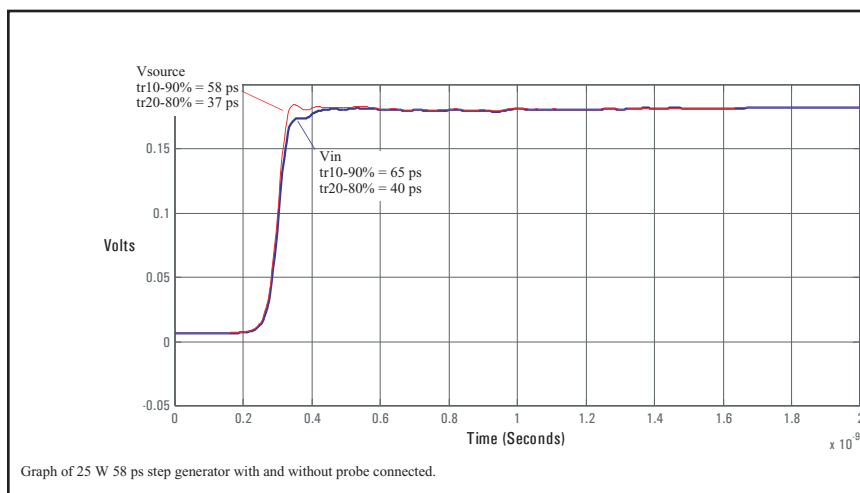

Figure 5. Time-domain loading for N5381A solder-in probe head

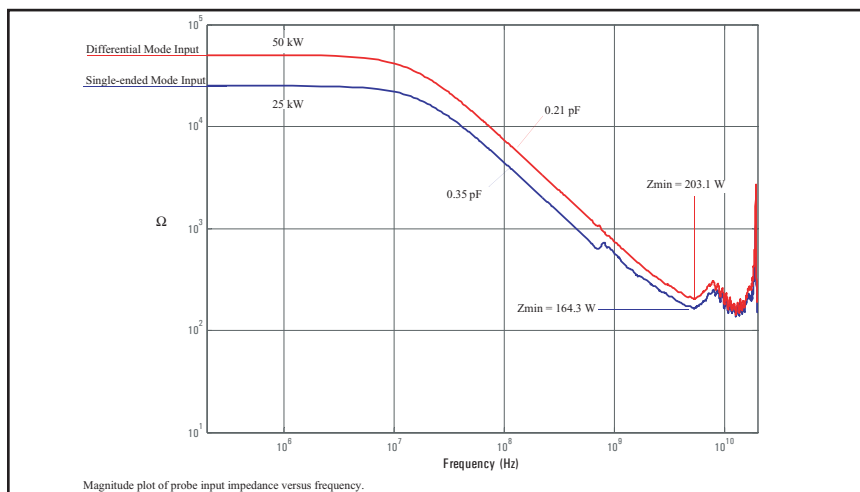

Figure 6. Frequency domain loading of the N5381A probe head

The frequency domain loading is shown in Figure 2-23 on page 2-26 of the user’s guide, and in Figure 6

In Figure 6 you can see how the differential mode input impedance is always higher than the single-ended mode input impedance.

Spice models are available for all high-impedance InfiniiMax probe heads. You can use these models to simulate how the probe’s loading will affect the operation of your circuit. The Spice models are provided in the user’s guides. In the 1169A User’s Guide, the Spice models begin on page 3-1.

## Noise

Probe noise is typically larger than the scope's noise floor, so choosing a probe with a low noise floor is critical to accurate measurements. Noise is translated into jitter by the slope of the signal, so noise also has an impact on jitter measurements. Noise becomes more pronounced the slower the slew rate of the signal. Agilent's 1168A and 1169A InfiniiMax probes have an exceptionally low noise floor of 2.6 mV rms referenced to the probe input.

## Adaptability

The InfiniiMax architecture gives you the flexibility to probe a wide variety of target system configurations. Probe heads available include:

- 7- and 12-GHz solder-in probe heads
- 12-GHz ZIF (zero insertion force) probe heads and tips
- 6- and 12-GHz differential handheld browser heads
- 5-GHz single-ended browser probe head
- 12-GHz socketed probe head
- 7- and 12-GHz dual-SMA probe heads

All probe heads are differential with the exception of the E2676A single-ended browser probe head.

## Wire length

The two points where you have to attach a probe may not always be conveniently located close together. The E2677A solder-in probe head, the N5451A long-wire ZIF tip, and the E2677A socketed probe head all provide facilities for attaching various wire lengths to accommodate different spacings.

You need to make tradeoffs with longer wire connections to the target. The longer the wires, the greater the loading, and the first resonant frequency will be lower in both the loading and the response. For each longer wire solution, optimized damping resistors are chosen to provide optimal damping of both loading and response. This results in lower bandwidth, but suppresses the resonances to flatten out both the response and the loading. The probe user's guide shows the response and the loading for

each solution. For example, in the 1169A User's Guide, starting on page 2-24, there is a discussion of the N5451A long-wire ZIF tips. The loading and response of any long-connection solution also depend on the angle of the wires, so for the long-wire ZIF tips, the manual shows the response and loading with zero degrees separation and with 60 degrees of separation of the resistor leads.

You should also bear in mind that signals that are widely separated in space are not truly "differential" because the fields are not coupled, therefore there is not a true "differential" mode, only two single-ended modes.

The response and loading data for the E2677A differential solder-in probe head with medium-bandwidth resistors can be found in the 1134A User's Guide <http://cp.literature.agilent.com/litweb/pdf/01134-97009.pdf> starting on page 1-34.

ZIF probe head N5425A attached to ZIF tip

**ZIF probe heads and tips**

The N5425A ZIF probe head and N5426A ZIF tips save money and are very convenient when you need to move probes around to many probe points in a target system. The cost of the ZIF tips is much less than the cost of a probe head. Each ZIF tip model number includes ten ZIF tips. Long-wire ZIF tips, model number N5451A, are available to accommodate wider-spaced probe points.

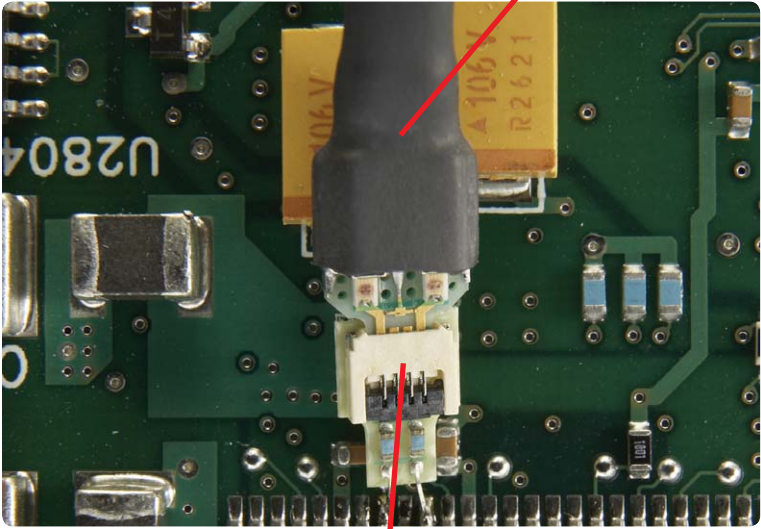

ZIF tip soldered to target

ZIF probe head N5425A

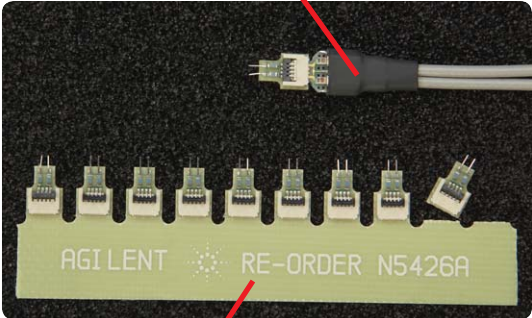

ZIF tip N5426A

**Figure 7. N5425A ZIF probe head and N5426A ZIF tips**

## Dual-SMA probe heads

Two dual-SMA probe heads are available, E2695A (7 GHz) and N5380A (12 GHz). If you have RF coaxial connectors for your signal under test, why would you use a differential SMA probe rather than simply connect the signals to two channels of the scope with coaxial cables and use a math function to subtract the two components of the differential signal?

There are multiple advantages of using a probe with a differential SMA probe head. If you use cables to connect differential signals to two channels of the scope, the results are critically dependent on properly adjusting the skew between the two signals. The common mode rejection ratio is dependent on any slight calibration differences between the two channels. When you use the differential probe, you don't need to worry about adjusting channel-to-channel skew or individual channel gain calibrations.

When you use coaxial cables to connect the two sides of the differential signal (or a single-ended signal) to the scope, the S-parameters of the coax cable affect the measurement accuracy. (It is of course possible to de-embed the cables if you have a good model for the cables). The probe, on the other hand, has compensation designed in for the cable connecting the probe

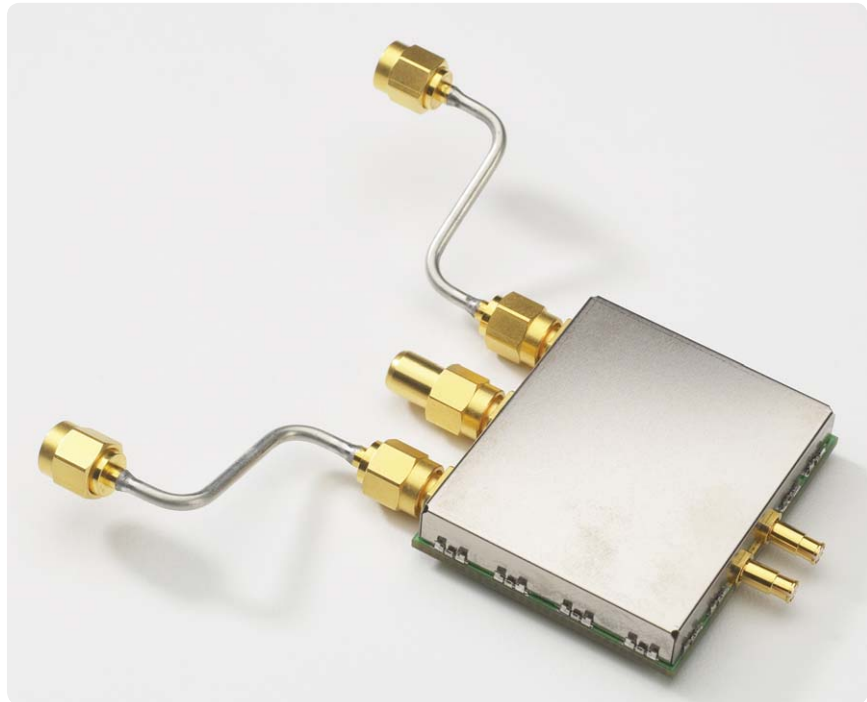

Figure 8. N5380A dual-SMA differential probe head

amplifier to the scope and for its internal circuits. When you use the 1168A or 1169A probe with a DSO/DSA80000B or DSO/DSA90000A Series scope, the scope automatically applies DSP filters to provide further response flattening.

If you use coaxial cables and math functions to measure differential signals, two scope channels are required for each differential signal, which limits you to two differential signals that can be acquired simultaneously. By using differential probes,

you can acquire four signals simultaneously. This allows you, for example, to view two lanes simultaneously, where each lane consists of one differential pair transmitting in each direction.

The principal disadvantage of using a probe instead of direct coaxial cables is that the probe contributes noise.

## Probe head extension

You may need to monitor a system in a temperature chamber with an oscilloscope probe to characterize performance of your device or system over a wide range of operating temperatures, or to determine the cause of failures at high or low temperatures. Agilent InfiniiMax probe amplifiers have a specified operating temperature range from 5 degrees C to 40 degrees C. However, the probe heads can be operated over a much wider range. You can use the Agilent N5450A extension cable set (Figure 9) to physically separate the probe heads from the probe amplifiers. This will allow you to operate the probe heads inside a temperature chamber with the probe amplifier located outside the temperature chamber. Refer to Application Note 1601, “Extending the Range of Agilent InfiniiMax Probes,” <http://cp.literature.agilent.com/litweb/pdf/5989-7587EN.pdf> for more details.



Figure 9. InfiniiMax probe head and N5450A extension cables connected to probe amplifier

## Extending the dynamic range of probes

The dynamic range of the 1130 series is 5 V p-p; the dynamic range of the 1160 series is 3.3 V p-p. If you need to measure larger signals, the architecture of the InfiniiMax probes allows you to add coaxial RF attenuators between the probe head and the probe amplifier to increase the dynamic range. Attenuators also allow you to increase the offset range of the probe. For details refer to “Extending the Range of Agilent InfiniiMax Probes,” as cited above.



## Notes on fully characterizing differential signals

To completely characterize differential signals you need to measure:

- The differential mode component of the differential signal ( $V_p - V_m$ )
- The common mode component of the differential signal ( $V_{cmsig}$ )

To make these measurements with single-ended probes, you would connect one single-ended probe between  $V_p$  and  $V_{gd}$  (refer to figure 10) and to one channel of a scope, and another single-ended probe between  $V_m$  and  $V_{gd}$  and to a second channel of the scope. You would then use math functions in the scope to derive the common mode and differential signals. The common mode signal  $V_{cmsig}$  is equal to  $(V_p + V_m)/2$ .

Due to ground connection inductance, single ended probes typically don't reject the  $V_{cmdut}$  component very well, especially at higher frequencies. This will corrupt the measurement of  $V_{cmsig}$  since it should not include the  $V_{cmdut}$  component.

The ground connection inductance also allows spurious signals to be launched onto the coax shield of the probe. The routing and position of the probe coax will determine how this signal will be reflected back to the probe tip ground. This reflected signal affects the measured signal and causes repeatability problems if the probe cable is moved.

All signals can be derived by using two differential probes and math functions in the scope. Connect one differential probe between  $V_p$  and  $V_{gd}$  (refer to figure 10) and to one channel of a scope, and another differential probe between  $V_m$  and  $V_{gd}$  and to a second channel of the scope. The differential and common mode signals can be derived by using math functions in the scope. Alternatively, you can use one differential probe to measure  $V_p - V_m$  directly. The advantage of using two probes connected to  $V_p$  and  $V_m$  is that both differential and common mode signals can be measured with one connection and only two probes. The individual signals  $V_p$  and  $V_m$  can also be observed. This may be valuable for troubleshooting, for example, if only one side is exhibiting overshoot or crosstalk.

A differential probe with good common mode rejection will greatly attenuate the  $V_{cmdut}$  component when measuring  $V_p - V_{gd}$  and  $V_m - V_{gd}$ .

The common mode rejection will also significantly attenuate any signal that is launched onto the probe coaxes and reflected back to the probe tip ground.

A differential probe can directly measure  $V_p - V_m$ . This allows the user to verify that the indirect measurement (i.e. the difference of the two signals) agrees with the direct measurement and thus ensure that the two probes are properly de-skewed.

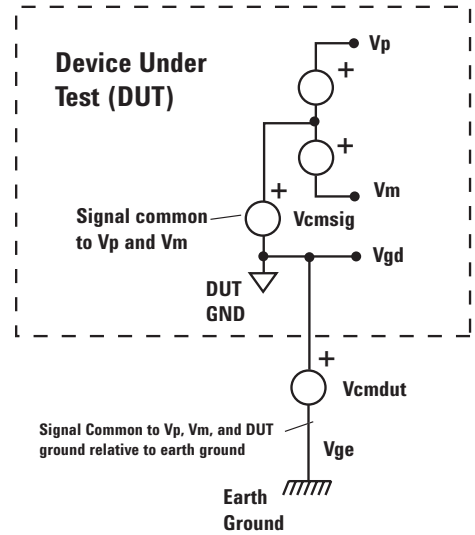

Figure 10 A differential signaling system to be measured

## Summary

The Agilent InfiniiMax probing system offers an optimized combination of response fidelity, loading, low noise, and accessibility for a wide variety of probing challenges. Understanding the tradeoffs of the available probe amplifiers, probe heads, and accessories will help you make the best measurements on your system under test.

## References

1134A 7-GHz InfiniiMax Differential and Single-Ended Probes User's Guide, <http://cp.literature.agilent.com/litweb/pdf/01134-97009.pdf>

1168A and 1169A InfiniiMax Differential and Single-Ended Probes User's Guide, <http://cp.literature.agilent.com/litweb/pdf/01169-97007.pdf>

Performance Comparison of Differential and Single-Ended Active Voltage Probes, Application Note 1419-03, Agilent publication number 5988-8006EN, <http://cp.literature.agilent.com/litweb/pdf/5988-8006EN.pdf>

Video "Probe Loading,"

[http://www.home.agilent.com/agilent/redirector.jsp?action=ref&cname=AGILENT\\_EDITORIAL&ckey=773058&lc=eng&cc=US&nfr=-536902755.0.00](http://www.home.agilent.com/agilent/redirector.jsp?action=ref&cname=AGILENT_EDITORIAL&ckey=773058&lc=eng&cc=US&nfr=-536902755.0.00)

Improving Usability and Performance in High-Bandwidth Active Oscilloscope Probes, Application Note 1419-02, Agilent publication number 5988-8005, <http://cp.literature.agilent.com/litweb/pdf/5988-8005EN.pdf>

Understanding and Using Offset in InfiniiMax Active Probes, Application Note 1451, Agilent publication number 5988-9264EN, <http://cp.literature.agilent.com/litweb/pdf/5988-9264EN.pdf>

Video "Flexibility of Agilent's InfiniiMax Probe System,"

[http://www.home.agilent.com/agilent/redirector.jsp?action=ref&cname=AGILENT\\_EDITORIAL&ckey=558421&lc=eng&cc=US&nfr=-536902770.0.00](http://www.home.agilent.com/agilent/redirector.jsp?action=ref&cname=AGILENT_EDITORIAL&ckey=558421&lc=eng&cc=US&nfr=-536902770.0.00)

## Related Agilent Literature

Publication	Description	Publication Number
<i>Performance Comparison of Differential and Single-Ended Active Voltage Probes</i>	Application note	5988-8006EN
<i>Understanding and Using Offset in InfiniiMax Active Probes</i>	Application note	5988-9264EN
<i>Extending the Range of Agilent InfiniiMax Probes</i>	Application note	5989-7587EN



## Agilent Technologies Oscilloscopes

Multiple form factors from 20 MHz to >90 GHz | Industry leading specs | Powerful applications



### Agilent Email Updates

[www.agilent.com/find/emailupdates](http://www.agilent.com/find/emailupdates)

Get the latest information on the products and applications you select.



### Agilent Direct

[www.agilent.com/find/agilentdirect](http://www.agilent.com/find/agilentdirect)

Quickly choose and use your test equipment solutions with confidence.



[www.agilent.com/find/open](http://www.agilent.com/find/open)

Agilent Open simplifies the process of connecting and programming test systems to help engineers design, validate and manufacture electronic products. Agilent offers open connectivity for a broad range of system-ready instruments, open industry software, PC-standard I/O and global support, which are combined to more easily integrate test system development.



[www.lxistandard.org](http://www.lxistandard.org)

LXI is the LAN-based successor to GPIB, providing faster, more efficient connectivity. Agilent is a founding member of the LXI consortium.

Windows® is a U.S. registered trademark of Microsoft Corporation.

## Remove all doubt

Our repair and calibration services will get your equipment back to you, performing like new, when promised. You will get full value out of your Agilent equipment throughout its lifetime. Your equipment will be serviced by Agilent-trained technicians using the latest factory calibration procedures, automated repair diagnostics and genuine parts. You will always have the utmost confidence in your measurements.

Agilent offers a wide range of additional expert test and measurement services for your equipment, including initial start-up assistance onsite education and training, as well as design, system integration, and project management.

For more information on repair and calibration services, go to

[www.agilent.com/find/removealldoubt](http://www.agilent.com/find/removealldoubt)

## www.agilent.com

For more information on Agilent Technologies' products, applications or services, please contact your local Agilent office. The complete list is available at:

[www.agilent.com/find/contactus](http://www.agilent.com/find/contactus)

### Phone

#### Americas

Canada	(877) 894-4414
Latin America	305 269 7500
United States	(800) 829-4444

#### Asia Pacific

Australia	1 800 629 485
China	800 810 0189
Hong Kong	800 938 693
India	1 800 112 929
Japan	81 426 56 7832
Korea	080 769 0800
Malaysia	1 800 888 848
Singapore	1 800 375 8100
Taiwan	0800 047 866
Thailand	1 800 226 008

#### Europe

Austria	0820 87 44 11
Belgium	32 (0) 2 404 93 40
Denmark	45 70 13 15 15
Finland	358 (0) 10 855 2100
France	0825 010 700
Germany	01805 24 6333* *0.14€/minute
Ireland	1890 924 204
Italy	39 02 92 60 8484
Netherlands	31 (0) 20 547 2111
Spain	34 (91) 631 3300
Sweden	0200-88 22 55
Switzerland	(French) 44 (21) 8113811 (Opt 2)
Switzerland	(German) 0800 80 53 53 (Opt 1)
United Kingdom	44 (0) 7004 666666

Other European countries:  
[www.agilent.com/find/contactus](http://www.agilent.com/find/contactus)

Revised: March 23, 2007

Product specifications and descriptions in this document subject to change without notice.

© Agilent Technologies, Inc. 2001, 2008  
Printed in USA, September 3, 2008  
5989-9177EN



Agilent Technologies