

Debugging CAN-Based Designs More Efficiently with an Agilent 54600 Series Mixed-Signal Oscilloscope and a N2758A CAN Trigger Module

Application Note 1492

4 Applications

1 Isolating Bad Data

2 Unexpected CAN Bus Error

3 Latency Trigger/Characterization

4 LIN Bus Triggering

Introduction

Today, CAN (controller area network) buses are becoming commonplace in industrial machinery and factory automation applications. Today's cars use a CAN bus as the backbone for connecting controllers with sensors and actuators throughout the vehicle. However, CAN and other networks are a challenge to implement in an automobile. Many CAN-based designs have transitioned from pure analog or electro-mechanical to mixed analog and digital designs. These mixed-signal designs incorporate a wide variety of sensors and gages that convert physical

measurements to electrical signals, but they also contain digital components that implement increasingly complex controls and algorithms. In these mixed-signal designs, the real-world signals interacting with the CAN nodes are relatively slow compared to the fast digital control signals. In the past, you could use a 2- or 4-channel digital scope to get a quick understanding of your pure analog or electro-mechanical signal behaviors. However, a 2- or 4-channel digital scope is not sufficient for analyzing today's ever-more-complex mixed-signal designs, including CAN serial buses.



Introduction

Agilent's 54600 Series mixed-signal oscilloscopes (MSOs) seamlessly combine 16 digital timing channels and a 2-channel digital storage oscilloscope (DSO) into a unique and easy-to-use oscilloscope for these types of designs.

With the profusion of microcontrollers, many of the peripheral devices in your designs are likely to use serial interfaces. Agilent 54600 Series MSOs provide serial bus triggering that includes I²C, SPI, USB, CAN and LIN. Because serial interfaces are relatively slow, you need to capture longer time periods in order to see the details in your signal streams. The MSO's MegaZoom deep memory allows you to capture the big picture and the details of the serial control signals at the same time.

The CAN trigger feature (included standard with 54600 Series oscilloscopes) uses a start-of-frame (SOF) trigger that simply synchronizes to any CAN message, regardless of the message content. When you use the Agilent N2758A CAN trigger module with the 54600 Series mixed-signal oscilloscope, you have the ability to trigger on specific CAN message content and more. The CAN trigger module utilizes eight digital channels on the MSO.

In this application note, we will look into some real applications and discuss the benefits that Agilent 54600 Series MSOs and the N2758A trigger module provide to help you more quickly understand CAN-based design behaviors and thus get your products to market faster.

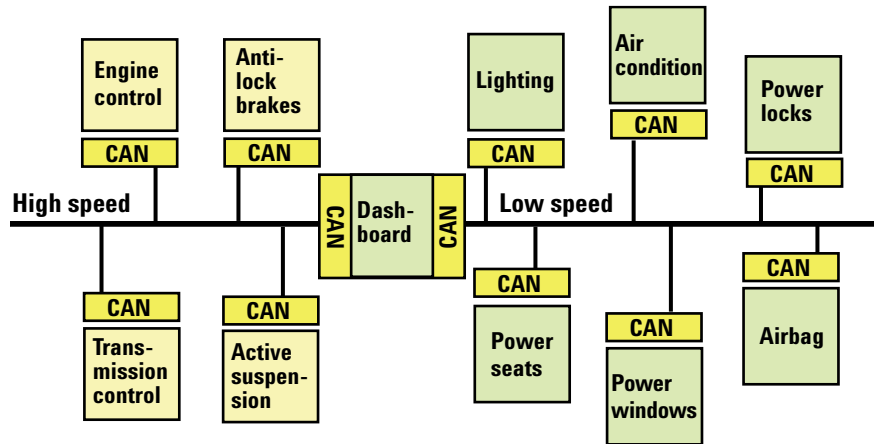

Figure 1. In automotive electronics, the use of CAN buses is commonplace.

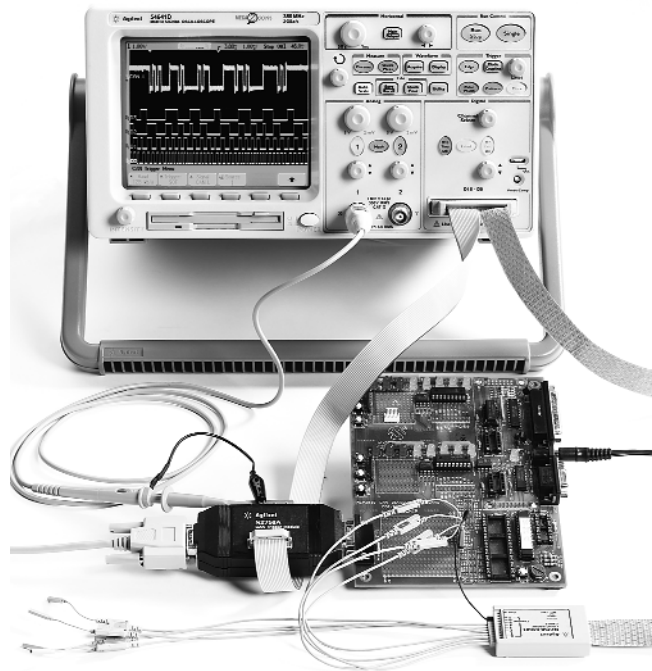

Figure 2. Agilent 54600 Series mixed-signal oscilloscope and N2758A CAN trigger module.

1 Application

Isolating Bad Data

Assume that a node is sending a message with unexpected data in it, and you monitor it in the master controller (or another node) and find it. You can use the N2758A to track down the source of the bad data and figure out how it was generated. You can set up the trigger spec to trigger only when a CAN message with the bad message ID or data occurs and trigger the scope for that bad message. Then you can use the two analog and eight remaining digital channels to investigate how the bad data is being generated by the node. The N2758A CAN trigger module allows the scope to trigger on standard IDs (11 bit), extended IDs (29 bit) or even a mixture of standard and extended IDs.

For example, if you have an A/D sensor that occasionally is clipped when you know it shouldn't be, you can easily set up a trigger that triggers on the sensor's message and the clipped data value. The scope triggers on the bad reading, and you can examine the A/D conversion to see why it was clipped, perhaps due to a setup-and-hold-time violation when the data is latched, or a power supply dropout during the conversion. Typical sensor found in automobiles include temperature sensors, speed rotation sensors and pressure (ABS) sensors.

These sensors should never produce negative readings, so if you observe a negative temperature, speed or brake pressure reading, or one that is outside the normal operating range, you can use the CAN trigger module to capture the bad data and investigate its cause.

In Figure 3, the scope triggered on the broadcast of the result of a sensor reading. The MSO triggers on the specific CAN message ID and data length, while also monitoring the SPI bus signal interactions to the sensor and the analog sensor input. The

top signal is the CAN Rx signal triggered on the bad CAN message. The second signal is the trigger pulse from the CAN module. The next three lines are digital channels showing SPI interface output to the sensor circuit, and the bottom signal is analog sensor input. There could be other analog or digital signals involved. Fortunately, the MSO with the N2758A has one more analog channel and several more digital channels to show you the full circuit activities. Using these tools, you can see the interactions between the CAN signals and other digital and analog signals.

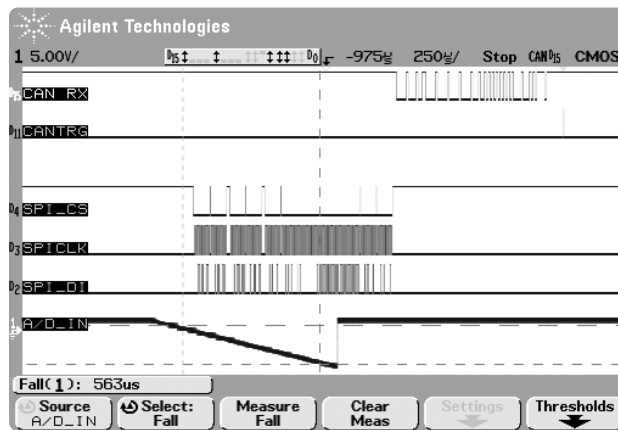

Figure 3. Here the scope triggers on the specific CAN message ID and data length, while also monitoring the SPI bus signals to the sensor with digital channels and analog sensor input with an analog channel.

Application

Unexpected CAN Bus Error

Suppose a node is causing intermittent errors on the bus, and therefore it is invalidating some of the messages by causing a CAN bus error frame. This error frame will cause the transmitter to retransmit, which will change the timing of the overall system running on the CAN network, perhaps disrupting some time-critical piece of information. Using the N2758A set to Error Trigger, the scope can trigger when error frames occur, and you can then use the other channels to understand why the node is causing the CAN error frame. You may discover logical domain issues like setup-and-hold time problems, or you may find the system in an incorrect or unexpected state. If you encounter parametric issues on the CAN bus differential signals, you could use the analog channels to look at the CAN_L or CAN_H probe lugs. Agilent also provides affordable differential probes such as the N2772A for acquiring the true differential CAN signals (CAN_H and CAN_L) without common mode deviations.

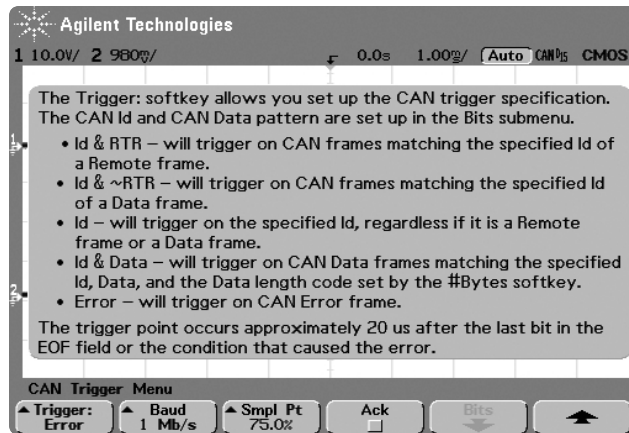

Figure 4. Using the N2758A set to “Error Trigger,” the scope can trigger when error frames occur.

Application

Latency Trigger/Characterization

Sometimes when a CAN-based system is not behaving as you expect it to, one of the symptoms is a change in time interval between messages. The time between two events is called latency. Latency measurement is very important in CAN-based design. The N2758A architecture is very powerful and unique in that it can measure and trigger on the time between messages that meet your CAN trigger specification. The N2758A allows you to trigger the CAN bus when a message is occurring within a specified time range (or before or after the specified time). This time range could indicate an error condition or it could be a system response specification and you could trigger on the system being out of spec. The CAN trigger module generates a trigger pulse for every frame matching your specification, which you can use as a trigger input for your MSO.

First, set up the N2758A to trigger on the message of interest in the CAN menu. This will generate a pulse on the CANTRG line back into the MSO for every message in the system that meets this spec. Then, using the scope's pulse width trigger with CANTRG as the source, you can selectively

trigger the scope for particular timing of the CAN message, thus isolating the behavior of interest. Then you can use the two analog and eight digital channels available to track down why the timing is not behaving as you expected.

In Figure 5, the scope is set to trigger only when the rebroadcast of a particular frame occurs between 45 msec and 75 msec. The top signal is the CAN Rx from the CAN trigger pod, and the bottom signal is the trigger pulse. The scope is set to trigger only if this broadcast is outside the expected cycle of 40 msec. If the node is operating out of spec, the MSO can trigger on the unexpected operation to help you understand what caused it.

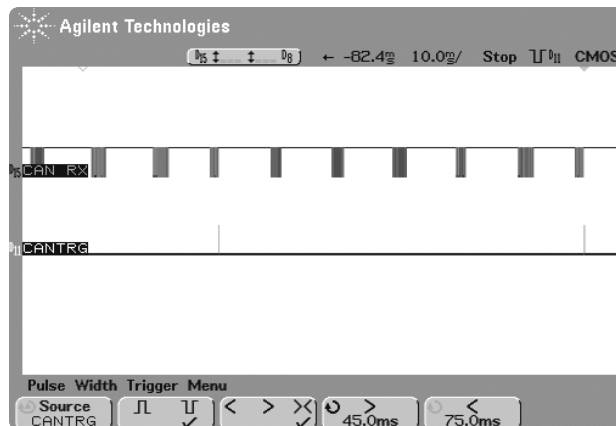

Figure 5. Here the scope is set to trigger only when the rebroadcast of a particular frame occurs between 45 ms and 75 ms.

Application

LIN Bus Triggering

The CAN backbone is not always the best choice for connecting all car functions. For example, you do not need the performance of a 32-bit microcontroller or the speed of a CAN bus (typically 200 kb/sec to 1 Mb/sec) for implementing functions such as operating power windows, locking doors and controlling seats. When you need a lower-speed/lower-cost connection, you can use a LIN (local interconnect network) bus that has a single-master/multiple-slave structure with data rates about 20 kb/sec. A LIN triggering feature is standard on all 54600 Series oscilloscopes, and it triggers on the rising edge at the sync break exit of the LIN single-wire bus signal that marks the beginning of the message frame. It allows you to trigger the scope whenever a LIN message transmission is started and avoid triggering the scope in the middle of a LIN message transmission.

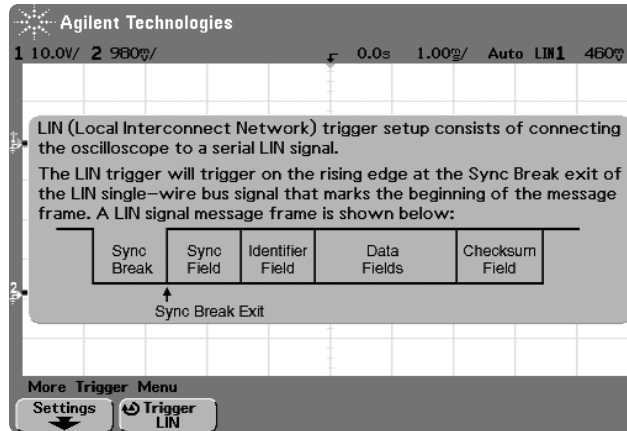

Figure 6. With LIN triggering, you trigger on the beginning of the LIN message frame.

Applications

Conclusion

The Agilent mixed-signal oscilloscope, used in conjunction with the N2758A CAN trigger module, is a powerful CAN design tool that lets you view time-correlated CAN messages and other analog and digital signals. The CAN trigger module

allows a higher level of triggering directly on serial message content and measuring latency between occurrences of user-defined CAN frames. These capabilities should help you quickly turn on and verify CAN-based mixed analog and digital designs.

Glossary

CAN (controller area network) bus A simple, two-wire differential serial bus. CAN buses operate in noisy environments with a high level of data integrity.

LIN (local interconnect network) bus A low-cost, single-wire bus for automotive and industrial applications.

Related Literature

Publication Title	Publication Type	Publication Number
<i>Agilent Technologies 54600 Series Oscilloscopes</i>	Data Sheet	5968-8152EN
<i>Agilent Technologies 54600 Series Oscilloscope Probes and Accessories</i>	Selection Guide Data Sheet	5968-8153EN
<i>Debugging Serial Bus Systems with a Mixed-Signal Oscilloscope</i>	Application Note 1395	5988-5997EN

For copies of this literature, contact your Agilent representative or visit www.agilent.com/find/scopes

Agilent Technologies' Test and Measurement Support, Services, and Assistance

Agilent Technologies aims to maximize the value you receive, while minimizing your risk and problems. We strive to ensure that you get the test and measurement capabilities you paid for and obtain the support you need. Our extensive support resources and services can help you choose the right Agilent products for your applications and apply them successfully. Every instrument and system we sell has a global warranty. Support is available for at least five years beyond the production life of the product. Two concepts underlie Agilent's overall support policy: "Our Promise" and "Your Advantage."

Our Promise

Our Promise means your Agilent test and measurement equipment will meet its advertised performance and functionality. When you are choosing new equipment, we will help you with product information, including realistic performance specifications and practical recommendations from experienced test engineers. When you use Agilent equipment, we can verify that it works properly, help with product operation, and provide basic measurement assistance for the use of specified capabilities, at no extra cost upon request. Many self-help tools are available.

Your Advantage

Your Advantage means that Agilent offers a wide range of additional expert test and measurement services, which you can purchase according to your unique technical and business needs. Solve problems efficiently and gain a competitive edge by contracting with us for calibration, extra-cost upgrades, out-of-warranty repairs, and on-site education and training, as well as design, system integration, project management, and other professional engineering services. Experienced Agilent engineers and technicians worldwide can help you maximize your productivity, optimize the return on investment of your Agilent instruments and systems, and obtain dependable measurement accuracy for the life of those products.



Agilent Email Updates

www.agilent.com/find/emailupdates

Get the latest information on the products and applications you select.



Agilent Direct

www.agilent.com/find/agilentdirect

Quickly choose and use your test equipment solutions with confidence.

Agilent T&M Software and Connectivity

Agilent's Test and Measurement software and connectivity products, solutions and developer network allows you to take time out of connecting your instruments to your computer with tools based on PC standards, so you can focus on your tasks, not on your connections. Visit www.agilent.com/find/connectivity for more information.

By internet, phone, or fax, get assistance with all your test & measurement needs

Online assistance:

www.agilent.com/find/assist

Phone or Fax

United States:

(tel) 800 829 4444

Canada:

(tel) 877 894 4414

(fax) 905 282 6495

China:

(tel) 800 810 0189

(fax) 800 820 2816

Europe:

(tel) (31 20) 547 2323

(fax) (31 20) 547 2390

Japan:

(tel) (81) 426 56 7832

(fax) (81) 426 56 7840

Korea:

(tel) (82 2) 2004 5004

(fax) (82 2) 2004 5115

Latin America:

(tel) (305) 269 7500

(fax) (305) 269 7599

Taiwan:

(tel) 0800 047 866

(fax) 0800 286 331

Other Asia Pacific Countries:

(tel) (65) 6375 8100

(fax) (65) 6836 0252

Email: tm_asia@agilent.com

Product specifications and descriptions in this document subject to change without notice.

© Agilent Technologies, Inc. 2004

Printed in USA February 11, 2004

5989-0726EN

