

Agilent Noise Figure Measurements of Frequency Converting Devices

Using the Agilent NFA Series Noise Figure Analyzer

Application Note 1487



Agilent Technologies

Introduction

If you design or manufacture subsystems or components for today's complex RF systems you are likely to have a growing need to specify your product's noise figure. In a competitive market, that noise figure specification can be an essential means of differentiating your product. But measurement requirements are changing. Noise figure specifications are becoming tighter, requiring ever-greater measurement accuracy. Frequencies are moving higher, particularly in the fast-growing RF and microwave communications market. Competition among manufacturers is fierce, calling for faster, more efficient instruments and processes in design and production test.

The Agilent NFA Series noise figure analyzer (NFA) offers a number of different measurement modes. This application note provides details and examples about how to perform measurements using the Agilent NFA amplifier measurement mode (when the measurement frequency is outside the operating range of the NFA), the downconverter measurement mode, and the upconverter measurement mode.

1.0 Introducing the NFA

The Agilent NFA Series noise figure analyzer (NFA) was introduced during 2000/2001 as a replacement for the 8970 noise figure meter and 8971 noise figure test set. The NFA Series provides a single-instrument solution that can provide device characterization up to 26.5 GHz.

The Agilent NFA Series family comprises the following models:

- N8972A (10 MHz to 1.5 GHz).
- N8973A (10 MHz to 3.0 GHz).
- N8974A (10 MHz to 6.7 GHz).
- N8975A (10 MHz to 26.5 GHz).

Detailed information on the NFA Series can be found at www.agilent.com/find/nf

1.1 What devices can be measured?

The NFA offers a number of different measurement modes, the most appropriate depending on the type of device being measured. The following measurement modes are available:

Amplifier: Employed when the device under test (DUT) performs no frequency conversion. Examples of devices measured with this mode include amplifiers, filters, and attenuators.

There are two options available with this measurement mode:

- The DUT measurement frequency is within the operating frequency range of the NFA. No external equipment is required to perform the measurement.
- The measurement frequency is outside the operating frequency range of the NFA. External equipment such as a mixer or local oscillator) is required in the measurement system to bring the measurement frequency within the range of the NFA.

Downconverter: Employed when the DUT performs frequency downconversion. Examples of devices measured with this mode include mixers and receivers.

Upconverter: Employed when the DUT (such as a transmitter) performs frequency upconversion. The DUT can be a single component or a complex circuit.

Note:

This is the basic operating mode for the NFA.

2.0 Before You Begin

There are a number of important facts to consider before configuring a measurement. First, the correct equipment is important to the success of the measurement. A noise source is required to provide stimulus for the device under test. Measuring a frequency-converting device or measurements outside the frequency range of the NFA require a local oscillator. Filtering may be required and in some situations a preamplifier may be needed. A number of important criteria relating to the choice of equipment must be taken into account.

2.1 Choosing the correct noise source

When choosing a noise source make sure it covers the frequency range of the measurement and that its ENR (excess noise ratio) range is appropriate for the noise figure being measured. Agilent provides noise sources that cover frequencies from 10 MHz to 50 GHz with coaxial or waveguide connectors. The current range of Agilent noise sources is shown in Table 1:

Table 1. Agilent noise sources

Model number	Connector type	Frequency range	ENR range (dB)
346A	Coaxial	10 MHz – 18 GHz	4.5 – 6.5
346B	Coaxial	10 MHz – 18 GHz	14 – 16
346C	Coaxial	10 MHz – 26.5 GHz	12 – 17
346C (K01)	Coaxial	1 GHz – 50 GHz	6 – 21
R347B	Waveguide	26.5 GHz – 40 GHz	10 – 13
Q347B	Waveguide	33 GHz – 50 GHz	6 – 13
N4000A	Coaxial	10 MHz – 18 GHz	4.5 – 6.5
N4001A	Coaxial	10 MHz – 18 GHz	14 – 16
N4002A	Coaxial	10 MHz – 26.5 GHz	12 – 17

A noise source with the correct connector for the DUT should always be used rather than using an adapter. If adapters are used, adapter losses must be taken into consideration and should be compensated for using the NFA loss compensation function.

The Agilent 346B, 346C, N4001A, and N4002A are for general-purpose applications and can be used for noise figure measurements up to 30 dB. Special options (Option H01) are available which take the 346B/C nominal ENR up to 21 dB, which allows noise figure measurements up to 35 dB.

The 346A and N4000A can be used for noise figure measurements up to 20 dB. The lower ENR range sources are recommended for measuring low-noise-figure devices, as any detector linearity errors will be kept to a minimum. The 346A and N4000A are also recommended for measuring devices that are sensitive to port match caused by the small impedance change when the noise source is switched.

2.2 Choosing a local oscillator (LO)

Measuring the performance of frequency-translating devices or making measurements outside the standard frequency range of the NFA requires an LO. There are several important criteria that should be considered when choosing an LO, including:

- A frequency range appropriate for the frequency range of the DUT, the IF range, and sideband chosen.
- Sufficient power to drive mixers (typically +7 dBm)
- Noise performance
- GPIB connectivity
- SCPI compliance (recommended)

In most cases any Agilent or competitor's high-performance signal generator or synthesizer can be used as an LO with the NFA.

2.2.1 LO noise performance

The performance of the LO is important because phase noise, spectral purity, and the noise floor of the signal generator/synthesizer can all affect noise figure measurement results. Filtering may be required when using some signal generators or synthesizers to enable accurate noise figure measurements to be made. The only way to ensure the suitability of a particular LO may be by trying it out.

2.2.2 LO GPIB control

The NFA can control the LO via a dedicated GPIB port on the rear panel. The NFA uses a number of SCPI commands to set LO parameters such as frequency and power level. The LO GPIB command list is located under 'System', 'External LO', then 'LO Commands'. The default command list is shown in Table 2:

Table 2. Default commands

Command	SCPI used
Power Prefix	POW
Power Suffix	DBM
Frequency Prefix	FREQ
Frequency Suffix	HZ
Auxiliary Command	OUTP:STAT:ON

For example, the NFA would send 'FREQ 10000000HZ' over GPIB to set the LO to 10 MHz, or 'POW 7DBM' to set the LO power level.

The auxiliary command can be used to set the LO to the correct condition for use by the NFA. The default command shown in the table above 'OUTP:STAT:ON' sets the LO RF output to 'ON'. The default condition for a large number of Agilent signal generators and synthesizers is with the RF output set to 'OFF'.

The default condition for the LO is important for correct operation with the NFA. That is, if the default condition for the LO is 'SWEEP', the auxiliary command must be configured with the correct LO command to set the LO to 'CW'. Similarly, if the default for the LO is modulation set to 'ON', the auxiliary command must be configured to set this to 'OFF'. Each command can be modified and can contain up to 255 characters. If any command is modified, the external LO command set must be changed from 'SCPI' to 'Custom'.

2.2.3 Configuring the LO capabilities

The NFA can control a number of different LO capabilities. For example, it can vary the LO settling time it uses when communicating with the LO. The NFA waits for the settling time after sending any remote command before continuing. The minimum and maximum frequencies represent the capabilities of the external LO. The NFA uses these values as limits on the frequency that it will send to the external LO.

For measurements that use an external LO, the NFA controls the LO over the LO GPIB. However, there are situations in which it is useful to disable external LO control, especially when a fixed external LO is used. This could be when the LO cannot be controlled over GPIB, or the LO is part of the DUT (receivers, for example). If the LO is not being controlled by the NFA it is still necessary to enter the LO frequency into the NFA so the correct ENR frequencies can be used.

2.2.4 LO Multiplier function

Many signal generators and synthesizers have a multiplier function that can be used to increase the output frequency. In addition, external devices are available which can be used to multiply the output from a signal generator or synthesizer. The NFA can be configured to operate with these devices (external or signal generator/synthesizer based). The LO multiplier function is located under 'System', then 'External LO'.

In the following example the LO frequency will be swept from 24 to 27 GHz and the LO has a maximum multiplier of 4x. The NFA will control the NFA over GPIB. The NFA should be configured to sweep the LO from 24 to 27 GHz and the LO multiplier set to 3x. The LO multiplier function should be manually set to 3x, the same value as the NFA multiplier. The NFA will take the multiplier into account and sweep the LO from 8 to 9 GHz.

When using the LO multiplier the minimum and maximum frequency capabilities of the LO ('System', then 'External LO') refer to the multiplied frequency input to the DUT. For example, with a multiplier of 4 and an external LO that can operate from 10 MHz to 20 GHz; the limits should be set to 40 MHz and 80 GHz.

2.2.5 LO feedthrough with frequency-converting DUT

The NFA user calibration does not include the LO when frequency-converting devices are being measured. The NFA input attenuators are set according to the power measured during user calibration. The LO power is normally greater than the largest input signal that the DUT is intended to operate with. The LO power leaking from the DUT output is at a high level compared to the signal levels involved during measurement. If the LO is within the measurement range of the NFA, LO leakage may force the input attenuators to change range, which will render the measurement results inaccurate. Filtering may be required on the input to the NFA to prevent LO feedthrough.

Note:

If possible, the LO frequency should be outside the operating frequency range of the NFA to minimize the effect of any LO power leaking from the DUT.

2.3 Filtering requirements

Filtering may be required when performing noise figure measurements. The actual filtering requirements depend on the type of measurement being performed and the performance of some of the external equipment being used. The illustration in Figure 1 provides an example:

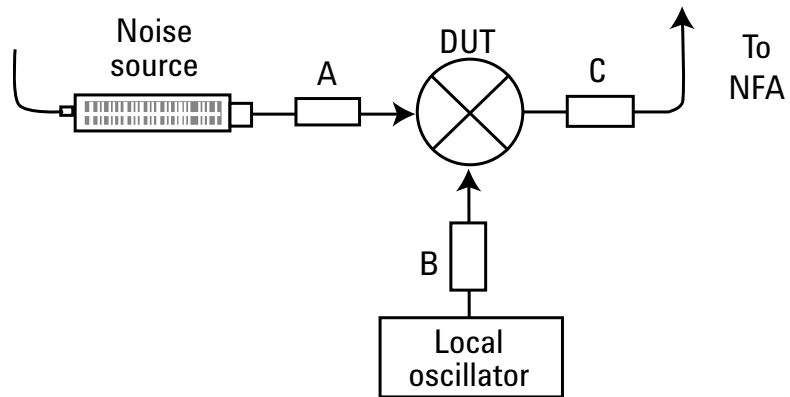

Figure 1. Where filtering is needed

Position A: Filtering is required here when a single-sideband measurement is being performed. This filter along with filtering built into the NFA will remove the unwanted sideband.

Position B: Filtering is required here if the noise performance of the LO is poor. This stops unwanted signals from the LO affecting the measurement results.

Position C: Filtering is required here to stop unwanted signals (either from the LO or the DUT input) that may leak from the DUT.

2.4 Preamplifier requirements

A low-noise preamplifier may be required to reduce measurement uncertainty if the DUT has little or no gain or the measurement system has high noise figure. The preamplifier should have enough gain to overcome the DUT's noise figure. The preamplifier gain should be limited because the preamplifier restricts the dynamic range of the NFA.

Choose a preamplifier with the correct connector for the noise source, and include the preamplifier as part of the calibration setup that measures the second-stage noise figure.

3.0 Measurement Frequency Planning

Noise figure and gain measurements are usually swept with respect to frequency. Measurements are defined in terms of RF (input to the DUT), IF (output from DUT), and LO.

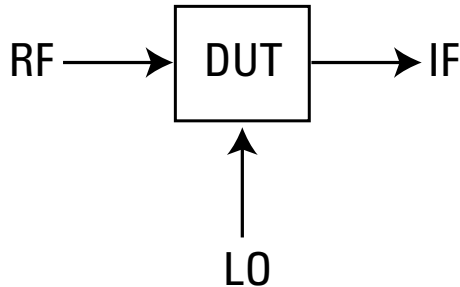

Figure 2. Terminology used at frequency ports

When the DUT performs frequency conversion or has a frequency of operation that is above that of the NFA, a downconverter is required to bring the frequency down to an IF that is within the range of the NFA. The frequency ranges involved in the measurement must be carefully planned.

3.1 Fixed LO versus fixed IF

The NFA provides the option of measuring with either the LO or the IF set to a fixed value.

3.1.1 Variable LO and fixed IF

Use a variable LO and fixed IF to explore the RF response of the DUT. The LO can be configured to sweep synchronously with the input frequency, and the NFA is set to a fixed IF frequency. After the IF frequency and range are set, the NFA calculates the frequencies for the LO sweep.

3.1.2 Variable IF and fixed LO

Use a variable IF and fixed LO to explore the IF response of the DUT. The LO can be a fixed value and the NFA input frequency can be set to sweep synchronously with the input frequency. Once the LO frequency and RF input frequency range are set, the NFA calculates the frequencies for the IF (instrument) sweep.

3.2 Sideband selection

The output from a simple mixer is both the sum and difference of the RF and LO frequencies. For any output frequency and LO frequency, there are two different input frequencies that are converted to the output frequency. The noise sources used in noise figure measurements are broadband, so noise will be presented to a simple mixer in both the upper and lower input frequency bands that are converted to the same IF output band to which the NFA is tuned.

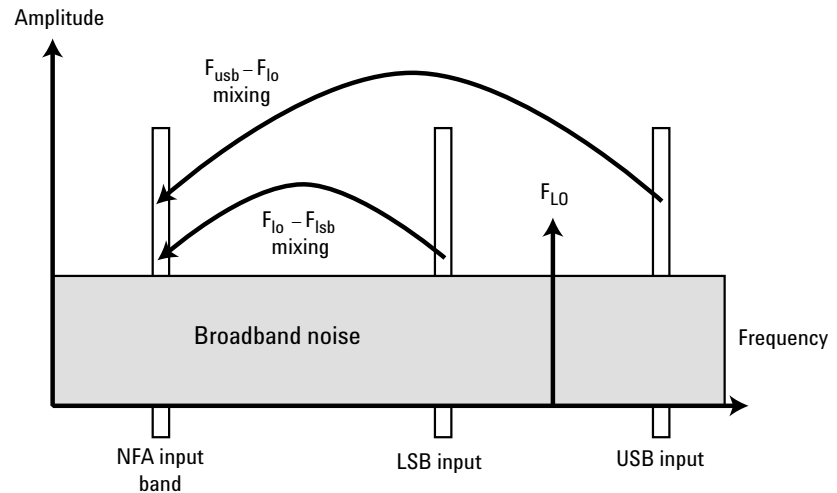

Figure 3. Sideband selection

The NFA receives noise (created by the noise source) from the two input frequency bands combined as added power. Any measurement in which two mixing products are combined like this is termed double sideband (DSB). Removing one of the input frequency bands results in a single-sideband (SSB) measurement. The NFA can perform both SSB and DSB measurements. However, care must be taken in selecting the type that is best suited to a specific measurement.

3.2.1 Double sideband (DSB) measurements

DSB measurements are often considered to be easier than single sideband (SSB) measurements because they avoid the added burden of image rejection filter design and characterization. The measured result for a DSB measurement is the average of the noise figure measured at LO+IF and LO-IF. If there are any differences in the noise power in the upper and lower sidebands, the DSB measurement will not be able to detect this and will cause an error. Choose the IF correctly for best results.

DSB is recommended when:

- The application is DSB
- The DUT is broadband
- The SSB system would be difficult or expensive to design
- No SSB filter is available

3.2.2 Single sideband (SSB) measurements

SSB measurements are considered to be more accurate than DSB measurements but are more difficult to set up. Filtering must be used to remove the unwanted sideband when performing a SSB measurement.

If a filter is used the losses attributed to it must be known and compensated for using the NFA loss compensation function.

SSB is recommended when:

- The application is SSB
- The DUT is narrowband
- A SSB filter is available

Care must be taken if SSB results are to be interpreted from DSB measurement figures. Under ideal conditions gain measurements will be 3 dB higher for DSB than with SSB, and noise figure will be 3 dB lower for DSB than with SSB.

4.0 Allowable Frequency Arrangements

The NFA has governing equations that control the frequency arrangements that are allowable for each measurement mode. This section details the arrangements of RF, IF, LO, sideband selections, and any restrictions that may exist for each mode.

The NFA relies on the user selecting the appropriate frequencies to suit the DUT, IF, and LO capabilities.

4.1 Amplifier mode

When the DUT has a frequency of operation outside the range of the NFA, frequency downconversion is required to bring the frequency down to a manageable IF. Frequency down conversion can be carried out using a stand-alone block down converter (e.g. Agilent N8975A option K40, or K50) or by using a mixer.

To measure devices with high gain an attenuator is required to protect the NFA input. Use the NFA loss compensation function to compensate for the loss

4.1.1 Variable frequency LO and fixed IF

The user specifies input frequencies to the NFA as RF (input to DUT) frequencies. The RF frequencies are also the ENR lookup frequencies. The LO must be connected to the LO GPIB port on the rear panel of the NFA. User calibration takes place at the RF frequencies and is performed with the noise source connected directly to the mixer RF input port. The DUT is then inserted as shown in Figure 4 and measurements are made. Additional filtering may be required for SSB measurements. This measurement is equivalent to 8970B mode 1.1.

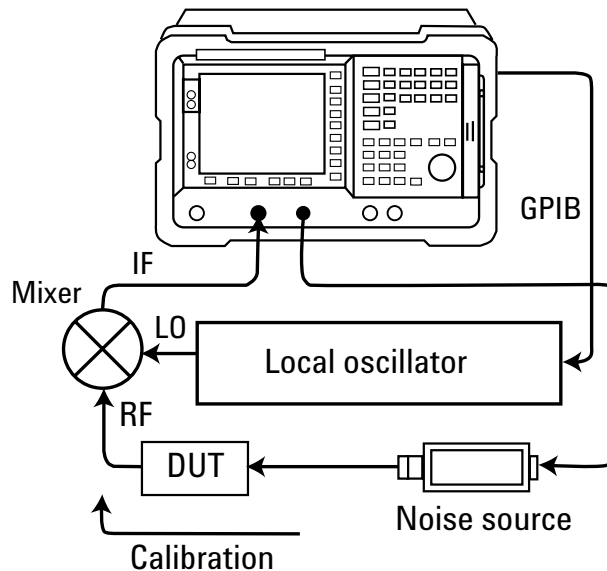

Figure 4. Mixer used as system downconverter

4.1.1.1 Lower sideband (LSB) measurement

Governing equation:

$$LO = RF + IF$$

Setup:

$$f_{\text{START}} = 200 \text{ MHz}$$

$$f_{\text{STOP}} = 290 \text{ MHz}$$

$$f_{\text{FIF}} = 10 \text{ MHz}$$

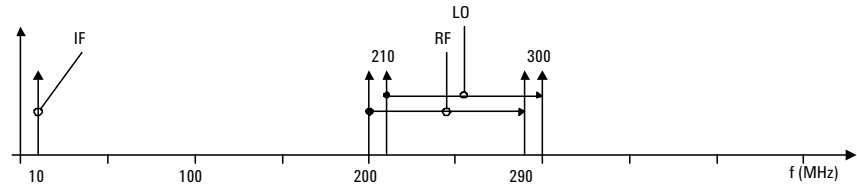

The NFA determines that the external LO must be swept from 210 to 300 MHz. The RF frequency is always below the LO frequency so the lower sideband is selected (assuming filtering of the corresponding upper sideband).

Restrictions:

- Frequency range limits

$$f_{\text{START}} = f_{\text{LO(MIN)}} - f_{\text{FIF}}$$

$$f_{\text{STOP}} = f_{\text{LO(MAX)}} - f_{\text{FIF}}$$

- $f_{\text{RF(START)}} > f_{\text{FIF}}$

If this restriction is broken, error 305 (“Mode setup error;Start freq must be greater than fixed IF freq”) will be generated. To resolve this error condition, decrease f_{FIF} or increase $f_{\text{RF(START)}}$.

4.1.1.2 Upper sideband (USB) measurement

Governing equation:

$$LO = RF - IF$$

Setup:

$$f_{\text{START}} = 200 \text{ MHz}$$

$$f_{\text{STOP}} = 290 \text{ MHz}$$

$$f_{\text{FIF}} = 10 \text{ MHz}$$

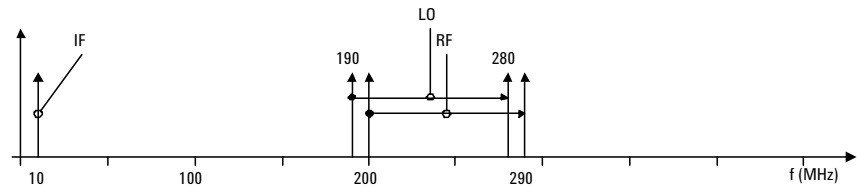

The NFA determines that the external LO must be swept from 190 to 280 MHz. The RF frequency is always above the LO frequency so the upper sideband is selected (assuming filtering of the corresponding lower sideband).

Restrictions:

- Frequency range limits

$$f_{\text{START}} = f_{\text{LO(MIN)}} + f_{\text{FIF}}$$

$$f_{\text{STOP}} = f_{\text{LO(MAX)}} + f_{\text{FIF}}$$

- $f_{\text{LO(START)}} > f_{\text{FIF}}$

If this restriction is broken, error 305 ("Mode setup error; Start LO freq must be greater than fixed IF freq") will be generated. To resolve this error condition, decrease f_{FIF} or increase $f_{\text{RF(START)}}$.

4.1.1.3 DSB measurement

Governing equation:

$$LO = RF$$

Setup:

$$f_{\text{START}} = 200 \text{ MHz}$$

$$f_{\text{STOP}} = 290 \text{ MHz}$$

$$f_{\text{FIF}} = 10 \text{ MHz}$$

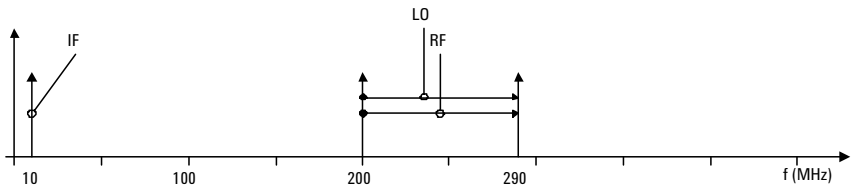

The NFA determines that the external LO must be swept from 200 to 290 MHz. The RF frequency is always the same as the LO frequency so both the upper and lower sidebands are selected (assuming no filtering of either sideband).

Restrictions:

- Frequency range limits

$$f_{\text{START}} = f_{\text{LO(MIN)}}$$

$$f_{\text{STOP}} = f_{\text{LO(MAX)}}$$

- $f_{\text{RF(START)}} > f_{\text{FIF}}$

If this restriction is broken, error 305 (“Mode setup error;Start freq must be greater than fixed IF freq”) will be generated. To resolve this error condition, decrease f_{FIF} or increase $f_{\text{RF(START)}}$.

4.1.2 Variable frequency IF and fixed LO

The GPIB connection between the LO and the NFA is optional. The NFA can control the LO if required, or the LO can be controlled manually. A SSB filter is shown in Figure 5 because it is used to filter the unwanted sideband.

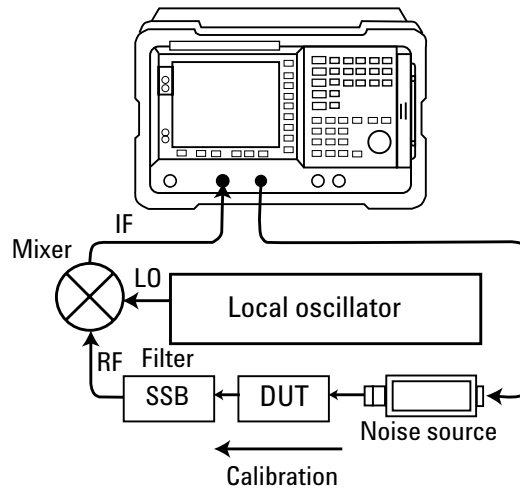

Figure 5. Mixer used as system downconverter with fixed LO and without GPIB control

The user specifies input frequencies to the NFA as RF (input to DUT) frequencies. The RF frequencies are also the ENR lookup frequencies. User calibration takes place at the RF frequencies and is performed with the noise source connected directly to the mixer RF input port and includes the filter. This measurement is equivalent to 8970B mode 1.2.

DSB measurements are not possible with the NFA when performing amplifier mode measurements using a swept IF.

4.1.2.1 LSB measurement

Governing equation:

$$IF = LO - RF$$

Setup:

$$f_{START} = 200 \text{ MHz}$$

$$f_{STOP} = 290 \text{ MHz}$$

$$f_{FLO} = 300 \text{ MHz}$$

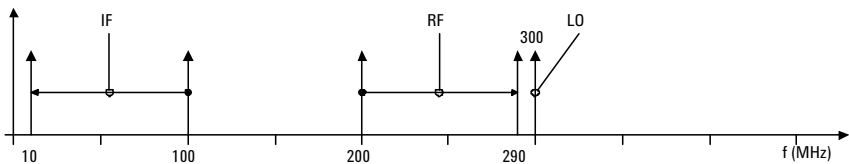

The NFA determines that the IF (tuned frequency of the NFA) must be swept from 100 to 10 MHz. The RF frequency is always below the LO frequency so the lower sideband is selected (assuming filtering of the corresponding upper sideband).

Restrictions:

- Frequency range limits

$$f_{START} = f_{SIF(MIN)}$$

$$f_{STOP} = f_{LO(MAX)} - f_{SIF(MIN)}$$

- $f_{RF(STOP)} < f_{FLO}$

If this restriction is broken, error 305 (“Mode setup error;Stop freq must be less than fixed LO freq”) will be generated. To resolve this error condition, increase f_{FLO} or decrease $f_{RF(STOP)}$.

- $f_{RF(START)} > f_{IF(START)}$

If this restriction is broken, error 305 (“Mode setup error;Start freq must be greater than start IF freq”) will be generated. To resolve this error condition, decrease f_{FLO} or increase $f_{RF(START)}$.

- $f_{FLO} - f_{RF(STOP)} > f_{SIF(MIN)}$

If this restriction is broken, error 305 (“Mode setup error;LO – Stop freq must be \geq min system input freq”) will be generated. To resolve this error condition, increase f_{FLO} or decrease $f_{RF(STOP)}$.

4.1.2.2 USB measurement

Governing equation:

$$IF = RF - LO$$

Setup:

$$f_{\text{START}} = 310 \text{ MHz}$$

$$f_{\text{STOP}} = 400 \text{ MHz}$$

$$f_{\text{FLO}} = 300 \text{ MHz}$$

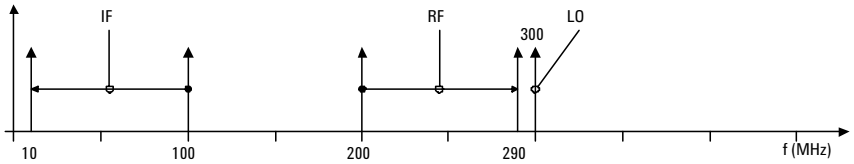

The NFA determines that the IF (tuned frequency of the NFA) must be swept from 10 to 100 MHz. The RF frequency is always above the LO frequency so the upper sideband is selected (assuming filtering of the corresponding lower sideband).

Restrictions:

- Frequency range limits

$$f_{\text{RF(MIN)}} = f_{\text{LO(MIN)}} + f_{\text{SIF(MIN)}}$$

$$f_{\text{RF(MAX)}} = f_{\text{LO(MAX)}}$$

- $f_{\text{RF(START)}} > f_{\text{FLO}}$

If this restriction is broken, error 305 (“Mode setup error;Start freq must be greater than fixed LO freq”) will be generated. To resolve this error condition, decrease f_{FLO} or increase $f_{\text{RF(START)}}$.

- $f_{\text{IF(STOP)}} < f_{\text{FLO}}$

If this restriction is broken, error 305 (“Mode setup error;Stop IF freq must be less than fixed LO freq”) will be generated. To resolve this error condition, increase f_{FLO} or decrease $f_{\text{RF(STOP)}}$.

- $f_{\text{RF(START)}} - f_{\text{FLO}} > f_{\text{SIF(MIN)}}$

If this restriction is broken, error 305 (“Mode setup error;Start – LO freq must be \geq min system input freq”) will be generated. To resolve this error condition, decrease f_{FLO} or increase $f_{\text{RF(START)}}$.

4.2 Downconverter mode

No system downconversion is required because the DUT performs frequency conversion. The DUT measurement frequency can be within the normal operating range for the NFA. The test setup is shown in Figure 6.

4.2.1 Variable frequency LO and fixed IF

The LO must be connected to the LO GPIB port on the rear panel of the NFA as shown in Figure 6. The user specifies input frequencies to the NFA as RF (input to DUT) frequencies. The RF frequencies are the ENR lookup frequencies. User calibration is required only at fixed IF. User calibration is carried out without the DUT. The DUT is then replaced and measurements can be made. Additional filtering may be required for SSB measurements. This measurement is equivalent to 8970B mode 1.3.

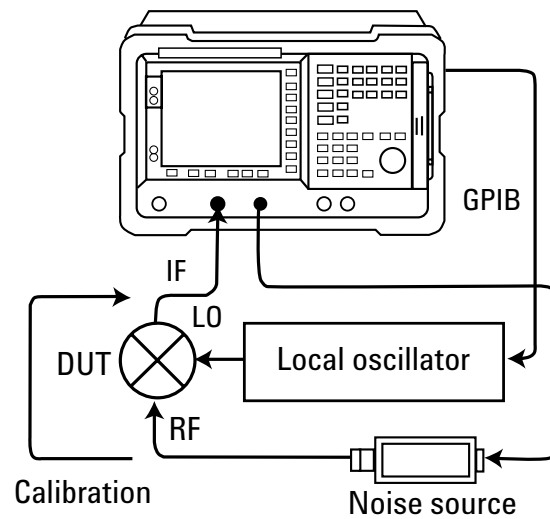

Figure 6. Downconverter mode measurement setup

4.2.1.1 LSB measurement

Governing equation:

$$LO = RF + IF$$

Setup:

$$f_{\text{START}} = 200 \text{ MHz}$$

$$f_{\text{STOP}} = 290 \text{ MHz}$$

$$f_{\text{FIF}} = 10 \text{ MHz}$$

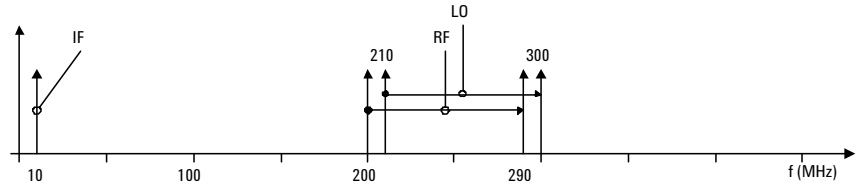

The NFA determines that the external LO must be swept from 210 to 300 MHz. The RF frequency is always below the LO frequency so the lower sideband is selected (assuming filtering of the corresponding upper sideband).

Restrictions:

- Frequency range limits

$$f_{\text{START}} = f_{\text{LO(MIN)}} - f_{\text{FIF}}$$

$$f_{\text{STOP}} = f_{\text{LO(MAX)}} - f_{\text{FIF}}$$

- $f_{\text{RF(START)}} > f_{\text{FIF}}$

If this restriction is broken, error 305 (“Mode setup error;Start freq must be greater than fixed IF freq”) will be generated. To resolve this error condition, decrease f_{FIF} or increase $f_{\text{RF(START)}}$.

4.2.1.2 USB measurement

Governing equation:

$$LO = RF - IF$$

Setup:

$$f_{\text{START}} = 200 \text{ MHz}$$

$$f_{\text{STOP}} = 290 \text{ MHz}$$

$$f_{\text{FIF}} = 10 \text{ MHz}$$

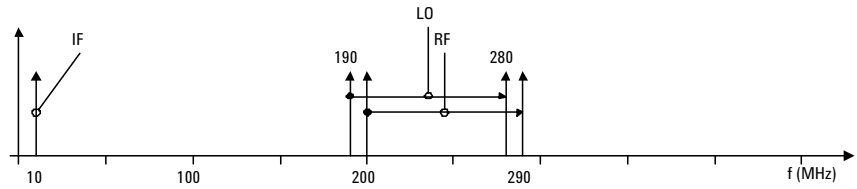

The NFA determines that the external LO must be swept from 190 to 280 MHz. The RF frequency is always above the LO frequency so the upper sideband is selected (assuming filtering of the corresponding lower sideband).

Restrictions:

- Frequency range limits

$$f_{\text{START}} = f_{\text{LO(MIN)}} + f_{\text{FIF}}$$

$$f_{\text{STOP}} = f_{\text{LO(MAX)}} + f_{\text{FIF}}$$

- $f_{\text{LO(START)}} > f_{\text{FIF}}$

If this restriction is broken, error 305 ("Mode setup error;Start LO freq must be greater than fixed IF freq") will be generated. To resolve this error condition, decrease f_{FIF} or increase $f_{\text{RF(START)}}$.

4.2.1.3 DSB measurement

Governing equation:

$$LO = RF$$

Setup:

$$f_{\text{START}} = 200 \text{ MHz}$$

$$f_{\text{STOP}} = 290 \text{ MHz}$$

$$f_{\text{FIF}} = 10 \text{ MHz}$$

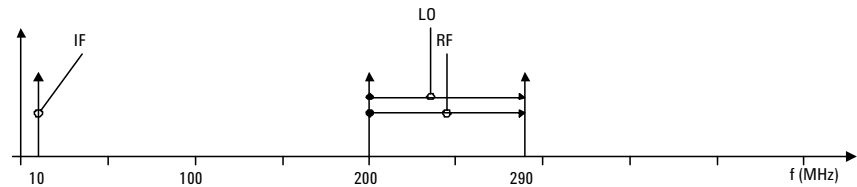

The NFA determines that the external LO must be swept from 200 to 290 MHz. The RF frequency is always the same as the LO frequency so both the upper and lower sidebands are selected.

Restrictions:

- Frequency range limits

$$f_{\text{START}} = f_{\text{LO(MIN)}}$$

$$f_{\text{STOP}} = f_{\text{LO(MAX)}}$$

- $f_{\text{RF(START)}} > f_{\text{FIF}}$

If this restriction is broken, error 305 (“Mode setup error;Start freq must be greater than fixed IF freq”) will be generated. To resolve this error condition, decrease f_{FIF} or increase $f_{\text{RF(START)}}$.

4.2.2 Variable frequency IF and fixed LO

The measurement setup is shown in Figure 7. The GPIB connection between the LO and the NFA is optional. The NFA can control the LO if required, or the LO can be controlled manually. The RF frequencies are the ENR lookup frequencies. User calibration is required at specified IF frequencies. Additional filtering may be required for SSB measurements (a SSB filter is shown in Figure 7). This measurement is equivalent to 8970B mode 1.4.

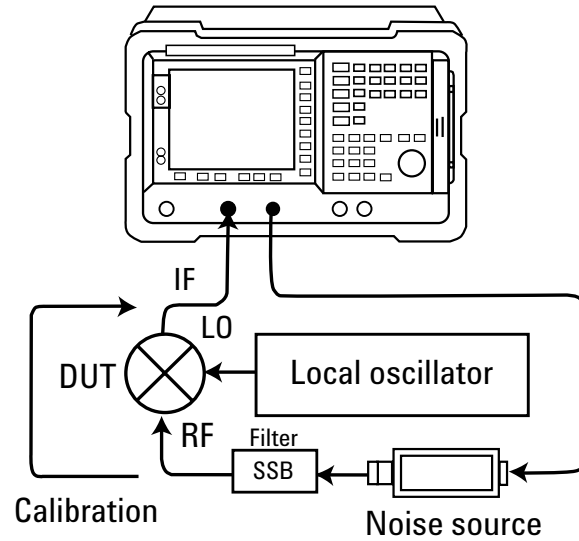

Figure 7. Downconverter mode fixed LO swept IF

The user specifies input frequencies to the NFA as IF (output from DUT) frequencies.

4.2.2.1 LSB measurement

Governing equation:

$$RF = LO - IF$$

Setup:

$$f_{\text{START}} = 10 \text{ MHz}$$

$$f_{\text{STOP}} = 100 \text{ MHz}$$

$$f_{\text{FLO}} = 300 \text{ MHz}$$

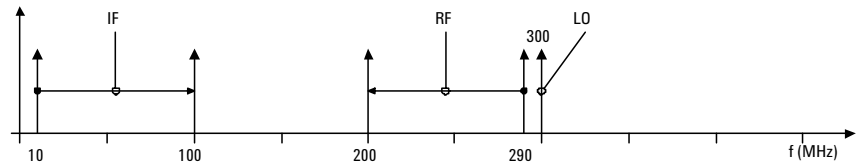

The NFA determines that the ENR lookup frequencies run from 290 to 200 MHz (as the IF is swept from 10 to 100 MHz). The RF frequency is always below the LO frequency so the lower sideband is selected (assuming filtering of the corresponding upper sideband).

Restrictions:

- Frequency range limits

$$f_{\text{START}} = f_{\text{SIF(MIN)}}$$

$$f_{\text{STOP}} = f_{\text{SIF(MAX)}}$$

- $f_{\text{IF(STOP)}} < f_{\text{RF(STOP)}}$

If this restriction is broken, error 305 (“Mode setup error; Stop freq must be less than stop RF freq”) will be generated. To resolve this error condition, increase f_{FLO} or decrease $f_{\text{IF(STOP)}}$.

4.2.2.2 USB measurement

Governing equation:

$$RF = LO + IF$$

Setup:

$$f_{\text{START}} = 10 \text{ MHz}$$

$$f_{\text{STOP}} = 100 \text{ MHz}$$

$$f_{\text{FLO}} = 300 \text{ MHz}$$

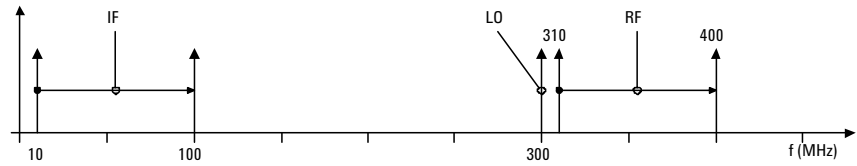

The NFA determines that the ENR lookup frequencies run from 310 to 400 MHz (as the IF is swept from 10 to 100 MHz). The RF frequency is always above the LO frequency so the upper sideband is selected (assuming filtering of the corresponding upper sideband).

Restrictions:

- Frequency range limits

$$f_{\text{START}} = f_{\text{SIF(MIN)}}$$

$$f_{\text{STOP}} = f_{\text{SIF(MAX)}}$$

- $f_{\text{IF(STOP)}} < f_{\text{FLO}}$

If this restriction is broken, error 305 (“Mode setup error; Stop freq must be less than fixed LO freq”) will be generated. To resolve this error condition, increase f_{FLO} or decrease $f_{\text{IF(STOP)}}$.

4.2.2.3 DSB measurement

Governing equation:

$$RF = LO$$

Setup:

$$f_{\text{START}} = 10 \text{ MHz}$$

$$f_{\text{STOP}} = 100 \text{ MHz}$$

$$f_{\text{FLO}} = 300 \text{ MHz}$$

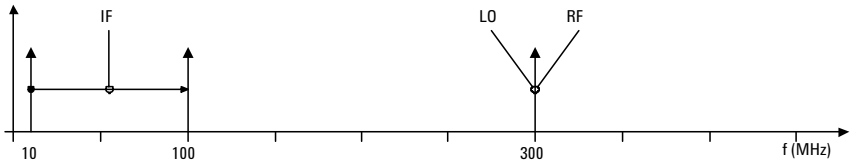

The NFA determines that the ENR lookup frequency is fixed at 300 MHz (as the IF is swept from 10 to 100 MHz). The RF frequency is always the same as the LO frequency so both the upper and lower sidebands are selected (assuming no filtering of either sideband).

Restrictions:

- Frequency range limits

$$f_{\text{START}} = f_{\text{SIF(MIN)}}$$

$$f_{\text{STOP}} = f_{\text{SIF(MAX)}}$$

- $f_{\text{IF(STOP)}} < f_{\text{RF(STOP)}}$

If this restriction is broken, error 305 (“Mode setup error; Stop freq must be less than stop RF freq”) will be generated. To resolve this error condition, increase f_{FLO} or decrease $f_{\text{IF(STOP)}}$.

4.3 Upconverter mode

Upconverter measurements were possible with the 8970B. However, there were limitations and the NFA eliminates some of them. The user interface provides a choice of upconverter and both LSB and USB are supported while the 8970B supported only USB.

The NFA refers to the input frequency to an upconverting device as RF and the output frequency from an upconverting device as IF.

DSB measurements are not possible with the NFA when performing measurements using the upconverter mode.

4.3.1 Variable frequency LO and fixed IF

The LO must be connected to the LO GPIB port on the rear panel of the NFA. The user specifies input frequencies to the NFA as RF (input to DUT) frequencies. The RF frequencies are the ENR lookup frequencies. User calibration is required only at fixed IF. The test setup is shown in Figure 8.

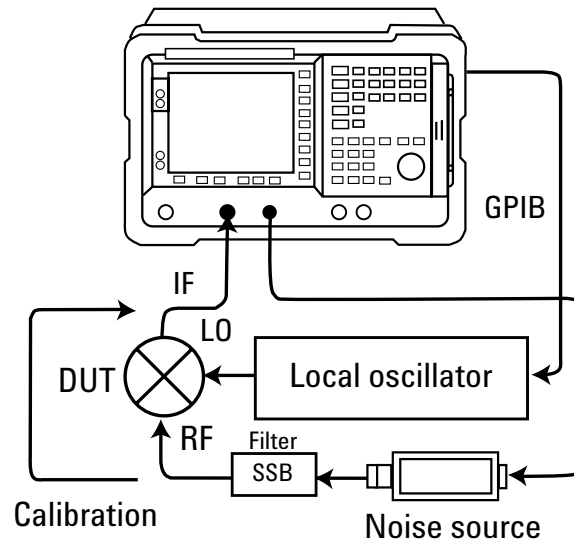

Figure 8. Upconverter measurement

User calibration is performed without the DUT. The DUT is then replaced and measurements can be made. Filtering is required, because only SSB measurements are possible. If sideband is USB, this measurement is equivalent to 8970B mode 1.3 with SUM sideband.

4.3.1.1 LSB measurement

Governing equation:

$$LO = RF + IF$$

Setup:

$$f_{\text{START}} = 10 \text{ MHz}$$

$$f_{\text{STOP}} = 100 \text{ MHz}$$

$$f_{\text{FIF}} = 300 \text{ MHz}$$

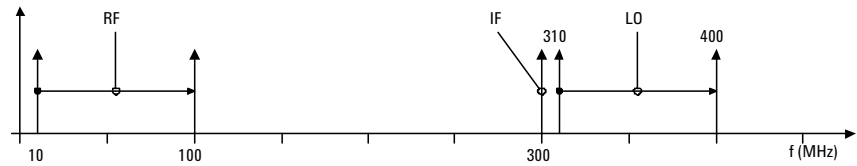

The NFA determines that the external LO must be swept from 310 to 400 MHz. The IF frequency is always below the LO frequency so the lower sideband is selected (assuming filtering of the corresponding upper sideband).

Restrictions:

- Frequency range limits

$$f_{\text{START}} = f_{\text{UPCRF(MIN)}} \text{ (Upconverter minimum RF frequency. Here, 1 Hz)}$$

$$f_{\text{STOP}} = f_{\text{SIF(MAX)}}$$

- $f_{\text{RF(STOP)}} < f_{\text{FIF}}$

If this restriction is broken, error 305 (“Mode setup error; Stop freq must be less than fixed IF freq”) will be generated. To resolve this error condition, increase f_{FIF} or decrease $f_{\text{RF(STOP)}}$.

4.3.1.2 USB measurement

Governing equation:

$$LO = IF - RF$$

Setup:

$$f_{\text{START}} = 10 \text{ MHz}$$

$$f_{\text{STOP}} = 100 \text{ MHz}$$

$$f_{\text{FIF}} = 300 \text{ MHz}$$

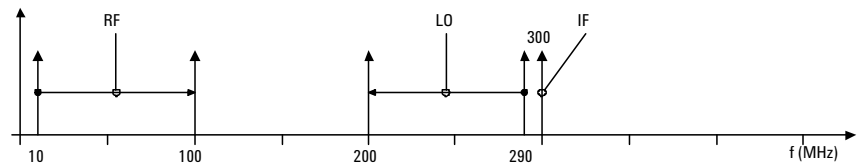

The NFA determines that the external LO must be swept from 290 to 200 MHz. The IF frequency is always above the LO frequency so the upper sideband is selected (assuming filtering of the corresponding lower sideband).

Restrictions:

- Frequency range limits

$$f_{\text{START}} = f_{\text{UPCRF(MIN)}} \text{ (Upconverter minimum RF frequency. Here, 1 Hz)}$$

$$f_{\text{STOP}} = f_{\text{SIF(MAX)}}$$

- $f_{\text{RF(STOP)}} < f_{\text{LO(STOP)}}$

If this restriction is broken, error 305 (“Mode setup error; Stop freq must be less than stop LO freq”) will be generated. To resolve this error condition, increase f_{FIF} or decrease $f_{\text{RF(STOP)}}$.

4.3.2 Variable frequency IF and fixed LO

The GPIB connection between the LO and the NFA is optional. The NFA can control the LO if required, or the LO can be controlled manually as shown in Figure 9. The RF frequencies are the ENR lookup frequencies. User calibration is required at specified IF frequencies.

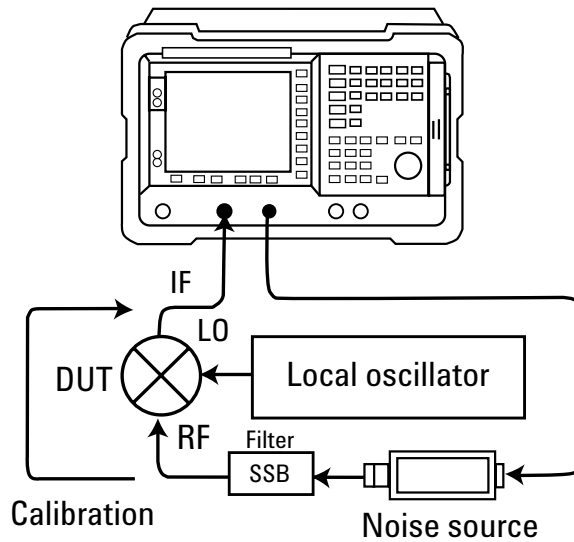

Figure 9. LO controlled manually

User calibration is performed without the DUT. The DUT is then replaced and measurements can be made. Filtering is required because only SSB measurements are possible. If sideband is USB, this measurement is equivalent to 8970B mode 1.4 with SUM sideband.

The user specifies input frequencies to the NFA as IF (output from DUT) frequencies.

4.3.2.1 LSB measurement

Governing equation:

$$RF = LO - IF$$

Setup:

$$f_{\text{START}} = 200 \text{ MHz}$$

$$f_{\text{STOP}} = 290 \text{ MHz}$$

$$f_{\text{FLO}} = 300 \text{ MHz}$$

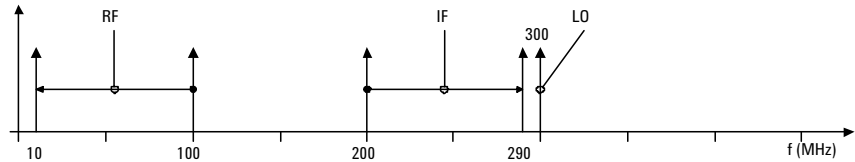

The NFA determines that the ENR lookup frequency is swept from 100 to 10 MHz (as the IF is swept from 200 to 290 MHz). The IF frequency is always below the LO frequency so the lower sideband is selected (assuming filtering of the corresponding upper sideband).

Restrictions:

- Frequency range limits

$$f_{\text{START}} = f_{\text{SIF(MIN)}}$$

$$f_{\text{STOP}} = f_{\text{LO(MAX)}} - f_{\text{UPCRF(MIN)}}$$

- $f_{\text{IF(STOP)}} < f_{\text{FLO}}$

If this restriction is broken, error 305 (“Mode setup error; Stop freq must be less than fixed LO freq”) will be generated. To resolve this error condition, increase f_{FLO} or decrease $f_{\text{IF(STOP)}}$.

- $f_{\text{IF(START)}} > f_{\text{RF(START)}}$

If this restriction is broken, error 305 (“Mode setup error; Start freq must be greater than start RF freq”) will be generated. To resolve this error condition, decrease f_{FLO} or increase $f_{\text{IF(START)}}$.

4.3.2.2 USB measurement

Governing equation:

$$RF = IF - LO$$

Setup:

$$f_{\text{START}} = 310 \text{ MHz}$$

$$f_{\text{STOP}} = 400 \text{ MHz}$$

$$f_{\text{FLO}} = 300 \text{ MHz}$$

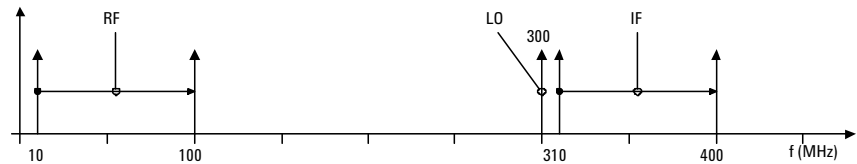

The NFA determines that the ENR lookup frequency is swept from 10 to 100 MHz (as the IF is swept from 310 to 400 MHz). The IF frequency is always above the LO frequency so the upper sideband is selected (assuming filtering of the corresponding lower sideband).

Restrictions:

- Frequency range limits

$$f_{\text{START}} = f_{\text{LO(MIN)}} + f_{\text{UPCRF(MIN)}}$$

$$f_{\text{STOP}} = f_{\text{SIF(MAX)}}$$

- $f_{\text{IF(START)}} > f_{\text{FLO}}$

If this restriction is broken, error 305 (“Mode setup error;Start freq must be greater than fixed LO freq”) will be generated. To resolve this error condition, decrease f_{FLO} or increase $f_{\text{IF(START)}}$.

- $f_{\text{RF(STOP)}} < f_{\text{FLO}}$

If this restriction is broken, error 305 (“Mode setup error;Stop RF freq must be less than fixed LO freq”) will be generated. To resolve this error condition, increase f_{FLO} or decrease $f_{\text{IF(STOP)}}$.

5.0 Measurement Examples

The measurement examples shown here use the following terminology when relating to the NFA. All commands appearing in bold squared brackets relate to hard key presses e.g., [**Hard Key**]. All commands appearing in bold curly brackets relate to soft key presses e.g. {**Soft Key**}. All other statements appearing in bold relate to display settings or values, e.g., **Bold Text**.

5.1 Amplifier mode measurements using N8975A option K40

The N8975A option K40 block downconverter is designed to be used with the N8975A NFA. The K40 extends the upper measurement frequency of the NFA from 26.5 to 40 GHz. The downconverter uses an internal 44.5 GHz LO to downconvert the input signal to an IF that is within the measurement range of the NFA.

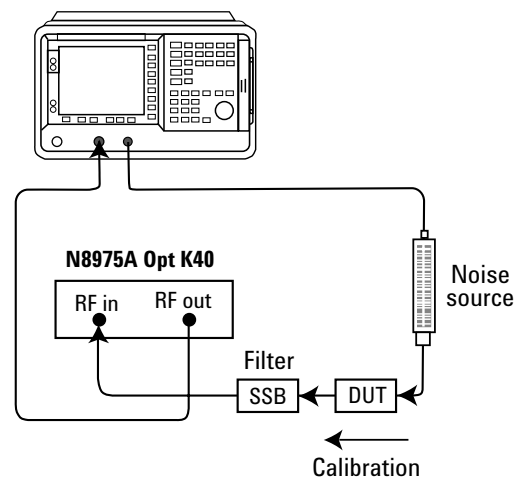

Figure 10. N8975A as system downconverter

The measurement setup is shown in Figure 10. The K40 has its own internal LO, so a fixed LO and swept IF measurement is required. The NFA cannot control the LO so no GPIB connection is required.

In this example, an LSB measurement is performed on a DUT between 28 and 34 GHz at every 250 MHz (25 measurement points). The noise source must have an operating frequency range that covers 28 to 34 GHz so an Agilent 346C K01 (1 to 50 GHz) or an Agilent R347B (26.5 to 40 GHz) should be used. User calibration takes place without the DUT, but with the SSB filter and K40.

5.1.1 NFA setup instructions

1. Switch on the N8975A and the K40 and allow one hour to warm up.
2. Ensure the preset on the NFA is set to factory settings, press **[System]**, **{More}**, **{Power On/Preset}** make sure **{Power On}** is set to **Preset** and **{Preset}** is set to **Factory**.
3. Press **[Preset]** and wait for the routine to finish.
4. Load the ENR table for the noise source being used.
5. Press **[System]** then **{External LO}** then set the **{Max Freq}** to **[5] [0]** using the numeric keypad and select **{GHz}**.
6. Press **[Meas Mode]** then **{Amplifier}** if Amplifier is not already selected.
The NFA display will show “Mode setup error, start freq must be greater than start IF freq”.
7. Press **[Tab]** to highlight System Downconverter and switch this to **{On}**.
8. Set the LO Mode to **{Fixed}**.
9. Press **[Mode Setup]** and use **[Tab]** to select LO Frequency if this is not already selected
10. Enter the LO frequency of **[4] [4] [.] [5]** using the numeric keypad and select **{GHz}**.
11. Set Sideband to **{LSB}**. LO Control should be **{Off}** and leave the External LO Power Level set to **{0.000 dBm}**.
12. The governing equation for this measurement is $IF=LO-RF$. The frequency map is shown in Figure 11.

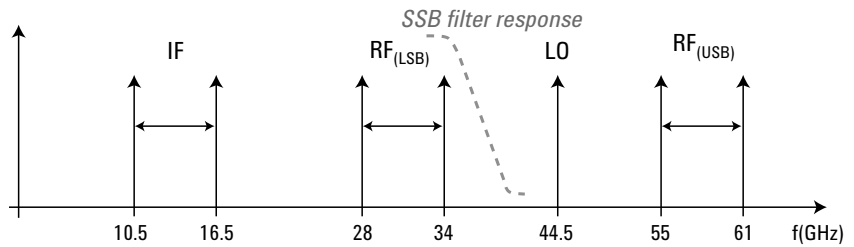

Figure 11. Frequency map

The frequency map shows that the NFA will be set to sweep from 28 to 34 GHz but will tune from 10.5 to 16.5 GHz. The frequency map shows that a 35 GHz low-pass filter would be sufficient to filter out the unwanted sideband.

13. Press **[Frequency/Points]** then set **{Start Freq}** to **[2] [8]** using the numeric keypad and select **{GHz}**.
14. Set **{Stop Freq}** to **[3] [4]** using the numeric keypad and select **{GHz}**.
15. Press **{More 1 of 2}** then set **{Points}** to **[2] [1]** using the numeric keypad and press **[Enter]**.
16. Press **[System]** then **{Alignment}** and make sure Alignment is set to On.
17. Set **{Alignmnt Mode}** to Point.

This improves the accuracy of the measurement but reduces measurement speed.

Press **[Averaging/Bandwidth]** and set **{Averages}** to **[3] [2]** using the numeric keypad and press **[Enter]**.

18. Set **{Averaging}** to On.
19. Connect the equipment as shown in Figure 10 (without the DUT).
20. Press **[Calibrate]** twice and wait for calibration to complete.

Replace the DUT in the measuring system after user calibration has completed. Press **[Restart]** to display measurement results.

5.2 Downconverter measurement with variable-LO and fixed IF

For this example the DUT is assumed to be a mixer, the LO is to be swept from 4.7 to 5.2 GHz, the IF is fixed at 1 GHz, the standard number of measurement points is 11, and LSB will be measured. The measurement setup is shown in Figure 12.

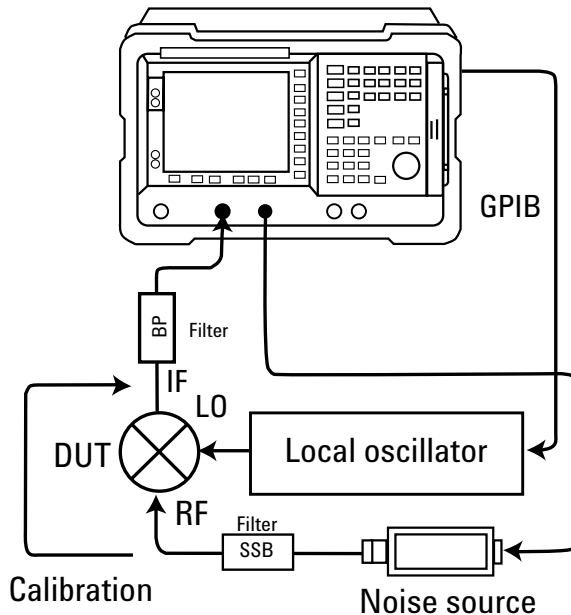

Figure 12. Variable LO and fixed IF with filtering

The GPIB connection is required because the NFA will control the LO (the LO is assumed to be configured for use). The SSB filter is required to filter the unwanted sideband. The IF is kept at a fixed value during this measurement, so a bandpass filter can be inserted between the DUT and the NFA (if required), to filter out mixer spurious and harmonic signals that can degrade the accuracy of the measurement.

User calibration takes place without the DUT or SSB filter. The noise source is connected directly to the NFA or via the bandpass filter if used. The SSB filter cannot be included in the user calibration because DUT measurement takes place at a different frequency from user calibration. The SSB filter is replaced during DUT measurement. Filter losses must be measured and compensated for using the NFA loss compensation function.

Note:

A loss temperature must be entered when using the NFA loss compensation function.

Any Agilent general-purpose noise source (e.g. 346B/N4001A) can be used for this measurement.

5.2.1 NFA setup instructions

1. Switch on the NFA and allow one hour to warm up.
2. Ensure Preset is set to factory settings, press **[System]**, **{More}**, **{Power On/Preset}** and make sure **{Preset}** is set to Factory.
3. Press **[Preset]** and wait for the routine to finish.
4. Load the ENR table for the noise source being used
5. Press **[Meas Mode]** and select **{Downconv}**.

The NFA display should show 'Mode setup error, stop freq must be less than stop RF freq'.

6. Press **[Tab]** to highlight LO Mode and select **{Variable}**.
7. Press **[Mode Setup]** and enter an IF Frequency of **[1]** using the numeric keypad and select **{GHz}**.
8. Make sure **Sideband** is set to **{LSB}**.
9. Press **[Tab]** to highlight **LO Control** and select **{On}**
10. Press **[Tab]** to highlight **External LO Power Level** set this to **{7.000 dBm}** using the numeric keypad
11. The governing equation for this measurement is $LO=RF+IF$. The frequency map for this measurement is shown in Figure 13.

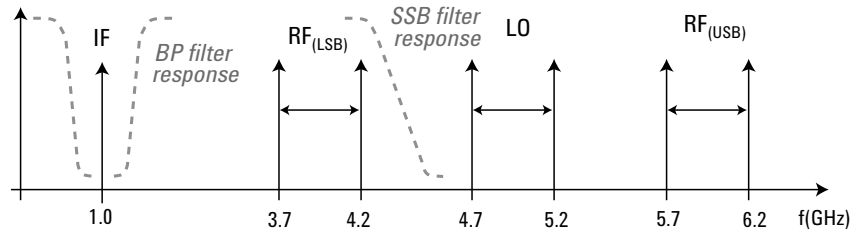

Figure 13. Frequency map

The LSB frequency varies between 3.7 and 4.2 GHz because the LO is swept. These are the measurement frequencies. The frequency map shows that a 4.3-GHz low-pass filter would be sufficient to filter out the unwanted sideband. The bandpass filter would be centered on 1 GHz.

12. Press [**Frequency/Points**] then set {**Start Freq**} to [3] [.] [7] using the numeric keypad and select {**GHz**}.
13. Set {**Stop Freq**} to [4] [.] [2] using the numeric keypad and select {**GHz**}.
14. Press [**System**] then {**Alignment**} and make sure Alignment is set to **On**.
15. Set {**Alignmnt Mode**} to **Point**.

This improves the accuracy of the measurement but reduces measurement speed.

16. Press [**Averaging/Bandwidth**] and set {**Averages**} to [3] [2] using the numeric keypad and press [**Enter**].
17. Set {**Averaging**} to **On**.
18. Connect the equipment as shown in Figure 12 (without the DUT).
19. Press [**Calibrate**] twice and wait for calibration to complete.

Replace the DUT in the measuring system after user calibration has completed. Press [**Restart**] to display measurement results.

5.3 Downconverter measurement with variable IF and fixed LO

For this example the DUT is again assumed to be a mixer, the LO is fixed at 5 GHz, and the DUT operating frequency is from 5.8 to 6.3 GHz, the standard number of measurement points is 11, and this time the USB will be measured. The measurement setup is shown in Figure 14.

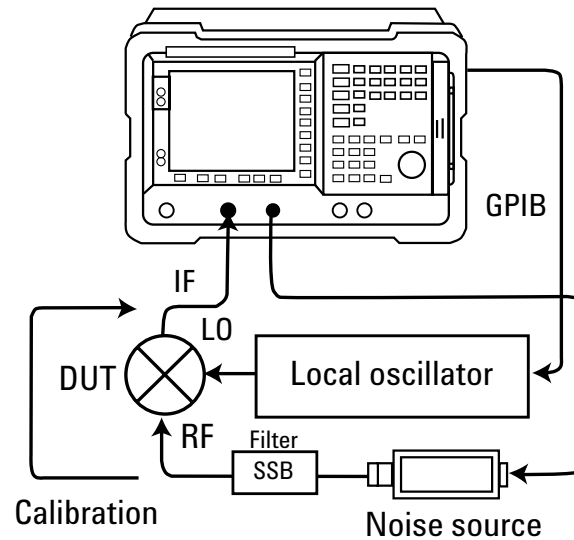

Figure 14. Variable IF and fixed LO with filtering

The GPIB connection is shown because the NFA can still control the LO (assuming the LO has been configured for use) when the LO frequency is fixed. The SSB filter is required to filter the unwanted sideband. A fixed LO is used so the IF must be swept and no band-pass filter can be used.

User calibration takes place without the DUT or SSB filter, and the noise source is connected directly to the NFA. The SSB filter cannot be included in the user calibration because DUT measurement takes place at a different frequency from user calibration. The SSB filter is replaced during DUT measurement. Filter losses must be measured and compensated for using the NFA loss compensation function.

Note:

A loss temperature must be entered when using the NFA loss compensation function.

Any Agilent general-purpose noise source (e.g. 346B/N4001A) can be used for this measurement.

5.3.1 NFA setup instructions

1. Switch on the NFA and allow one hour to warm up.
2. Ensure **Preset** is set to factory settings, press [**System**], [**More**], [**Power On/Preset**] and make sure {**Preset**} is set to **Factory**.
3. Press [**Preset**] and wait for the routine to finish.
4. Load the ENR table for the noise source being used
5. Press [**Meas Mode**] and select {**Downconv**}.

The NFA display should show 'Mode setup error, stop freq must be less than stop RF freq'.

6. Press [**Tab**] to highlight **LO Mode** and select {**Fixed**}.
7. Press [**Mode Setup**] and press [**Tab**] to highlight **LO Frequency**.
8. Enter a **LO Frequency** of [**5**] using the numeric keypad and select {**GHz**}.
9. Press [**Tab**] to highlight **Sideband** and set this to {**USB**}.
10. Press [**Tab**] to highlight **LO Control** and select {**On**}
11. Press [**Tab**] to highlight **External LO Power Level** set this to {**7.000 dBm**} using the numeric keypad
12. The governing equation for this measurement is $RF=LO+IF$. The frequency map for this measurement is shown in Figure 15.

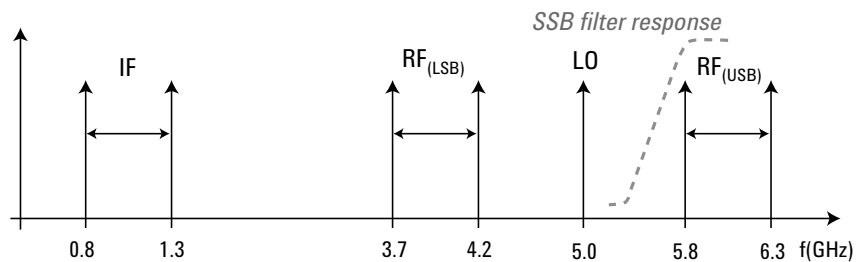

Figure 15. Frequency map

Remember that this measurement evaluates at the IF and in this case the IF varies from 800 MHz to 1.3 GHz as the LO is swept. These are the measurement frequencies.

The frequency map shows that a 5.7-GHz high-pass filter would be sufficient to filter out the unwanted sideband.

13. Press [**Frequency/Points**] then set {**Start Freq**} to [**8**] [**0**] [**0**] using the numeric keypad and select {**MHz**}.
14. Set {**Stop Freq**} to [**1**] [**.**] [**3**] using the numeric keypad and select {**GHz**}.
15. Press [**System**] then {**Alignment**} and make sure **Alignment** is set to **On**
16. Set {**Alignmnt Mode**} to **Point**.
17. Press [**Averaging/Bandwidth**] and set {**Averages**} to [**3**] [**2**] using the numeric keypad and press [**Enter**].
18. Set {**Averaging**} to **On**.
19. Connect the equipment as shown in Figure 14 (without the DUT).
20. Press [**Calibrate**] twice and wait for calibration to complete.

Note:

This improves the accuracy of the measurement but reduces measurement speed.

Replace the DUT in the measuring system after user calibration has completed. Press [**Restart**] to display measurement results.

5.4 Frequency-converting device measurement using two noise sources

The NFA supports the use of two noise sources when performing a DUT measurement. One noise source is used for calibration and a different noise source is used when performing measurements. This is possible because for some measurements (usually frequency-converting DUT's) the NFA user calibration takes place at a different frequency from the DUT measurement.

This feature is used if a noise source that covers both the calibration and measurement range is not available. A N8975A is used to measure a down-converting DUT from 30 to 35 GHz with a fixed IF of 12 GHz as shown in Figure 16.

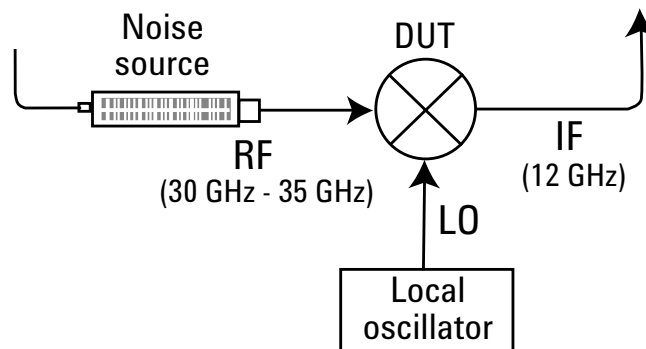

Figure 16. Measuring a downconverting DUT from 30 to 35 GHz

User calibration takes place at 12 GHz with the noise source connected directly to the NFA, so an Agilent N4001A noise source can be used for user calibration. However, DUT measurement takes place between 30 to 35 GHz, which is outside the range for the N4001A. An Agilent R347B noise source (26.5 to 40 GHz) would cover the required frequency range.

5.4.1 NFA setup instructions

1. Switch on the N8975A and allow one hour to warm up.
2. Ensure Preset is set to factory settings, press **[System]**, **{More}**, **{Power On/Preset}**, and make sure **{Preset}** is set to **Factory**.
3. Press **[Preset]** and wait for the routine to finish.
4. Select **ENR** and set **{Common Table}** to **Off**
5. Select Meas Table and enter the ENR table for the noise source used for measurement (e.g. R347B)
6. Select Cal Table and enter the ENR table for the noise source used to perform user calibration (e.g. N4001A)

Note:

If an adapter was required to connect the R347B to the DUT, the adapter losses can be compensated for using the NFA loss compensation function.

Connect the noise source used for user calibration to the NFA when required. When user calibration is complete remove the first noise source and replace with the noise source used for measurement.

6.0 Additional Measurements

This section contains details of additional measurements that are not included in the NFA operating manual.

6.1 LO frequency

Note:

This measurement is only suitable when using a fixed LO that is not controlled by the NFA.

The governing equations for each measurement control the position of the RF, IF, and LO frequencies with respect to one another. Either the RF or IF must always be less than the LO.

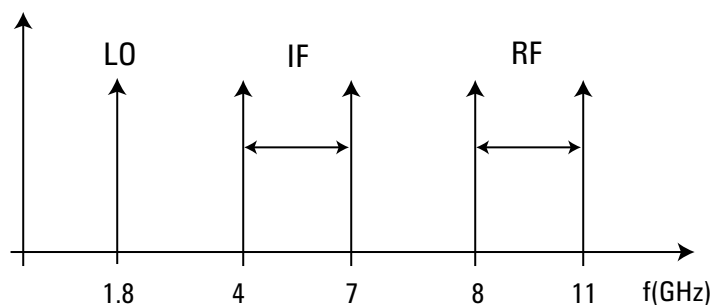

Figure 17. LO frequency measurement

For the example shown in Figure 17, if a measurement was performed on a frequency-downconverting DUT from 8 to 11 GHz using a fixed LO at 1.8 GHz, the governing equations are:

$$\text{RF} = \text{LO} - \text{IF} \text{ (for LSB)}$$

$$\text{RF} = \text{LO} + \text{IF} \text{ (for USB)}$$

This frequency arrangement does not satisfy these equations. To complicate things further the USB measurement has an additional frequency restriction of $f_{\text{IF}(\text{STOP})} < f_{\text{FLO}}$ so it looks like measurement is not possible.

The NFA requires the LO value and sideband selection to calculate the correct RF values. In this case the LO is fixed so it is not controlled by the NFA. For a USB measurement, the LO must be greater than the IF (defined by the frequency restriction shown above), but less than the RF. If an LO value of 7.5 GHz was inserted into the governing equation for the USB measurement:

$$\begin{aligned} \text{RF} &= 7.5 + 4 = 11.5 \text{ GHz} \\ \text{RF} &= 7.5 + 7 = 14.5 \text{ GHz} \end{aligned}$$

If this value is used for the LO the IF frequency could be seen, but the RF is not what is desired.

Similarly:

$$\begin{aligned} 8 &= 7.5 + \text{IF} \geq \text{IF} = 0.5 \text{ GHz} \\ 11 &= 7.5 + \text{IF} \geq \text{IF} = 3.5 \text{ GHz} \end{aligned}$$

If this value of LO is used measurements could be made with the RF desired. However, the IF is not what is desired. There is no way to perform this measurement using USB. If LSB is used, the LO must be greater than the RF. The governing equation is $\text{RF} = \text{LO} - \text{IF}$.

$$\begin{aligned} 11 &= \text{LO} - 4 \geq \text{LO} = 15 \\ 8 &= \text{LO} - 7 \geq \text{LO} = 15 \end{aligned}$$

Therefore, if the NFA is set up using an LO frequency of 15 GHz and LSB is selected, measurements can be made over the desired frequency range as shown in Figure 18.

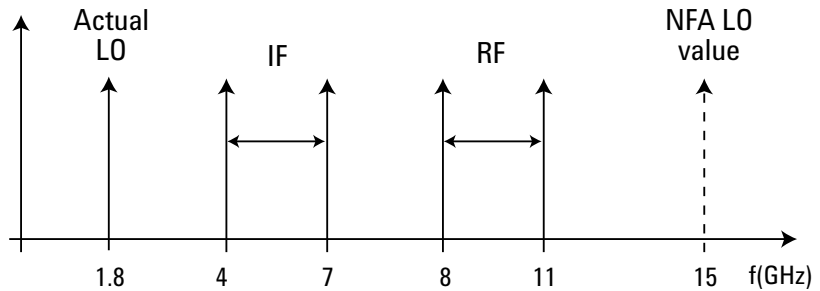

Figure 18. Actual LO frequency vs frequency set by NFA

6.2 Double frequency conversion

Double frequency conversion measurements are not directly supported by the NFA, however, it is possible to perform a double frequency conversion measurement under certain conditions. Figure 19 shows a measurement on a frequency converting DUT. If we assume that the output from the DUT (IF1) is outside the frequency range of the NFA being used, further down-conversion is required to bring the DUT output frequency within the NFA operating range.

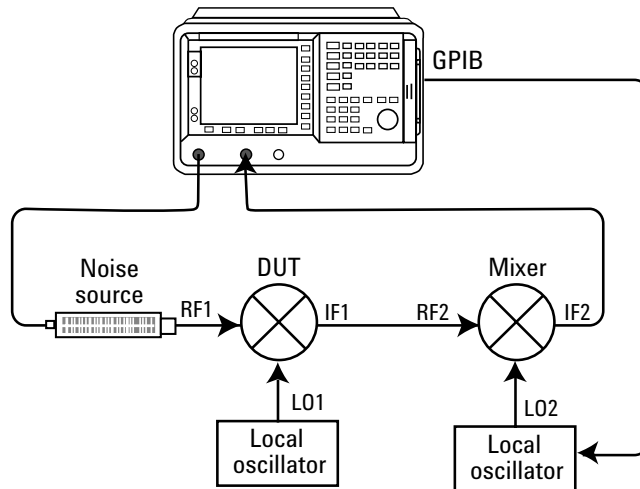

Figure 19. Double frequency conversion

Out of three measurement modes available with the NFA, Amplifier mode is the only mode that can measure a DUT using a system downconverter. This makes it the most suitable mode to use, but this mode assumes the DUT does not perform frequency conversion. If we look at the measurement setup details for Amplifier Mode (given in Section 4.1 of this note), the user specifies input frequencies to the NFA as RF (the input to DUT) frequencies. These frequencies are used by the NFA to determine the correct ENR lookup frequencies. Therefore, by modifying the ENR table used for measurement to take the extra frequency conversion into account it is possible to perform this measurement.

The value of LO1 has to be fixed; LO2 can be controlled by the NFA if required. The value of RF2 is known and IF2 is chosen to be within the operating range of the NFA in use. The Amplifier Mode governing equations (contained in Section 4.1 of this note) can be used to determine sideband selection and the value of LO2. User calibration would be carried out with the DUT removed and the calibration noise source connected directly to the RF input of the second downconversion.

Measurement Example

The DUT in this example is a downconverter. It has an RF of 58GHz, the IF is 5 GHz, and the LO is 63 GHz. The NFA being used is a N8973A therefore further downconversion is required to bring the IF within the operating frequency range of the N8973A.

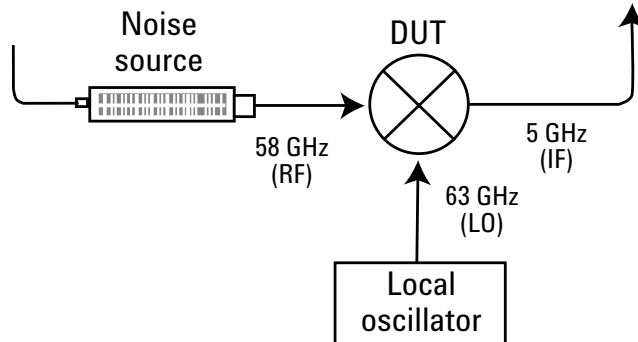

Figure 20. Measurement Example

The governing equation for a Lower Sideband Amplifier Mode measurement using a fixed IF and swept LO (Section 4.1.1.1) is:

$$LO = RF + IF$$

So in this example if we wanted to set the value of IF2 to 2.5 GHz:

$$LO2 = 5 + 2.5 = 7.5 \text{ GHz}$$

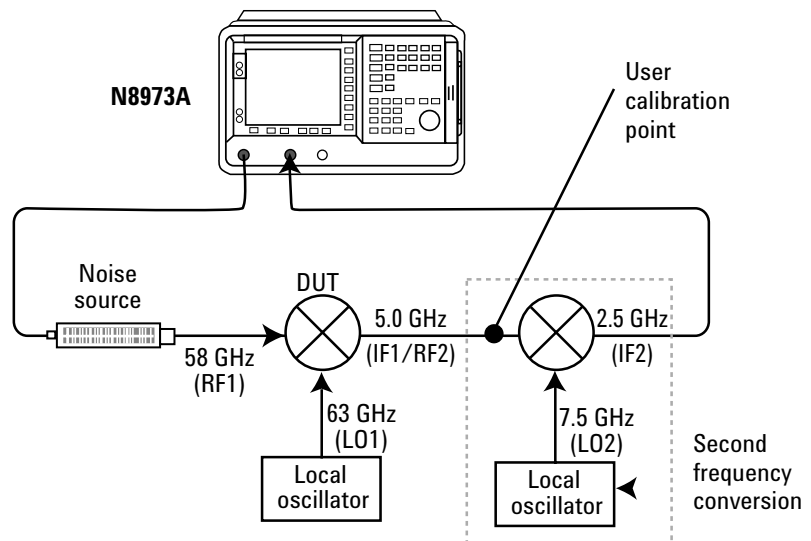

Figure 21. Double conversion measurement setup

NFA setup instructions

1. Switch on the N8973A and allow one hour to warm up.
2. Ensure the preset on the NFA is set to factory settings, press **[System]**, **{More}**, **{Power On/Preset}** make sure **{Power On}** is set to **Preset** and **{Preset}** is set to **Factory**.
3. Press **[Preset]** and wait briefly for the routine to finish.
4. Press **[Meas Mode]** then select **{Amplifier}**.
5. Press **[Tab]** to highlight System Downconverter and switch this to **{On}**.
The NFA display will show "Mode setup error, start freq must be greater than start IF freq", press {ESC} to remove.
6. Set the LO Mode to **{Fixed}**.
7. Press **[Mode Setup]** and use **[Tab]** to select LO Frequency if this is not already selected.
8. Enter the LO frequency of **[7] [.] [5]** Using the numeric keypad and select **{GHz}**.
9. Use **[Tab]** to set sideband to **{LSB}**. LO Control should be **{Off}** and leave the External LO Power Level set to **{0.000 dBm}**.
10. Press **[Frequency/Points]** then set **{Freq Mode}** to **{Fixed}**.
11. Press **{Fixed Freq}** and set the measurement frequency to **[5]** using the numeric keypad and select **{GHz}**.
12. Fixed frequency measurement results can be displayed in Meter Mode by pressing **[Format]** then set **{Format}** to **{Meter}**.

With the large difference in frequency values between RF2 and RF1 it will be assumed that two noise sources are used when performing this measurement. A noise source operating at RF1 (58 GHz) will be required for DUT measurement and a second noise source operating at RF2 (5 GHz) for calibration.

13. Press **[ENR]** and set **{Common Table}** to **{Off}**.
14. Press **[ENR]** then select **{Cal Table}** and create an ENR table for the noise source being used for calibration (5 GHz).
15. Connect the calibration noise source directly to user calibration point shown on Figure 21 and perform a NFA user calibration.

When user calibration is complete the DUT can be added to the measurement system, and the calibration noise source replaced with the measurement noise source. The measurement ENR table has to be configured to take the DUT frequency conversion into account. The NFA expects an ENR table at 5 GHz; however, the correct RF used by the DUT is 58 GHz. Therefore, an entry is created in the ENR table at 5 GHz but uses the ENR value for the measurement noise source at 58 GHz.

Conclusion

This note provides details on the operating modes that are available for the noise figure analyzer and some of the problems that may be encountered when setting up and using the NFA in these modes. The frequency combinations and sideband selections that are allowable have been discussed along with the governing equations used by the NFA in each measurement mode and the restrictions they introduce.

A number of measurement examples have been included based on the most common customer enquires received by Agilent Technologies. These are designed to clarify both the measurement and set up process. If you require further details on a particular application not covered within this application note please contact your local Agilent Technologies contact center for more details.

Appendix A

The following terms are referred to throughout this document:

Term	Denotes
f_{FIF}	Fixed IF frequency
f_{FLO}	Fixed LO frequency
f_{LO}	External LO frequency
f_{SIF}	System input frequency
f_{START}	Start frequency
f_{STOP}	Stop frequency

Appendix B

The upper frequency limit for the NFA series is 26.5 GHz. This can be increased to 110 GHz (in 13.5 GHz bands) using a N8975A K-Series downconverter. The downconverter contains a fixed LO that is 4.5 GHz above or below the specified frequency range. The downconverter translates its specified frequency range down to the frequency band 4.5 to 18 GHz that can then be measured using the N8975A.

Model number	Frequency range (GHz)	Input connector
N8975AZ-K40	26.5 - 40	APC 2.4 mm
N8975AZ-K50	36.5 - 50	APC 2.4 mm
N8975AZ-K63	50 - 63.5	WR15
N8975AZ-K75	61.5 - 75	WR15
N8975AZ-K88	75.0 - 88.5	WR10
N8975AZ-K98	86.5 - 100	WR10
N8975AZ-K99	96.5 - 110	WR10

Note:

A noise source for the frequency band of operation is required.

Agilent Technologies' Test and Measurement Support, Services, and Assistance
Agilent Technologies aims to maximize the value you receive, while minimizing your risk and problems. We strive to ensure that you get the test and measurement capabilities you paid for and obtain the support you need. Our extensive support resources and services can help you choose the right Agilent products for your applications and apply them successfully. Every instrument and system we sell has a global warranty. Support is available for at least five years beyond the production life of the product. Two concepts underlie Agilent's overall support policy: "Our Promise" and "Your Advantage."

Our Promise

Our Promise means your Agilent test and measurement equipment will meet its advertised performance and functionality. When you are choosing new equipment, we will help you with product information, including realistic performance specifications and practical recommendations from experienced test engineers. When you use Agilent equipment, we can verify that it works properly, help with product operation, and provide basic measurement assistance for the use of specified capabilities, at no extra cost upon request. Many self-help tools are available.

Your Advantage

Your Advantage means that Agilent offers a wide range of additional expert test and measurement services, which you can purchase according to your unique technical and business needs. Solve problems efficiently and gain a competitive edge by contracting with us for calibration, extra-cost upgrades, out-of-warranty repairs, and onsite education and training, as well as design, system integration, project management, and other professional engineering services. Experienced Agilent engineers and technicians worldwide can help you maximize your productivity, optimize the return on investment of your Agilent instruments and systems, and obtain dependable measurement accuracy for the life of those products.



Agilent Email Updates

www.agilent.com/find/emailupdates

Get the latest information on the products and applications you select.

Agilent T&M Software and Connectivity

Agilent's Test and Measurement software and connectivity products, solutions and developer network allows you to take time out of connecting your instruments to your computer with tools based on PC standards, so you can focus on your tasks, not on your connections. Visit www.agilent.com/find/connectivity for more information.

By internet, phone, or fax, get assistance with all your test & measurement needs

Phone or Fax

United States:

(tel) 800 452 4844

Canada:

(tel) 877 894 4414

(fax) 905 282 6495

China:

(tel) 800 810 0189

(fax) 800 820 2816

Europe:

(tel) (31 20) 547 2323

(fax) (31 20) 547 2390

Japan:

(tel) (81) 426 56 7832

(fax) (81) 426 56 7840

Korea:

(tel) (82 2) 2004 5004

(fax) (82 2) 2004 5115

Latin America:

(tel) (305) 269 7500

(fax) (305) 269 7599

Taiwan:

(tel) 0800 047 866

(fax) 0800 286 331

Other Asia Pacific Countries:

(tel) (65) 6375 8100

(fax) (65) 6836 0252

Email: tm_asia@agilent.com

Online Assistance:

www.agilent.com/find/assist

Product specifications and descriptions in this document subject to change without notice.

© Agilent Technologies, Inc. 2004

Printed in USA February 6, 2004

5989-0400EN

Footnote: The measurement examples shown in this document use the following terminology when relating to the NFA. All commands appearing in **bold** squared brackets relate to hard key presses e.g., [**Hard Key**]. All commands appearing in **bold** curly brackets relate to soft key presses e.g., {**Soft Key**}. All other statements appearing in bold relate to display settings or values, e.g., **Bold Text**.



Agilent Technologies