

Performance Comparison of Differential and Single-Ended Active Voltage Probes

Application Note 1419-03

Table of Contents

Introduction	1
Bandwidth, Fidelity, and Usability Comparisons	3
Common Mode Rejection Issues	5
Input Loading Comparison	6
Measurement Repeatability	7
Physical Size Considerations	7
Summary	8
Glossary	8
Related Literature	9

Introduction

Previously, if you used high-bandwidth oscilloscopes and active probes, you could choose either single-ended probes or differential probes. You typically used single-ended probes for measuring single-ended signals (a voltage versus ground) and differential probes for measuring differential signals (a plus voltage versus a minus voltage). While it was possible to buy only differential probes and use them to measure both differential and single-ended signals, for practical reasons, most people did not. Differential probes were typically more expensive and harder to use, and had less bandwidth than single-ended probes.

The Agilent InfiniiMax probe system allows either differential or single-ended probing and largely eliminates past objections to differential probes. The new probe system uses interchangeable probe heads that are optimized for hand browsing, plug-on socket connections, or solder-in connections.

With this new probing approach, you need to decide whether to use a differential probe or a single-ended probe for measuring single-ended signals. To make the best decision, you need to examine the performance and usability trade-offs between differential and single-ended probes.

This application note explores performance and usability trade-offs for differential and single-ended probes across several dimensions:

- bandwidth, fidelity, and usability
- common mode rejection
- input loading
- measurement repeatability
- physical size



Single-Ended Probe Model

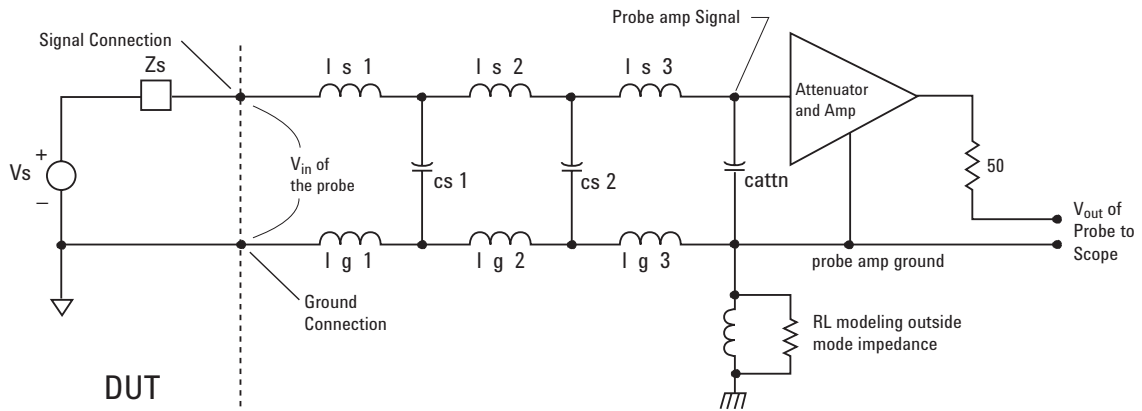

Differential Probe Model

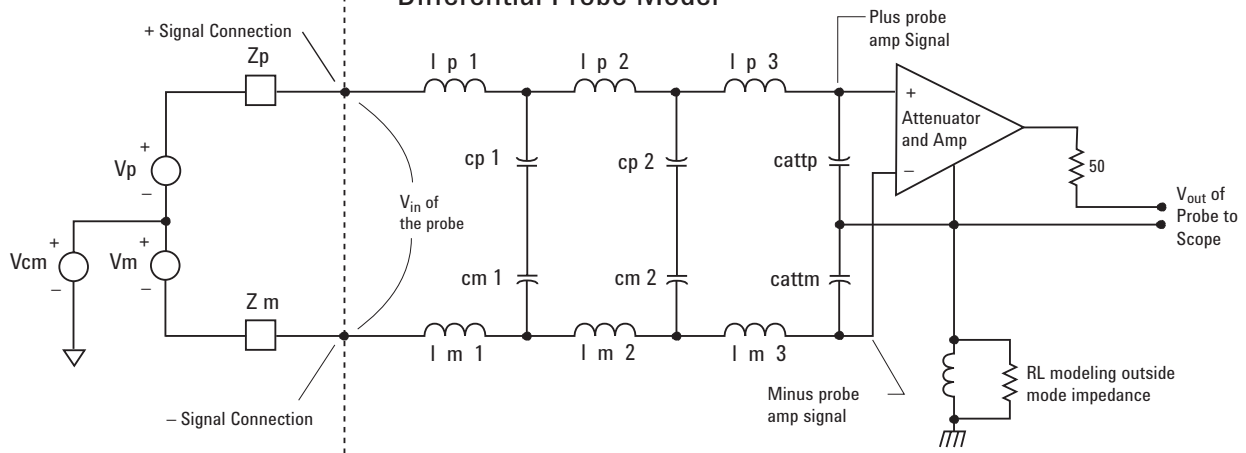

Figure 1. Simplified models of differential and single-ended probes

To assist with our comparisons, we will use simplified models (Figure 1) and measured data from the Agilent 1134A 7 GHz probe amp with solder-in differential and solder-in single-ended probe heads. These two probe heads have very similar physical connection geometries, so the main difference in performance between them will be due to the differential

versus single-ended topologies. These probes are shown in Figures 2 and 3.

To measure probe performance, we used an Agilent E2655A deskew/performance-verification fixture, an Agilent 8720A 20 GHz vector network analyzer and an Agilent Infiniium DCA sampling oscilloscope.

Bandwidth, Fidelity, and Usability Comparisons

As mentioned earlier, single-ended probes traditionally have had higher bandwidth than differential probes. But is this true because of some fundamental law of physics or just because of the practical realities of implementing a differential architecture?

To explore this question, consider the simplified model of connection parasitics for both a differential and single-ended probe, as shown in Figure 1. Since the physical geometries are similar between the single-ended and differential probe heads, the values of the inductors and capacitors will be similar. The ground connection inductance (l_g) values of the single-ended probe can be reduced somewhat – but not dramatically – if the ground connection uses a wide, flat conductor (a “blade”). Note that the differential probe has a tip resistor on both inputs and the single-ended probe has a tip resistor on the signal input and no resistor in the ground wire (zero ohm resistor in actual probe). These resistors are needed to properly damp the resonance caused by the inductors (L_s) and capacitors (C_s) of the input connection. See Agilent Application Note 1404, “The Truth About the Fidelity of High-Bandwidth Voltage Probes,” for further information on this topic.

Analysis of the single-ended model shows that the bandwidth is determined by the values of the inductors and capacitors, and that the ground inductors



Figure 2. Agilent 1134A single-ended solder-in probe head (top), and differential solder-in probe head (bottom)

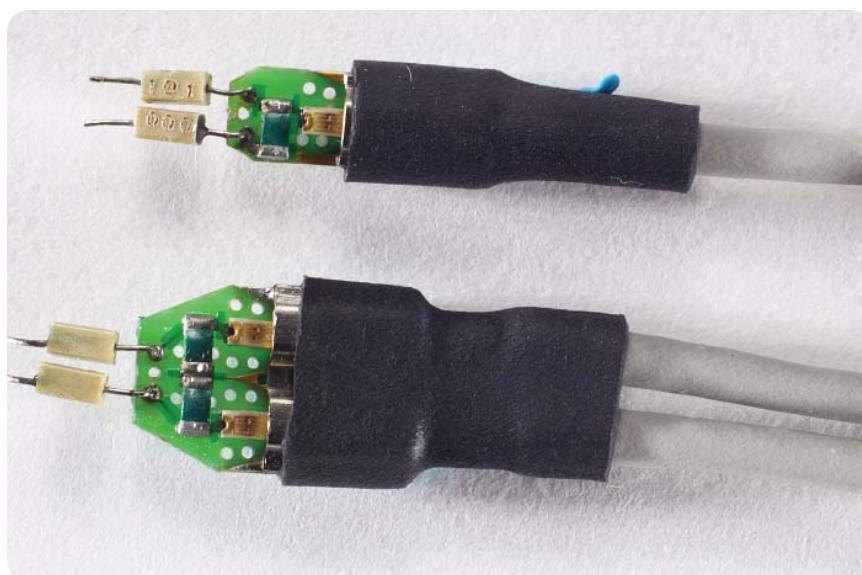

Figure 3. Close up of single-ended (top) and differential (bottom) solder-in probe heads

(l_g s) are significant. The ground inductance allows a voltage to develop between your device’s ground and the probe ground at higher frequencies, thereby reducing the signal at the attenuator/amp input. If you could reduce the ground inductance, you would increase the bandwidth. Reducing the ground inductance requires either shortening the length of

the ground connection or making the connection more massive. The ideal ground connection would be a very short, wide conductor plane or a cylinder around the signal connection (which creates a coaxial probe connection). These ideal ground connections are generally not practical for real-world probing situations and would greatly reduce the usability of a single-ended probe.

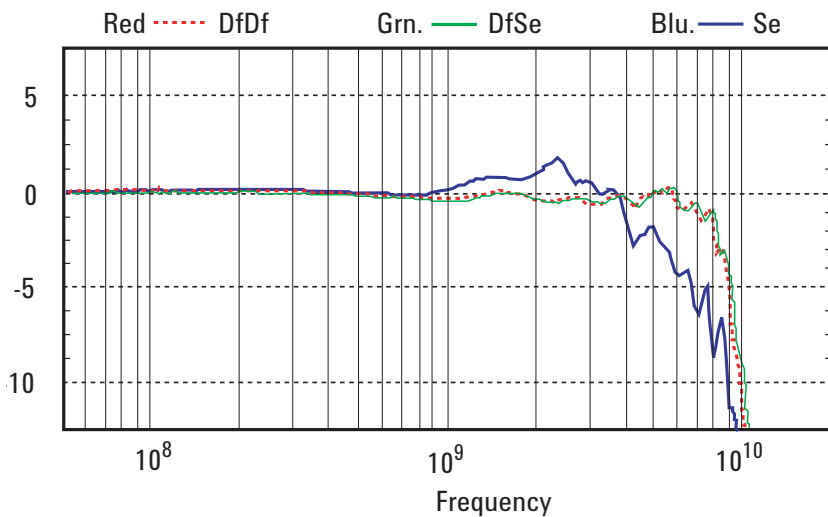

Figure 4. Frequency response of differential and single-ended probes

Additionally, it is not useful to specify a single-ended probe in a coaxial fixture that cannot be used for actual measurements.

If you analyze the differential model driven from a differential signal ($v_{cm}=0$ $v_p=v_m$), you see that due to the inherent symmetry of the plus and minus signal connections, a plane exists between the connections where no net signal is present. You can think of this “effective” ground plane as solidly connected to your device's ground plane and to the probe amp ground. Considering this effective ground plane, a half-circuit model can be analyzed where the loop area of the signal over ground has approximately half the loop area of the single-ended case, and therefore much lower inductance. This analysis of the half-circuit model shows that the bandwidth of the differential model is much higher than the single-ended model. Additionally, the effective ground plane is an ideal ground

connection, but it does not hamper usability at all.

When the differential probe is driven from a single-ended source, you can use superposition to determine the overall response. A single-ended signal is applied in the model when $v_{cm}=v_p=v_m$. For the first term of the superposition, turn v_{cm} “off” and for the second term of the superposition, turn v_p and v_m “off.” The first term is simply the response to the differential component of the single-ended signal, so the response is the same as previously discussed. The second term is the response to the common mode component of the single-ended signal, so the response is determined by the common mode rejection of the probe. If the probe has good common mode rejection, the overall response to a single-ended signal is just the response to the differential component of that single-ended signal. If the probe doesn't have good common

mode rejection, you will see a difference in the response when you measure a differential signal and when you measure a single-ended signal. Figure 4 shows that there is virtually no difference in these responses.

Figure 4 shows the measured frequency response of the differential probe probing a single-ended signal (green), and the single-ended probe probing a single-ended signal (blue), both using the same 7 GHz probe amplifier. The bandwidth of the probe is defined as the frequency where the magnitude of the output of the probe divided by the input of the probe is down 3 db. It is clear that the differential probe head has significantly more bandwidth than the single-ended probe head (7.8 GHz versus 5.4 GHz). Both probes have good frequency flatness due to proper damping resistors used in the connection.

Figure 5 shows the measured time-domain response of the differential probe to an ~100 pS rise time step at its input. Figure 6 shows the measured time domain response of the single-ended probe to an ~100 pS rise time step at its input. In both figures the red trace is the output of the probe and the green trace is the input of the probe. Note, this is not the step response of the probes, but simply a measure of how well they can track a 100 pS step. In order to measure the step response, the input would have to be a perfect, very fast rise time step, and in this case the differential probe would show a faster rise time than the single-ended probe. Both probes track the 100 pS step very well.

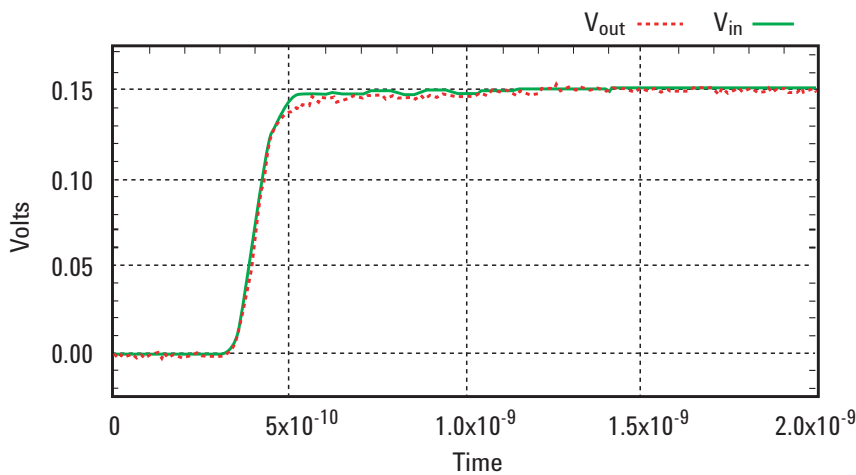

Figure 5. Time response of a differential probe to a 100 pS step

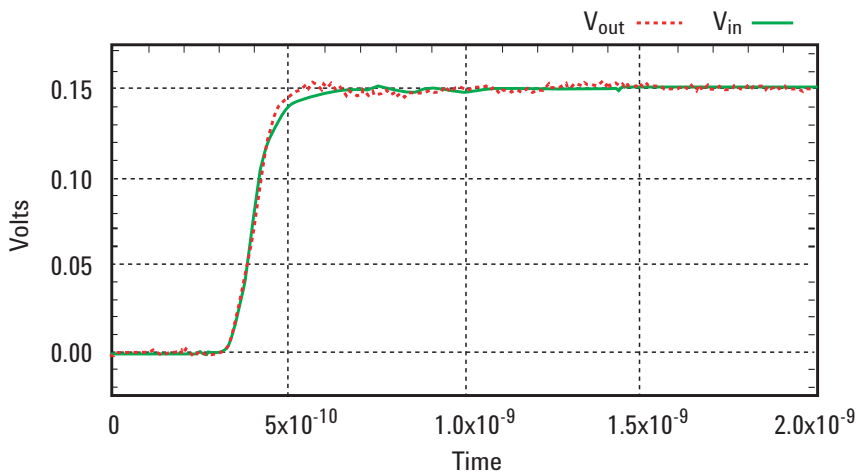

Figure 6. Time response of a single-ended probe to a 100 pS step

Common Mode Rejection Issues

Common mode rejection is an issue for both differential and single-ended probes. For a differential probe, common mode rejection happens when a signal common to both the + and - probe inputs does not produce an output. For a single-ended probe, common mode rejection happens

when a signal common to both the signal and ground inputs does not produce an output.

The models for both the differential and single-ended probes (Figure 1) show a resistor and inductor from the probe attenuator/amp

ground to "earth" ground. This is a simplified model of the impedance caused by the transmission line (or antenna) formed by the shield of the probe cable and earth ground. This "outside mode" impedance is important because when you apply a common mode signal to the single-ended probe, the ground inductance forms a divider with this outside mode impedance and attenuates the ground signal getting to the amplifier. Since the signal input of the amplifier does not have the same attenuation as the ground input, there is a net signal at the amp input and hence an output is produced. The higher the ground inductance is, the lower the common mode rejection

will be, so when you use single-ended probes it is important to keep the ground as short as possible. It is important to note that this outside mode signal does not directly affect the "inside mode" signal (which is the normal probe output signal inside the coaxial cable) but reflected outside mode signal will affect the probe amp ground and therefore indirectly affect the inside mode signal. This is explored further in the "Measurement Repeatability" section.

When a common mode signal is applied to the differential probe, the same signal is seen by both the + and - inputs to the attenuator/amp. The only output produced will be a function of the common mode rejection of the amplifier, which is not due to connection inductance.

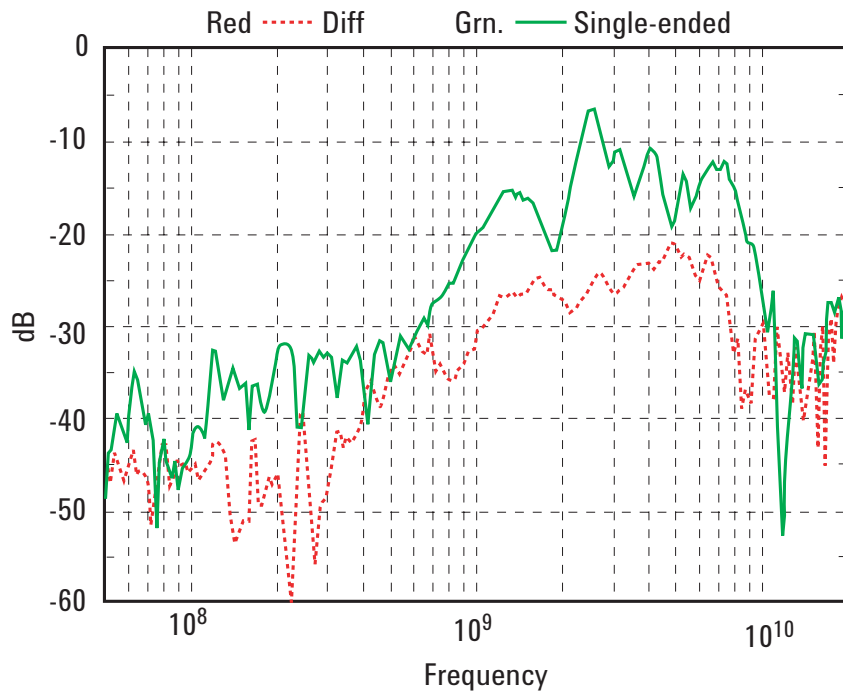

Figure 7. Common mode response of differential and single-ended probes

You need to determine if the single-ended probe or the differential probe has better common mode rejection when you probe a single-ended signal with common mode noise. This depends on the ground connection inductance of the single-ended probe, and the common mode rejection of the amp in the differential probe. For the differential and single-ended probe heads in this example, Figure 7 shows that the differential probe has considerably more common mode rejection than the single-ended probe and therefore would make a better measurement in a high-common-mode-noise environment. This is typically the case for differential versus single-ended probes, unless the single-ended probe has an extremely low

inductance ground connection, which is difficult to achieve in practice. It is important to note that the common mode rejection of the single-ended probe analyzed here is as good or better than many single-ended probes because its ground lead is very short. The common mode responses graphed in Figure 7 are defined as:

Differential CM response = $20[\log(\text{voc}/\text{vic})]$
 where vic is the common voltage on both the + and - inputs
 voc is the voltage at the probe output when vic is applied

Single-ended CM response = $20[\log(\text{voc}/\text{vic})]$
 where vic is the common voltage on the signal and ground inputs
 voc is the voltage at the probe output when vic is applied

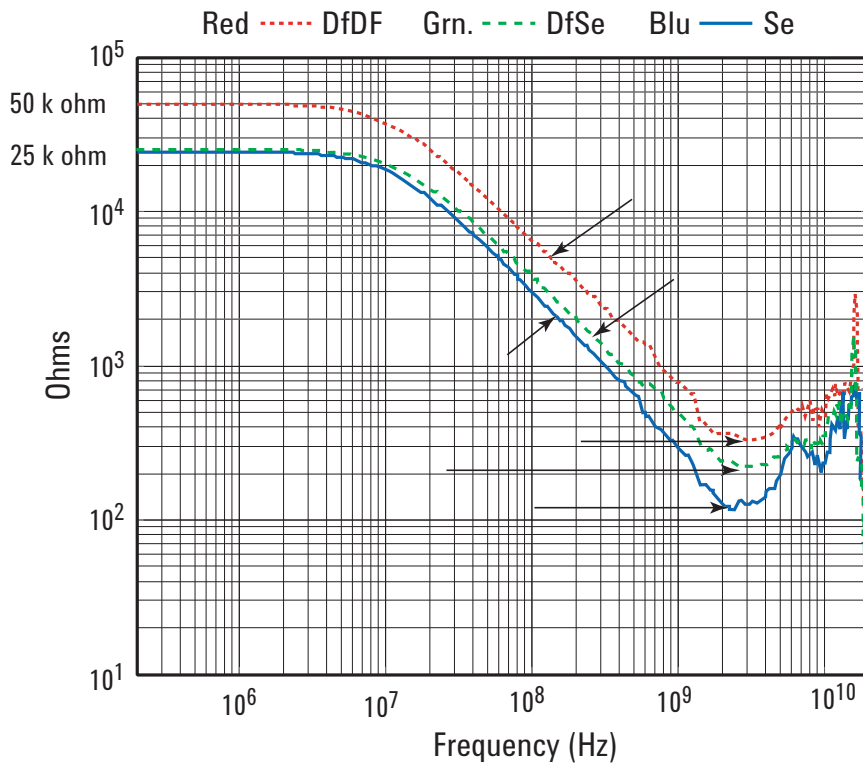

Figure 8. Input impedance of differential and single-ended probes

Input Loading Comparison

If you analyze the models in Figure 1 with values of inductors and capacitors derived from the differential and single-ended probe heads, you will see that the input impedances seen by a single-ended source looking into each probe head is not substantially different. A minor point in this analysis is how the outside mode impedance affects the differential and single-ended probes. In the single-ended probe amp model, the outside mode impedance is generally much greater than the ground

connection impedance (due to lgs), so it does not affect the input impedance noticeably. However, due to the outside mode impedance, a single-ended signal into the differential probe will see a slightly lower capacitance value at higher frequencies than at lower frequencies.

Figure 8 is a plot of the input impedance (magnitude) of the differential and single-ended probe. The red trace is the impedance seen by a differential source into the differential probe.

The green trace is the impedance seen by a single-ended source into the differential probe and the blue trace is the impedance seen by a single-ended source into the single-ended probe. Values for DC resistance, capacitance, and minimum impedance for these three cases are annotated in Figure 8. Note that the input impedance to a single-ended signal is similar for the differential and single-ended probe.

Measurement Repeatability

Repeatability of measurements is an issue with high-frequency probes. Ideally, probe position, cable position, and hand position should not cause variation in probe measurements.

Unfortunately, many times they do cause variation. Variation in the outside mode impedance is the usual cause. This impedance is really more complex than shown in the probe models because it is an unshielded transmission line (or antenna) that probe, hand, and cable positions can affect greatly.

If you analyze the single-ended model with variation in the outside mode impedance, you will see that this variation causes the response to change. Additionally, since the outside mode impedance is also a factor in the common mode response, variation in this impedance causes the common mode rejection to vary. The higher the inductance of the ground connection, the bigger the response variations will be.

Analysis of the differential model with variation in the outside mode impedance shows that this variation causes very little change in the response. Any signal that is present on the probe amp ground is rejected by the common mode rejection of the amplifier. Therefore, response variations due to probe, hand, or cable positions are greatly attenuated.

In Figure 4, page 4, the differential probe has a smoother response than the single-ended probe. Many of the "bumps and wiggles" on the response of single-ended probes are due to variations in the outside mode impedance. When this impedance varies, the response varies.

Ferrite beads on the probe cable can help this problem somewhat by attenuating and terminating the outside mode signal and therefore reducing the variability of the outside mode impedance. This decreases the variability of the response due to probe, hand, and cable positions.

Physical Size Considerations

The preceding comparisons of differential and single-ended probes indicate that the differential probe has better performance in every category for probing either differential or single-ended signals. However, there are still situations where it makes sense to use a single-ended probe. Single-ended probes can make acceptable measurements in many situations, and they may cost less and be physically smaller due to less complexity in the tip networks. A physically small probe can allow you to probe in confined areas and to connect multiple probes to probe points that are very close together. From this viewpoint, it would be best to have a probe that allows either differential or single-ended probing in a single probing system.

Summary

Because of ground bounce, cross-talk, and EMI problems, the electronics industry is moving to differential instead of single-ended signaling. For measurement equipment to be useful in this new realm, differential probing is an absolute necessity. Since the effective ground plane between the signal connections in differential probes is more ideal than most of the usable (non-coaxial) ground connections in single-ended probes, differential probes can make better measurements on single-ended signals than single-ended probes can. New generation differential probes are easy to use, have state-of-the-art performance, and are cost effective, when you use them for probing both differential and single-ended signals.

Glossary

Bandwidth – the frequency at which the magnitude of the frequency response is equal to -3 db (or 0.707).

Common mode component – components of two signals that are equal.

Common mode rejection – for circuits that perform the function $input1 - input2$, common mode components of $input1$ and $input2$ do not produce an output.

Differential mode component – components of two signals that are equal and opposite.

Differential signal – a method of electronic signaling using two conductors where the signal on one conductor is equal and opposite to the signal on the other conductor.

Frequency response – $v_o(s)/v_i(s)$, where $v_o(s)$ is the output signal as a function of frequency and $v_i(s)$ is the input signal as a function of frequency.

Half-circuit analysis – method of analyzing a symmetrical circuit where all currents and voltages on one side of a line of symmetry are equal and opposite to the other side; the nodes on the line of symmetry can be tied together and considered to be a common or ground node in the analysis.

Outside mode – signal that travels on the outside conductor of a coaxial line.

Outside mode impedance – the impedance from the outside conductor of a coaxial line to earth or local ground (for example, an antenna).

Single-ended signal – a method of electronic signaling using one signal conductor and a common ground conductor. Nominally, the common ground conductor has no signal on it and the signal conductor moves relative to the ground conductor.

Step response – the response of a network when stimulated by an ideal step. An ideal step has zero rise time.

Superposition – in a linear system, the output of a system stimulated by multiple independent sources can be determined by summing the output of the system to each source independently.

Related Literature

Publication Title	Publication Type	Publication Number
<i>Eight Hints for Better Scope Probing</i>	Application note	5989-7894EN
<i>Agilent Infiniium DSO/DSA 90000A Series</i>	Data sheet	5989-7819EN
<i>Extending the Range of Agilent InfiniiMax Probes</i>	Application note	5989-7587EN
<i>Agilent Oscilloscope Probes and Accessories</i>	Selection guide	5989-6162EN
<i>Restoring Confidence in Your High-Bandwidth Probe Measurements</i>	Application Note 1419-01	5988-7951EN
<i>Improving Usability and Performance in High-Bandwidth Active Oscilloscope Probes</i>	Application Note 1419-02	5988-8005EN
<i>Performance Comparison of Differential and Single-Ended Active Voltage Probes</i>	Application Note 1419-03	5988-8006EN
<i>The Truth About the Fidelity of High-Bandwidth Voltage Probes</i>	Application Note 1404	5988-6515EN



Agilent Technologies Oscilloscopes

Multiple form factors from 20 MHz to >90 GHz | Industry leading specs | Powerful applications



Agilent Email Updates

www.agilent.com/find/emailupdates

Get the latest information on the products and applications you select.



Agilent Direct

www.agilent.com/find/agilentdirect

Quickly choose and use your test equipment solutions with confidence.



www.agilent.com/find/open

Agilent Open simplifies the process of connecting and programming test systems to help engineers design, validate and manufacture electronic products. Agilent offers open connectivity for a broad range of system-ready instruments, open industry software, PC-standard I/O and global support, which are combined to more easily integrate test system development.



www.lxistandard.org

LXI is the LAN-based successor to GPIB, providing faster, more efficient connectivity. Agilent is a founding member of the LXI consortium.

Agilent T&M Software and Connectivity

Agilent's Test and Measurement software and connectivity products, solutions and developer network allows you to take time out of connecting your instruments to your computer with tools based on PC standards, so you can focus on your tasks, not on your connections. Visit www.agilent.com/find/connectivity for more information.

Windows® is a U.S. registered trademark of Microsoft Corporation.

Remove all doubt

Our repair and calibration services will get your equipment back to you, performing like new, when promised. You will get full value out of your Agilent equipment throughout its lifetime. Your equipment will be serviced by Agilent-trained technicians using the latest factory calibration procedures, automated repair diagnostics and genuine parts. You will always have the utmost confidence in your measurements.

Agilent offers a wide range of additional expert test and measurement services for your equipment, including initial start-up assistance onsite education and training, as well as design, system integration, and project management.

For more information on repair and calibration services, go to

www.agilent.com/find/removealldoubt

www.agilent.com

For more information on Agilent Technologies' products, applications or services, please contact your local Agilent office. The complete list is available at:

www.agilent.com/find/contactus

Phone

Americas

Canada	(877) 894-4414
Latin America	305 269 7500
United States	(800) 829-4444

Asia Pacific

Australia	1 800 629 485
China	800 810 0189
Hong Kong	800 938 693
India	1 800 112 929
Japan	81 426 56 7832
Korea	080 769 0800
Malaysia	1 800 888 848
Singapore	1 800 375 8100
Taiwan	0800 047 866
Thailand	1 800 226 008

Europe

Austria	0820 87 44 11
Belgium	32 (0) 2 404 93 40
Denmark	45 70 13 15 15
Finland	358 (0) 10 855 2100
France	0825 010 700
Germany	01805 24 6333* *0.14€/minute
Ireland	1890 924 204
Italy	39 02 92 60 8484
Netherlands	31 (0) 20 547 2111
Spain	34 (91) 631 3300
Sweden	0200-88 22 55
Switzerland	(French) 44 (21) 8113811 (Opt 2)
Switzerland	(German) 0800 80 53 53 (Opt 1)
United Kingdom	44 (0) 7004 666666

Other European countries:
www.agilent.com/find/contactus

Revised: March 23, 2007

Product specifications and descriptions in this document subject to change without notice.

© Agilent Technologies, Inc. 2001, 2008
Printed in USA, June 20, 2008
5988-8006EN



Agilent Technologies