

Agilent PNA Microwave Network Analyzers

Application Note 1408-15

Banded Millimeter-Wave Measurements with the PNA

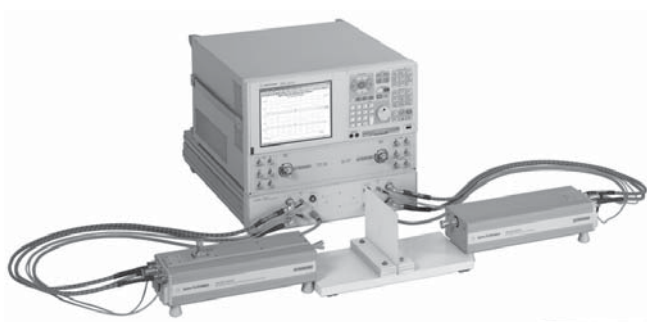
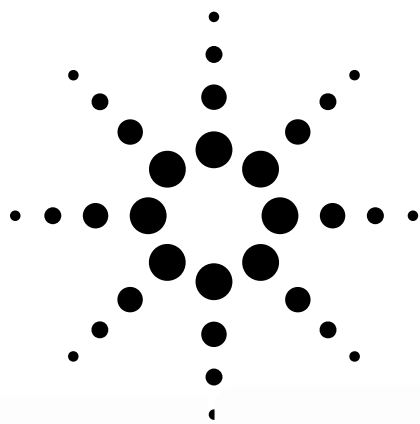

Agilent Technologies

Table of Contents

| | |
|---|----|
| Introduction | 3 |
| System Configuration | 4 |
| System Operation | 8 |
| Configuring millimeter-wave modules | 9 |
| Configuring external synthesizers | 11 |
| Operational notes..... | 14 |
| Power control..... | 14 |
| Power leveling | 15 |
| Expected output power | 15 |
| IF BW selection..... | 15 |
| Resolution of frequency source..... | 15 |
| Multiple channels..... | 15 |
| System Calibration | 16 |
| Choosing the right calibration technique | 16 |
| Loading and checking calibration definition file..... | 17 |
| Configuration #1: Two T/R modules | 20 |
| Configuration #2: One T/R & one T modules | 21 |
| Application Examples | 24 |
| Example #1: Antenna measurements | 24 |
| Example #2: Pulsed measurements..... | 25 |
| Example #3: Materials measurements..... | 27 |
| Appendix A: Creating Your Own Waveguide Calibration Kit Definition | 28 |
| Appendix B: Performing Calibrations | 34 |
| SmartCal, 2-port | 34 |
| SmartCal, 1-port | 37 |
| Unguided Calibration, Thru Response..... | 39 |
| Appendix C: Caring for Waveguide Interfaces | 41 |
| Appendix D: Supplemental Data | 42 |

Introduction

Millimeter-wave is becoming more common as measurement needs are pushed beyond 110 GHz, to 220 GHz, 325 GHz, and even 1 THz! Applications include on-wafer device characterizations as well as various types of materials measurements.

The PNA series network analyzers can be configured for wide dynamic range reflection and transmission measurements of components at millimeter-wave frequencies. Two types of millimeter-wave solutions are available from Agilent Technologies:

1. One solution is the N5250C network analyzer. With 1.0mm coaxial test port connectors, this solution provides single, continuous measurement sweeps from 10 MHz to 110 GHz.
2. The other solution is based on banded millimeter-wave test head modules with waveguide (WG) interfaces. System configuration differs depending on frequency range of interest.

The objective of this application note is to provide detailed information on the banded millimeter-wave solutions. This includes system configurations, system operation, system calibration, and some typical measurement examples. This note applies to the following product numbers within the PNA and PNA-X series: E8362B, E8363B, E8364B, E8361A, N5242A, N5244A and N5245A.

Banded Millimeter Wave System Configuration

To configure a banded millimeter wave measurement system, three basic components are required:

1. A performance network analyzer
2. Millimeter wave test set controller
3. A waveguide module based on application need and frequency band
4. An optional calibration kit in waveguide unless on-wafer or other media is being used

Performance network analyzer

| Product model | Description | Minimum required options |
|-----------------------|--|----------------------------|
| E8362C | 20 GHz 2-port performance network analyzer | H11, 080, 081, 014 and UNL |
| E8363C | 40 GHz 2-port performance network analyzer | H11, 080, 081, 014 and UNL |
| E8364C | 50 GHz 2-port performance network analyzer | H11, 080, 081, 014 and UNL |
| E8361C | 67 GHz 2-port performance network analyzer | H11, 080, 081, 014 and UNL |
| N5242/44/45A Opt. 2xx | 2-port PNA-X network analyzer | Option 020 |
| N5242/44/45A Opt. 4xx | 4-port PNA-X network analyzer | Option 020 |

Note: When configuring the N5242/44/45A (Option 200 and 224 required) with a N5262A 4-port millimeter wave test set controller, also include Option 551 for 4-port calibration capability.

Optionally for rear panel connection of the RF source to the N5261A/N5262A test set controller include the switch combiner options to the N5242/44/45A selected above. For N5242/44/45A with Option 2xx, add Option 224 and for the N5242/44/45A with Option 4xx, add Option 423.

For E836x based systems used with modules above 200 GHz, these systems require a pair of external synthesizers (one for RF and the other for LO) to increase the dynamic range, see Figure 9 for improvement. Recommended synthesizers are E8257D with Options 520 and UNX.

Millimeter wave test set controllers

| Product number | Description | Options |
|----------------|--|---|
| N5260A | 2-port test controller for PNA based solution | Includes all cables for connection to PNA as well as two sets of 48 inch RF, LO, DC and IF cables for connection to a pair of T/R millimeter modules. |
| N5261A | 2-port test set controller for PNA-X based configuration | <ul style="list-style-type: none"> • Option 102 – A set of cables for connection to a 2-port PNA-X • Option 104 – A set of cables for connection to a 4-port PNA-X • Option 50x – A single set of RF, LO, DC and IF cables for connection to a single T/R millimeter module (see Option Descriptions for details). |
| N5262A | 4-port test set controller for PNA-X based configuration | <ul style="list-style-type: none"> • Option 102 – A set of cables for connection to a 2-port PNA-X • Option 104 – A set of cables for connection to a 4-port PNA-X • Option 50x – A single set of RF, LO, DC and IF cables for connection to a single T/R millimeter module (see Option Descriptions for details). |

When configuring the PNA-X with a N5260A millimeter wave test set controller, please include a 10 dB 3.5 mm pad for connection to the LO and a set of four BNC to SMA adapters.

Millimeter wave modules

Several modules are available and other special options may be configured on request. Select the appropriate quantity of modules required for the measurement set up. To request a specially configured test module contact your local Agilent sales engineer.

The single and dual channel receiver modules are used for antenna applications or for 1-port single path S-parameter measurements.

Transmission reflection modules

| Waveguide flange | Frequency GHz | Standard transmission/reflection modules | Transmission/reflection Modules with 25 dB mechanical attenuator | Transmission/reflection Modules with 15 dB LO and RF amplifier ¹ |
|------------------|---------------|--|--|---|
| WR22 | 33 - 50 | N5256AW22 - STD | N5256AW22 - 001 | N5256AW22 - 002 |
| WR15 | 50 - 75 | N5256AW15 - STD | N5256AW15 - 001 | N5256AW15 - 002 |
| WR12 | 60 - 90 | N5256AW12 - STD | N5256AW12 - 001 | N5256AW12 - 002 |
| WR10 | 75 - 110 | N5256AW10 - STD | N5256AW10 - 001 | N5256AW10 - 002 |
| WR08 | 90 - 140 | N5256AW08 - STD | N5256AW08 - 001 | N5256AW08 - 002 |
| WR06 | 110 - 170 | N5256AW06 - STD | N5256AW06 - 001 | N5256AW06 - 002 |
| WR05 | 140 - 220 | N5256AW05 - STD | N5256AW05 - 001 | N5256AW05 - 002 |
| WR03 | 220 - 325 | N5256AW03 - STD | N5256AW03 - 001 | N5256AW03 - 002 |
| WR02.2 | 325 - 500 | N5256AW02 - STD | Not available | N5256AW02 - 002 ² |
| Extended WR12 | 56 - 94 | N5256AX12 - STD | N5256AX12 - 001 | Available on request |

- Note the modules with the RF/LO amplifiers are for antenna applications that include a cable loss of 15 dBm to the module from the port of the Test set being used. Do not connect these directly to the test set controller port with the standard 48 inch cable, use a 15 dB pad if needed.
- These modules require an external DC power supply (e.g. E3615A) when using them with the N5260A.
- For transmission reflection modules with both the 25 dB mechanical attenuator and the 15 dB LO and RF amplifier order N5256AWxx-003. Not available for N5256AW02

Single channel receive modules

| Waveguide flange | Frequency GHz | Standard single channel receive modules | Single channel receive modules with 15 dB LO amplifier |
|------------------|---------------|---|--|
| WR22 | 33 - 50 | N5257AR22 - STD | N5257AR22 - 001 |
| WR15 | 50 - 75 | N5257AR15 - STD | N5257AR15 - 001 |
| WR12 | 60 - 90 | N5257AR12 - STD | N5257AR12 - 001 |
| WR10 | 75 - 110 | N5257AR10 - STD | N5257AR10 - 001 |
| WR08 | 90 - 140 | N5257AR08 - STD | N5257AR08 - 001 |
| WR06 | 110 - 170 | N5257AR06 - STD | N5257AR06 - 001 |
| WR05 | 140 - 220 | N5257AR05 - STD | N5257AR05 - 001 |
| WR03 | 220 - 325 | N5257AR03 - STD | N5257AR03 - 001 |
| WR02.2 | 325 - 500 | N5257AR02 - STD | Available on request |

Dual channel receive modules

| Waveguide flange | Frequency GHz | Standard dual channel receive module | Dual channel receive module with 15 dB LO amplifier |
|------------------|---------------|--------------------------------------|---|
| WR15 | 50 - 75 | N5258AD15 - STD | N5258AD15 - 001 |
| WR12 | 60 - 90 | N5258AD12 - STD | N5258AD12 - 001 |
| WR10 | 75 - 110 | N5258AD10 - STD | N5258AD10 - 001 |
| WR08 | 90 - 140 | N5258AD08 - STD | N5258AD08 - 001 |
| WR06 | 110 - 170 | N5258AD06 - STD | N5258AD06 - 001 |
| WR05 | 140 - 220 | N5258AD05 - STD | N5258AD05 - 001 |
| WR03 | 220 - 325 | N5258AD03 - STD | N5258AD03 - 001 |

Millimeter wave calibration kits

| Waveguide flange | Frequency GHz | Calibration kit |
|------------------|---------------|-----------------|
| WR22 | 33 - 50 | Q11644A |
| WR15 | 50 - 75 | V11644A |
| WR12 | 60 - 90 | N5260AC12 |
| WR10 | 75 - 110 | W11644A |
| WR08 | 90 - 140 | N5260AC08 |
| WR06 | 110 - 170 | N5260AC06 |
| WR05 | 140 - 220 | N5260AC05 |
| WR03 | 220 - 325 | N5260AC03 |
| WR02.2 | 325 - 500 | N5260AC02 |
| Extended WR12 | 56 - 94 | N5260AC12 |

OML VNA2 waveguide test head modules are available in transmission/reflection (T/R) and transmission (T) configurations. Each Agilent part number, N5260AWxx, includes a pair of T/R test head modules and the respective WG calibration kit. Figures 2 and 3 show the simplified block diagrams of an OML VNA2 T/R test head module and a T test head module, respectively. Other combinations of test head modules may be available from Agilent Technologies; as an example, one T/R and one T modules. Please contact your local Agilent Technologies representative for more detail.

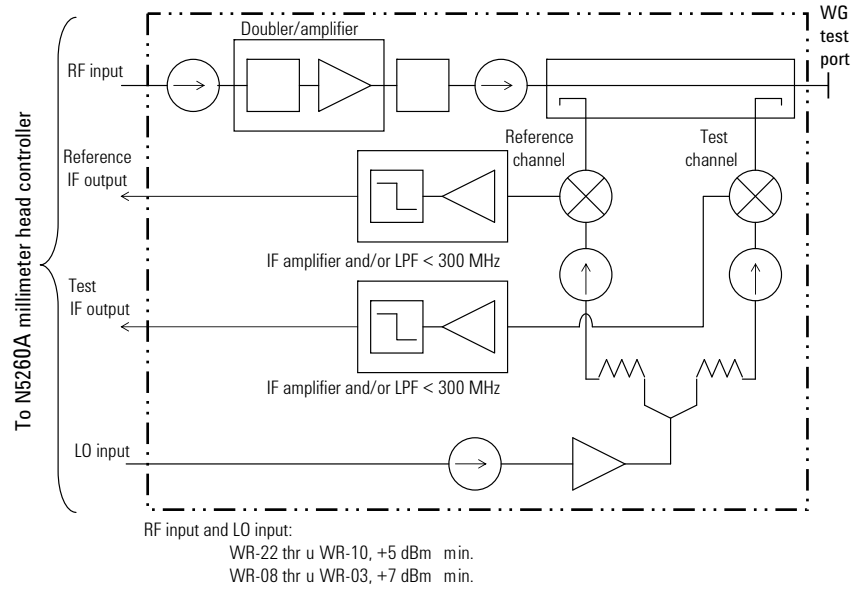

Figure 2. Simplified block diagram of an OML T/R test head module.

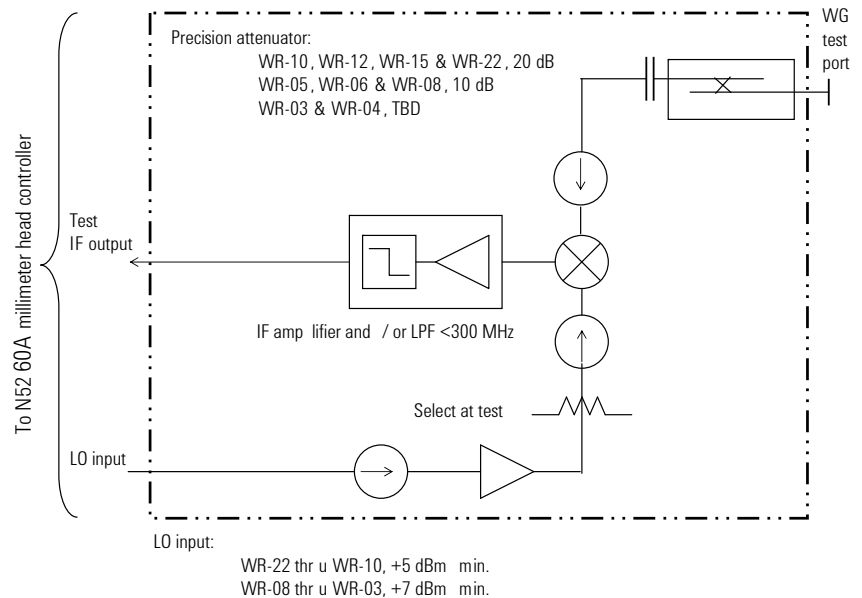

Figure 3. Simplified block diagram of an OML T test head module.

Different combination of test head modules covering the same frequency range can be used together, but will result in different available parameters. Table 3 shows details of the possible combinations. A full “S-parameter” test set requires two T/R modules. One T/R module and one T module will result in a “T/R” test set where only one transmission measurement and one reflection measurement are possible.

Table 3. Combination of test head modules and available measurements.

| | Port 1 | Port 2 | Available Parameters | Comments |
|-------------------------------|------------|------------|----------------------|---|
| Combination #1 (Figure 4a) | T/R module | T/R module | S11, S21, S12, S22 | Both ports 1 and 2 can supply stimulus to DUT |
| Combination #2 (Figure 4b) | T/R module | T module | S11, S21 | Only port 1 can supply stimulus to DUT |

If S12 and S22 are needed for combination #2, two approaches are possible:

1. Reverse the DUT to measure the reverse parameters.
2. Reconfigure the test head modules by placing the T/R module on port 2 and the T module on port 1. This approach requires a calibration before measurements can be made.



(a)



(b)

Figure 4. Two combinations of test head modules: (a) Two T/R modules, and (b) one T/R module (left) and one T module.

System Operation

This section describes how to operate the banded millimeter-wave system. System operation includes creating a configuration for each set of millimeter-wave modules, calibrating the system, and taking measurements.

Figures 5 and 6 illustrate the front and rear panel connections of the system. Rear panel connections are slightly different if external synthesizers are used (Figure 6b). For details on system installation, please refer to the N5250A Network Analyzer Systems Installation Guide, part number N5250-90001.

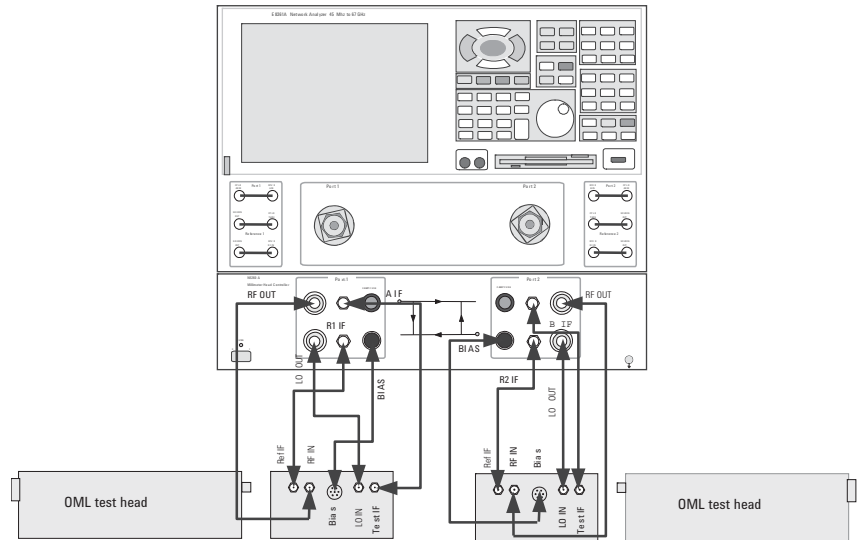

Figure 5. Front panel connections of the N5260A millimeter-wave controller to the waveguide test head modules.

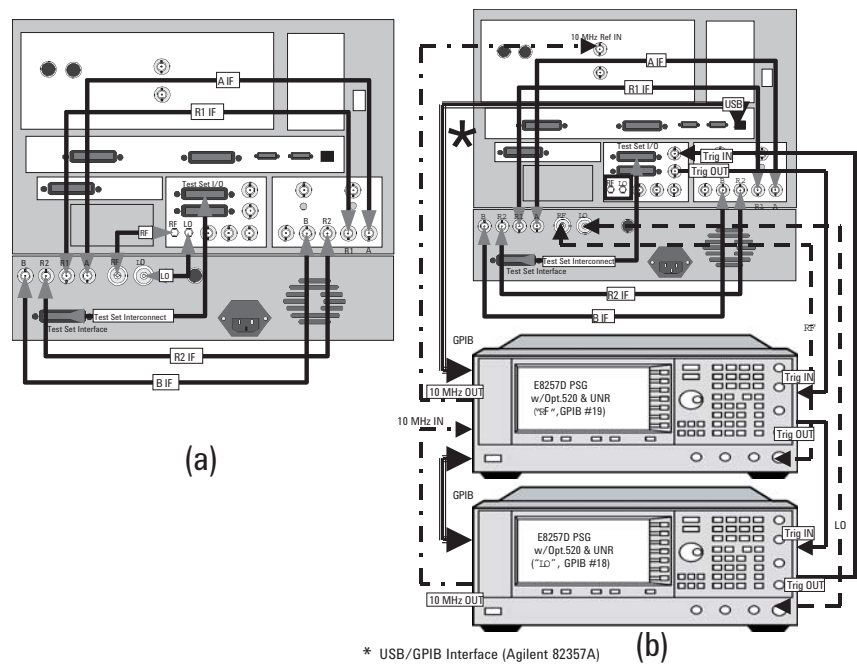

Figure 6. Rear panel connections: (a) without external synthesizers, and (b) with two PSGs as external synthesizers. Connection between the PNA and a PSG must be done via USB/GPIB Interface (Agilent 82357A), and PNA Trig OUT must go to Trig IN of RF synthesizer.

System setup procedure has been greatly simplified due to extensive enhancements made to the PNA firmware. The following steps show how to create a configuration for each set of millimeter-wave modules. For multiple frequency bands, one configuration is needed for each band.

Configuring millimeter-wave modules:

Before proceeding to the front panel of the PNA, please make sure the rear panel connection of the system is completed as illustrated in Figure 6a, and the N5260A millimeter-wave controller has been turned on.

1. **System > Configure > Millimeter Module Config...**, this brings up display (a) as shown in Figure 7.
2. Click on **Module Config**, this brings up display (b).
3. Click on **New**, this brings up display (c), and enter the name of configuration. It is best for the name to be descriptive and representative of the frequency band. (The example shows "60 to 90 GHz".)
4. Click **OK**. This brings up display (d). Enter values of the frequency range and the values of the multipliers, both RF and LO. Multiplier values can be obtained either from the labels on the test head modules, or from Table 4 below. Click **Save** when done.

Table 4. RF and LO harmonic multipliers of each frequency range.

| Band | Frequency range of operation (GHz) | RF frequency range (GHz) | RF harmonic multiplier | LO frequency range \pm IF offset (GHz) | LO harmonic multiplier |
|-------------|---|---------------------------------|-------------------------------|--|-------------------------------|
| WR-15 | 50 – 75 | 12.5 to 18.8 | N = 4 | 10.0 to 15.0 | M = 5 |
| WR-12 | 60 – 90 | 10.0 to 15.0 | N = 6 | 12.0 to 18.0 | M = 5 |
| WR-10 | 75 – 110 | 12.5 to 18.4 | N = 6 | 9.3 to 13.8 | M = 8 |
| WR-08 | 90 – 140 | 7.5 to 11.7 | N = 12 | 11.2 to 17.5 | M = 8 |
| WR-06 | 110 – 170 | 9.1 to 14.2 | N = 12 | 11.0 to 17.0 | M = 10 |
| WR-05 | 140 – 220 | 11.6 to 18.4 | N = 12 | 14.7 to 18.1 | M = 12 |
| WR-04 | 170 – 260 | 8.5 to 13.0 | N = 20 | 12.1 to 18.6 | M = 14 |
| WR-03 | 220 – 325 | 12.2 to 18.1 | N = 18 | 12.2 to 18.1 | M = 18 |

5. To apply a configuration, highlight the configuration, and then click on **Activate Selected Config**. This brings up display (e), click **OK** and the PNA will exit and restart with the new configuration, as shown in Figure 8. This step may take a minute.

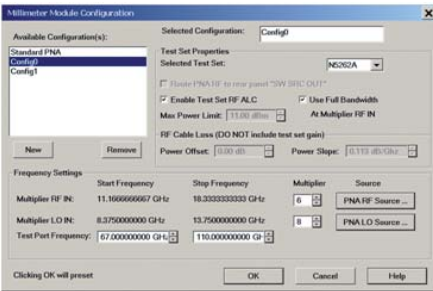

Step One: Select **System Configure Millimeter Wave** configuration to initiate setup.

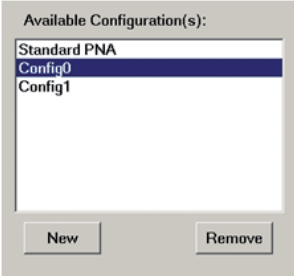

Step Two: Provide a **Name** for the Configuration



Step Three: Test Set Configuration
 Select **Test Set Controller** being used.
 Uncheck **RF ALC** only if you need to make **Pulse** measurements.
 Check "**Use Full Bandwidth**" only for mixer measurements.
 Leave all other settings to default.

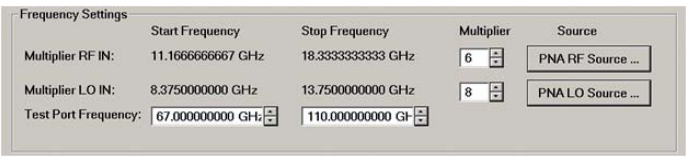

Step Four: Frequency Settings
 Set the **RF** multiplier factor for the frequency extenders.
 Set the **LO** multiplier factor for the frequency extenders.
 Set the **Start** and **Stop Frequency** for the frequency extender.
 Select **PNA RF** or **PNA LO** source if external sources are being used.

Figure 7. Steps necessary to create a millimeter-wave module configuration. The example shows a frequency band of 67 to 110 GHz.

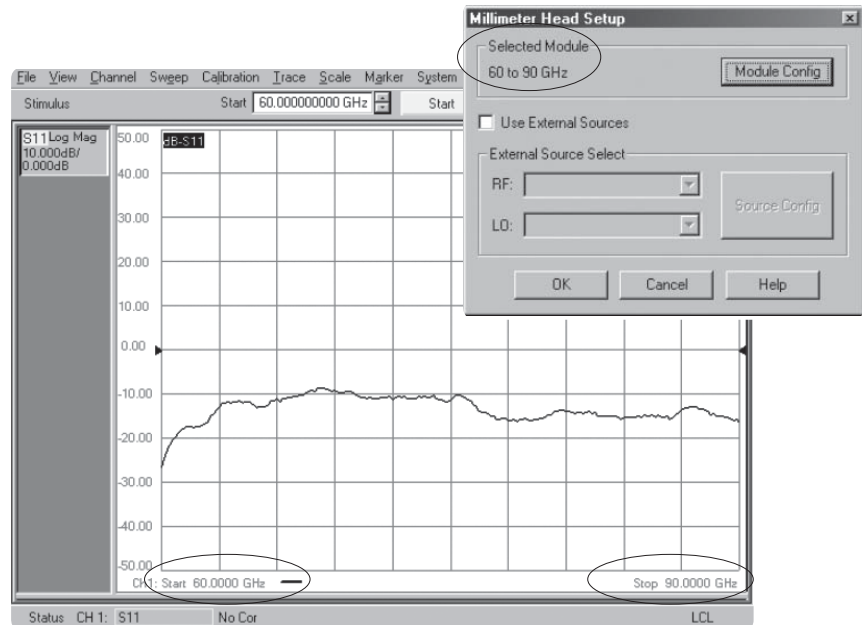

Figure 8. PNA operating in newly created millimeter-wave band configuration.

Configuring external synthesizers:

External synthesizers can be added to any banded millimeter-wave configuration at anytime. Before proceeding to the PNA front panel,

- make sure the rear panel connection of the system is completed as illustrated in Figure 6b
- turn on the N5260A millimeter-wave controller
- turn on both external synthesizers and set the GPIB address of each unit via its front panel as illustrated in Figure 6b:

Utility > GPIB/RS-232 LAN > GPIB address

Enter **19** (for the RF unit) and **18** (for the LO unit)

Press softkey **Enter**

Proceed to the PNA front panel to configure the external synthesizers.

1. **System > Configure > External Source Config...**, this brings up display (a) as shown in Figure 9.
2. Click on **Add**, this brings up display (b). Enter "Source Name" and then use the drop-down menu to select the "Source Type" of "AGPSG" (only Agilent PSG Series are supported, please see **Operational Notes** for details). Click **OK**. (The example shows the "Source Name" as "PSG RF 19" to indicate that the synthesizer to be used is the PSG series, the unit is intended for the RF signal, and the GPIB address is 19.)
3. This brings up display (c). With the source name "PSG RF 19" highlighted, click on **Hardware List (BNC)** and then update the "GPIB Address" to make sure it is in agreement with the setup (the address is 19).
4. Click on **Add** (this time to add the LO source). This brings up display (d). Enter "Source Name" and then use the drop-down menu to select the "Source Type" of "AGPSG." Click **OK**. (The example shows the "Source Name" as "PSG LO 18" to indicate that the synthesizer to be used is the PSG series, the unit is intended for the LO signal, and the GPIB address is 18.)
5. This brings up display (e). With the source name "PSG LO 18" highlighted. Click on **Hardware List (BNC)** and then update the "GPIB Address" to make sure it is in agreement with the setup (this time, the address is 18). Click **OK**. You have now completed configuring the external synthesizers.

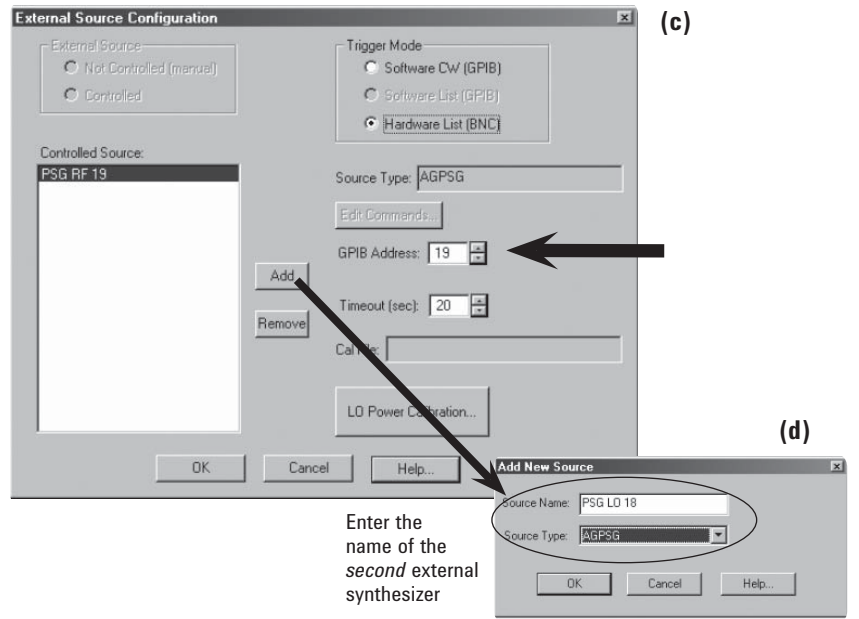
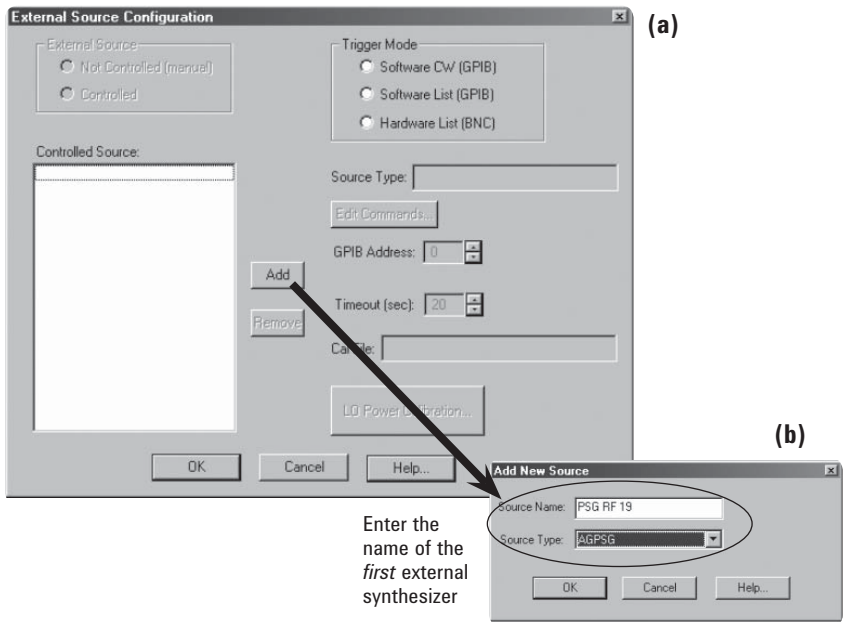

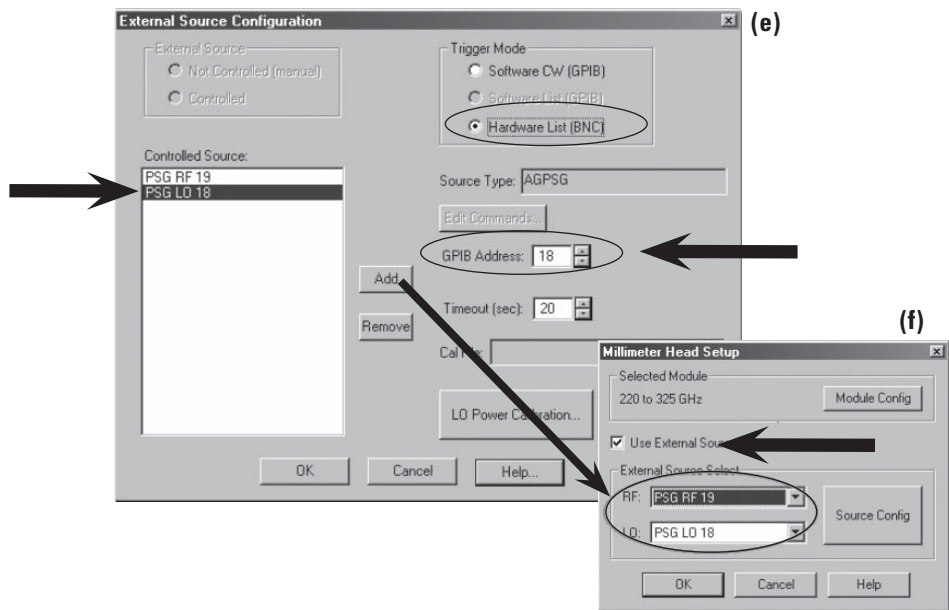

Figure 9. Steps necessary to configure and apply external synthesizers.

Now apply the external synthesizers to the active configuration:

6. **System > Configure > Millimeter Module Config...**, this brings up display (f) of Figure 9. (This example shows the "Selected Module" as "220 to 325 GHz".)
7. Click on **Use External Sources**, and then use the drop-down menu to select the "RF" and "LO" under "External Source Select." Click **OK** when done. (As you can see, all sources you have configured will appear under each drop-down menu. This is why it is important to make the "Source Name" descriptive. Otherwise, it maybe difficult to figure out each one.)

Operational Notes

Power control

Power control is not available when operating at banded millimeter-wave frequencies. Although one appears to be able to vary power under **Channel > Power... > Test Port Power**, in reality, it makes no difference at the waveguide interface because (1) the amplifiers inside the test head modules are designed to operate at saturation (see Figure 2), therefore, increasing the RF Test Port Power in the PNA results in no change at the waveguide interface; (2) the RF and LO outputs from the rear panel of the PNA are coupled off before the splitter or any control mechanism, thus, providing no control for power.

Without external synthesizers, the RF and LO signals are provided by the PNA's rear panel (Option H11). These values vary over a wide range; the typical values are shown in Table 5.

Table 5. Typical values of the RF and LO outputs from the rear panel of the PNA.

| Rear Panel LO power (typical) | |
|---|---|
| 1.7 GHz to 20 GHz | -16 to -7 dBm |
| Rear panel RF power for E8362B (typical) | |
| 1.7 GHz to 20 GHz | -16 to -5 dBm (at -5 dBm test port power ¹) |
| Rear panel RF power for E8363B/E8364B (typical) | |
| 1.7 GHz to 10 GHz | -12 to -2 dBm (at -5 dBm test port power ¹) |
| 10 GHz to 16 GHz | -8 to 0 dBm (at -5 dBm test port power ¹) |
| 16 GHz to 20 GHz | -1 to +5 dBm (at -5 dBm test port power ¹) |

With external synthesizers, the PSG sources are remotely controlled by the PNA. The PNA downloads the frequency list to each PSG (E8257D with Option 520) and the output is set to 0 dBm for each frequency point.

How do we know if the heads are driven with sufficient power?

The ALC loops inside the N5260A millimeter-wave controller are in place to guarantee sufficient RF power is available at the test heads to drive them (see Figure 10).

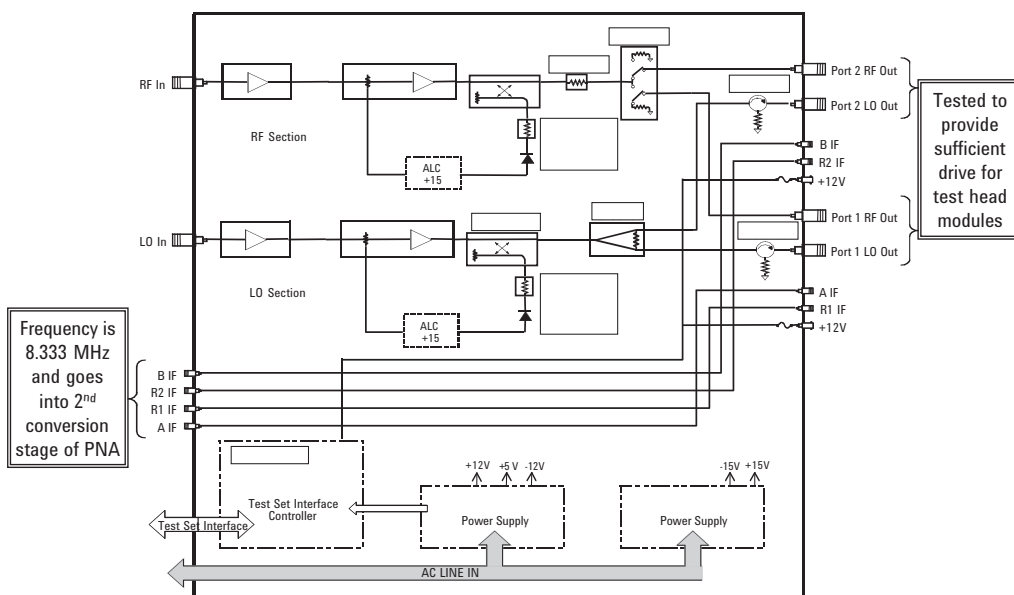

Figure 10. Simplified block diagram of N5260A millimeter-wave controller.

1. Test port power has to be at a high enough level such that the "Drop Cal" does not occur. If Drop Cal occurs, then the power out of the rear panel RF connector will drop by about 15 dB.

Power leveling

Power leveling is not available when operating at banded millimeter-wave frequencies. (Please see *Power control* in this document for more information.)

Expected output power

For each test head module shipped, OML ships along a plot of its output power vs. frequency at the waveguide interface. These values vary depending on the frequency band of interest.

IF BW selection

For optimal performance at millimeter-wave frequencies, it is recommended that the IF BW be no wider than 1 kHz, preferably 10 Hz. Otherwise, traces can be noisy.

Resolution of frequency source

Only Agilent PSG sources are supported. Because frequency up-conversions done in the test heads require high harmonic multipliers (higher multipliers for higher frequency bands, see Table 4 for details), it is necessary for external synthesizers to have precision to sub-Hz resolution level. If 1-Hz resolution sources are used, errors can propagate resulting in sizable frequency errors.

Frequency resolution of the PSG Series (CW) is 0.001 Hz.

PNA 1st IF = 8.333333... MHz

IF = N*rf +/- M*LO

Example:

RF = 110 GHz (*measurement frequency of WR-10*)

N = 6 (from Table 4)

rf = RF / N = 110 GHz / 6

rf = 18.33333333... GHz (*frequency of external RF source*)

M*LO = IF + N*rf

M*LO = 8.333333... MHz + 110 GHz = 110008333333.333... Hz

M = 8 (from Table 4)

LO = 110008333333 Hz / 8

LO = 13751041666.625 Hz (*frequency of external LO source*)

As you can see, due to the unique value of the PNA 1st IF, the values needed for the external RF and LO synthesizers are most likely never to be whole numbers. Therefore, it is necessary for external synthesizers to have sub-Hz resolution in order to yield an accurate PNA 1st IF.

Multiple channels

Using multiple channels is not supported when operating in external synthesizer configuration. This is primarily because when switching from one channel to the next, the PNA has to download all the necessary information to the PSGs before starting a sweep. Timing differences between channel switching (within the PNA) and signals within the trigger chain (outside the PNA) could result in erroneous data collection for the trace being swept.

System Calibration (error-correction)

Choosing the right calibration technique

Applicable calibration techniques depend on the system (hardware) configuration. Table 6 shows the available calibration techniques for two possible system configurations: one with two T/R modules, and the second with one T/R module and one T module. Depending on the technique chosen, the calibration interface on the PNA may be different.

Table 6. Combination of test head modules and applicable calibration techniques.

| | System configurations | | | | Calibration interface | |
|-------------------|---|--------------------|--|-----|----------------------------------|-------------------------|
| | Configuration #1 ¹ | | Configuration #2 ² | | SmartCal (guided calibration) | Unguided calibration |
| | Two T/R modules (S-parameter test set) | | One T/R module and one T module (transmission/reflection (T/R) test set) | | | |
| OPEN Response | √ | S11 OR S22 | √ | S11 | | √ |
| SHORT Response | √ | S11 OR S22 | √ | S11 | | √ |
| THRU Response | √ | S21 OR S12 | √ | S21 | | √ |
| 1-Port Reflection | √ | S11 OR S22 | √ | S11 | √ | √ |
| Full SOLT 2-Port | √ | S11, S21, S12, S22 | | | √ | √ |
| Full TRL 2-Port | √ | S11, S21, S12, S22 | | | √ | √ |

1. See Figure 4a.
2. See Figure 4b.

Each N5260AWxx includes a pair of T/R test head modules (configuration #1) and the respective WG calibration kit. With this, the setup would allow for measurements of S11, S21, S12 and S22. Plus, full 2-port calibration is possible with SOLT, and TRL.

With configuration #2, although the setup only allows for measurements of S11 and S21, the user can perform either 1-port calibration for S11, or thru response calibration (normalization) for S21, or *append* the latter calibration to the previous thus creating one calset for both traces within one measurement channel¹. Here are the steps to append two calibrations:

- With trace S11 active, perform 1-port calibration using SmartCal, then click **Save As User CalSet** to finish
- With trace S21 active (in the same channel), while the 1-port calibration is selected, perform response calibration (or normalization) using Unguided Cal, then click **Save As User CalSet** to finish – but make sure the selected calset is the same one as the currently active 1-port cal – click **Save** to complete
- As the final step, the Calibration Wizard will then ask if appending this calibration to the existing one is desired, as shown in Figure 11, simply click **OK** to confirm. Once finished, the same calset will cover both calibrations, 1-port for S11 and thru response for S21. This way, when you click on S11, the status bar (located on the bottom of the display) shows **C 1-Port**, and when you click on S21, it shows **C Response**.

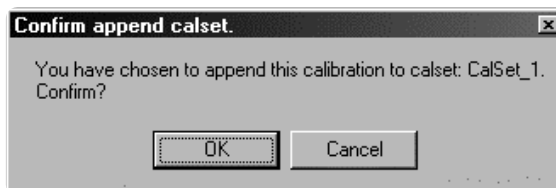

Figure 11. Appending a calibration to an existing CalSet.

Each WG calibration kit from OML comes with the following standards and a floppy disk loaded with the calibration definition file formatted for the PNA:

- Precision Terminations, Fixed Loads, qty 2
- Precision (flush) Shorts, qty 2
- Precision Insert A (line1), Null Shim
- Precision Insert B (line2), ¼ Offset Shim
- Adjustable Load
- Precision Section

Note

Setting System Z_0 to 1- Ω :
When performing *Unguided* calibration with waveguide interface, the user must manually set the System Z_0 to 1- Ω to match the waveguide kit. This is because *Unguided* calibration uses System Z_0 during calibration computation. Whereas, SmartCal uses the Z_0 defined by the connector definition and is applied automatically during calibration.

System > Configure > System Z0

Enter a value of 1 for waveguide, then click **OK**.

1. Enhanced-response calibration is currently not available.

Loading and checking calibration definition file

Each PNA is shipped with calibration definition files from Agilent calibration kits. For non-Agilent calibration kits such as the WG calibration kits from OML, the user must first load the file and then check to make sure all the items are in order. (The user can also choose to create his own WG cal kit file if desired. Refer to Appendix A for details.)

Calibration > Advanced Modify Cal Kit ... > Import Kit ...

Use dropdown menu to select "3½ Floppy (A:)"

Highlight the file to be imported, and click **Open**

Once the file is loaded, it will appear on the list of **Installed Kits** as shown in Figure 12. Highlight the file of interest, (The example shows **V05_OML**.) and click **Edit Kit ...** in order to view the kit definition. On this page, you can see all the standards (and combinations) as defined for this particular WG calibration kit.

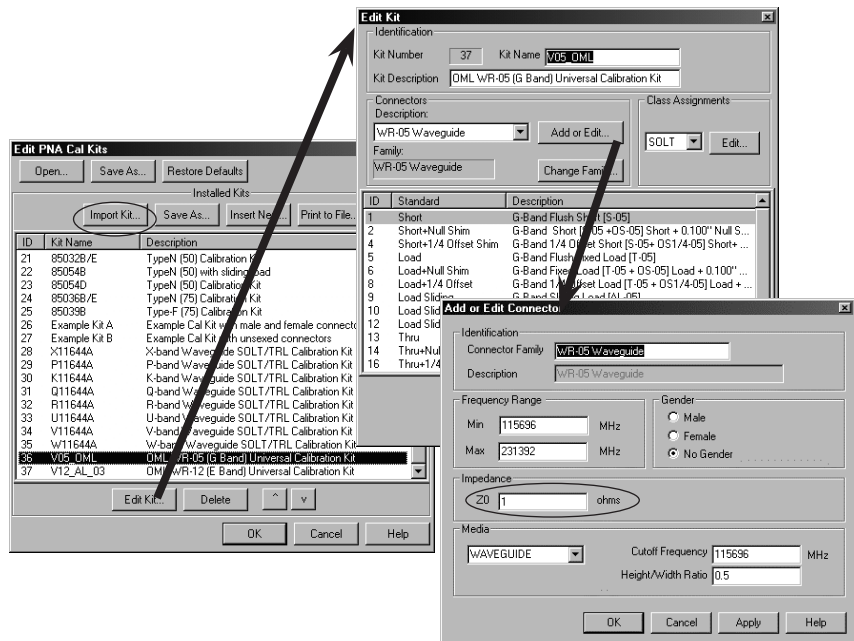

Figure 12. Loading the calibration definition file and checking on the connector definition.

The examples in Figure 14 show the standards and class assignments for both TRL and SOLT. These are defined as shown in Table 7. Figure 15 shows examples of the details of each standard definition.

Table 7. Standards and class assignments of TRL and SOLT calibrations.

| | Class Assignments | Class Label | Selected Standards |
|------|-------------------|-------------|-----------------------|
| TRL | TRL THRU | THRU | Thru + Null Shim |
| | TRL REFLECT | REFLECT | Flush Short |
| | TRL LINE/MATCH | LINE | Thru + ¼ Offset Shim |
| SOLT | S11A, S22A | OPENS | Short + Null Shim |
| | S11B, S22B | SHORTS | Short + ¼ Offset Shim |
| | S11C, S22C | LOADS | Flush Fixed Load |
| | FWD TRANS | THRU | Thru |

Thru-reflect-line (TRL) calibration:

Setting test port reference plane

Two selections are available for setting the test port reference plane; **Thru Standard** or **Reflect Standard** (see Figure 13). If a flush short is used for the reflect standard, then select the "Reflect Standard" for the "Test port Reference Plane". A flush short provides a much more accurate phase reference than a thru standard.

Short-open-load-thru (SOLT) calibration:

Adjustable load

Although an adjustable load is shipped in each WG calibration kit from OML, this standard is not ideal for millimeter-wave frequencies because mechanical tolerances make obtaining repeatable results difficult. Plus, adjustable loads are best if step sizes can be varied from large to small as one tries to trace out circles on a smith chart. Given the frequency ranges of these calibration kits, it would be very challenging to produce repeatable results. Therefore, fixed loads are used for the load standards for SOLT.

Offset load

Offset load is available in the PNA with firmware 6.0. Using offset load can result in a more accurate calibration than with broadband load, but it does require extra connections. A typical offset load requires two known offsets along with a load element. As such, one connection is made using the *first offset with the load*, and the other one is made using the *second offset with the load*. Figure 13 shows a definition of an offset load.

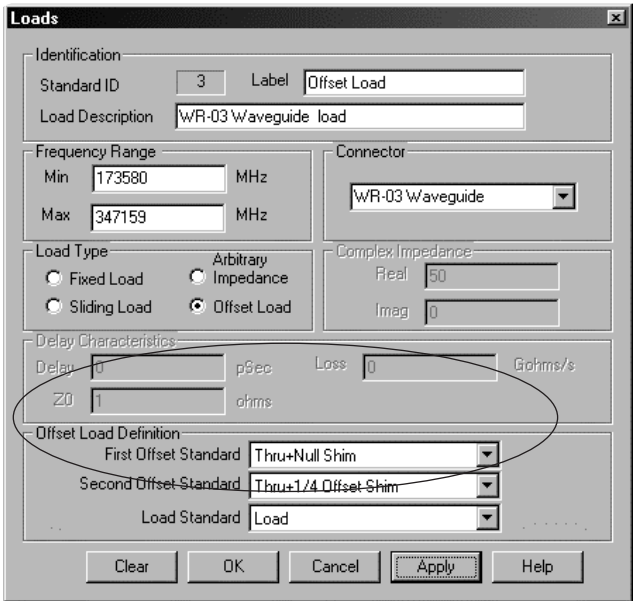

Figure 13. Example of an offset load definition.

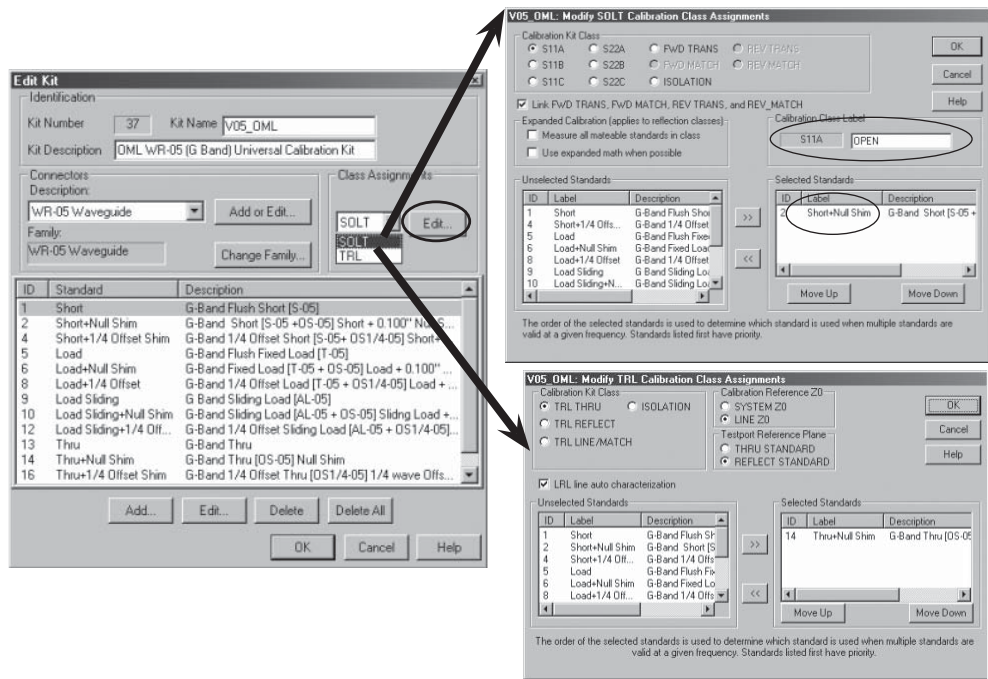

Figure 14. Examples of TRL and SOLT class assignments.

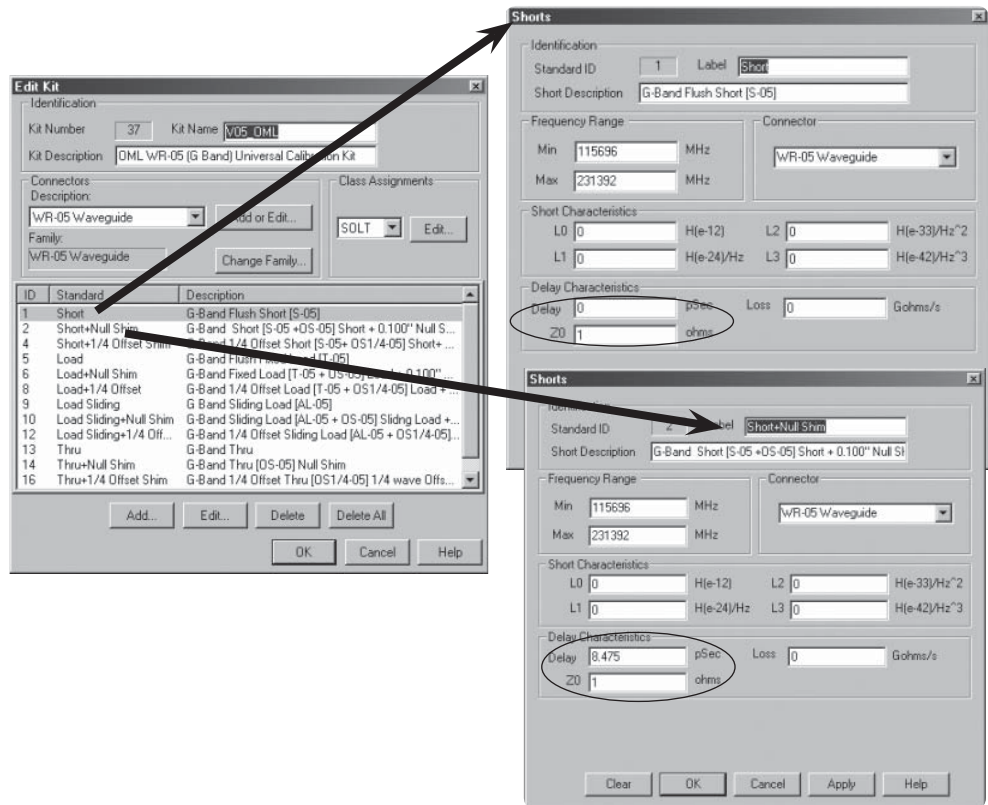

Figure 15. Examples of standards definitions. Key parameters to check included Min and Max of Frequency Range, as well as Delay and Z_0 .

Configuration #1: Two T/R Modules (S-parameter test set)

With a full 2-port calibration, this configuration allows one to measure all four S-parameters (S11, S21, S12, S22). Full 2-port calibrations are available in either TRL or SOLT. These calibrations are available under *SmartCal* (guided) or *Unguided* calibrations on the PNA under *Calibration Wizard*.

Note

TRL calibration

TRL only requires four steps. It requires one reflect standard for each test port, one thru and one line (a section with a defined length).

- The reference must be established by the SHORT (reflect) standard.
- The impedance selected must be LINE Z_0 .

These are the default settings when using *SmartCal*. When using *Unguided* calibration, the user must check to confirm these settings, as well as setting system Z_0 to 1- Ω (**System > Configure > System Z_0**).

SOLT calibration

SOLT requires seven steps, three more steps than TRL! It requires three standards for each test port, and one thru.

Unknown Thru is available, but only with SOLT. Since SOLT takes more steps and is less accurate than TRL, the only time you should consider performing SOLT calibration is to

benefit from an Unknown Thru. One such situation may be where the test heads are restricted from movement (such as bolted down to avoid cable movements); in such a case, an Unknown Thru would be very useful as it would eliminate the need to move them. Another example is when the test port cables are at 90 degrees, preventing a straight thru from being connected.

When SOLT is needed, using offset load (instead of fixed load) will result in a more accurate calibration. This may require you to modify a cal kit definition as well as performing more connections during the actual calibration.

Example #1: WR-12, 60 to 90 GHz

- Equipment: E8364B with Options 014, UNL, 080, 081, H11
 N5260A test set controller
 WR-12 (60 to 90 GHz) T/R test heads modules
- Setup: IF BW: 100 Hz
 Number of Points: 201
- Calibration: Channel 1: SmartCal, 2-port, Flush Thru, TRL

For 2-port calibrations in waveguide, SmartCal defaults to TRL with Flush Thru. Figure 16 shows that the system dynamic range is better than 90 dB and trace noise is better than ± 0.10 dB.

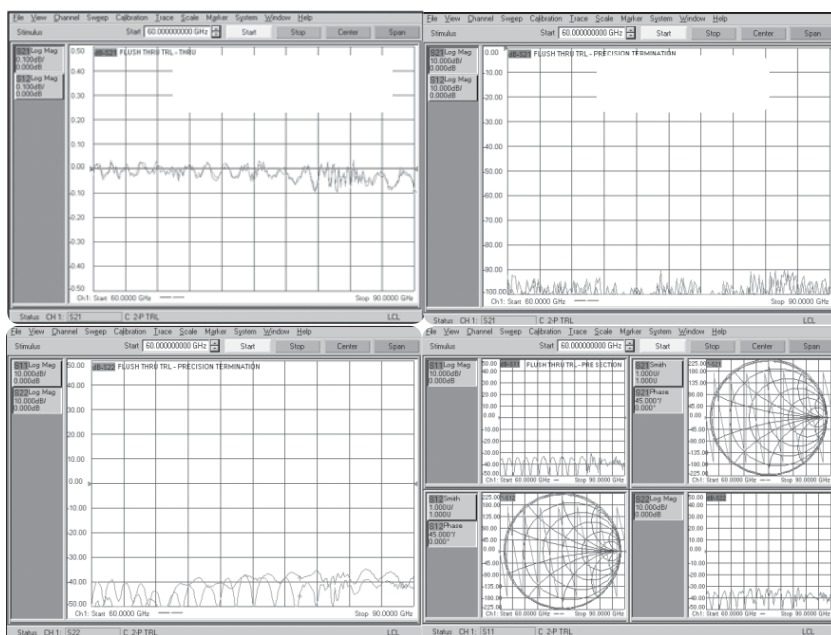

Figure 16. WR-12, 60 to 90 GHz, Flush Thru TRL calibration results.

Configuration #2: One T/R module and one T module (T/R test set)

This configuration allows you to measure only two S-parameters (S11 and S21). For simultaneous corrected measurements of both parameters, one can perform a 1-port calibration for trace S11 and then append the thru response calibration (or normalization) performed for trace S21; thus, resulting in one calset for both traces.

1-port calibrations are available under SmartCal (guided) or unguided calibrations, while Thru Response calibrations (or normalization) are only available under unguided calibrations (see Table 6).

Example #2: WR-05, 140 to 220 GHz
 Equipment: E8364B with Options 014, UNL, 080, 081, H11
 N5260A test set controller
 WR-05 (140 to 220 GHz) T/R and T test head modules
 E8257D with Options 520 and UNR (Qty of 2)
 Setup: IF BW: 10 Hz
 Number of Points: 201

For the frequency range of 140 to 220 GHz, Figure 17 compares dynamic range and Figure 18 compares trace noise (for S21). In both cases, using Agilent PSG Series as external synthesizers to improve performance. For dynamic range, the improvement was up to 10 dB on average; for trace noise, it went from less than 0.05 dB around 220 GHz to practically non-existence!

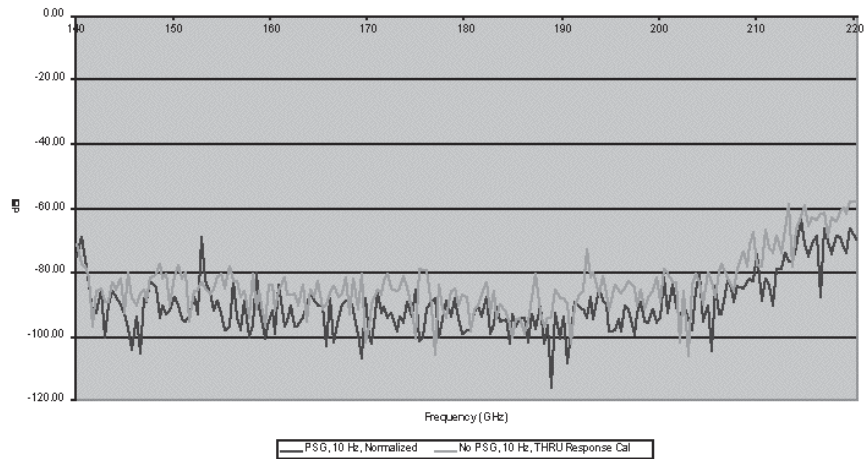

Figure 17. WR-05, 140 to 220 GHz, T/R and T modules. Dynamic range comparison between measurements made with external synthesizers and without.

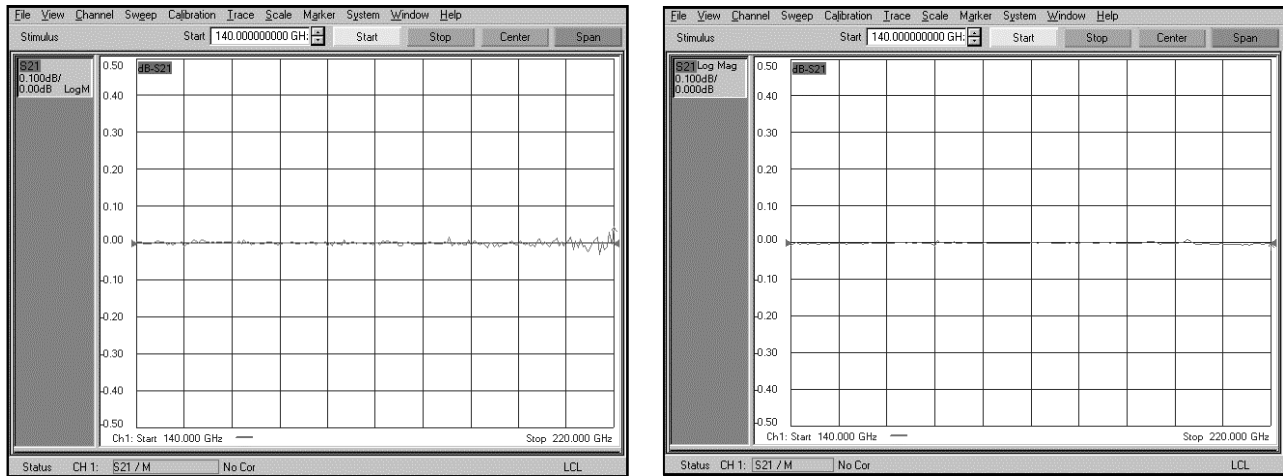

Figure 18. WR-05, 140 to 220 GHz, trace noise comparison between measurements made with external synthesizers (right) and without (left). Both plots have the same scale, 0.10 dB per division.

Example #3: WR-03, 220 to 325 GHz
 Equipment: E8364B with Options 014, UNL, 080, 081, H11
 N5260A test set controller
 WR-03 (220 to 325 GHz) T/R and T test head modules
 E8257D with Options 520 and UNR (Qty of 2)
 Setup: IF BW: 10 Hz
 Number of Points: 201

For the frequency range of 220 to 325 GHz, Figure 19 compares dynamic range and Figure 20 compares trace noise (for S21). Similar to the previous example (WR-05), using Agilent PSG Series as external synthesizers do improve performance in both cases. However, the improvement for this higher frequency range is much more significant. For dynamic range, the improvement was up to 20 dB on average; for trace noise, it went from less than 0.20 dB around 300 GHz to less than 0.02 dB – that’s an improvement of at least ten times!

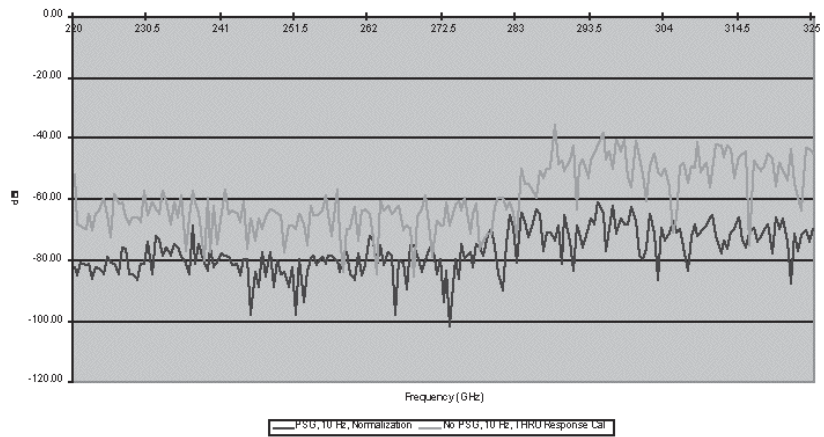

Figure 19. WR-03, 220 to 325 GHz, T/R and T modules. Dynamic range comparison between measurements made with external synthesizers and without.

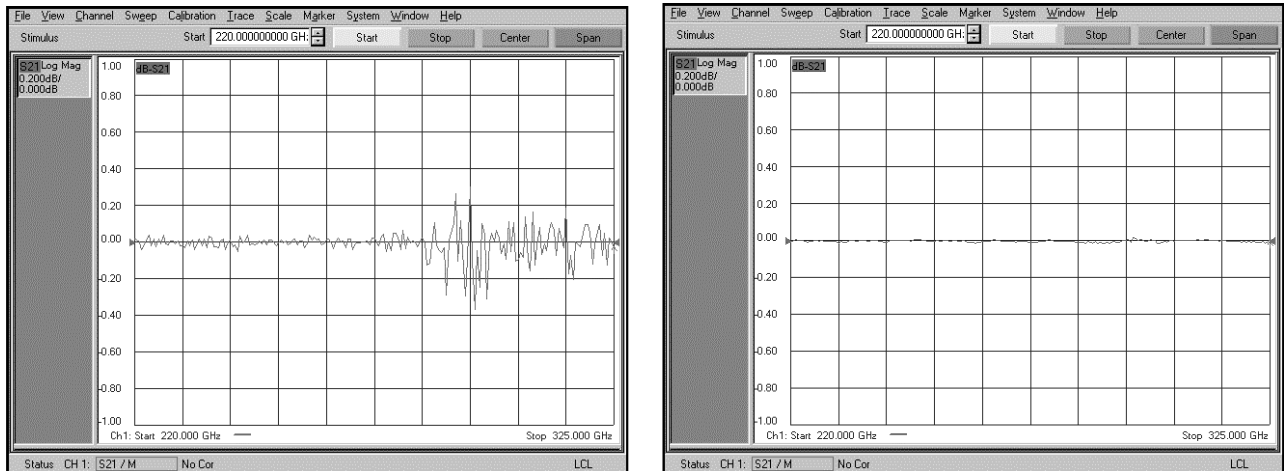

Figure 20. WR-03, 220 to 325 GHz, trace noise comparison between measurements made with external synthesizers (right) and without (left). Both plots have the same scale, 0.20 dB per division.

Application Examples

Example #1: Antenna measurements

Below are two examples of antenna configurations. For more details, please refer to the *Agilent Antenna Test – Selection Guide*, literature number 5968-6759E or visit our web site at www.agilent.com/find/antenna

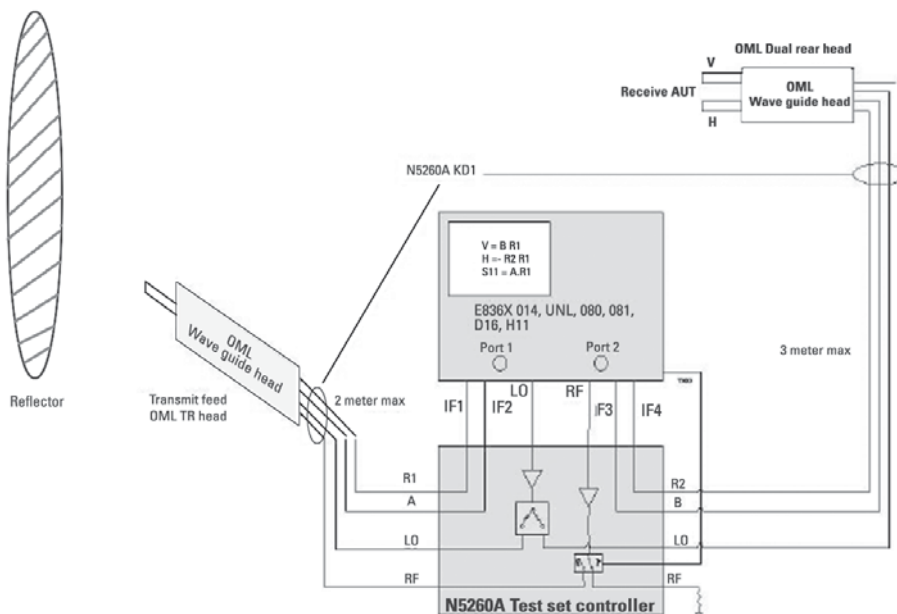

Figure 21. PNA banded millimeter-wave solution applied to *indoor* antenna measurements. The transmit side (left) uses an OML T/R module, and the receive side (right) uses the OML Dual T module. Dual T modules are ideal for measuring both vertical and horizontal polarities of the antenna.

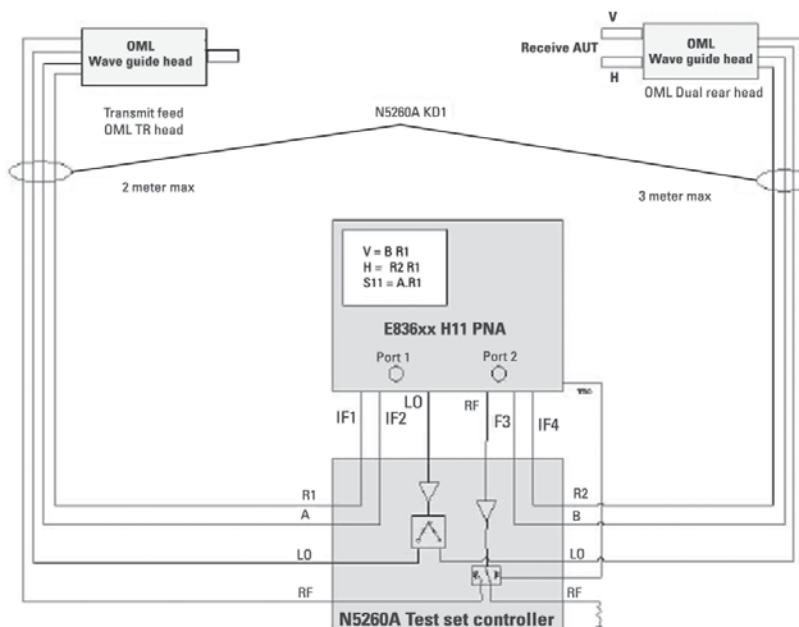

Figure 22. PNA banded millimeter-wave solution applied to *outdoor* antenna measurements. The transmit side (left) uses an OML T/R module, and the receive side (right) uses the OML Dual T module. Dual T modules are ideal for measuring both vertical and horizontal polarities of the antenna.

Example #2: Pulsed measurements

In a banded millimeter-wave configuration, the pulse modulator can be applied to the RF signal coming from either the front of the N5260A millimeter-wave controller or the rear of the PNA. In either case, a dual output pulse generator (Agilent 81110A) will be needed to provide a pulse drive to the modulator as well as the B gate of the PNA. Measurements of point-in-pulse and pulse profiling have been performed for V-band (50 to 75 GHz) and W-band (75 to 110 GHz).

Figure 23 shows the pulse modulator (Agilent Z5623AH81) being placed between the front of the N5260A millimeter-wave controller and the test head module. Since this pulse modulator is unidirectional, this is connected to the port 1 path only. In this configuration, the modulator takes the CW signal coming out of the front of the N5260A and provides a pulsed-RF signal going into the test head module of port 1 and it will in turn deliver a pulsed-RF stimulus to the device-under-test (DUT).

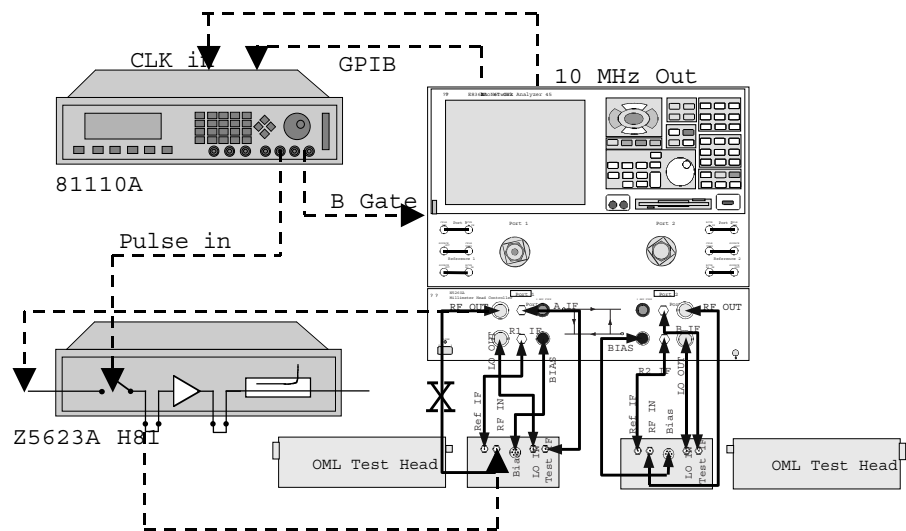

Figure 23. Pulsed the RF signal coming from the front of the N5260A millimeter-wave controller.

Example #3: Materials measurements

Figure 26 shows one example configuration of materials measurement in W-band, 75 to 110 GHz. This application requires two W-band waveguide horns and alignment of the test heads in order to transmit and receive test signals. In addition, using the measurement software shown requires two T/R test heads (an S-parameter setup). For more details, please visit our web site at www.agilent.com/find/materials

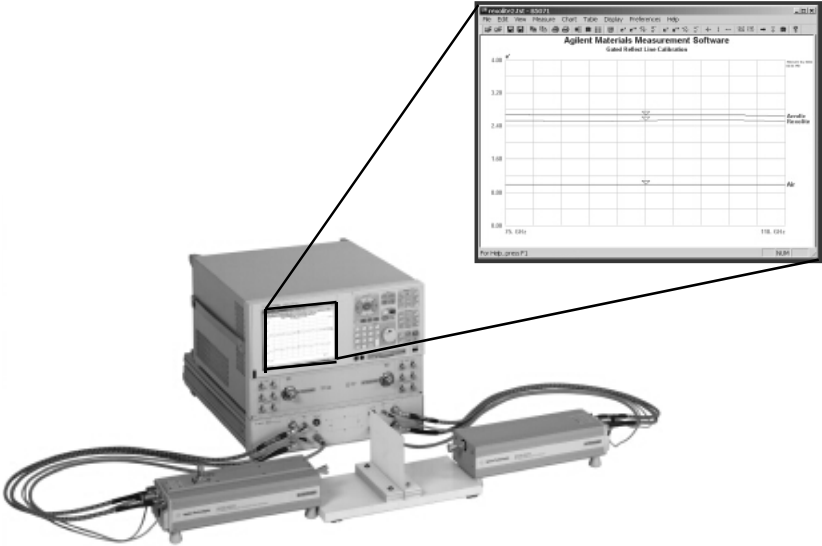
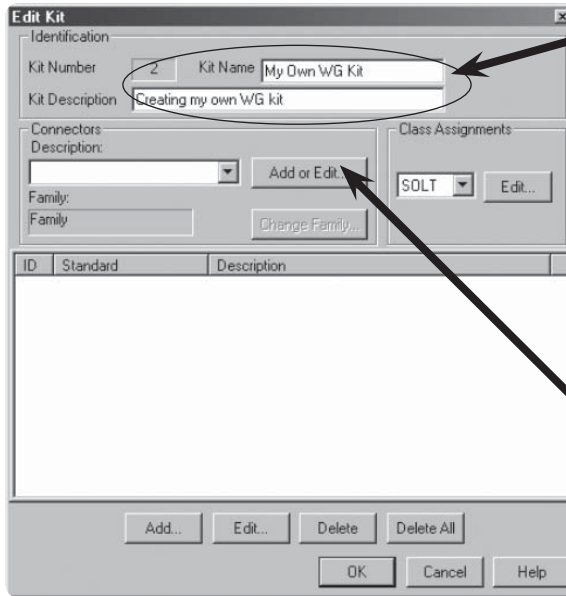

Figure 26. Using materials measurement software and Free Space Calibration technique to perform materials measurements in millimeter-wave. Insert shows measurement software interface.

Appendix A: Creating Your Own Waveguide (WG) Calibration Kit Definition

1. **Calibration > Advanced Modify Cal Kit > Insert New**
2. Enter "Kit Name" and "Kit Description" and then click on "Add or Edit" to enter connector information (Figure 27)



Enter "Kit Name" and "Kit Description." ("Kit Name" will appear on the list of "installed kits" next time you click on "Advanced Modify Cal Kit".)

Click on "Add or Edit" to enter connector information

Figure 27. Enter calibration kit name.

3. Enter "Connector Family," "Frequency Range" (Min. frequency = Cutoff frequency), 1 for "Z0;" select "No Gender," and "WAVEGUIDE" (Figure 28)

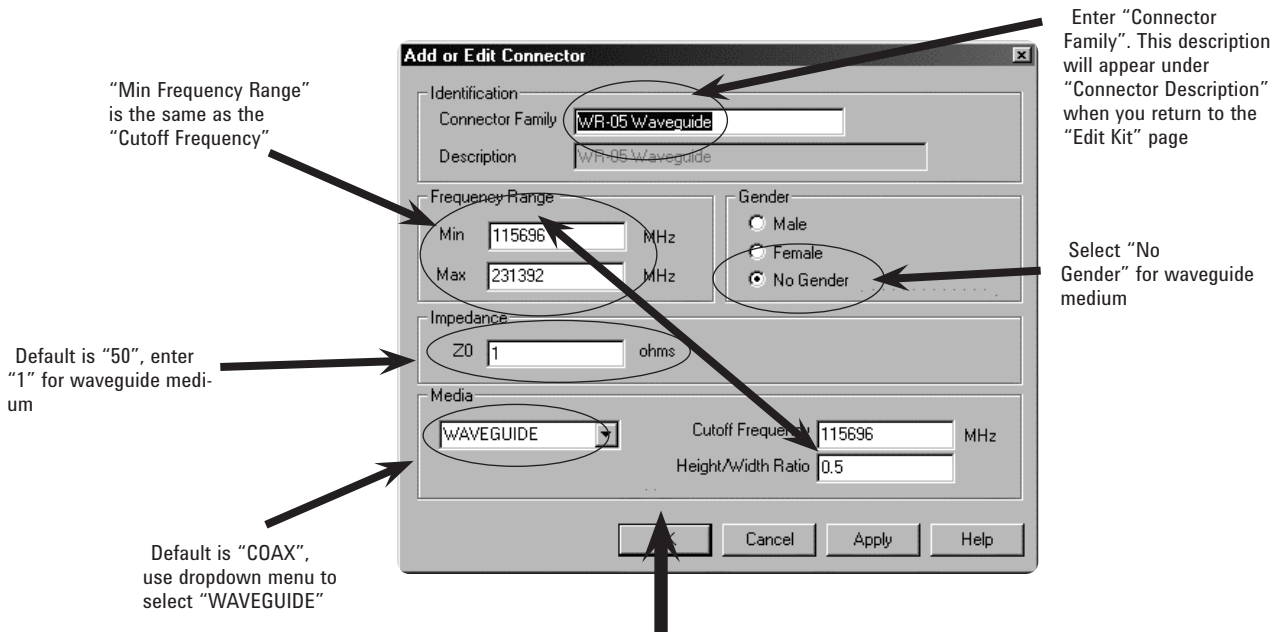

Figure 28. Enter connector (WG) description.

- Click **OK**. This returns to the “Edit Kit” page (name of the page is shown on the upper-left corner of the dialog box). Click “Add” to start adding standards (Figure 29).

Clicking OK (on the “Add or Edit Connector” page) returns to the “Edit Kit” page and the connector information appears.

Click “Add” to start adding stand-

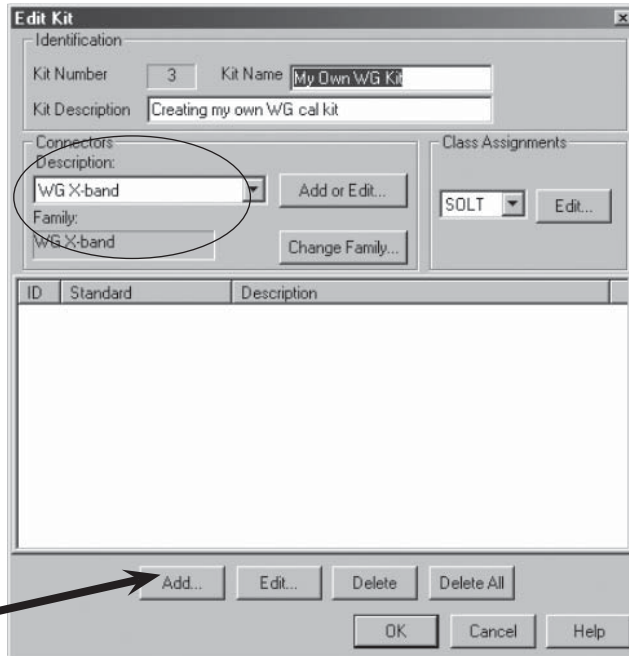

Figure 29. Completed connector description, and start adding standards.

- For waveguide, the best calibration technique may be thru-reflect-line (TRL). There is almost no reason to use SOLT since TRL is more accurate and SOLT requires more steps. Thus, for TRL or its variation such as line-reflect-line (LRL), you may want to add the following standards:

| | | |
|-----|---------|--|
| TRL | THRU | Thru (0 delay) |
| | REFLECT | Flush Short (0 delay) |
| | LINE | Thru with offset (a known delay) |
| LRL | LINE 1 | Thru with offset 1 (a known delay) |
| | REFLECT | Flush Short (0 delay) |
| | LINE 2 | Thru with offset 2 (a different known delay) |

However, if SOLT is needed, offset load can be used in place of fixed load. Using offset load will result in a more accurate calibration than with broadband load, and below are the standards needed:

| | | |
|------|-------------|--|
| SOLT | Short | Flush Short |
| | Open | Flush Short and Offset |
| | Offset Load | Load with Offset 1 (a known delay) |
| | | Load with Offset 2 (a different known delay) |
| | Thru | Thru (0 delay) |

Select a standard by clicking on it, the example shows SHORT (Figure 30, left). This brings up the “Shorts” page. The key parameters to note are the frequency range, the delay value if applicable, and the value of Z0 (Figure 30, right). Click OK when done, and this returns to the “Add Standard” page. Repeat this step until all standards have been added. Figure 31 shows adding a THRU standard.

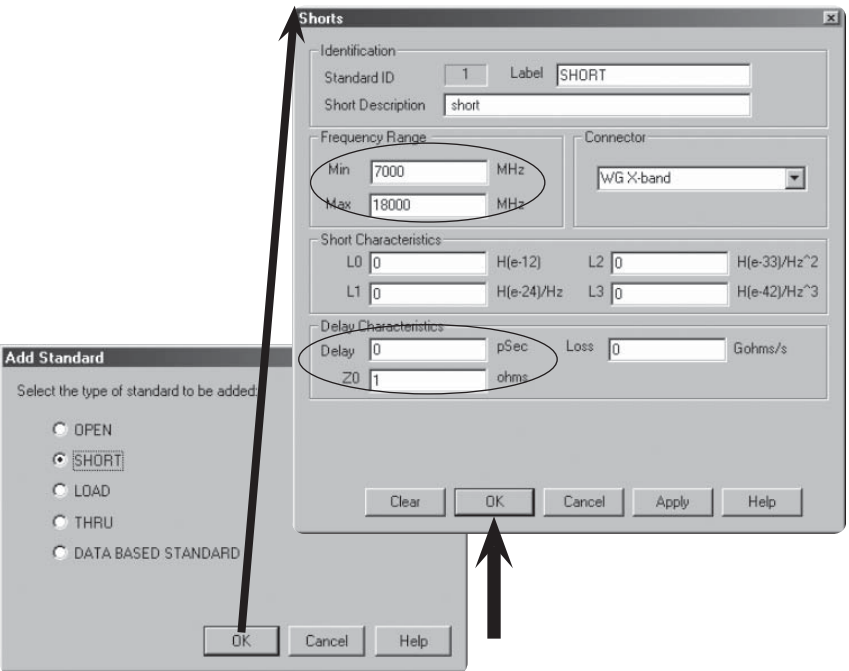

Figure 30. Add a SHORT standard.

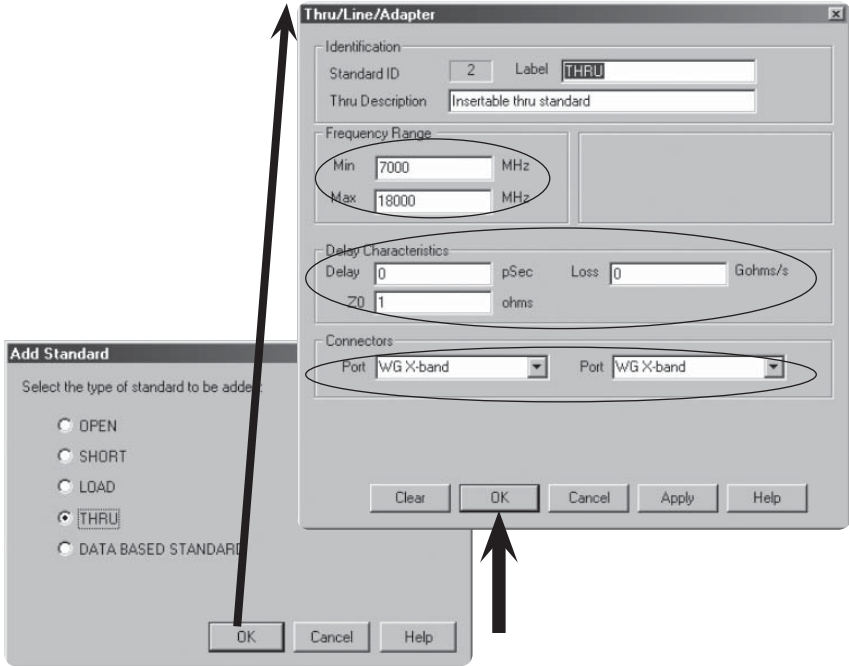

Figure 31. Adding a THRU standard.

Once you have added at least one fixed load and two offsets of different length, you can then define an offset load. Figure 32 shows the "Loads" page, and the default of this page is "Fixed Load." When "Offset Load" is selected, the "Offset Load Definition" area becomes active and you must use the dropdown menu to select each standard element. The "Delay Characteristics" area then becomes inactive because this is applicable for "Fixed Load."

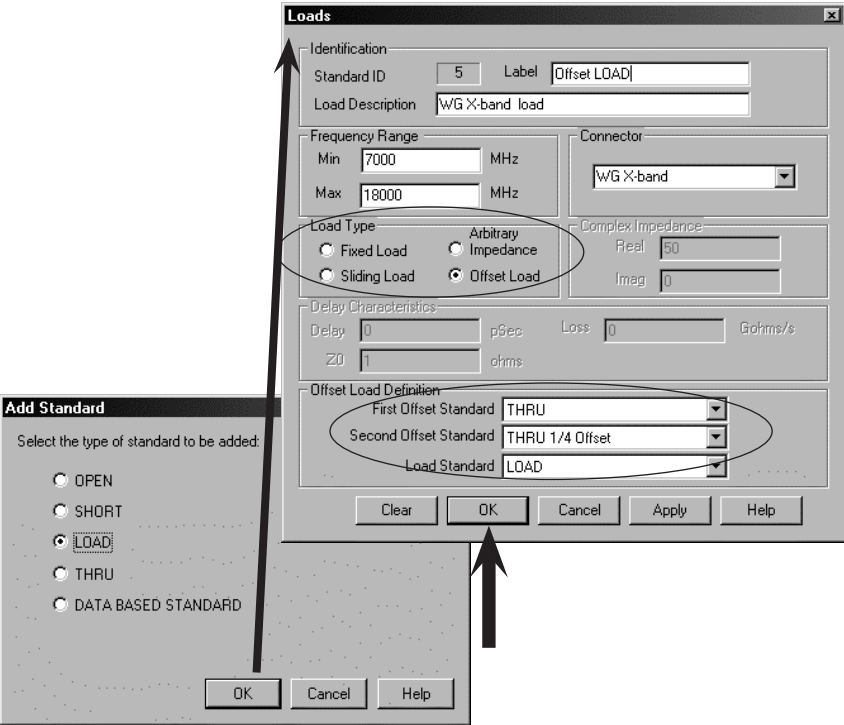

Figure 32. Adding an Offset Load standard.

6. After all standards have been added, click **OK** on the “Add Standard” page to return to the “Edit Kit” page. All the standards that have been added should appear in the table (Figure 33, left). Now, under “Class Assignments”, use the drop down menu to select “TRL” (or “SOLT”) and then click on **Edit**. This brings up the “Class Assignments” page, Figure 33 (right) shows “Class Assignments” for TRL. For each “Class” selected, highlight the standard on the left, and then click on the “>>” button in the middle, to move the standard to the right under “Selected Standards.”

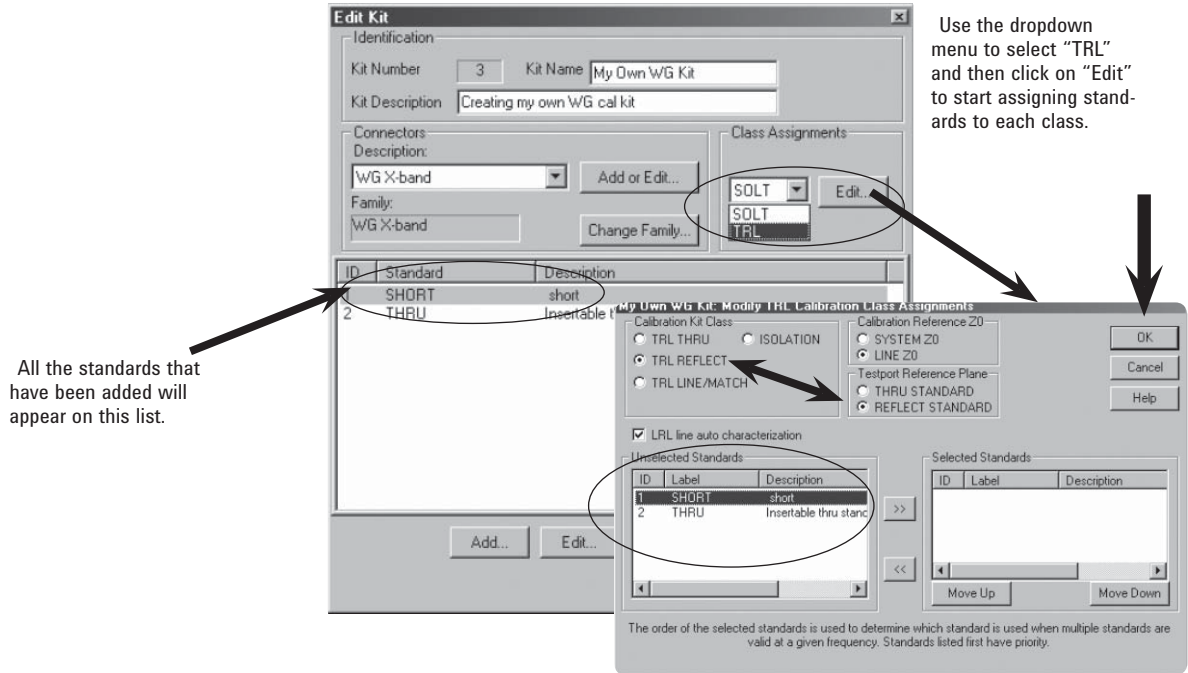

Figure 33. Assigning standards to class TRL.

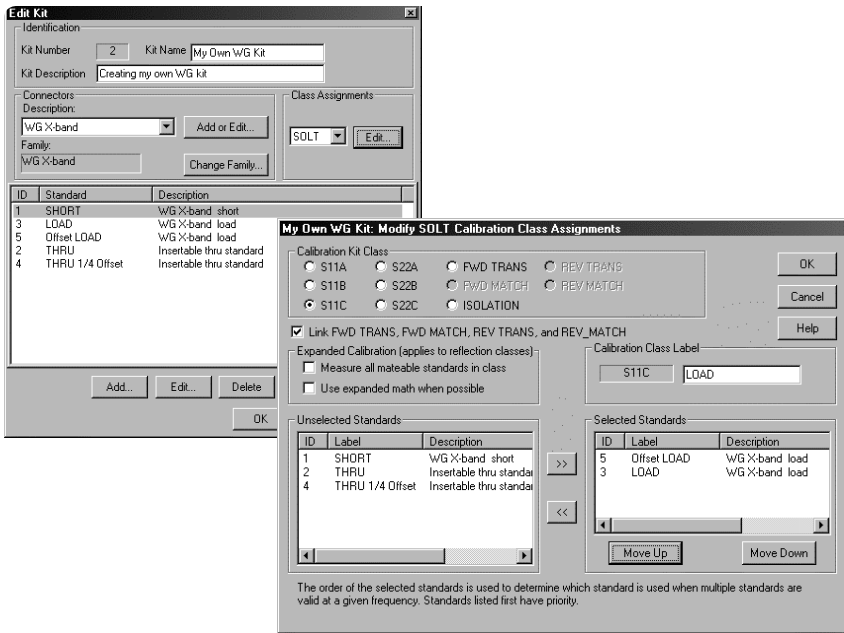

Figure 34. Assigning standards to class SOLT (with Offset Load).

7. Click **OK** when done to return to the “Edit Kit” page, and then click **OK** again to return to the “Edit PNA Cal Kits” page. At this point, you should be able to see the kit that you just created under the list of “Installed Kits” (Figure 35).

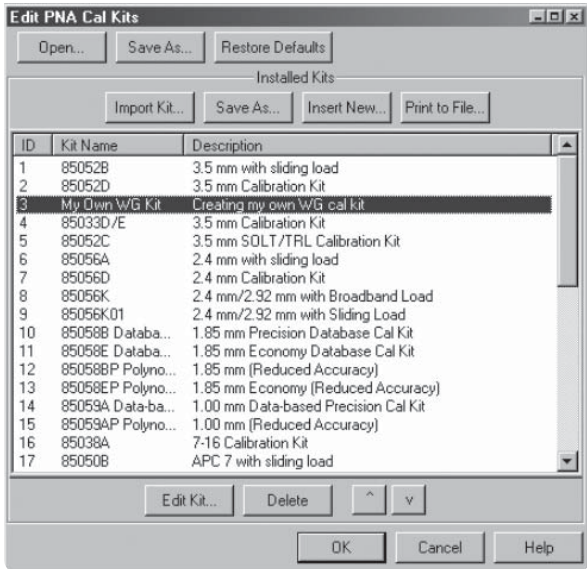

Figure 35. Calibration kit file created, done!

8. Congratulations! You are now ready to calibrate in waveguide.

Appendix B: Performing Calibrations

I. SmartCal, 2-port calibration

1. Calibration > Calibration Wizard ...
2. Select **SmartCal (GUIDED Calibration)**, then click **Next>** (Figure 36, top)
3. Select **Cal Type**, click **Next>** (Figure 36, middle)
4. Use dropdown menu and then the scroll bar to select the DUT connectors (Figure 36, bottom). Also, use dropdown menu to select the available calibration kit based on the selected DUT connectors. Notice, the default *Cal Method* is *2-Port, Defined Thru, TRL*. Plus, if "Modify Cal" is not selected, then steps shown in Figure 37 will be skipped. Click **Next>**

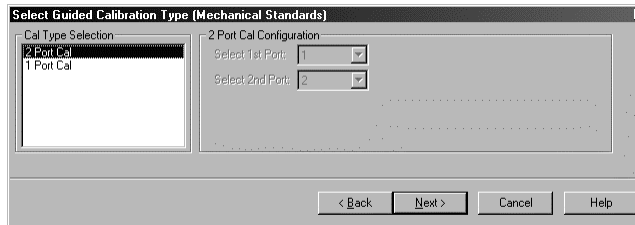
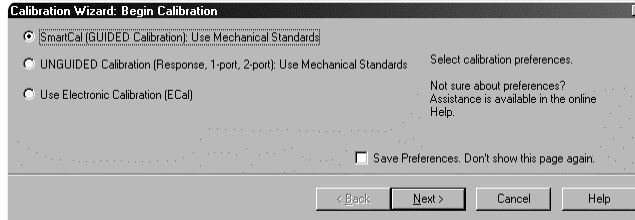

Use dropdown menu to select DUT connectors.

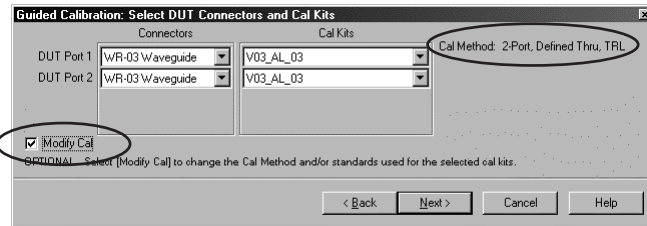

Selecting "Modify Cal" will show steps in Figure 36.

Figure 36. Select SmartCal and DUT connectors.

5. Having selected "Modify Cal" allows you to change the *Cal Type*. Figure 37 (top) shows *Cal Type: TRL*, you can click **Mod Stds**, and then use the dropdown menu on the right to select a different cal type. Figure 37 (middle) shows the selection of **SOLT**. Clicking **OK** returns you to the previous screen, and this time it shows the *Cal Type: SOLT* (Figure 37, bottom).

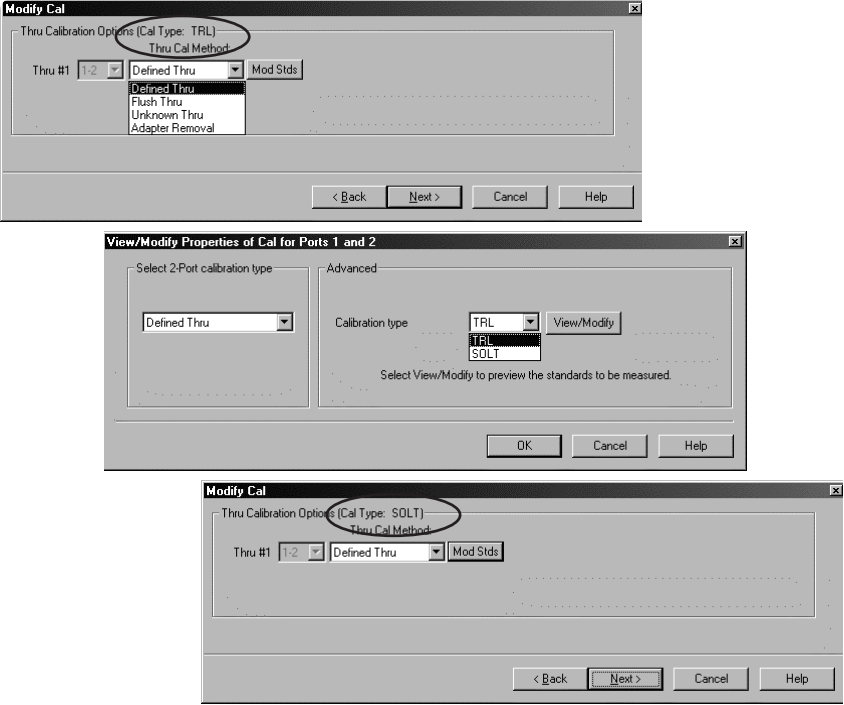

Figure 37. Changing *Cal Type*.

6. The calibration has now begun. As shown on the upper-left corner of each screenshot (Figure 38), the 2-port, Flush Thru, TRL calibration includes four steps. The example shown here is based on using an OML cal kit.

- Step 1 of 4: Port 1, Short
- Step 2 of 4: Port 2, Short
- Step 3 of 4: Port 1, THRU + NULL Shim, Port 2
- Step 4 of 4: Port 1, THRU + ¼ Offset Shim, Port 2

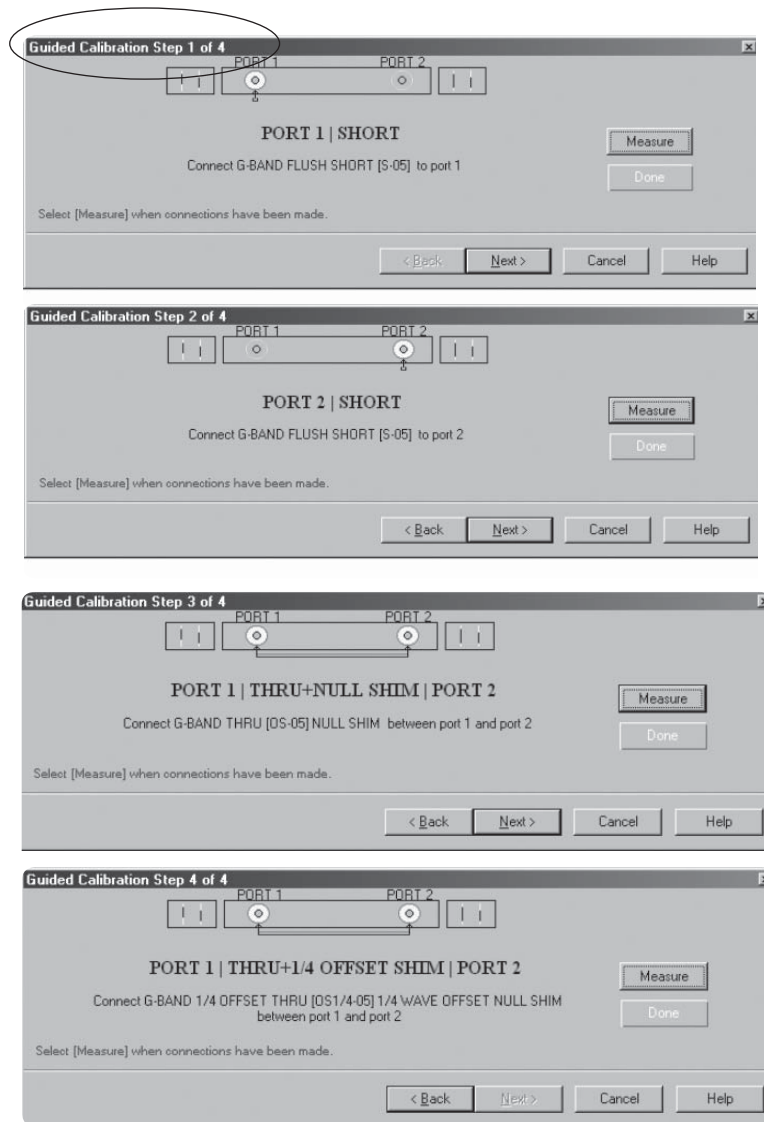

Figure 38. Steps of the 2-port, Flush Thru, TRL calibration (using an OML cal kit).

7. Congratulations! You have just completed a 2-port, Flush Thru, TRL calibration.

Alternatives:

Using an OML calibration kit, performing an SOLT calibration with Offset Load would require 9 steps:

- Step 1 of 9: Port 1, Short + NULL Shim
- Step 2 of 9: Port 1, Short + 1/4 Offset Shim
- Step 3 of 9: Port 1, THRU + NULL Shim, Load
- Step 4 of 9: Port 1, THRU + 1/4 Offset Shim, Load
- Step 5 of 9: Port 2, Short + NULL Shim
- Step 6 of 9: Port 2, Short + 1/4 Offset Shim
- Step 7 of 9: Port 2, THRU + NULL Shim, Load
- Step 8 of 9: Port 2, THRU + 1/4 Offset Shim, Load
- Step 9 of 9: Port 1, Port 2

Using an OML calibration kit, performing an SOLT calibration with fixed Load would require 7 steps:

- Step 1 of 7: Port 1, Short + NULL Shim
- Step 2 of 7: Port 1, Short + 1/4 Offset Shim
- Step 3 of 7: Port 1, Load
- Step 4 of 7: Port 2, Short + NULL Shim
- Step 5 of 7: Port 2, Short + 1/4 Offset Shim
- Step 6 of 7: Port 2, Load
- Step 7 of 7: Port 1, Port 2

II. SmartCal, 1-port calibration

1. **Calibration > Calibration Wizard ...**
2. Select **SmartCal (GUIDED Calibration)**, then click **Next>** (Figure 39, top)
3. Select **Cal Type**. Notice on the right that you can choose either Port 1 or Port 2 as the test port for the 1-port calibration. Then, click **Next>** (Figure 39, middle)
4. Use dropdown menu and then the scroll bar to select the DUT connectors (Figure 39, bottom). Also, use dropdown menu to select the available calibration kit based on the selected DUT connectors. Notice, the *Cal Method* here is simply *1-Port*. Plus, if "Modify Cal" is not selected, then steps shown in Figure 40 will be skipped. Click **Next>**

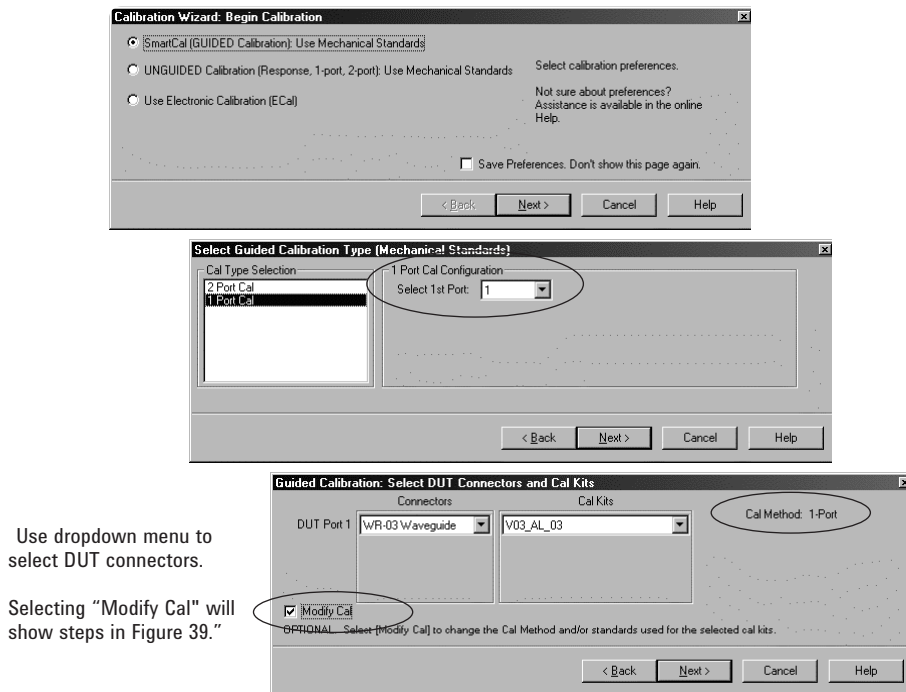

Use dropdown menu to select DUT connectors.

Selecting "Modify Cal" will show steps in Figure 39."

Figure 39. Select SmartCal and DUT connectors.

5. Having selected "Modify Cal" allows you to look at the screens shown in Figure 40. However, in the case of 1-port calibrations, you are limited to SOL calibration only. Thus, clicking on "Modify Cal" does not offer you additional selection. Your *Cal Type* remains as *One Port*.

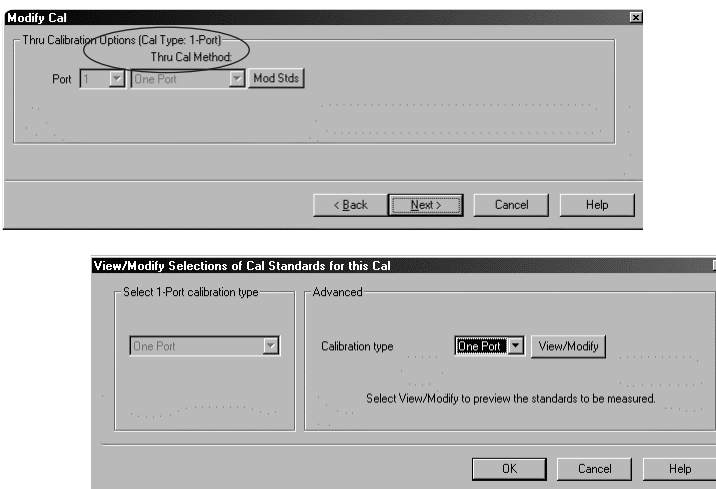

Figure 40. Viewing *Modify Cal* displays.

6. The calibration has now begun. As shown on the upper-left corner of each screenshot (Figure 41), the 1-port calibration includes three steps. The example shown here is based on using a OML cal kit.

- Step 1 of 3: Port 1, Short + Null Shim
- Step 2 of 3: Port 1, Short + ¼ Offset Shim
- Step 3 of 3: Port 1, Load

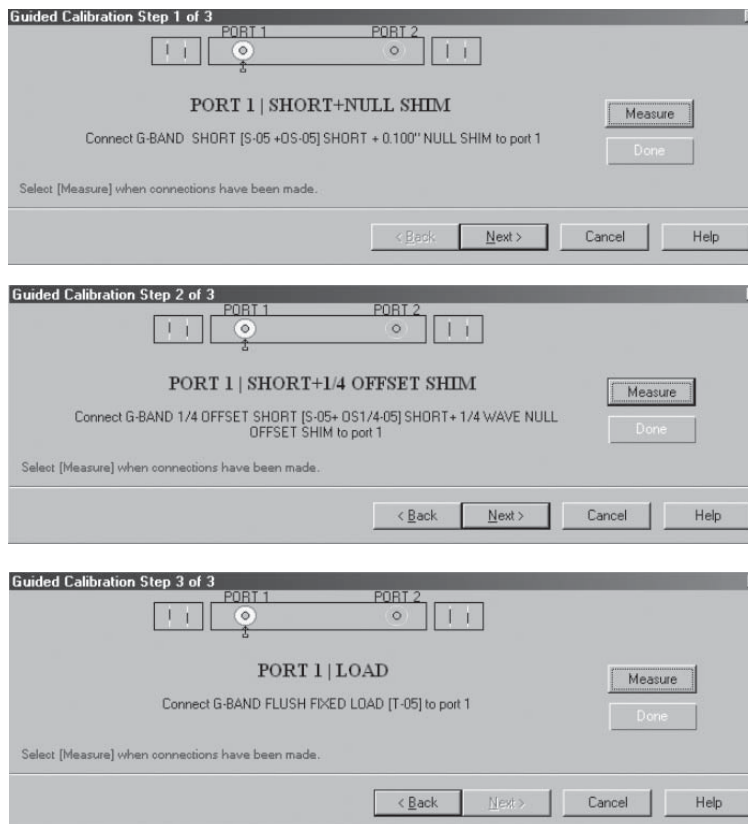

Figure 41. Steps of the 1-port calibration.

7. Congratulations! You have just completed a 1-port calibration.

Alternative:

Using an OML calibration kit to perform a 1-port SOL calibration with Offset Load would require 4 steps:

- Step 1 of 4: Port 1, Short + NULL Shim
- Step 2 of 4: Port 1, Short + ¼ Offset Shim
- Step 3 of 4: Port 1, THRU + NULL Shim, Load
- Step 4 of 4: Port 1, THRU + ¼ Offset Shim, Load

III. Unguided Calibration, Thru Response

1. Calibration > Calibration Wizard ...
2. Select **UNGUIDED Calibration**, then click **Next>** (Figure 42, top)
3. For Unguided calibration, the user must select the calibration kit because the default (or the kit last used) is often not what you want. Click on **View/Select Cal Kit** (Figure 42, middle) and then use the scroll bar to select the calibration kit of choice (Figure 42, bottom). Click **OK**.

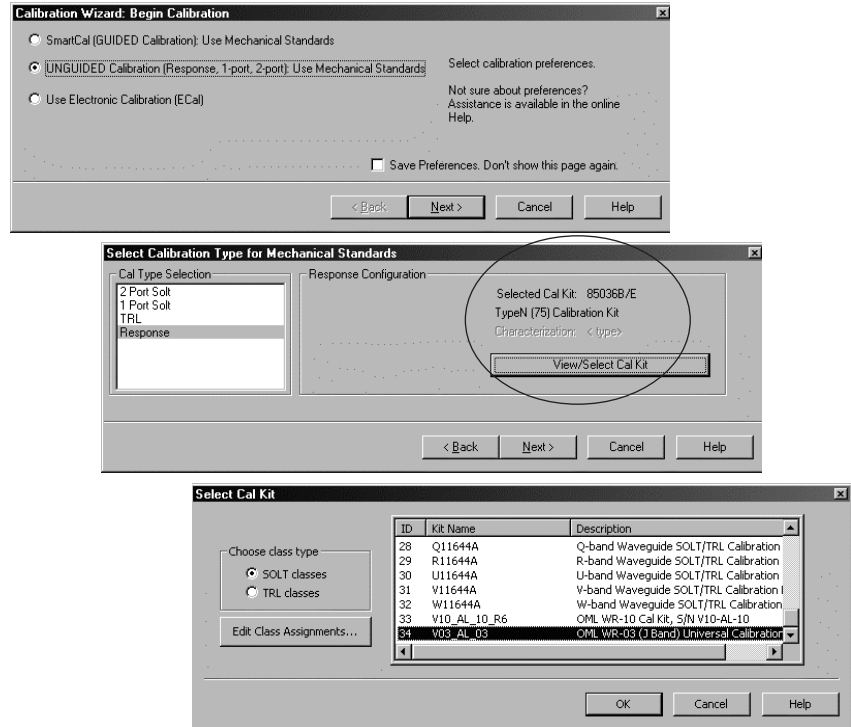

Figure 42. Select Unguided calibration, and calibration kit of choice.

4. This returns to the previous page, and the Cal Kit information has been updated (Figure 43, top). Make sure Response is highlighted on the left. (If not, click on it once.) Click Next> to start the Response calibration.

Your Response calibration selection will be different depending on your active trace. If the active trace is S11, then you will see the standard selection for Reflection Response, as those shown in Figure 43 middle. If the active trace is S21, then the standard selection are those for Transmission Response, as those shown in Figure 43 bottom.

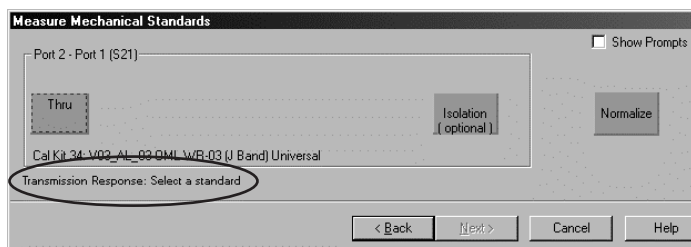
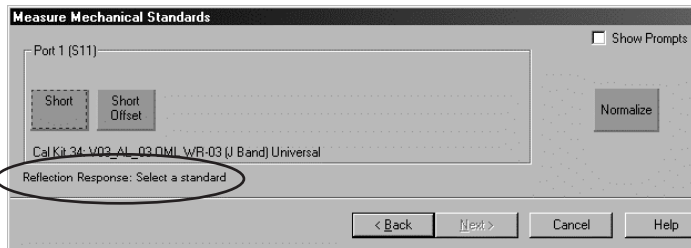
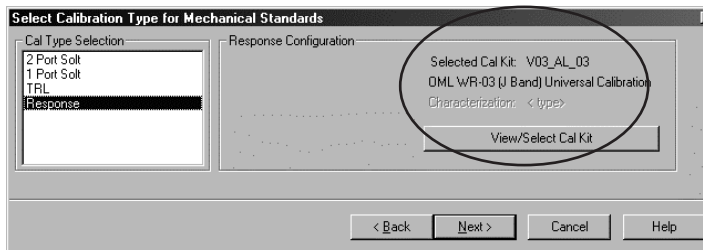

Figure 43. Response calibration and associated standard selection for Reflection Response and Transmission Response.

5. Congratulations! You have just completed a Response calibration.

Appendix C: Caring For Waveguide (WG) Interfaces

A clean surface at millimeter-wave is much more important than at lower frequencies because any debris on its surface can potentially be added to the measurement distorting the measurement results.

Caring for WG interfaces is not difficult. Dirt and dust can be removed using the following items:

- Isopropyl Alcohol 99.5%
- Lint-free cloth
- Pressurized air for dust removal

To remove dirt on the surface, simply put a few drops of the Isopropyl Alcohol on the Lint-free cloth and then gently wipe the surface.

To remove dust, simply spray the pressurized air on the surface.

Appendix D: Supplemental Data

As can be seen in Figures 17 through 20, using external synthesizers for higher frequency ranges, such as 140 to 220 GHz (WR-05) and 220 to 325 GHz (WR-03), can improve dynamic range up to 10 dB and 20 dB, respectively, as well as improving trace noise. Below, figures 44 through 46 show that the PSG series used as external synthesizers do not make any difference with or without Option UNX, ultra-low (close-in) phase noise. We chose to focus our comparison in the frequency range of 220 to 325 GHz only because if there is any noticeable difference, it would easily appear at this frequency range than at a lower one. In the comparison, either both PSG units have Option UNX, or they both do not.

In the case of trace noise, both transmission (S21) and reflection (S11) have remained very low regardless of Option UNX. They are less than ± 0.0300 dB in the worst case; above 290 GHz in the case of S21, and above 305 GHz in the case of S11.

Based on these measurement results, we are no longer including Option UNX on the PSG configurations when used as external synthesizers.

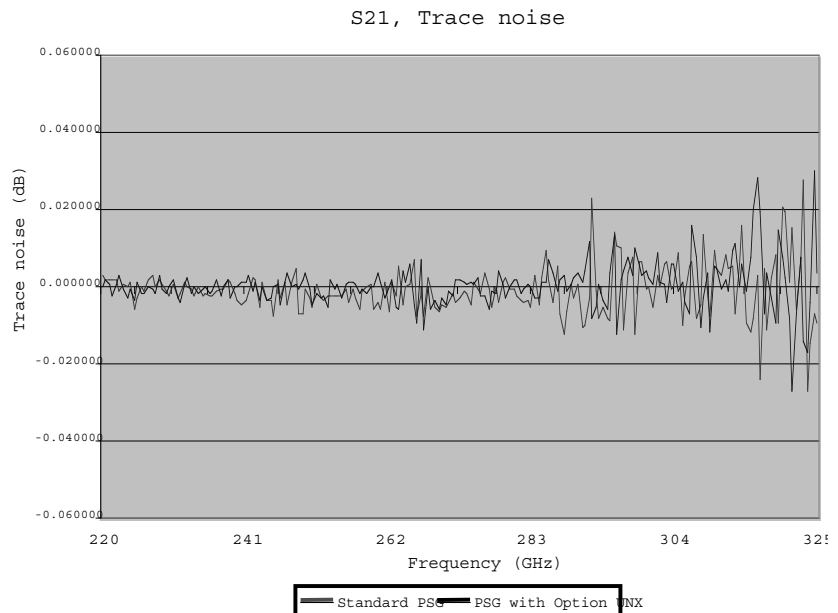

Figure 44. S21 trace noise comparison between measurements made with external synthesizers with and without Option UNX, ultra-low (close-in) phase noise.

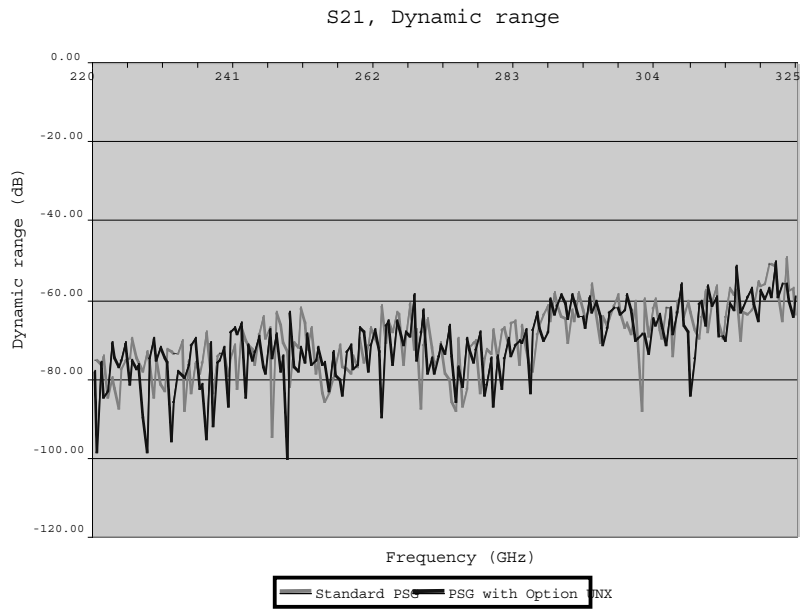

Figure 45. S21 dynamic range comparison between measurements made with external synthesizers with and without Option UNX, ultra-low (close-in) phase noise.

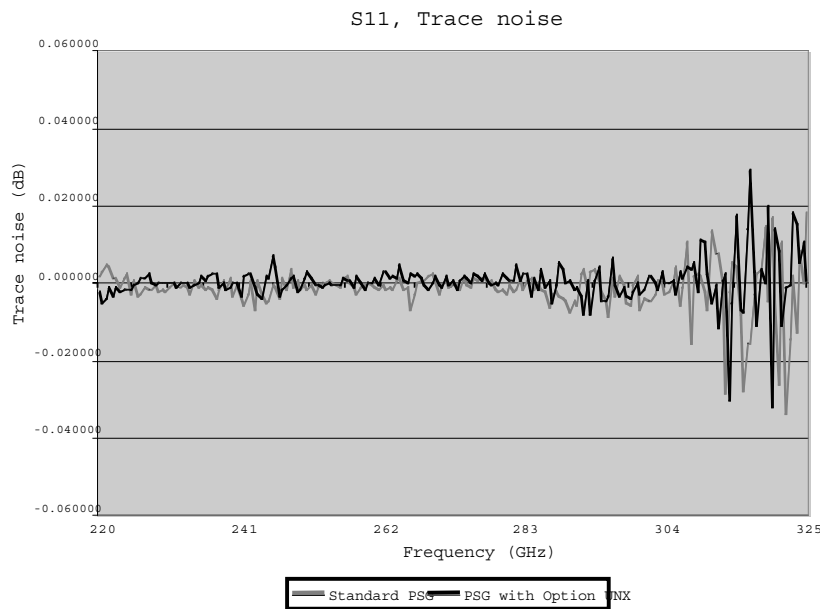

Figure 46. S11 trace noise comparison between measurements made with external synthesizers with and without Option UNX, ultra-low (close-in) phase noise.

Web Resources

For additional literature and the latest product information, visit our Web sites:

PNA Series Network Analyzers
www.agilent.com/find/pna

Antenna measurements
www.agilent.com/find/antenna

PSG Signal Generators
www.agilent.com/find/psg

Test and measurement accessories
www.agilent.com/find/accessories



Agilent Email Updates

www.agilent.com/find/emailupdates
Get the latest information on the products and applications you select.



www.lxistandard.org

LXI is the LAN-based successor to GPIB, providing faster, more efficient connectivity. Agilent is a founding member of the LXI consortium.

Agilent Channel Partners

www.agilent.com/find/channelpartners

Get the best of both worlds: Agilent's measurement expertise and product breadth, combined with channel partner convenience.

Remove all doubt

Our repair and calibration services will get your equipment back to you, performing like new, when promised. You will get full value out of your Agilent equipment throughout its lifetime. Your equipment will be serviced by Agilent-trained technicians using the latest factory calibration procedures, automated repair diagnostics and genuine parts. You will always have the utmost confidence in your measurements. For information regarding self maintenance of this product, please contact your Agilent office.

Agilent offers a wide range of additional expert test and measurement services for your equipment, including initial start-up assistance, onsite education and training, as well as design, system integration, and project management.

For more information on repair and calibration services, go to:

www.agilent.com/find/removealldoubt

www.agilent.com
www.agilent.com/find/mmwave

For more information on Agilent Technologies' products, applications or services, please contact your local Agilent office. The complete list is available at:

www.agilent.com/find/contactus

Americas

| | |
|---------------|----------------|
| Canada | (877) 894 4414 |
| Latin America | 305 269 7500 |
| United States | (800) 829 4444 |

Asia Pacific

| | |
|-----------|----------------|
| Australia | 1 800 629 485 |
| China | 800 810 0189 |
| Hong Kong | 800 938 693 |
| India | 1 800 112 929 |
| Japan | 0120 (421) 345 |
| Korea | 080 769 0800 |
| Malaysia | 1 800 888 848 |
| Singapore | 1 800 375 8100 |
| Taiwan | 0800 047 866 |
| Thailand | 1 800 226 008 |

Europe & Middle East

| | |
|----------------|-----------------------|
| Austria | 43 (0) 1 360 277 1571 |
| Belgium | 32 (0) 2 404 93 40 |
| Denmark | 45 70 13 15 15 |
| Finland | 358 (0) 10 855 2100 |
| France | 0825 010 700* |
| Germany | 49 (0) 7031 464 6333 |
| Ireland | 1890 924 204 |
| Israel | 972-3-9288-504/544 |
| Italy | 39 02 92 60 8484 |
| Netherlands | 31 (0) 20 547 2111 |
| Spain | 34 (91) 631 3300 |
| Sweden | 0200-88 22 55 |
| Switzerland | 0800 80 53 53 |
| United Kingdom | 44 (0) 118 9276201 |

Other European Countries:

www.agilent.com/find/contactus

Revised: October 1, 2009

Product specifications and descriptions in this document subject to change without notice.

© Agilent Technologies, Inc. 2009
Printed in USA, November 24, 2009
5989-4098EN



Agilent Technologies