



TRAVELING-WAVE TUBE AMPLIFIERS

I. INTRODUCTION

Early in 1954 the Hewlett-Packard Company introduced two new broadband traveling-wave tube microwave amplifiers. These amplifiers were designed to operate in the 2-4 kmc range, and have proved to be extremely important in furthering many kinds of high-frequency development work. The success of such applications together with our confidence in the traveling-wave tube amplifier's valuable broadband amplification and modulation properties have led us to further develop this field. Two new traveling-wave tube amplifiers have been developed to cover the 4-8 kmc and 7-12.4 kmc ranges. These two new amplifiers will be followed at a later date by other traveling-wave tube amplifiers covering additional frequency ranges.

The importance of these amplifiers lies in their high gain, generous power output, linear amplification characteristics, extremely versatile modulation properties, and very wide (2:1) bandwidths. These exceptional features can be used to solve many difficult problems in high-frequency work.

This paper describes some applications well suited to the traveling-wave tube amplifier's unique amplification and modulation properties. In doing so, we hope to stimulate the development of new applications for these extremely versatile instruments. The first section considers applications arising from the traveling-wave tube's broadband amplification features; the second describes applications involving its versatile modulation properties. In addition, to aid in understanding the operation of the traveling-wave tube amplifier, Appendix I presents a simplified explanation of how the traveling-wave tube works. Appendix II presents some design considerations for the special constant-amplitude sawtooth generator described under Phase Modulation. A current data sheet accompanies this paper describing the various Hewlett-Packard traveling-wave tube amplifiers.

II. AMPLIFIER APPLICATIONS

A. Broadband Amplification

A traveling-wave tube amplifier can faithfully amplify many broadband signals such as those employed in television relay, broadband microwave carrier systems, etc. In addition to this broadband feature, the traveling-wave tube amplifier has a linear amplification characteristic and relatively flat frequency response over the band.

Copyright 1955
Hewlett-Packard Company

10KY080



Since the traveling-wave tube amplifier does not require tuning, it is exceptionally easy to operate and is capable of solving many high-frequency problems in a very simple, straightforward manner. Some specific applications for the traveling-wave tube amplifier's broadband-amplification properties are:

- (1) Investigation of information handling capacity in broadband microwave communication systems.
- (2) Preamplification of low-level input signals to wide-band microwave receivers.
- (3) Amplification of low-frequency harmonics to produce frequency markers used in microwave frequency measurements.

B. Narrowband Amplification

In many narrow-band applications the traveling-wave tube amplifier's great bandwidth permits shifting the narrow band over a considerable frequency range to avoid noise, interference, etc., without changing basic amplifier circuitry. However, one strong objection to the use of a broadband amplifier for narrow-band amplification is the noise amplified over the greater bandwidth. In such cases, noise can be greatly reduced by using a narrow-band filter in the amplifier output.

C. Power Amplification

Traveling-wave tube amplifiers, such as the hp 491, can also be used as moderate-power, wide-band signal sources by amplifying the low power output typical of many klystron signal generators. Thus a signal generator-traveling wave tube amplifier combination can be used in many applications requiring generous amounts of microwave power, such as wide-range antenna measurements to plot patterns, determine efficiency, directivity, etc., or can be used as low-cost, portable means of providing moderate-power microwave signal sources for field-siting microwave installations.

D. Constant Gain or Constant Output Amplification

Many amplifier applications require a constant-gain or a constant-output level characteristic. Although the traveling-wave tube amplifier's saturated gain characteristics can be used to provide constant output power, the use of suitable feedback circuitry provides a more versatile and effective means of control. One such arrangement for obtaining a constant r-f output voltage is shown in Figure 1. In this circuit a portion of the r-f signal is coupled from the traveling-wave tube output, through a directional coupler to a detector such as a crystal rectifier. The rectified voltage is then amplified and applied to the traveling-wave tube grid or cathode. With this

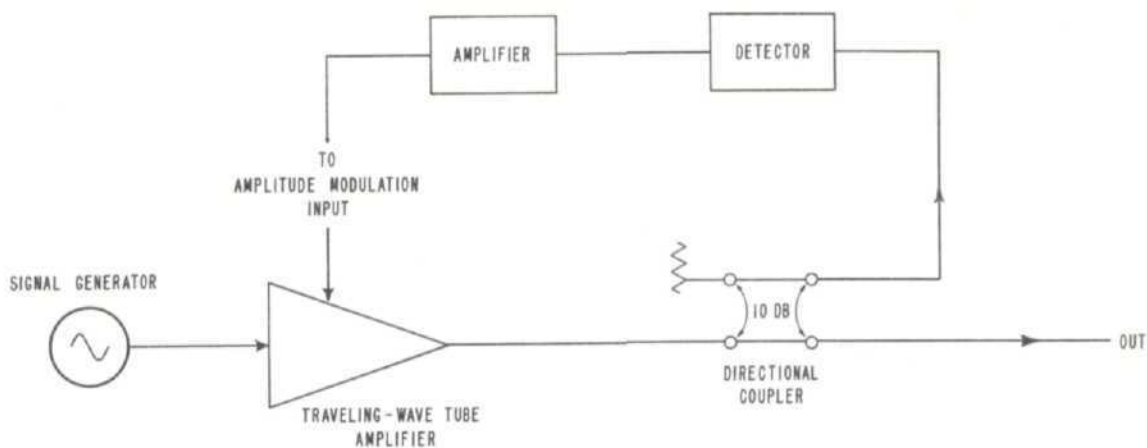

Figure 1. The traveling-wave tube amplifier used to provide a constant r-f output level.

arrangement any tendency for the output level to increase is immediately detected, amplified, and fed back to reduce the gain of the traveling-wave tube amplifier. Conversely, any reduction in output level increases the gain of the amplifier to hold the output level constant. In practice, output levels can be held within 2 db during input signal variations as great as 20 db.

E. Buffer or Isolator

The traveling-wave tube amplifier also acts as a buffer between a microwave signal source and an external load. As a buffer it isolates load reflections from the signal source and eliminates the ill affects which occur when the source is modulated directly.

III. MODULATION APPLICATIONS

A. Amplitude Modulation

The traveling-wave tube amplifier is particularly suitable for use as the power amplifier of an amplitude-modulated master-oscillator-power-amplifier system. This feature opens new fields of application since it is not possible to amplitude-modulate a reflex klystron directly. Furthermore, the traveling-wave tube amplifier's use as a power amplifier means that the r-f output from a microwave oscillator can be sine-wave, pulse or pulse train modulated without the starting delays and jitter generally present when the oscillator itself is modulated. Thus, in addition to amplification, the traveling-wave tube provides a simple system of amplitude-modulation.

Amplitude modulation is accomplished by varying the electron-beam current while a CW signal is being amplified. Beam current can be changed by varying the potential applied to one of the electrodes in the electron gun -- for example, varying the modulation grid potential. However, amplitude-modulated signals produced by varying the grid potential have attendant phase modulation. The graph in figure 2 shows that over the linear portion of the grid-voltage vs. output-voltage curve, about 10 db amplitude-modulation produces approximately 90° phase-modulation. Although this degree of phase-modulation may limit the usefulness of grid-modulation, this method can be used in applications where phase relationships are not involved in demodulation.

B. Phase Modulation

The traveling-wave tube amplifier can also be used as the amplifier of a phase- or frequency-modulated master oscillator-power amplifier system. The phase-modulation characteristic is nearly linear and permits many unique and specialized applications. Some of these applications will be discussed following a basic description of the modulation process.

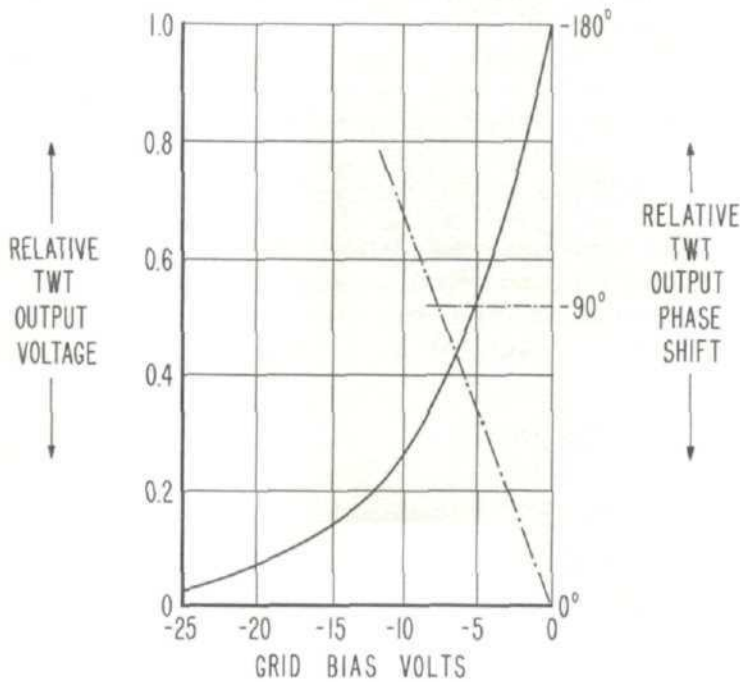

GRID MODULATION CHARACTERISTICS

Figure 2. Traveling-wave tube amplifier grid modulation characteristics.

(1) How Phase Modulation is Accomplished

Phase-modulation is accomplished by varying the electron-beam velocity while a CW signal is being amplified. Electron-beam velocity is varied by changing the potential between the cathode and the helix -- a positive voltage change will accelerate the electron bunches and advance the phase of the output signal; a negative change will slow them and retard the phase of the output signal. Thus, if the helix voltage is varied by an applied sine-wave, the output frequency will be phase-modulated at the same rate, and the phase-deviation will be directly proportional to the applied voltage.

The helix voltage can be varied directly by the desired modulating signal, however, the degree of phase-deviation produced is limited by the amount of incidental amplitude-modulation permissible in the RF output, and is limited to the small range of helix voltages that produce amplification. Beyond this limited range, amplification decreases rapidly and attenuation occurs. As a practical matter, phase deviation is limited to slightly more than 360° if the output amplitude is to be held to variations within a few db. Limited phase deviations of 360° can be obtained with total helix voltage variations of less than 50 volts.

Although limited phase-deviation is useful in some applications, unlimited phase-deviation has a much wider range of usefulness. Unlimited phase-deviation can be effectively simulated by continuously repeating the limited 360° phase-deviations. This is accomplished by modulating the traveling-wave tube helix with a sawtooth waveform to simulate a continuous variation in phase (Figure 3), and to produce r-f output frequencies that are shifted in relation to the traveling-wave tube input frequency (Figure 4).

In practical applications, a constant amplitude, linear-slope sawtooth generator is used to produce the sawtooth waveforms (See appendix II). If the sawtooth voltage amplitude is adjusted to produce a 360° phase shift, one cycle of the CW signal will be added or subtracted during each sawtooth, and the frequency shift produced in the traveling-wave tube output will be equal to the sawtooth repetition rate. Sawtooth voltages similar to those shown in Figure 4 produce an increase in the output frequency. Conversely, sawtooth voltages of the opposite slope cause a decrease in output frequency.

Under sawtooth-modulation the desired output-frequency shift (f_1 in Figure 4) occurs during the sawtooth rise time, and is proportional to the rate of rise. During the sawtooth flyback time the output-phase is shifted in the opposite direction producing an undesired frequency shift (f_2 in Figure 4). However, if the flyback time is made extremely short, this frequency is

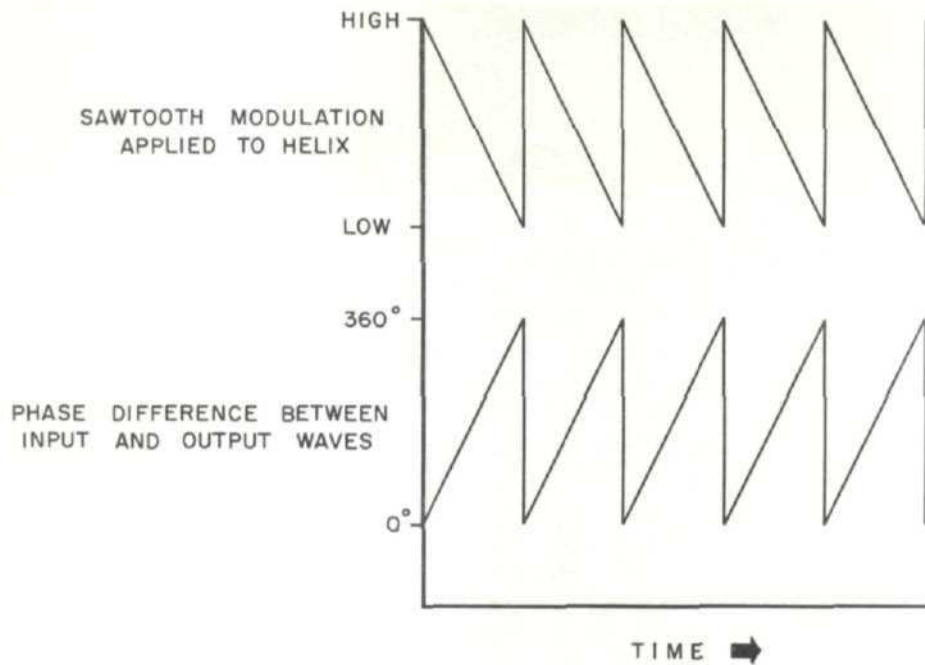

Figure 3. Phase shift in traveling-wave tube output caused by sawtooth voltage applied to helix

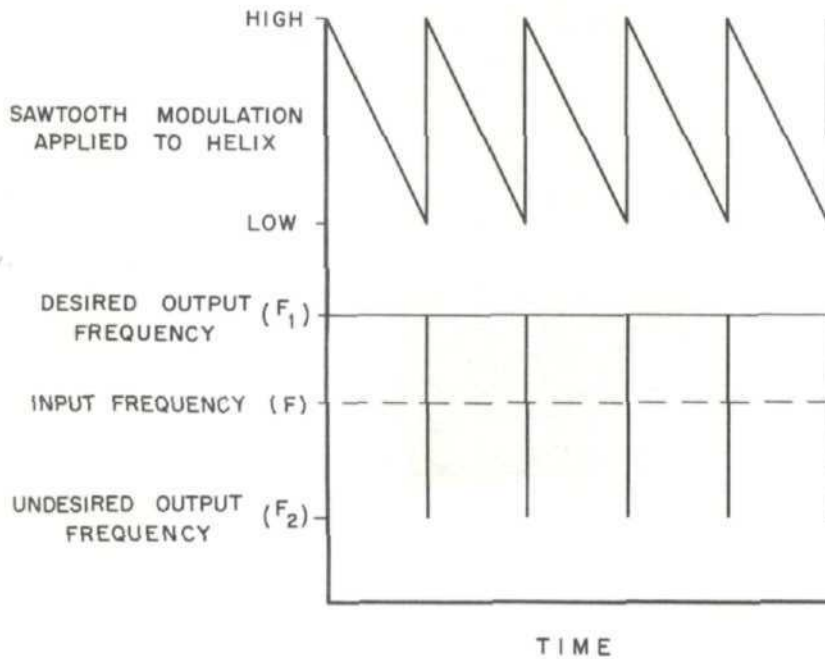

Figure 4. Frequency shift in traveling-wave tube output caused by sawtooth voltage applied to helix

far removed from the desired frequency since the frequency shift is inversely proportional to the extremely short flyback time. In addition to being far removed from the desired frequency, the power in the undesired frequency is very small since it is proportional to the ratio of flyback time to sawtooth time. In a typical case involving a desired 50 kc frequency shift, a one microsecond flyback time would produce a 1 megacycle frequency shift in the opposite direction containing only 5% of the total power in the output wave. As a practical matter, this large undesired frequency shift with its relatively small power content would be rejected by most narrow band circuits. Thus in most situations the effect of the undesired frequency-shift can be largely ignored.

In systems where the undesired frequency shift falls within the pass band of the equipment under test, an arrangement can be devised to cut off the traveling-wave tube beam current during the flyback time. This arrangement applies a negative pulse to the electron gun control grid during the flyback time and eliminates the undesired frequency shift although it produces some small transients and leaves small areas of no signal where the flybacks occur.

(2) Linear (Homodyne) Detection

The frequency shift produced by sawtooth modulating the traveling-wave tube helix can be used in a linear (homodyne) detector to greatly extend the sensitivity and dynamic range of microwave measurements. Dynamic ranges approaching 100 db may be obtained using this system of detection, as compared to the limited 50 db range for a square-law detector. Practical applications include the measurement of extremely high VSWR's, accurate calibration of attenuators over wide amplitude ranges, frequency shifting of microwave radio relay channels for retransmission, production of mixer frequencies for radar and other microwave receivers, etc.

A typical linear detector system suitable for calibrating microwave attenuators is illustrated in Figure 5. The signal generator supplies a strong signal (f) to a crystal mixer and to a traveling-wave tube amplifier. The traveling-wave tube amplifier is sawtooth modulated to produce a shifted output frequency ($f + f_1$) which is applied to the attenuator under calibration. The weak output signal from the attenuator is then combined with the strong reference signal in the mixer to produce a beat-frequency (f_1). This beat-frequency is amplified by a tuned amplifier and is indicated on a VSWR indicator, such as the Gp Model 415B.

(3) Doppler Frequency Shift Simulation

Frequency-shifts produced by sawtooth modulation also make the traveling-wave tube amplifier uniquely suited for doppler

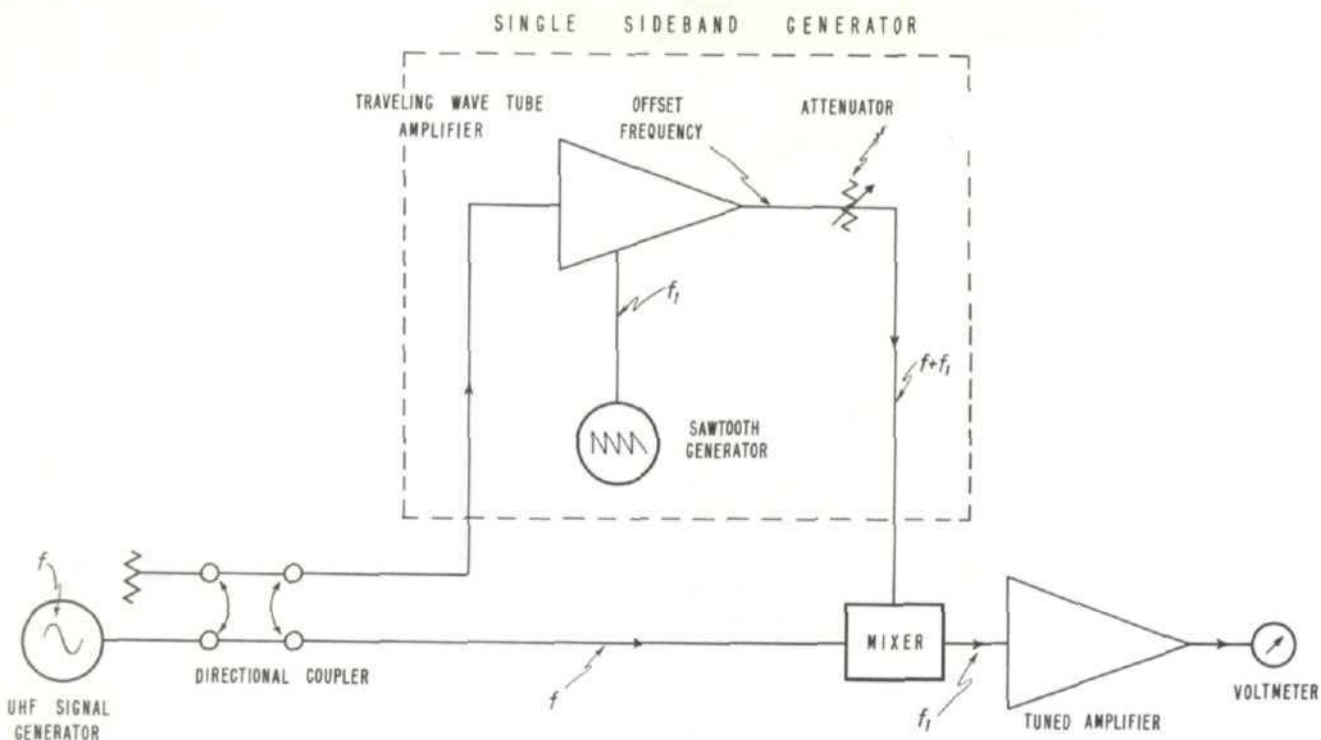

Figure 5. Linear (homodyne) detection system for microwave measurements.

simulation. In this role the traveling-wave tube amplifier provides an exceptionally simple and flexible method of electronically checking radar, navigational and other instrumentation systems. Prior to the introduction of the traveling-wave tube amplifier, several complicated methods were used to simulate Doppler frequency-shift. Some of these methods involved critically tuned narrow-band crystals, others were mechanical and cumbersome.

Doppler frequency-shift is used in many CW radar systems to determine the velocity at which a target and source are approaching or receding from each other. The basic concept is that the frequency of the returning CW signal will be shifted in direct proportion to the relative velocity of the target and source. This relationship may be written:

$$\text{Frequency shift (cps)} = \text{Velocity (mph)} \times \text{Frequency (kmc)} \times 3$$

A typical traveling-wave tube doppler-shift simulator is shown in Figure 6. In this arrangement, the helix in the traveling-wave tube amplifier is modulated by a sawtooth waveform which shifts the r-f output frequency. The amount of frequency-shift is proportional to the sawtooth repetition-rate and is readily adjusted and calibrated. The output attenuator is adjusted so that the power from the traveling-wave tube amplifier is less than the input power level. Note that in this arrangement return power can be attenuated to correspond to weak target reflections thus providing an easy way to test radar system sensitivity.

(4) Wide Range Frequency Modulation (unlimited phase deviation)

Although sawtooth helix modulation has many interesting applications, most microwave communications systems require the transmission of much more complex information. For these applications a sawtooth waveform produced by the special generator described in Appendix II can be slope-modulated by any type waveform before being applied to the traveling-wave tube helix. In this manner, complex signals can be used to frequency modulate the traveling-wave tube's output and the center CW frequency

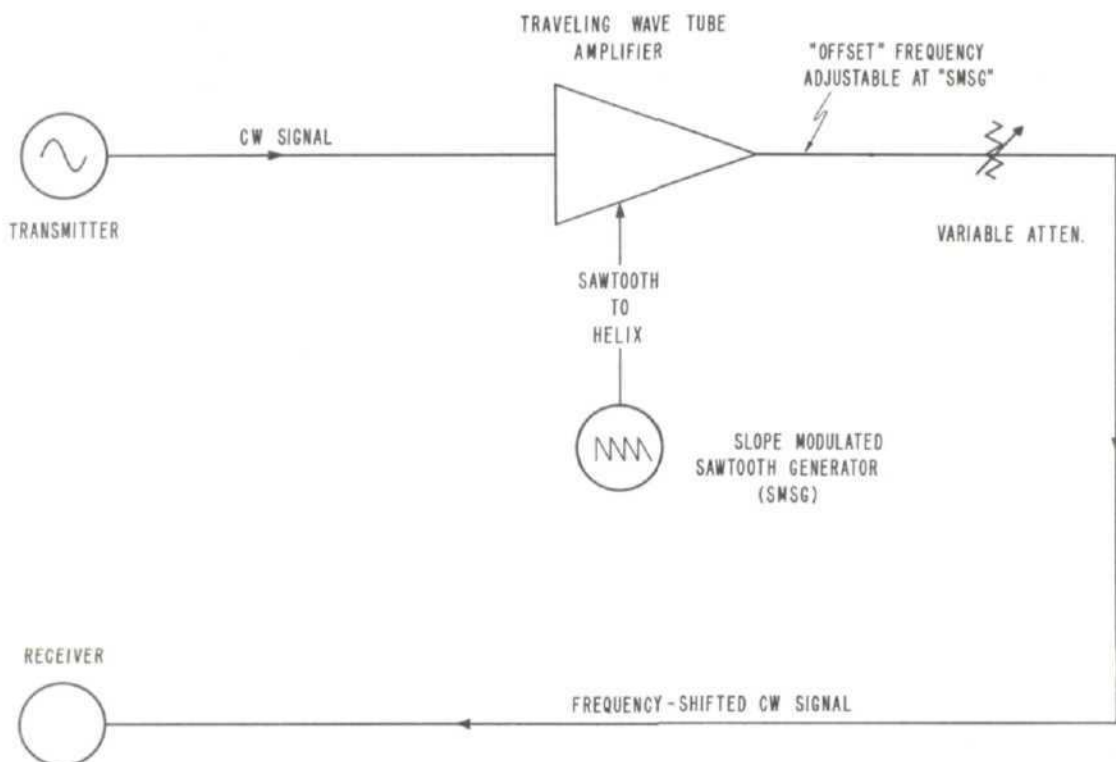

Figure 6. Simplified diagram of a traveling-wave tube amplifier Doppler frequency-shift simulator.

will be fixed by the sawtooth repetition rate. Unlimited phase-deviation can be approximated, however, in no case does the phase shift due to a single sawtooth exceed 360° and the amplification properties of the traveling-wave tube amplifier will not be adversely affected regardless of the magnitude of the apparent phase deviation when the sawtooth wave is modulated.

This method of transmitting complex information is valuable in many broadband communication applications. Of special interest is the use of this process to check CW radar and navigational systems which indicate both target velocity and range information using a single CW transmitted signal. The use of Doppler frequency-shift simulation to check velocity measuring equipment has already been discussed. However, to check range-measuring equipment, the shifted signal produced by the sawtooth-modulated traveling-wave tube amplifier must be frequency modulated to simulate the delayed signal received by the radar receiver. Frequency-modulated signals identical to those encountered in CW radar systems of this type can thus be simulated and a simple method provided for electronically checking and calibrating velocity and range functions in the laboratory as well as in the field.

Figure 7 illustrates a laboratory set-up which demonstrates the simulation of these frequency-shifted, frequency-modulated signals. In this arrangement, an oscilloscope replaces the radar receiver so that the variations in the simulated reflected radar signals can be shown visually.

October 1955

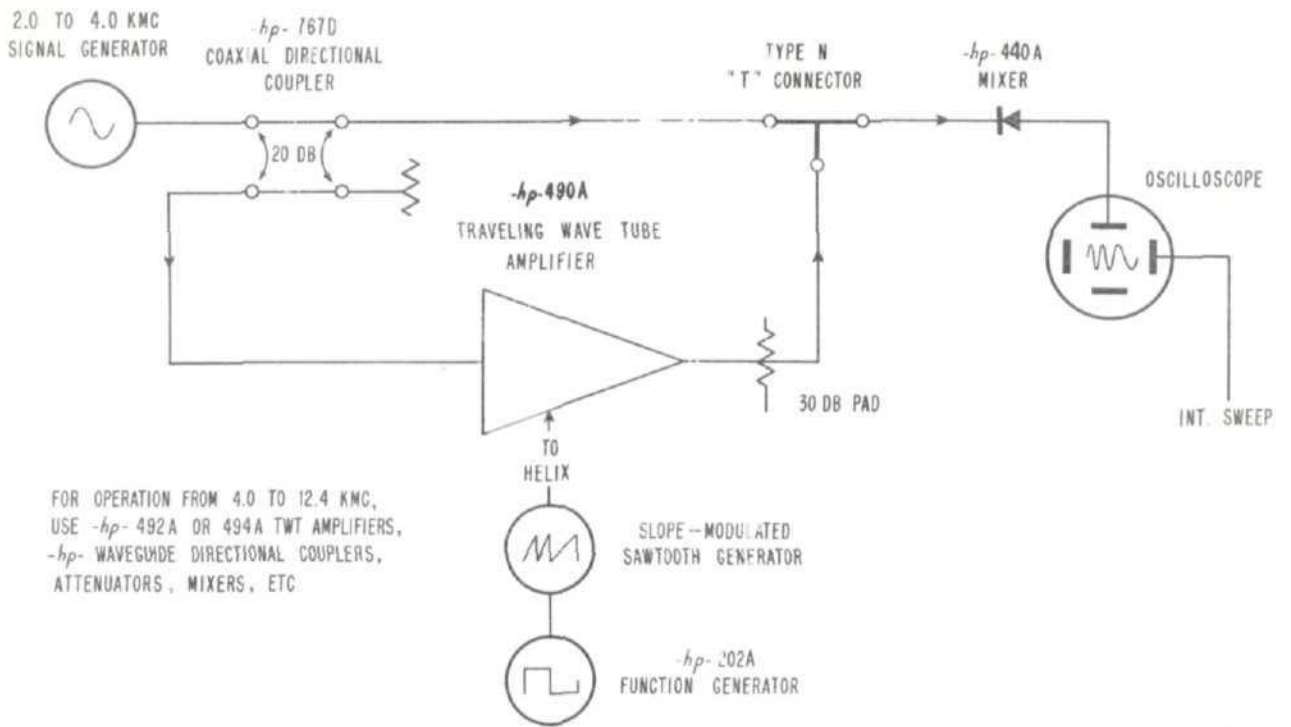
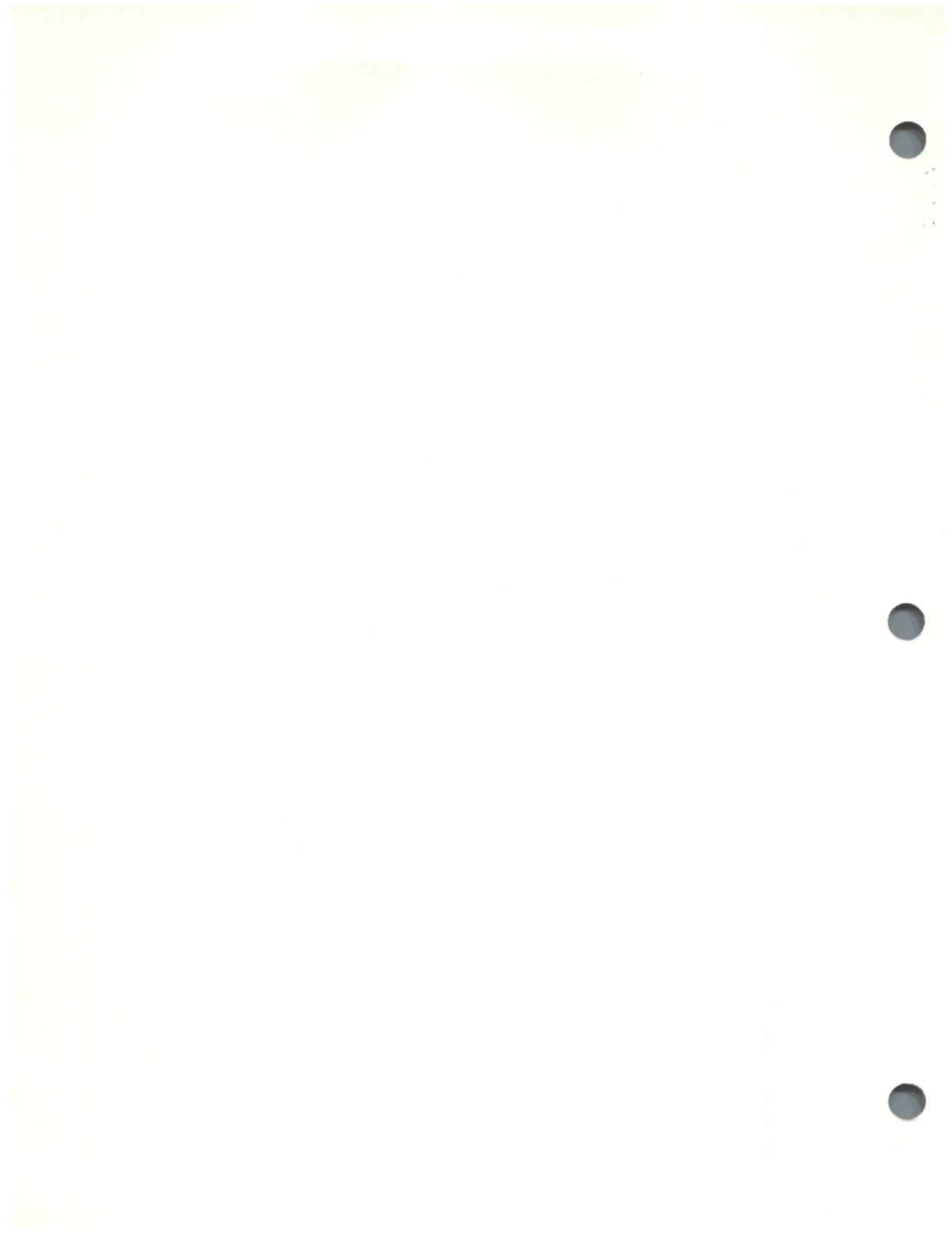

Figure 7. Laboratory set-up to demonstrate the simulation of frequency-shifted and frequency-modulated CW radar signals



APPENDIX I

THE TRAVELING-WAVE TUBE AMPLIFIER AND HOW IT WORKS

The basic traveling-wave tube amplifier consists of an electron gun which projects a focused electron beam through a helically-wound coil to a collector electrode, shown in Figure 1. The focused electrons are held in a pin-like beam through the center of the helix by a powerful magnetic field around the full length of the tube.

A CW signal coupled into the gun-end of the helix travels around the turns of the helix and thus has its lineal velocity reduced by an amount equal to the ratio of the length of wire in the helix to the length of the helix itself. The electron beam velocity, determined by the potential difference between the cathode and the helix, is adjusted so that the electron beam travels a little faster than the CW signal. The electric field of the CW signal on the helix interacts with the electric field created by the electron beam and increases the amplitude of the signal on the helix, thus producing the desired amplification.

Figure 2 is a diagram showing the principal elements of a typical traveling-wave tube in the upper portion, and the important steps in the amplification process in the lower portion. The steps should be followed by referring to the numbered captions.

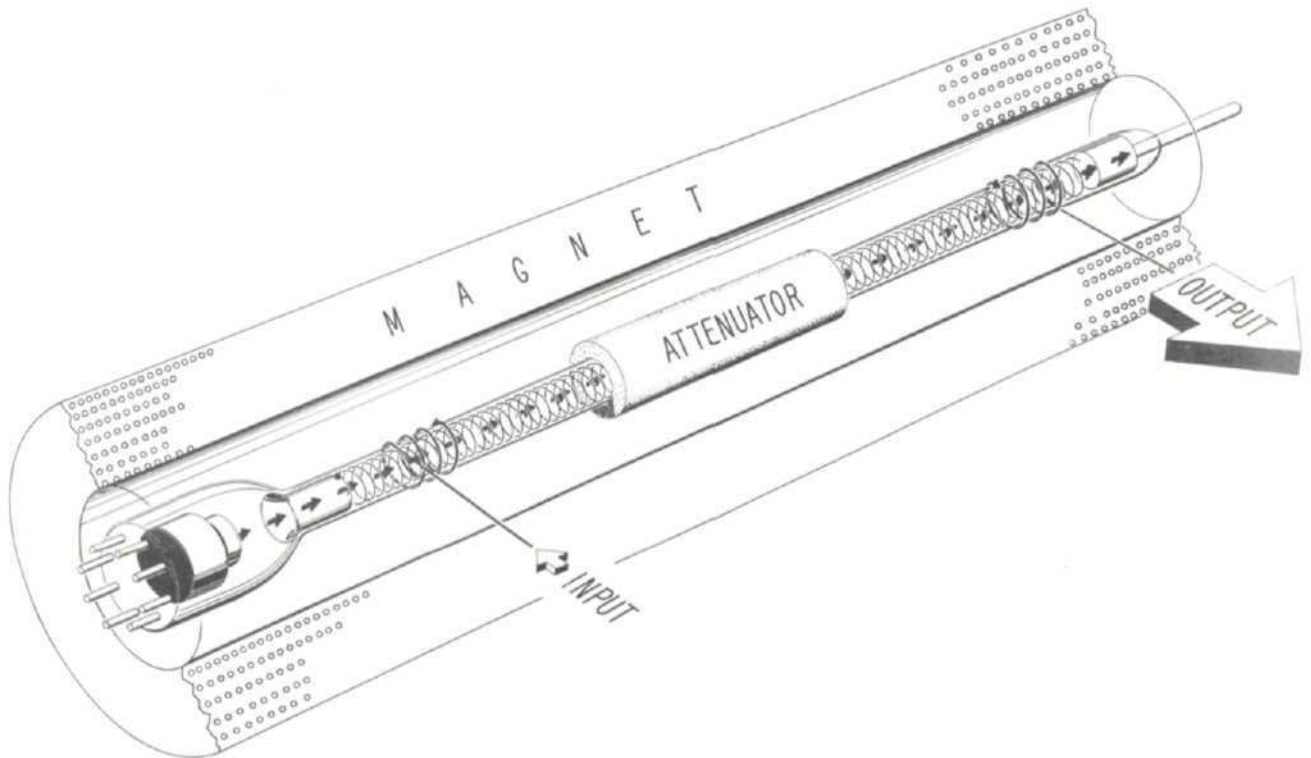
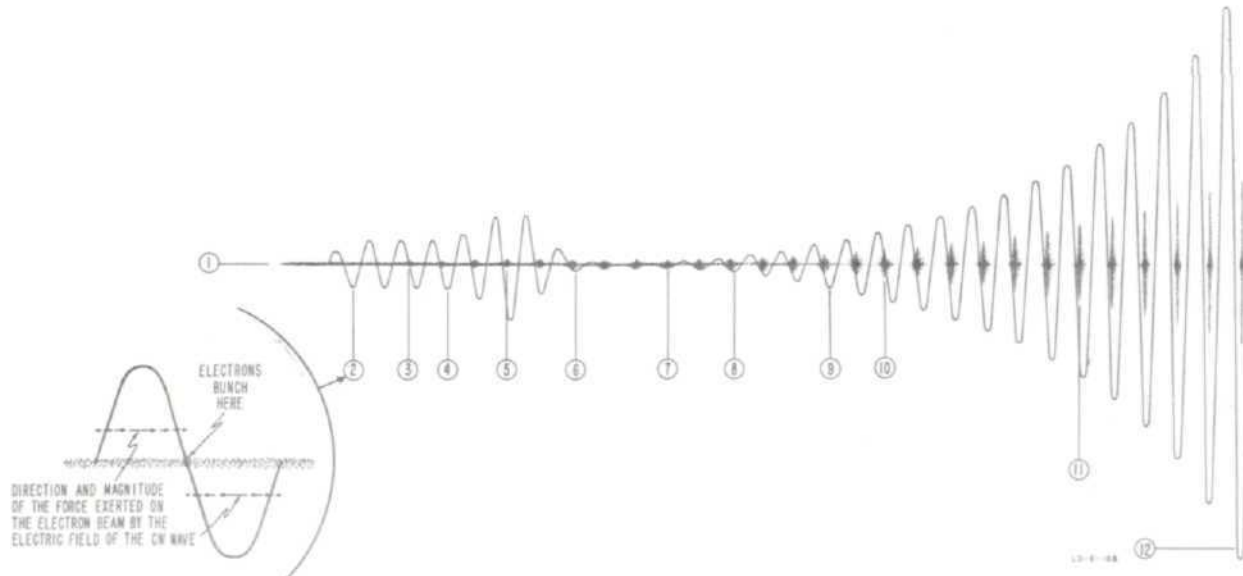
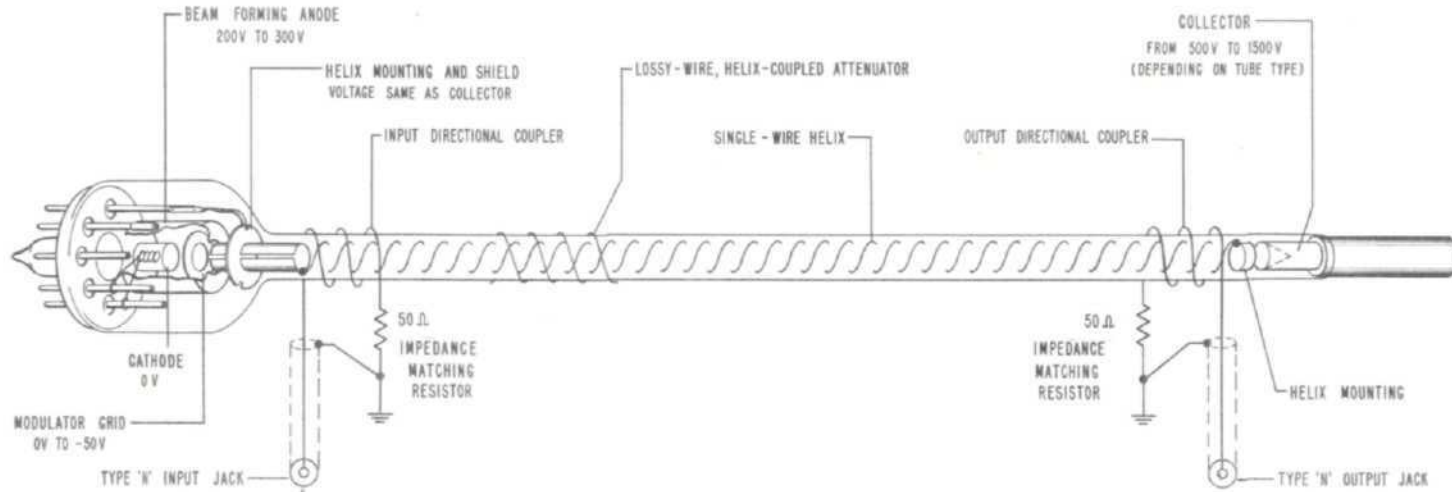

Figure 1. Cutaway view, showing important elements of a traveling-wave tube amplifier.

CAPTIONS TO ACCOMPANY FIGURE 2.

1. Electron beam directed through center of helix.
2. CW signal coupled into helix. Arrows in detail show direction and magnitude of force exerted on the electron beam by the CW signal.
3. Electron bunching caused by the electric field of the CW signal (See Detail).
4. Amplification of signal on helix begins as the field formed by the electron bunches interacts with the electric field of the CW signal. The newly formed electron bunch adds a small amount of voltage to the CW signal on the helix. The slightly amplified CW signal then produces a denser electron bunch which in turn adds a still greater voltage to the CW signal, and so on.
5. Amplification increases as the greater velocity of the electron beam pulls the electron bunches more nearly in phase with the electric field of the CW signal. The additive effect of the two fields exactly in phase produces greatest resultant amplification.
6. Attenuators placed near the center of the helix reduce all the waves traveling along the helix to nearly zero. This prevents undesired waves, such as waves reflected from mismatched loads, from returning to the tube input and causing oscillation.
7. Electron bunches travel through attenuator unaffected.
8. Electron bunches emerging from attenuator induce a new CW signal on helix. New CW signal is the same frequency as the original CW signal applied.
9. Field of newly induced CW signal interacts with bunched electrons to begin the amplification process over again.
10. For a short distance the velocity of the electron bunches is reduced slightly due to the large amount of energy absorbed by the formation of the new CW signal.
11. Amplification increases as the greater velocity of the electron beam pulls the electron bunches more nearly in phase with the electric field of the CW signal.
12. At point of desired amplification the amplified CW signal is coupled out of the helix. Note that the "amplified" CW signal is a new signal whose energy is wholly supplied by the bunched electron beam.

THE TRAVELING-WAVE TUBE AND HOW IT WORKS



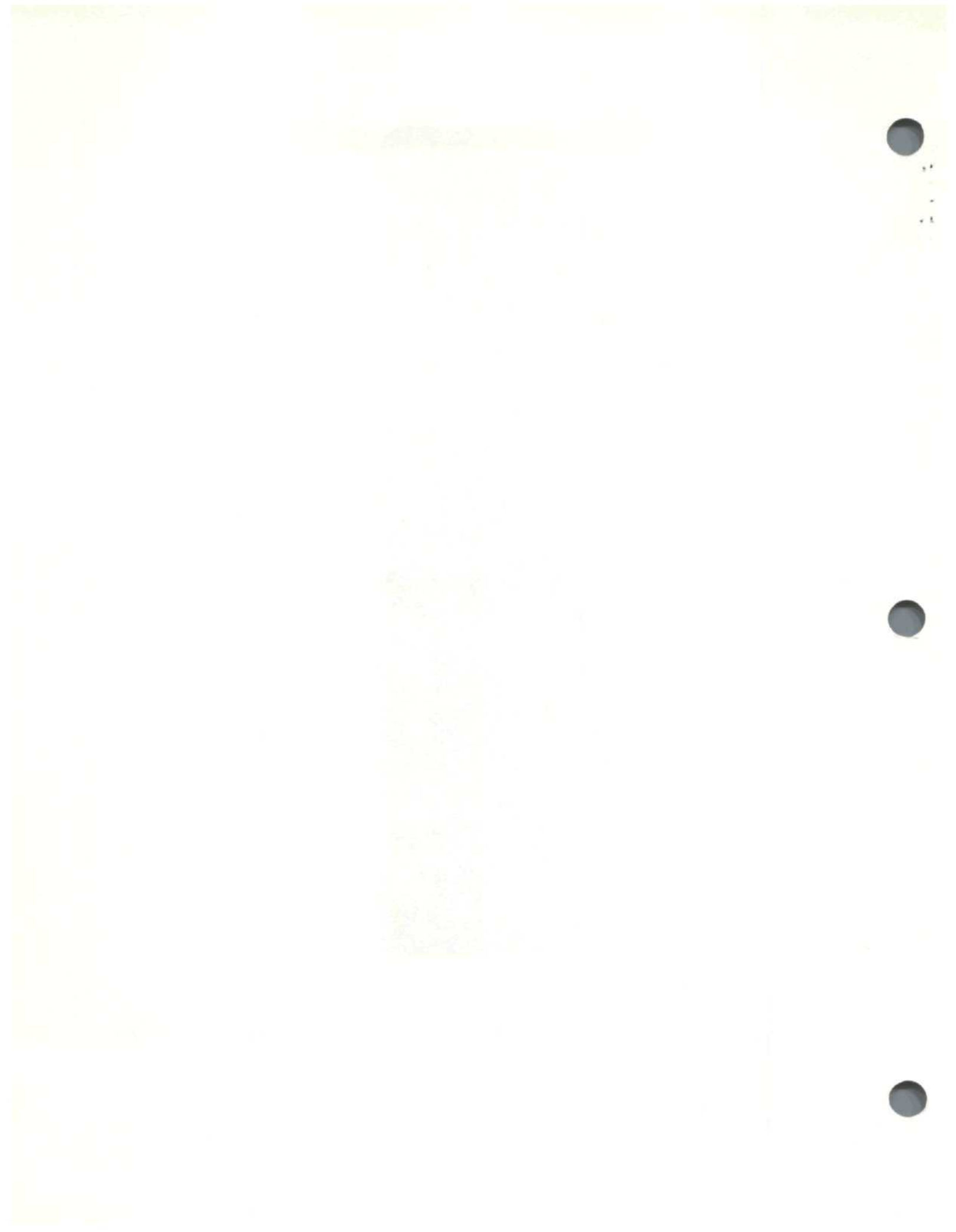

APPENDIX II

NOTES ON A CONSTANT-AMPLITUDE, LINEAR SAWTOOTH GENERATOR

To merely shift the phase or frequency of the r-f output from a traveling-wave tube amplifier, a simple sawtooth like those used in oscilloscope sweep circuits can be applied to the traveling-wave tube helix. However, if the r-f output signal is to be stable, and contain a minimum of spurious signals (splatter, etc.) the sawtooth waveform applied to the helix must be constant in amplitude, must be linear, and must not contain noise or ripple. In addition, the sawtooth amplitude and the sawtooth repetition rate must be completely independent and separately adjustable, the repetition rate preferably over a wide range. If the r-f output from the traveling-wave tube amplifier is to be frequency-modulated, it must also be possible to modulate the slope or repetition rate of the sawtooth wave without affecting the sawtooth amplitude.

A sawtooth generator having these characteristics is shown in simplified form in Figure 1. This generator consists of an adjustable, regulated power supply, a charging capacitor, a blocking oscillator to charge the capacitor, a pentode tube to discharge the capacitor, and a cathode follower to isolate the generator from the output.

The dotted line in Figure 1 indicates the capacitor charging circuit, the solid line the discharge circuit. The operation of the generator is described as follows:

When power is applied to the generator, the grid-bias on the blocking oscillator tube is zero and the oscillator goes through one cycle of operation. During the cycle, the tube conducts heavily and charges the capacitor to the B+ voltage. The oscillation cycle is very short and produces a rapid sawtooth flyback. The charge on the capacitor biases the blocking oscillator tube beyond cutoff and prevents further operation until the charge is removed.

The instant the blocking oscillator is biased to cutoff, the capacitor begins to discharge through the pentode tube at a rate determined by the pentode's grid bias. The capacitor is discharged at a linear rate due to the constant current characteristics of the pentode and thus produces a very linear slope on the output sawtooth.

As the capacitor is discharged, the grid bias on the blocking oscillator returns towards zero, and at a low value the tube conducts sufficiently to put the oscillator through another cycle of operation, thus again recharging the capacitor, etc.

The amplitude of the output sawtooth waveform is adjusted by changing the regulated B+ to vary the charge placed on the capacitor. The repetition rate is adjusted by changing the pentode grid-bias to control the rate at which the capacitor is discharged. Modulating signals are applied to the control grid of the pentode modifying the nominal grid-bias level thus changing the capacitor's discharge rate and in turn, the sawtooth slope and repetition rate.

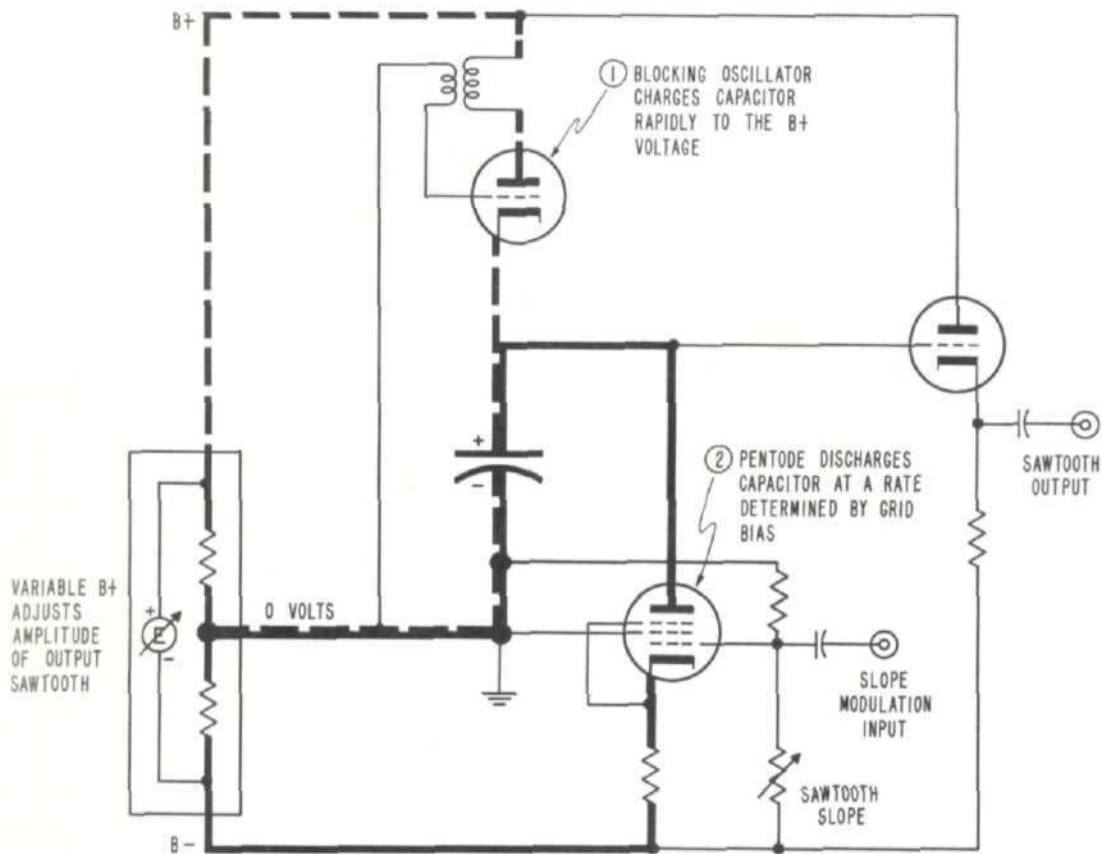

Figure 1. Simplified schematic diagram of a Sawtooth Generator having independent amplitude and slope functions.