

HCPL-3700

Ring Detection with the HCPL-3700 Optocoupler



Application Note 1024

Introduction

The field of telecommunications has reached the point where the efficient control of voice channels is essential. People in business are communicating to a larger extent over telephone, and they are requiring lower cost, easy, and quick access to phone lines. These requirements, coupled with the evolution of the modem, automatic phone answering equipment, and communication between computers over public lines, have resulted in the introduction of electronic control and private automatic branch exchange (PABX) systems. There must, however, be isolation between the sensitive, microprocessor-based, control circuitry and the higher voltage, transient-prone transmission line. Optocouplers, or optical isolators, are effective, reliable, and inexpensive devices for achieving this protection and isolation. An area where optocouplers can be used to great advantage is in the ring detection portion of the control circuitry, and that will be the emphasis of this application note.

The Nature of the Ring Signal

Ring detection is the first operation necessary in completing the connection between the central office and the individual telephone. Figure 1 illustrates a simplified version of this connection.

When a request to connect a particular line comes to the central office, the ring signal is transmitted on the tip and ring of the requested line until an off-hook condition is detected through the presence of a DC loop current. The nature of this ring signal is addressed in the Federal Communications Commission's Part 68, in section 312 (On-hook Impedance Limitations). Essentially, the ringing signal is a sinusoidal wave of frequency ranging from 15.3 to 68.0 Hz. The amplitude of the ring signal, which is superimposed upon a DC voltage between tip and ring of -48 V, can vary from 40 to 150 VRMS. The AC impedance must be greater than 1600 Ω . Due to the fact that the central exchange detects an off-hook condition by the presence of a DC current, the DC impedance presented by the ring detection circuitry must be very high. Part 68 states that "the DC resistance between tip and ring conductors, and between each of the tip and ring conductors and earth ground shall be greater than 10 M Ω for DC voltages up to and including 100 V."

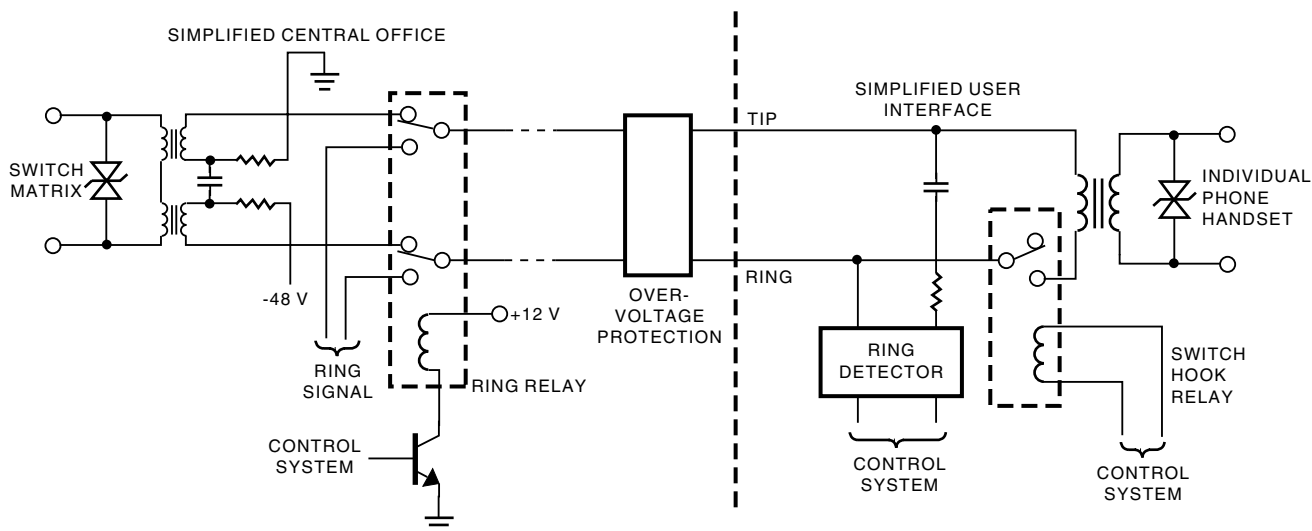

Figure 1. Simplified Central Office-to-User Interface

Regulations are slightly different in Europe, with voltage amplitudes varying from 30 VRMS to 100 VRMS at a nominal frequency of 25 Hz.

Therefore, the ring signal is obviously not logic compatible and cannot be interfaced directly to electronic circuitry. Furthermore, lightning-induced transients, in the form of a very high voltage, underdamped sinusoid, as well as other environmentally induced transients such as dial pulses from other extensions on the same line, must also be protected against. The ring detector must output a logic compatible signal in the presence of ring signal with amplitude anywhere within the U.S. or European regulations, and also discriminate between this signal and any transient that might be present on the transmission line.

The HCPL-3700: Easy Threshold Detection and Filtering

The HCPL-3700 offers a complete, optimal solution to the ring detect problem with a minimal amount of external components needed. This optocoupler features a Zener diode full-wave bridge rectifier at the input, followed by a hysteresis buffer and constant current source to drive the LED. The LED is turned on or off at prescribed voltage and current thresholds. These thresholds can be adjusted by the insertion of a series impedance. The output stage of the optocoupler is a photodetector and a split-Darlington amplifier circuit. A schematic diagram of the HCPL-3700 is shown in Figure 2.

To turn the LED on, which results in an output low state, the positive threshold must be exceeded. The correct external impedance must be used to ensure that this switching occurs at the desired point, according to the following equation:

$$Z_{Ext} = (V_{+(Min)} - V_{TH(MAX)+}) / I_{TH(MAX)+} \quad (1)$$

where $V_{TH(MAX)+}$ and $I_{TH(MAX)+}$ are given in the data sheet and $V_{+(MIN)}$ is the desired switching point. (If detection of a ring signal of 40 VRMS minimum is desired, this value would be $40 \times \sqrt{2} = 56.6$ V.)

To meet the requirement of presenting a very high DC impedance to the central office, it is advantageous to AC couple the ring signal. This is accomplished by using a series capacitor. This capacitor, in conjunction with series resistance, creates the impedance required to set the threshold of the HCPL-3700 and to meet the AC impedance requirement. The impedance is then approximated as shown in Equation (2).

$$Z_{Ext} = \left(R_{Ext}^2 + \left[\frac{1}{2 \pi f_{Ring} C} \right]^2 \right) 0.5 \quad (2)$$

If we choose a capacitor of 2.2 mF, and assume a minimum ringing frequency of 15 Hz and a minimum amplitude of 40 VRMS, then we can calculate a value for the external resistance using equations (1) and (2).

The external resistance is then split up equally between the tip and the ring lines in order to provide a balanced line termination and transient suppression on both lines. Figure 3 shows the equivalent circuit using the results from equation (3).

$$R_{Ext} = \left(\left[(V_{+(Min)} - V_{TH(MAX)+}) / I_{TH(MAX)+} \right]^2 - (1/2 \pi f_{Ring} C)^2 \right) 0.5 \quad (3)$$

$$R_{Ext} = 15700 \Omega$$

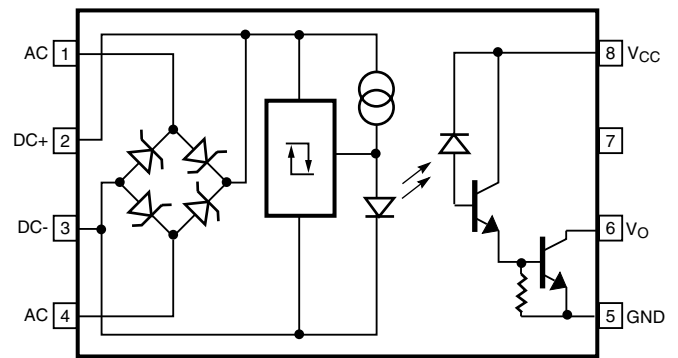

Figure 2. Schematic Diagram of HCPL-3700

The power dissipation required of the resistors must also be taken into account. The Zener diode bridge at the input of the HCPL-3700 clamps the voltage across the AC inputs at approximately 7 V. The amount of power that then must be dissipated by each of the two external resistors is shown in Equation (4):

$$P = [(V_{Ring(Max)} - 7)/2]^2 / R \quad (4)$$

where R is $R_{EXT}/2$. If the peak amplitude of the ring signal is 150 VRMS, then each resistor must dissipate 1.4 watts. A 2-watt resistor will provide extra protection. At the level of current present in the circuit, there is no danger of exceeding the maximum current rating of the optocoupler.

The output signal is essentially a square wave of frequency twice that of the input signal. To obtain a signal that is at logic low throughout the duration of the ring signal some type of filtering is required. This filtering can either be done at the input or the output of the HCPL-3700. Figure 4 shows the waveforms that would be obtained with input or output filtering.

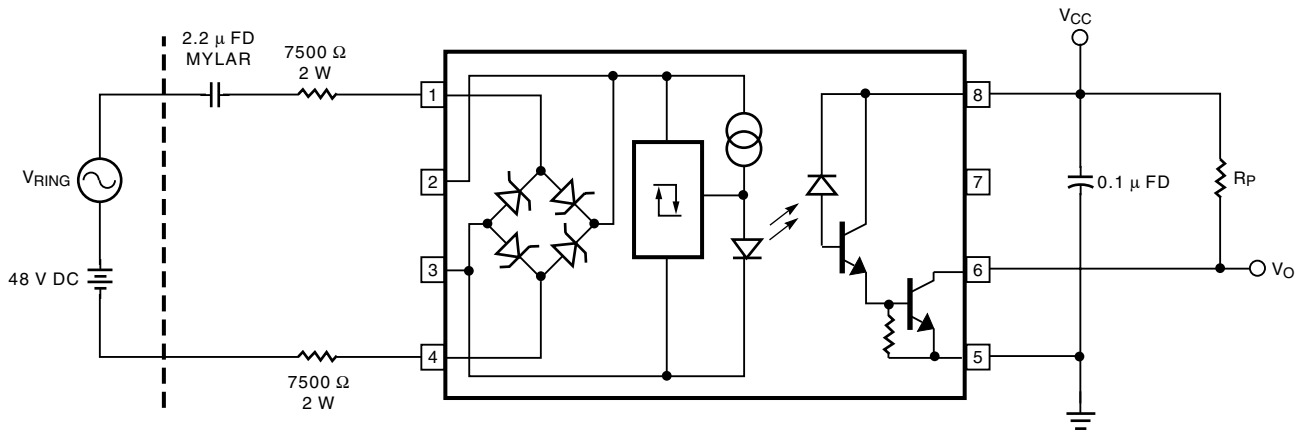

Figure 3. Equivalent Circuit for Detection of 40 VRMS Signal

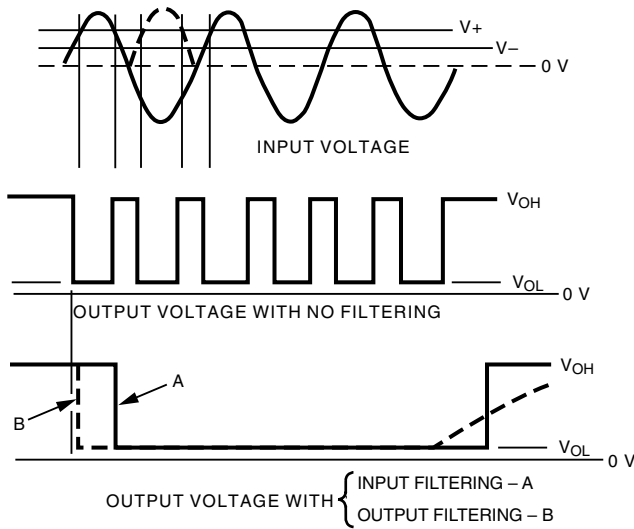

Figure 4. Waveforms for Input and Output Filtering

If filtering is done on the output, the result will be a signal that begins to respond very quickly to a change in the ring signal but has very slow transitions. A comparator with hysteresis would then be needed at the output to digitize the signal. If filtering were done at the input, the output would not respond as quickly to a change in the ring signal but the edges would be much quicker. A comparator would not be needed. Since a slight delay in detection of the ring signal is generally tolerable, the input filtering technique is preferred. There is the added benefit of filtering, which follows from the fact that ring detection is slightly delayed. This benefit is that quick-edged transients with amplitudes in the range of the ring signal will not affect the output signal. The filter will eliminate them.

Input filtering is accomplished through the insertion of a capacitor across the DC inputs of the optocoupler (pins 2 and 3). Because the frequency of the ring signal can go down as low as 15 Hz, this capacitor should be 33 μ F. The voltage rating should be greater than 7 V, the clamping voltage of the Zener diode bridge rectifier. The introduction of this capacitor results in about a 30% reduction in the amplitude of the voltage detected by the optocoupler. This means that in order to maintain the desired effective threshold of operation, the external impedance must be lowered. Equation (1) given previously now becomes:

$$Z_{Ext} = [(V_{+(Min)} (0.7) - V_{TH(Max)+}) / I_{TH(Max)+}] \quad (5)$$

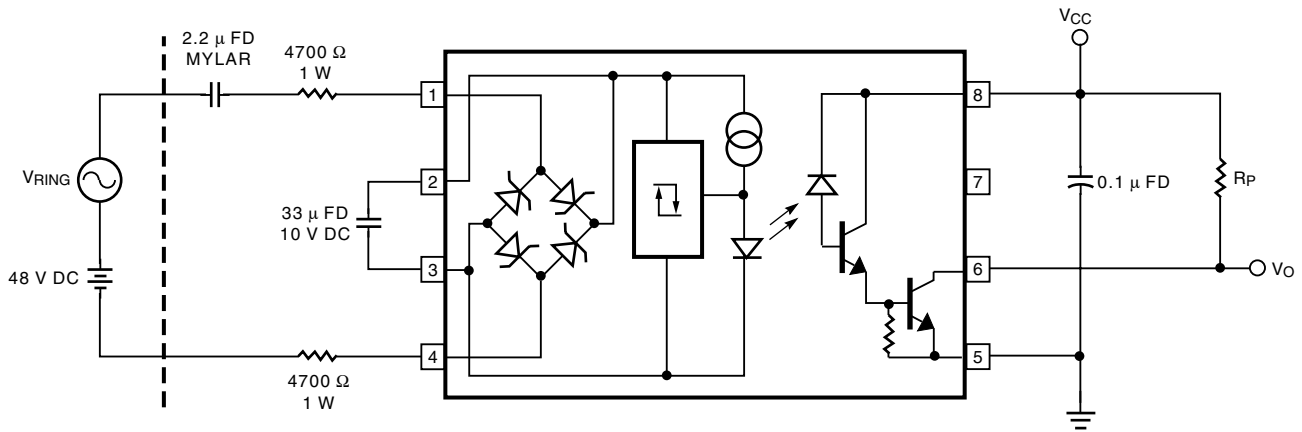

Figure a5. Equivalent Circuit with Input Filtering

Then, relating equations (2) and (5) we get the following equation which is similar to equation (3):

$$R_{Ext} = \left(\left[(V_{+(Min)} (0.7) - V_{TH(Max)}) / I_{TH(Max)} \right]^2 - (1/2 \pi f_{Ring} C)^2 \right) 0.5 \quad (6)$$

Using the same values used previously, we obtain a value for R_{EXT} of 9845 Ω. The final equivalent circuit with filtering is then shown in Figure 5.

The power dissipation required of the resistors is reduced somewhat, to the point where 1 W resistors could prove sufficient.

The Avago Technologies HCPL-3700 vs. Other Ring Detection Techniques

The HCPL-3700 optocoupler is a power-to-logic optocoupler which is very suitable for interfaces like ring detection where high voltage signals are monitored by sensitive electronics. It requires the least amount of external circuitry, and contains internal circuitry that allows for the most easily controllable switching point and higher reliability. Figure 6 illustrates another optocoupler design alternative which has “back-to-back” LED’s that transmit light to a single photodetector.

This type of optocoupler design has several disadvantages compared to the HCPL-3700. It is evident from the diagram of this optocoupler that input filtering is not possible. Input filtering with the HCPL-3700 is only possible because of the DC input, which allows for a capacitor to be added to integrate the already rectified signal. There is no way to integrate the AC signal after it is rectified at the input of the “back-to-back” optocoupler alternative. Therefore, in order to present a “clean,” digital signal to the following logic circuitry, output filtering must be done. This output filtering must include not only a capacitor but a comparator with hysteresis. Also, in looking at the

data sheet the minimum guaranteed On-State RMS Input Current far exceeds the maximum guaranteed Off-State RMS Input Current. There is not a well defined threshold, which further amplifies the need for a comparator.

Another consideration, which affects reliability of the optocoupler and therefore reliability of the system, is the amount of forward current that the LED is subject to. Degradation in the light output of the LED due to high current levels reduces switching stability by raising the “effective” threshold over time. Each LED in the “back-to-back” optocoupler design experiences the full excursion of the half-wave rectified current signal. This means that, in order to ensure detection of a ring signal of the minimum amplitude specified by FCC Part 68, the circuit would have to be designed in such a way that the maximum current level experienced by the LEDs could be stressful and could lead to accelerated degradation. With the HCPL-3700, threshold detection is performed prior to the LED by the buffer (with hysteresis), and the LED is driven by a switched current source at low current levels. Degradation is therefore much lower. More information on LED degradation can be found in the Avago Technologies Application Note 1002, “Consideration of CTR Variations in Optically Coupled Isolator Designs.”

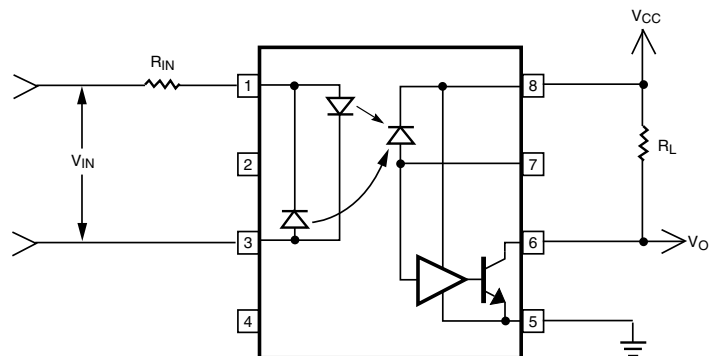

Figure 6. “Back-to-Back” Optocoupler

There also exist integrated circuit packages specifically designed for ring detection applications. This family of ring detectors does not employ optical coupling and is less immune to transients than the HCPL-3700. An application report on this ring detector states that "when used in series with the proper resistor and capacitor, these devices will withstand 1500 V/200 μ s transients." This translates to 7.5 V/ μ s which, when compared to the HCPL-3700 values of -600 V/ μ s for Common Mode Transient Immunity at Logic Low Output and 4000 V/ μ s for CMTI at Logic High Output, is extremely low. To obtain an isolated ring detection circuit with this product, the application report recommends a single phototransistor optocoupler at the output. For the straightforward ring detection application, the HCPL-3700 is preferable for ease of design, number of external components required, isolation capabilities, and reliability.

Summary

More and more aspects of the telecommunications industry are being automated, meaning that sensitive electronic devices are being interfaced with higher voltage, electrically-noisy circuitry. Ring detection is one area where this interface occurs. The sensitivity and expense of electronic equipment requires that this interface have high isolation capabilities, high performance capabilities, and a degree of versatility. Optical isolation with high performance optocouplers provides this.

For an integrated ring detection solution incorporating ease of design, a lower component count, and better predictability and reliability, the HCPL-3700 is optimal. The HCPL-3700 optocoupler contains a full-wave Zener diode bridge rectifier which, when combined with the correct input series impedance, provides a controllable, low-level current to an LED when a ring signal is present. With proper input filtering, consisting of a simple capacitor across the DC input, the output will be a digital, logic-compatible signal. A comparator is not required for interface to logic gates or microprocessors.

For product information and a complete list of distributors, please go to our web site: www.avagotech.com