Auto-Insertion of Option 002 Tape and Reel LED Lamps

Application Brief 74

Introduction

Hewlett-Packard Option 002 tape and reel LED lamps have straight leads on standard 2.54 mm (0.100 inch) center spacing. These lamps may be auto-inserted into printed circuit boards with most radial auto-insertion equipment. However, it is important to have the proper plated through hole size and spacing in the printed circuit board to assure high insertion yields.

This application brief details specific information on the printed circuit board plated through hole size, spacing and tolerances necessary to assure high insertion yields of Option 002 LED lamps with 0.46 mm (0.018 inch) square leads.

Background

The problem with auto-inserting Option 002 straight lead LED lamps shows up at the cut and clinch operation. With the Option 002 LED lamps, the mechanical stress of the cut and clinch operation is transmitted directly up the leads into the lamp package. This is in contrast to the Option 001 LED lamps that have formed leads with 5

mm (0.197 inch) spacing. The formed leads of the Option 001 lamps absorb the mechanical stress of the cut and clinch operation. Thus the stress is not transmitted to the lamp package.

The most common failure mode observed in an Option 002 LED lamp, caused by the mechanical stress of the cut and clinch operation, is a fractured lamp package, see Figure 1. A fracture splits a lamp in two between the anode and cathode leads resulting in catastrophic failure.

Auto-Insertion Tests

Tests were performed with T-1 LED lamps on a Fuji radial auto-insertion machine to determine the PC board plated through hole size and spacing that will assure high insertion yields. Figure 2 represents the auto-insertion data. For hole sizes less than 0.76 mm (0.030 inch) diameter, the unsuccessful insertions were missed insertions, bent leads or leads not in holes, due to the plated through holes being too small in size, as illustrated in Figure 1. For holes larger than 0.86 mm (0.034 inch) diameter, the unsuccessful

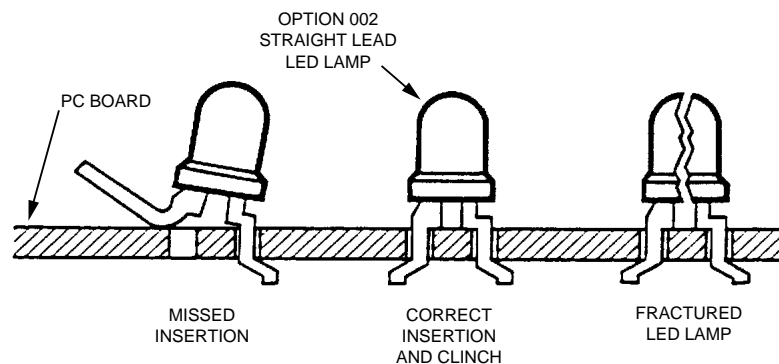

Figure 1. Correct LED Lamp Insertion Compared to Missed Insertion and Fractured LED Lamp.

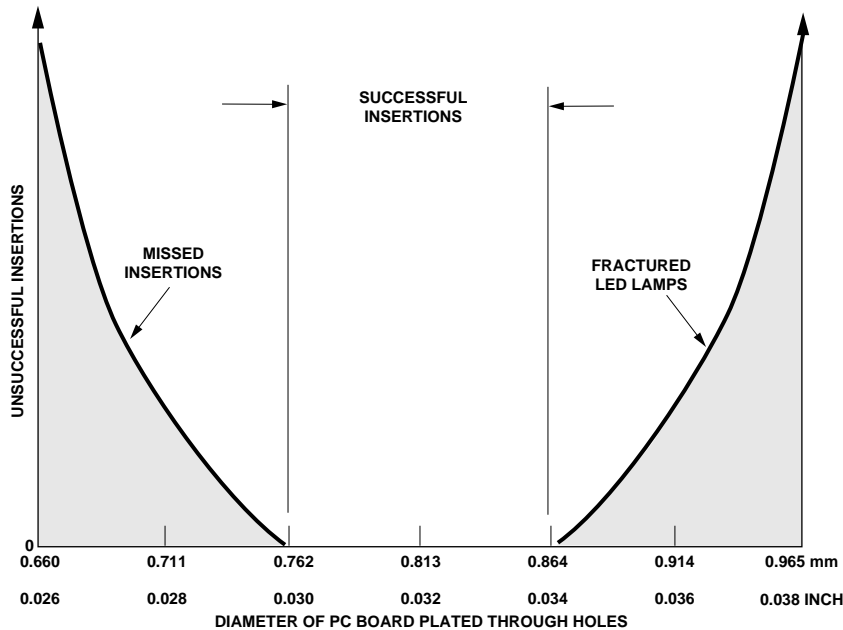
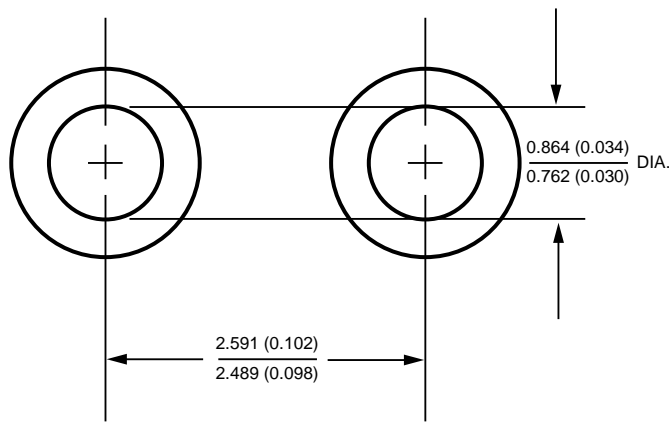

Figure 2. Successful and Unsuccessful Auto-Insertions vs. Diameter of Plated Through Holes.



ALL DIMENSIONS IN MILLIMETERS AND (INCHES)

Figure 3. PC Board Plated Through Hole Finished Size and Spacing to Assure Successful Auto-Insertion of Option 002 Straight Lead LED Lamps with 0.46 mm (0.018 in) Square Leads.

insertions were fractured LED lamp packages. For hole sizes between 0.76 mm (0.030 inch) and 0.86 mm (0.034 inch) diameter all insertion attempts were successful.

Recommended Hole Size and Spacing

Figure 3 shows the recommended plated through hole finished size and spacing dimensions for high auto-insertion yields. This recommendation is valid for use with all Option 002 straight lead tape and reel LED lamps with 0.46 mm (0.018 inch) square leads.

Other Application Notes

The following Hewlett-Packard application notes provide additional information on the auto-insertion and soldering of LED lamps.

AN 1021. *Utilizing LED Lamps Packaged on Tape and Reel*
AN 1027. *Soldering LED Components*

Acknowledgement

Hewlett-Packard expresses its appreciation to the Tektronix Corporation for running the insertion tests and providing the information contained within this application note.

For technical assistance or the location of your nearest Hewlett-Packard sales office, distributor or representative call:

Americas/Canada: 1-800-235-0312 or (408) 654-8675

Far East/Australasia: (65) 290-6305

Japan: (81 3) 3331-6111

Europe: Call your local HP sales office listed in your telephone directory. Ask for a Components representative.

Data Subject to Change

Copyright © 1995 Hewlett-Packard Co.

Obsoletes 5954-8402

Printed in U.S.A. 5964-3924E (12/95)