

Making Stimulus/Response Measurements

Using the Agilent N9322C Basic Spectrum Analyzer and Tracking Generator

The tracking generator provides a cost-effective way for spectrum analyzer users to expand their testing to cover more component-level characterization.



Introduction to Tracking Generators

A tracking generator is a signal source whose RF output follows the tuning of the spectrum analyzer. The tracking generator output signal is generated by mixing the signals from two or more oscillators. A simplified block diagram is shown in Figure 1.

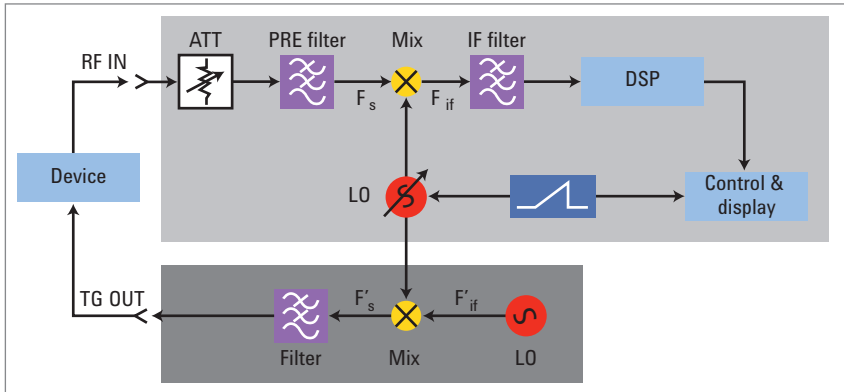

Figure 1. Block diagram of tracking generator

The tracking generator uses the Swept LO from the spectrum analyzer and mixes that LO signal with a stable, fixed oscillator. If we tune the oscillator in the tracking generator (F'_{if}), to the center frequency of the IF filter in the spectrum analyzer (F_{if}), and use the difference mixing product, then the output frequency of the tracking generator (F'_s) will equal the input frequency of the spectrum analyzer (F_s). The spans of the spectrum analyzer and tracking generator are matched and synchronous and therefore precise tracking is achieved.

Benefits of Using a Tracking Generator

1. It stretches your instrument budget — One instrument provides dual-purpose measurements.

In addition to measuring signal amplitude characteristics such as carrier power, sidebands, and harmonics, a spectrum analyzer with a tracking generator can also make scalar network analysis with high dynamic range, such as the insertion loss, pass/stop band of a component, or the gain of an amplifier. For example, adding a tracking generator to your N9322C BSA provides single-channel scalar network analysis in addition to the analyzer's spectrum analysis capabilities.

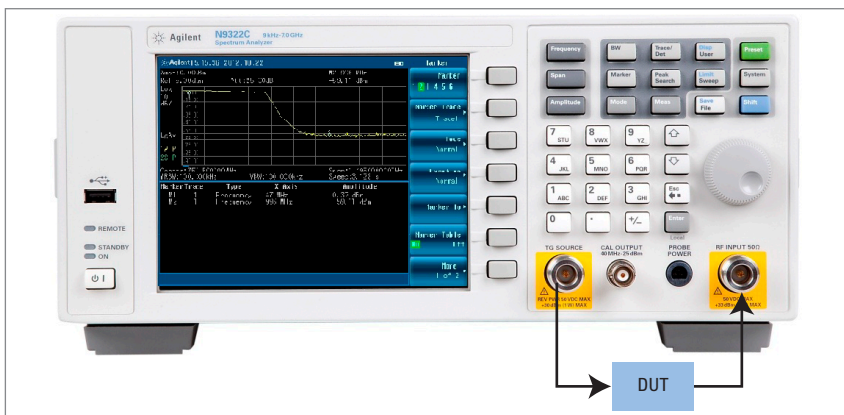

Figure 2. Using N9322C and its tracking generator for scalar network analysis

2. It is effective for scalar transmission measurements —The tracking generator output and the RF input of the spectrum analyzer are well synchronized.

The precise tracking between the tracking generator and the analyzer establishes a well-synchronized stimulus/response measurement system. It is able to cover scalar transmission measurements such as gain, frequency response, insertion loss, and flatness on components and subsystems.

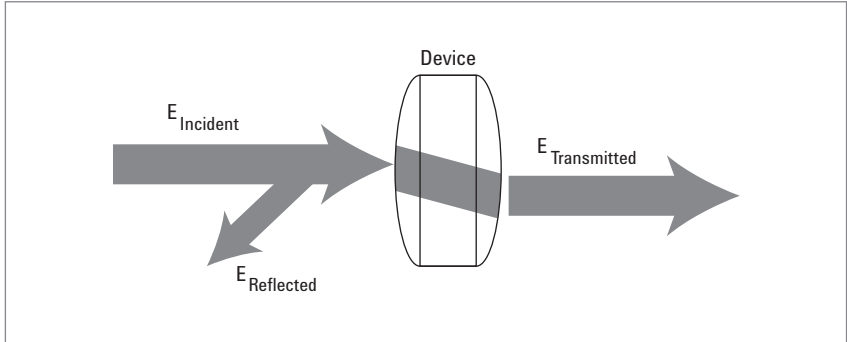

Figure 3. Transmission measurement

Differences between Network Analyzers and Spectrum Analyzers

Network analyzer	Spectrum analyzer
Measures components, devices, circuits, sub-assemblies	Measures signal amplitude characteristics
Contains source and receiver	Can demodulate and measure complex signals
Displays ratioed amplitude and phase (by frequency or power sweeps)	Contains receivers only
Offers advanced error correction	Measures scalar component (no phase information) with tracking generator or external sources

Introduction to the N9322C BSA and its Tracking Generator

The Agilent N9322C BSA is a 7 GHz general purpose spectrum analyzer. It is expandable to cover scalar transmission measurement by adding a tracking generator (Option TG7). Option TG7 gives you the ability to make accurate scalar transmission measurements, such as gain and insertion loss of a DUT.

N9322C Option TG7 Overview

- Frequency
 - Range: 5 MHz to 7 GHz
 - Resolution: 1 Hz
 - Resolution bandwidth (RBW): 3 kHz to 3 MHz
- Output power
 - Range: -20 to 0 dBm
 - Resolution: 1 dB
- Measurement dynamic range
 - Max. output power – DANL with 3 kHz RBW



Figure 4. Transmission measurement setup

Making a Transmission Measurement with the Agilent N9322C BSA

3-Step Guide to Make an accurate Transmission Measurement

1. Set up the spectrum analyzer's control settings (frequency, RBW, sweep time, input attenuation, etc.) with the DUT connected.
2. Establish a 0 dB reference by removing the DUT and measuring the incident signal level. Turn on the normalization function to subtract the incident power from the tracking generator.
3. Make the transmission measurement by re-inserting the device into the transmission measurement path.

DUT properties in the following example:

- Center frequency: 902.5 MHz
- 3 dB bandwidth: 25 MHz
- Insertion loss: < 0.8 dB
- VSWR: < 1.5
- Rejection: > 30 dBc at 880 MHz; > 30 dBc at 925 MHz

In the following demonstration procedure, text in [] indicates the hardkey and { } indicates the softkey on the N9322C spectrum analyzer.

Step 1.

Enter the tracking generator mode and set up the N9322C control parameters

1. Press [Mode] > {Tracking Generator}, and turn on the {Amplitude}, with -20 dBm output as the default power.
2. Press [Frequency] and set the center frequency to 902.5 MHz.
3. Press [Span] and set the span to 55 MHz (10 MHz wider than the 45 MHz bandwidth of the filter provides a better view on the analyzer's screen).

At this point, the N9322C's default attenuation is -20 dBm, and auto RBW setting is 300 kHz with DANL at about -66 dBm. Therefore the dynamic range of the tracking generator mode is about 46 dB. It is able to cover the measurement requirement for a 30 dBc rejection filter.

In order to achieve the most accurate and repeatable measurement result, we need to improve the dynamic range of the tracking generator measurement mode. Decreasing the attenuation and RBW are the commonly used methods.

4. Press [Amplitude] > {Attenuation} and set the input attenuation to 10 dB.
5. Press [BW] and manually decrease the RBW to 100 kHz.

You will see the measurement result as shown in Figure 5.

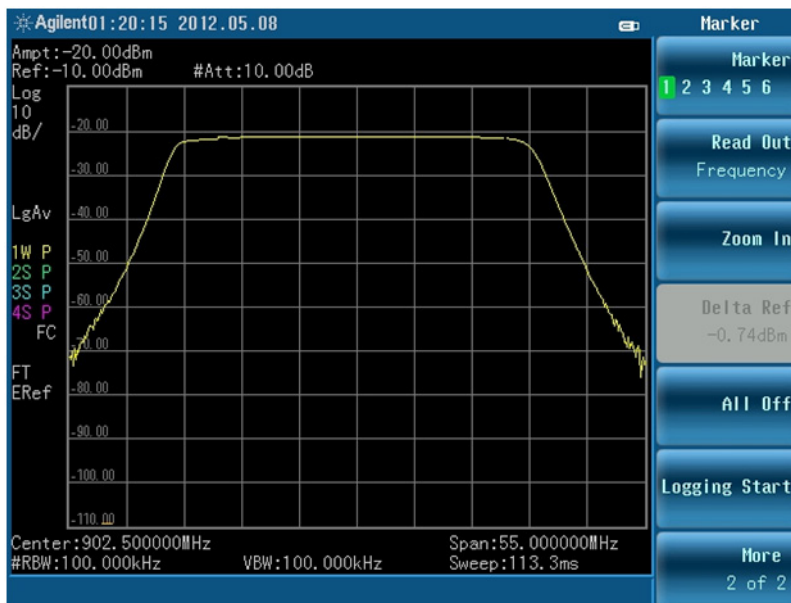

Figure 5. N9322C setups overview

Step 2.

Before we can determine the transmission loss or gain of the DUT, a “normalization” procedure is required, which will establish a 0 dB reference trace stored in the spectrum analyzer and will be used for normalizing the measured data. Refer to figure 6.

- Remove the filter from the TG output and the RF input ports
- Press [MEAS] > {Normalize}. The N9322C provides instructions for the normalization procedure
- Directly connect the tracking generator output to the spectrum analyzer input with the same test cables. If necessary, use a thru adapter, such as the Agilent N9311X-546, to connect the test cables. Notice that the frequency’s response may not be perfectly flat since its showing the response of the cables as well as the flatness of both the tracking generator and the spectrum analyzer
- Press [Enter] > {Store Ref 1 → 4}
- Toggle {Normalize} to On
- The position of the normalized trace is adjustable using {Norm Ref Pos}



Figure 6. Normalization establishes a 0-dB reference trace

Step 3.

Re-insert the DUT and make the transmission measurement.

- As the output of the tracking generator sweeps across the DUT (a band-pass filter in this example), we see the frequency response of the filter on the display of the analyzer. Normalization has enabled us to make a relative measurement and removed the frequency-response errors of the test setup.
- Press [Marker] > {Mode Normal} > {Delta} and set the marker delta to [-22.5] MHz or [22.5] MHz. The marker delta read out shows the rejection of the filter is above 30 dBc. See figure 7 and 8 for example.

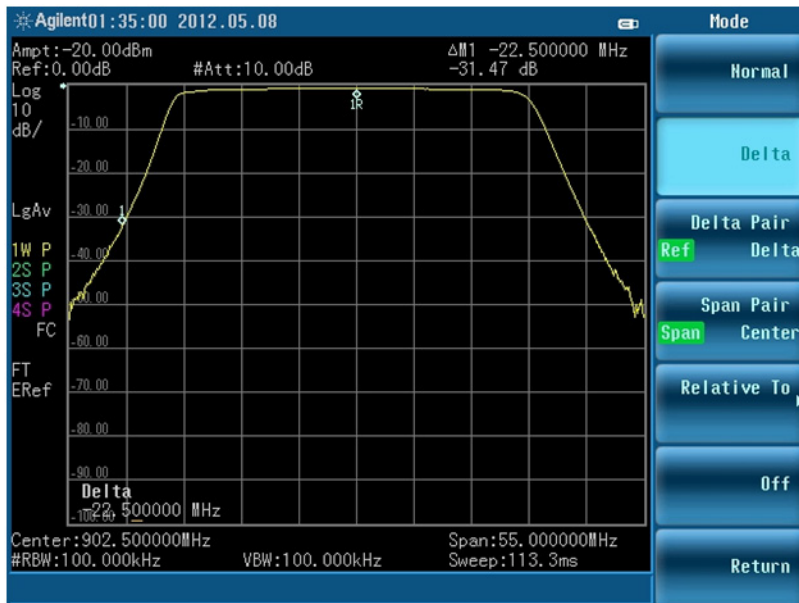

Figure 7. Marker delta readout shows the rejection greater than 30 dBc at 880 MHz

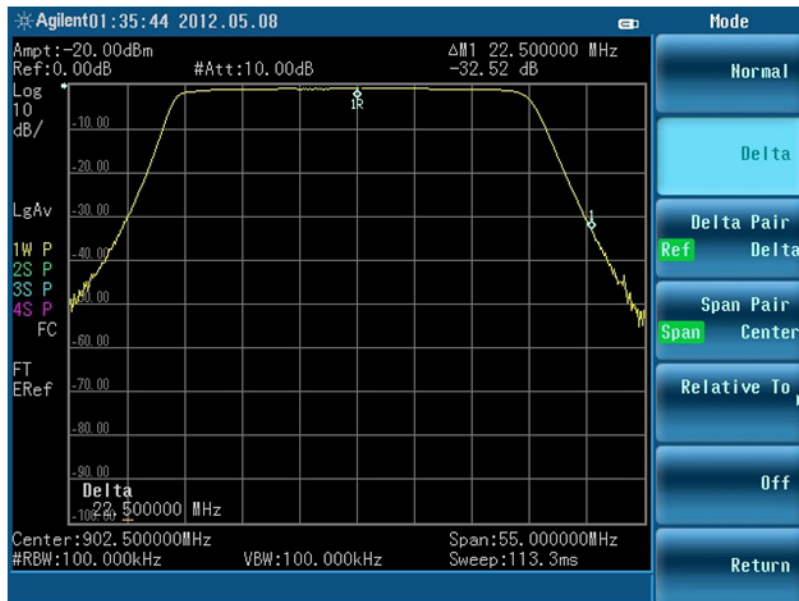

Figure 8. Marker delta readout shows the rejection greater than 30 dBc at 925 MHz

Summary

Adding a tracking generator to the Agilent N9322C basic spectrum analyzer (BSA) gives you the ability to make accurate stimulus-response measurements in addition to general purpose spectrum power measurements. As a receiver, a spectrum analyzer offers a large dynamic range and eliminates harmonics from the display. The tracking generator, as the companion source to a spectrum analyzer, allows simple transmission measurements to be made, such as attenuation, insertion loss, and gain.

Ordering Information

Product number	Description
N9322C	Basic Spectrum Analyzer, 9 kHz to 7 GHz
N9322C-TG7	Tracking generator, 5 MHz to 7 GHz
N9311X-546	N (Female) – N (Female) adapter, DC to 18 GHz



myAgilent

www.agilent.com/find/myagilent

A personalized view into the information most relevant to you.

Agilent Channel Partners

www.agilent.com/find/channelpartners

Get the best of both worlds: Agilent's measurement expertise and product breadth, combined with channel partner convenience.

Agilent Education Corner

www.agilent.com/find/edu

Your one-stop education resource for college and university engineering educators, researchers and students.



Three-Year Warranty

www.agilent.com/find/ThreeYearWarranty

Agilent's combination of product reliability and three-year warranty coverage is another way we help you achieve your business goals: increased confidence in uptime, reduced cost of ownership and greater convenience.



Agilent Advantage Services

www.agilent.com/find/AdvantageServices

Accurate measurements throughout the life of your instruments.



www.agilent.com/quality

www.agilent.com
www.agilent.com/find/n9322c

For more information on Agilent Technologies' products, applications or services, please contact your local Agilent office. The complete list is available at: www.agilent.com/find/contactus

Americas

Canada	(877) 894 4414
Brazil	(11) 4197 3600
Mexico	01800 5064 800
United States	(800) 829 4444

Asia Pacific

Australia	1 800 629 485
China	800 810 0189
Hong Kong	800 938 693
India	1 800 112 929
Japan	0120 (421) 345
Korea	080 769 0800
Malaysia	1 800 888 848
Singapore	1 800 375 8100
Taiwan	0800 047 866
Other AP Countries	(65) 375 8100

Europe & Middle East

Belgium	32 (0) 2 404 93 40
Denmark	45 45 80 12 15
Finland	358 (0) 10 855 2100
France	0825 010 700*
	*0.125 €/minute
Germany	49 (0) 7031 464 6333
Ireland	1890 924 204
Israel	972-3-9288-504/544
Italy	39 02 92 60 8484
Netherlands	31 (0) 20 547 2111
Spain	34 (91) 631 3300
Sweden	0200-88 22 55
United Kingdom	44 (0) 118 927 6201

For other unlisted countries:

www.agilent.com/find/contactus

(BP-3-1-13)

Product specifications and descriptions in this document subject to change without notice.

© Agilent Technologies, Inc. 2013
Published in USA, March 14, 2013
5991-1877EN



Agilent Technologies