

Agilent Technologies Considerations for Instrument Grounding Application Note



Agilent Technologies

Many people have heard of the term “grounding”, but few fully understand its meaning and importance. Sometimes, even experienced electricians do not treat grounding as a serious issue. The impact of an incorrect or absent grounding ranges from noise interference, resonance or humming during the use of electrical equipment to the worst case where electricity leakage through the chassis causes personal injury or damage to instrument components. Grounding, therefore, is a very practical issue that should be dealt with properly. For those who operate electrical equipment frequently, a complete understanding of grounding theories and applications is necessary in order to become a best-in-class technician.

In the eighteenth century, Benjamin Franklin performed the famous kite experiment to observe how lightning in the sky was conducted to the earth. This experiment led to the invention of lightning rods to avoid lightning strikes. From then on, people began to realize that the vast ground under our feet is a huge electrical conductor. It may not be the best conductor, but it is certainly a good one. It is so enormous in size that it can sustain a tremendous amount of current. That is why the voltage level of the ground is set to be zero. Safety regulations require that all metal parts which do not carry electricity should be kept at zero or the earth voltage level.

There are several reasons for grounding. Some are for safety purposes, and some are for maintaining circuit stability. The following are some examples:

- (1) Power system grounding: As you can see in **Figure 1**, this design is to prevent the secondary side from being damaged by the high voltage on the primary side, as the current will be conducted to the ground through the Grounding Wire to protect human lives.
- (2) Instrument grounding: By connecting the equipment or chassis to the ground, operators can be protected from electric shocks if there is electricity leakage.
- (3) Signal grounding: A zero voltage reference or a loop-back path is provided for all integrated signals to ensure proper operation or accurate measurements.
- (4) Shielded grounding: This is used to prevent static electricity from being accumulated. Ground isolation or conduction can help to reduce noises and electro-magnetic interference. Examples include shielding rooms, cables, wirelines, guarded terminals of instruments, transformers and filters.

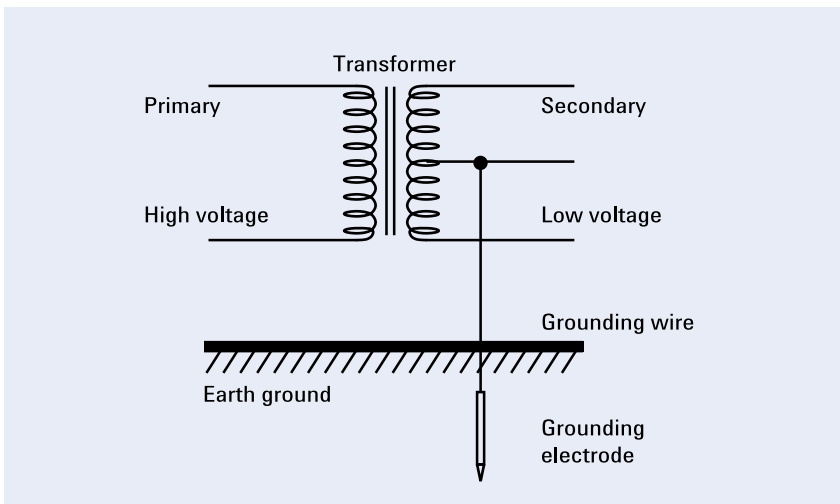

▲ Figure 1

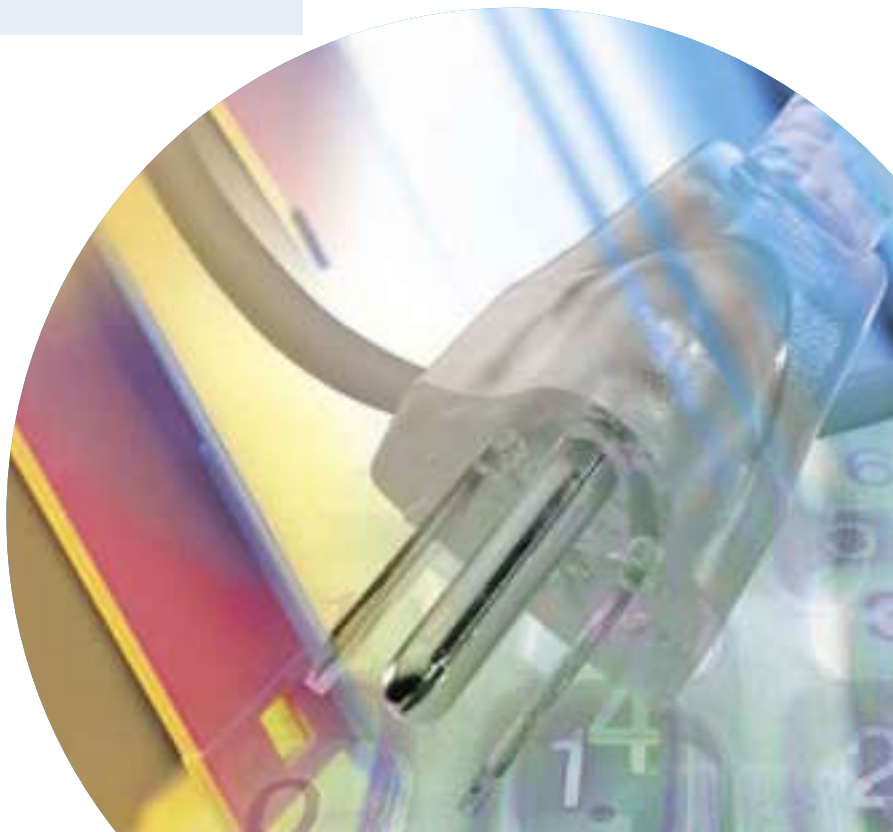

Types of Instrument Grounding

(1) **Figure 2** shows a commonly used instrument grounding on inputs and AC power. In this case, the input signal ground is connected to the power ground and when you are making a measurement, it is important to make sure that the input signal ground is not short-circuited directly to any point where there is a voltage difference to the earth ground. This is very common when measuring commercially available low-cost circuits. To reduce costs, these circuits usually do not use power isolated transformers. Instead, the AC power is directly connected to the circuit. As a result, a loop is formed between the circuit itself and the earth ground, and a

voltage difference occurs. If the AC power happens to be plugged in the reverse way, or a considerable voltage difference exists between the neutral line and the earth ground, the combined factors could lead to very unpredictable results. Therefore, caution must be exercised before the input is connected for measurement.

(2) To avoid the problem described above, some instruments provide floating inputs as shown in **Figure 3**. Each of the inputs is floating from the earth ground. Ideally, as long as the voltage difference between these two inputs is within an acceptable range, the inputs can be connected to any voltage point.

(3) **Figure 4(a)** and **4(b)** show some common instruments for output devices. For DC or low frequency generators, the design shown in 4(a) is usually adopted, while for high frequency (RF) generators, the model in 4(b) is used. Therefore, special attention is required to avoid the problem described in item (1) when performing a high frequency measurement. Otherwise, the voltage difference and conflict may cause damage to the input and output of instrument circuits.

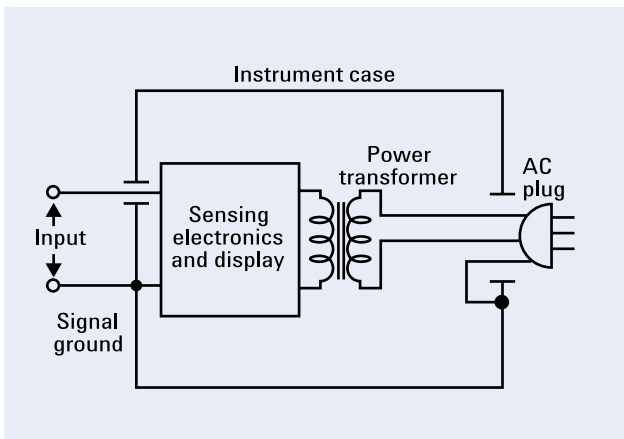

▲ Figure 2

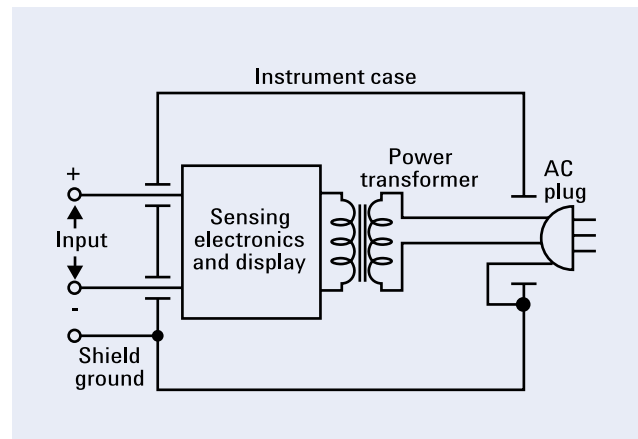

▲ Figure 3

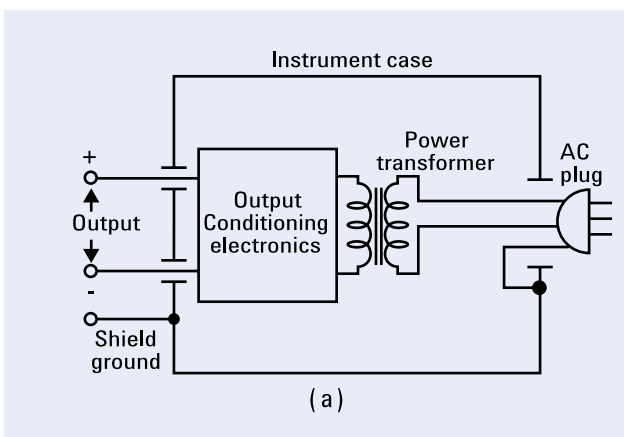

(a)

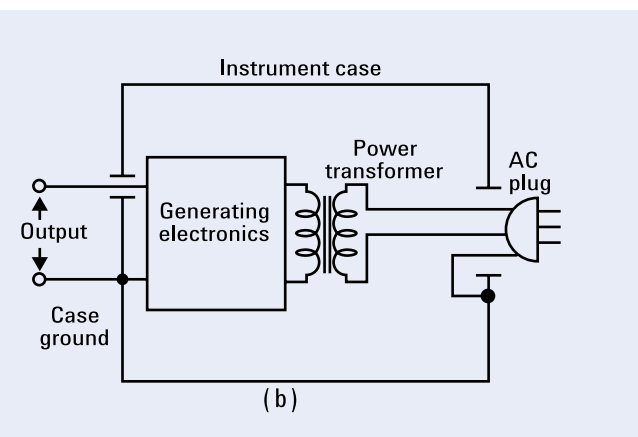

(b)

▲ Figure 4

Guidelines for Instrument Grounding

While there are some guidelines for grounding, there is no hard and fast rule. In practice, it is difficult to follow all the guidelines. Rather, it is dependent on the environment and applications. For instance, before the measurement is performed, evaluations should be made to decide whether the floating method should be used. The following are some general guidelines:

- (1) When dealing with different kinds of grounding such as shielded grounding, power grounding and signal grounding, make sure that they are guided to their own paths to avoid interaction.
- (2) Keep the impedance of the ground line low and the path short.
- (3) Avoid multiple ground loops, which may disturb current flows
- (4) Isolate the heavily loaded ground current loop from the small signal loop.

Let's take a look at the example in **Figure 5**. For a well-designed power supply equipment, the voltage ripple between output A and B should be very small. However, if for convenience sake, point C instead of point D is used as the signal's ground reference, a significant pulse voltage will occur

and show up on the output circuit even when the resistance between point C and D is small. This is because the transient current in charging or discharging the capacitors is usually very high. As a result, as soon as the power is on, damage can be caused to the connected circuits or instruments.

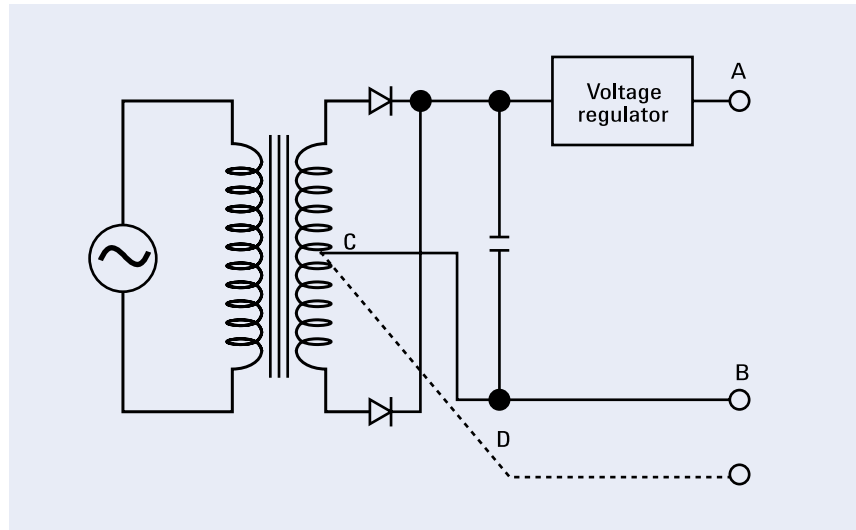

▲ Figure 5



Common Causes of Poor Grounding

- (1) The AC power (such as 110V) socket does not provide the ground line (green), as shown in **Figure 6**. The earth pole on the plug is usually the longest, so that it can be connected to the ground first when the AC power cord is plugged into the socket.
- (2) The actual impedance to the ground is too high which does not comply with electrical regulations (please refer to the appropriate regulations in your country). Take the example of the third level regulation of grounding. When the AC voltage to the ground is above 300V, the impedance to the ground must be less than 10Ω . If the AC voltage to the ground is under 150V, the impedance to the ground should be within 100Ω .
- (3) The neutral line is mistakenly used as the ground line and these two lines are short-circuited together on the socket. Under normal conditions, the voltage difference between the neutral line and the ground line on the socket must be within 1.0V, but this should not be accomplished by short-circuiting these two lines together.
- (4) Swap the hot line and the neutral line arbitrarily. Take **Figure 7** as an example. Equipment A sends out signals while equipment B receives signals. Suppose the AC power sockets to which Equipment A and B are connected do not provide the ground line, and the hot line and neutral line are swapped on one of the equipment. Since equipment A and B both have noise filters installed, a 110V AC loop is therefore formed accidentally even when the power switch of A and B is not connected.

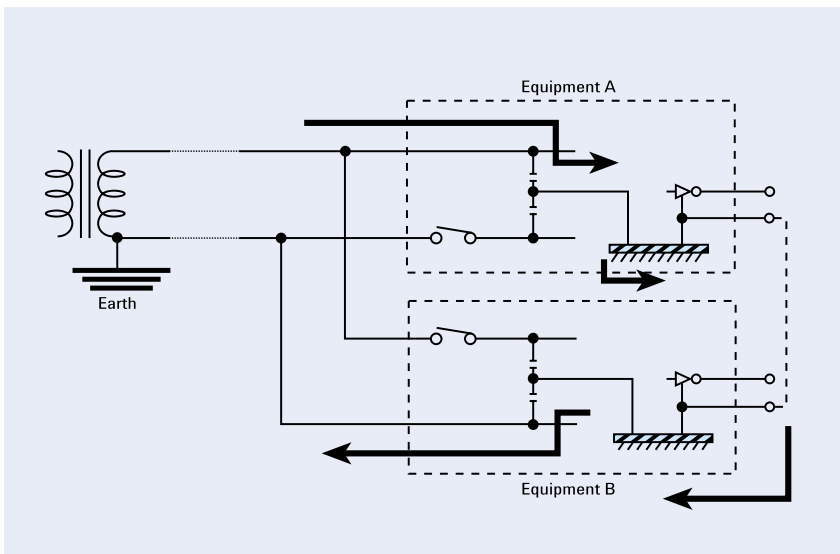

▲ Figure 7

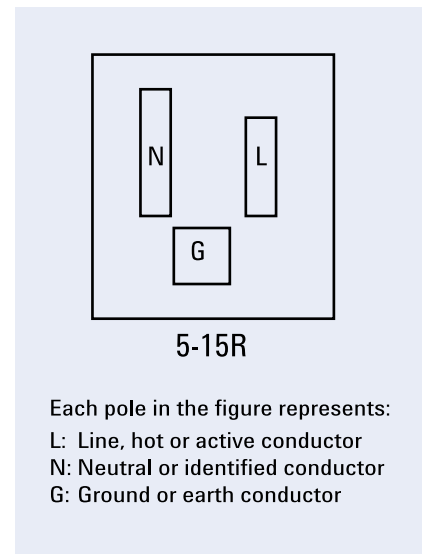

▲ Figure 6

Summary

- (1) When installing the equipment in a building, make sure to have an electrician check on the impedance to the ground and the grounding device to see if they comply with electrical regulations. 8AWG wireline should be used as a minimum wire type for instrument grounding.
- (2) Use the three-pole AC power socket for the instrument. Make sure the polarity of the hot line and the neutral line is correct (see **Figure 6**). The voltage difference between the neutral and the ground lines should be less than 1V. At the socket end, the impedance between the neutral and the ground lines should be lower than 1 Ω .
- (3) Find out the appropriate way to do measurements, i.e. whether the instrument 's input/output terminals should be grounded or be floating.
- (4) Check the stability of the AC power (ex. +5% to -10% within 120V) and whether there are unpredictable impulses, which may cause the measurement to fail or even damage the instrument. Generally, the transient voltage fluctuation should not exceed $\pm 15\%$ within 120V and the voltage should be restored to 120V within 0.5 second. The total harmonic component should be less than 5%.
- (5) Verify the grounding of the equipment or device under test (DUT). If voltage differences exist among equipment, connecting them together may cause conflicting situations. The sudden pulses generated when the equipment is powered on may also damage vulnerable modules. If this happens, the links between the equipment and devices under test should be disconnected before the AC power is turned on. Each equipment and DUT should be reconnected only after all equipment and devices have stabilized. In so doing, the possibilities of damage can be minimized. However, this is not the way to eradicate the problem completely. The best solution is to identify the root causes and fix them.
- (6) Reduce and remove unwanted static, interference and noise through proper grounding.

Agilent Test and Measurement Service Centers have been providing comprehensive and precise repair and calibration services to customers for many years. Our pursuit of quality and technical innovation enables us to offer better services to our customers. By sharing this article with you, we hope to help you improve the accuracy of measurements and the life span of your instruments.



Appendix 1: AC Power Control Panel

In most countries, electric power companies will provide building occupants AC power electricity with a Y connection configuration (Figure 1), which offers three live/hot lines (a),(b),(c) and one neutral line that is colored white. This configuration is called a 3-phase 4-wire AC power system. The voltage between either one of the live lines and the neutral line is about 108~126V, while the voltage between the two live lines is about 187~218V. The neutral line inside the AC power transformer is connected to earth, which – in the event of an AC power transformer failure – bypasses a potentially damaged current into the ground, thus preventing any damage to the occupant's equipment. This neutral line also performs as a reference point for balancing three phase voltages.

Builders should provide one independent grounding line (G) colored green, with a resistance of about 1 ohm, connected to the AC power control panel. It is not the responsibility of the electric power company to provide this. In many cases, either the builder or the occupant may overlook this step, resulting in a missing grounding wire, or the neutral line being mis-used as the ground line.

The neutral line (N) should not be used as the ground line. The key concern is that the dynamic loading current, which flows through the neutral line, creates a voltage drop between it (N) and the earth. If the loading current is high, then the voltage drop will be significant. However, in normal circumstances there is no loading current in the ground line and the voltage drop between (G)

and the earth is zero. So when we connect the instrument chassis to the ground line, we can obtain an extremely stable and safe reference plane. Moreover, if electricity leakage or ESD occurs, the current will flow to the earth, thereby protecting the instrument. Usually, the voltage drop between (N) and (G) should be within 1 volt AC; it is impossible to achieve zero volt. For precision instrument measurements, if the ground line is left open or is connected to the neutral line, this means we have failed to set up an independent grounding for the instrument. Hence, an ideal grounding reference level required for safe and stable measurement cannot be achieved. In the worst case, when the voltage difference between the instrument chassis and the ground is too high, it may damage the other instrument or the device under test in the same measurement system.

Electric Power Control Panel

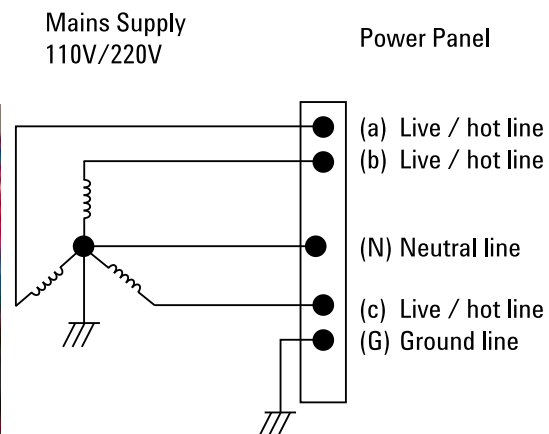
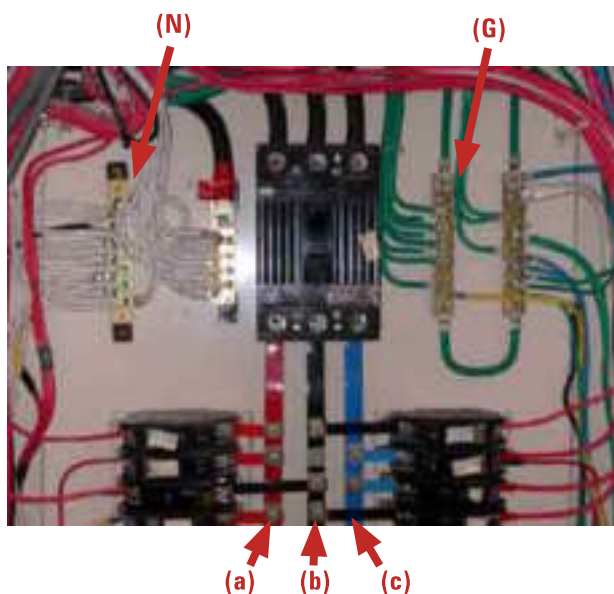

Neutral line (N): Dynamic current flows through it. If wire resistance is high, there will be a significant voltage drop with respect to the earth. (i.e. there is voltage between N and G)

Ground line (G): Normally there is no loading current and voltage drop is zero with respect to the earth. Ground line is connected to the instrument chassis, which protects the operator and offers an ESD bypath.

▲ Figure 1

Appendix 2: Guide on Testing Power

This is to remind you once again. Please check the AC alternating current (use 120V as an example) and grounding condition prior to the use of an instrument. If the following basic

requirements are not met, please do not connect it to the power source. Otherwise, the instrument is extremely vulnerable to damages. This may even lead to dangers to human body.

- **Step 1**

Make sure there are 3 holes in the outlet, that is, holes for the Live wire, the Neutral wire and the Ground wire. Do not put on the plug if the outlet is not with 3 holes.

(As on **Figure 1**)

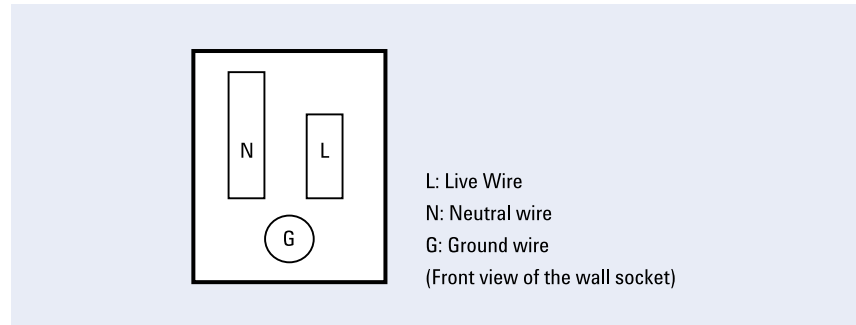

▲ Figure 1

- **Step 2**

Make sure the polarity of the 3 wire outlet (**Figure 1**) is correct: can be tested with

- (a) Polarity Tester on **Figure 2** to find the polarity via the red, white and yellow lamps or
- (b) Multi-meter and refer to the test in Step 3

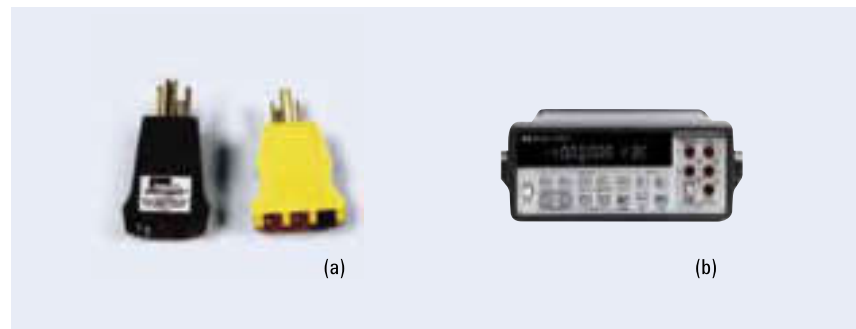

▲ Figure 2

- **Step 3**

Use a multi-meter to test the followings: The voltage between the Live wire and the Neutral wire should be in the range of 108~126V. The Voltage surge should not exceed $120V \pm 15\%$. The voltage between the Neutral wire and the Ground wire should be less than 1.0V. At the same time, the change should not be more than 1.0V no matter whether the instrument is on or not.

(As on **Figure 3**)

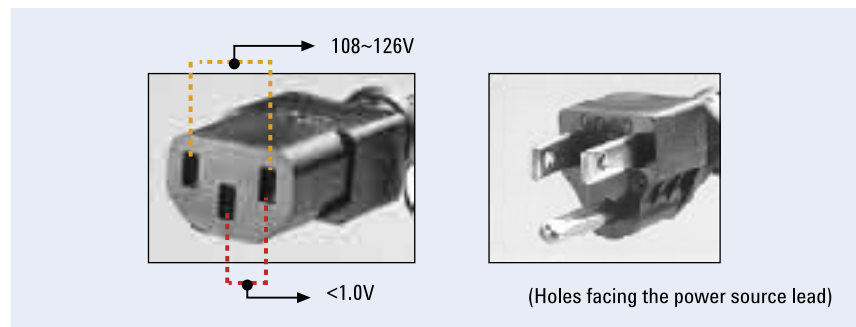

▲ Figure 3

Appendix 3: Serious Damage comes from incorrect polarity and grounding of AC 3-Wire

Question 1

Why is instrument grounding so important?

Question 2

Why is the polarity and grounding of AC power source so important?

Question 3

What is the threat of AC power source on the Device-under-test to the instrument?

Figure 1: If we only use the Line and the Neutral Conductor of AC 120 Volts but do not really connect the Ground Wire, voltage will exist between the Ground Wire (and the chassis) and the ground! This is because there is still stray capacitance between the Neutral conductor and the Ground Wire of the power cable or the primary winding of the transformer. Or, there is filtering capacitor for suppressing noise. As V_{g1} or V_{g2} on the diagram, it may be as high as 20V~60V! If the Live and the Neutral wires are reversely connected in one of the instrument, $V_{g1} \neq V_{g2}$. Simply imagine what will happen if two objects with different electric potential are put together.

Figure 1: When V_{g1} and V_{g2} exist, the signal (to the ground) output of Instrument 1 is no longer smaller than v_1 . Instead, it is $(v_1 + V_{g1})$. This signal is strong enough to seriously damage the input circuit of Instrument 2. The signal will not only circulate between the output ends of Instrument 1 and input ends of Instrument 2. I_g will flow through the floating ground wire. If the circulation is too strong, permanent damage will be caused! Therefore, only perfect grounding can solve this problem. $V_{g1} = V_{g2} = V_{g3} = 0$ and makes $I_g = 0$.

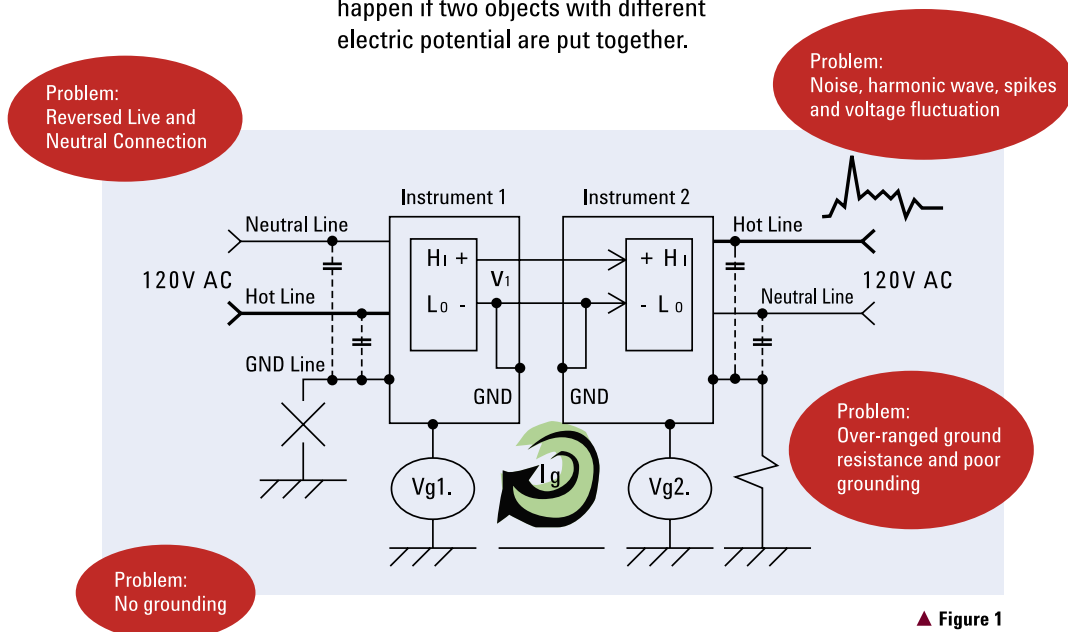

▲ Figure 1

Figure 2: When the Device-under-test is an active component or circuit, it may sometimes rely on 120V AC (but not battery) as a source of power. This device usually uses only 2 wires (Live wire and Neutral wire) and is not connected to the ground due to costing and commercial use factors. There may not be even any isolating transformer in the circuit. Therefore, there may be an unexpected V_{g3} voltage. This usually happens in tests using LNB and CATV Amplifier. Without sufficient care, I_g will cause damages.

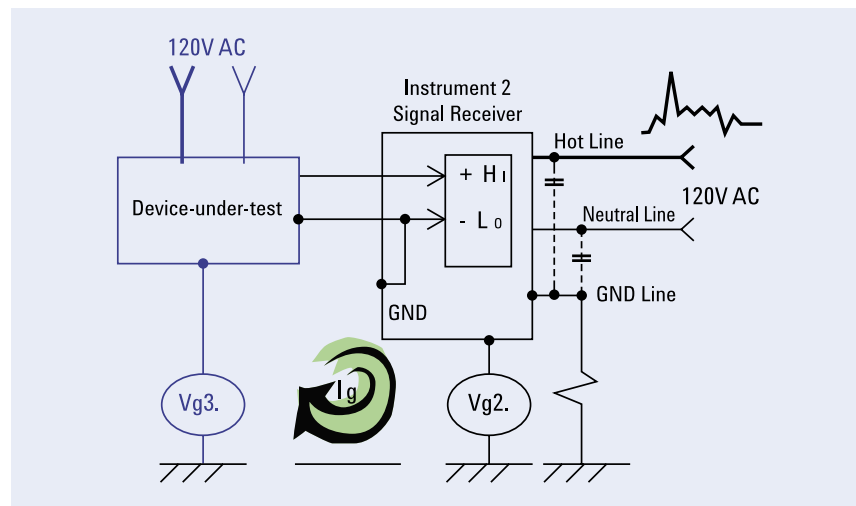

▲ Figure 2

Figure 3: If the instrument chassis is not grounded. When there is an AC voltage through it (the operator sometimes may not feel the electricity when he touches its chassis), how can the instrument be damaged under such conditions?

The facts are:

(A) If the chassis of both instruments (1) and (2) are grounded correctly, both instruments will not have any voltage difference with respect to the earth.

(B) Because the instrument is using a 3-pronged power source, the ground line inside the power cord is located

in parallel between the live/hot line and the neutral line, and this will create a stray capacitance between these 3 wire lines. So if the neutral line, instead of the ground line, is connected to the earth, a voltage of about 30V~60V will be coupled to the ground line with respect to the earth. This voltage will appear on the instrument chassis and may injure the operator or damage any DUT and other connected instruments.

(C) When any DUT or other instruments connected to the instrument are not grounded, this unexpected 30V~60V voltage will find

another circuit loop to release the power. It will generate a current surge and will damage any sensitive DUT or instruments in the circuit loop. However, if the chassis (ground line) of both instruments are connected beforehand to form an equal potential, the destructive current loop will not result between instruments (1) and (2). This explains why operators do not always find damage to their instruments, even though they do not take instrument grounding precautions. The key principle is that we should connect L1 to L2 before connecting H1 to H2 for setting up a good reference plane.

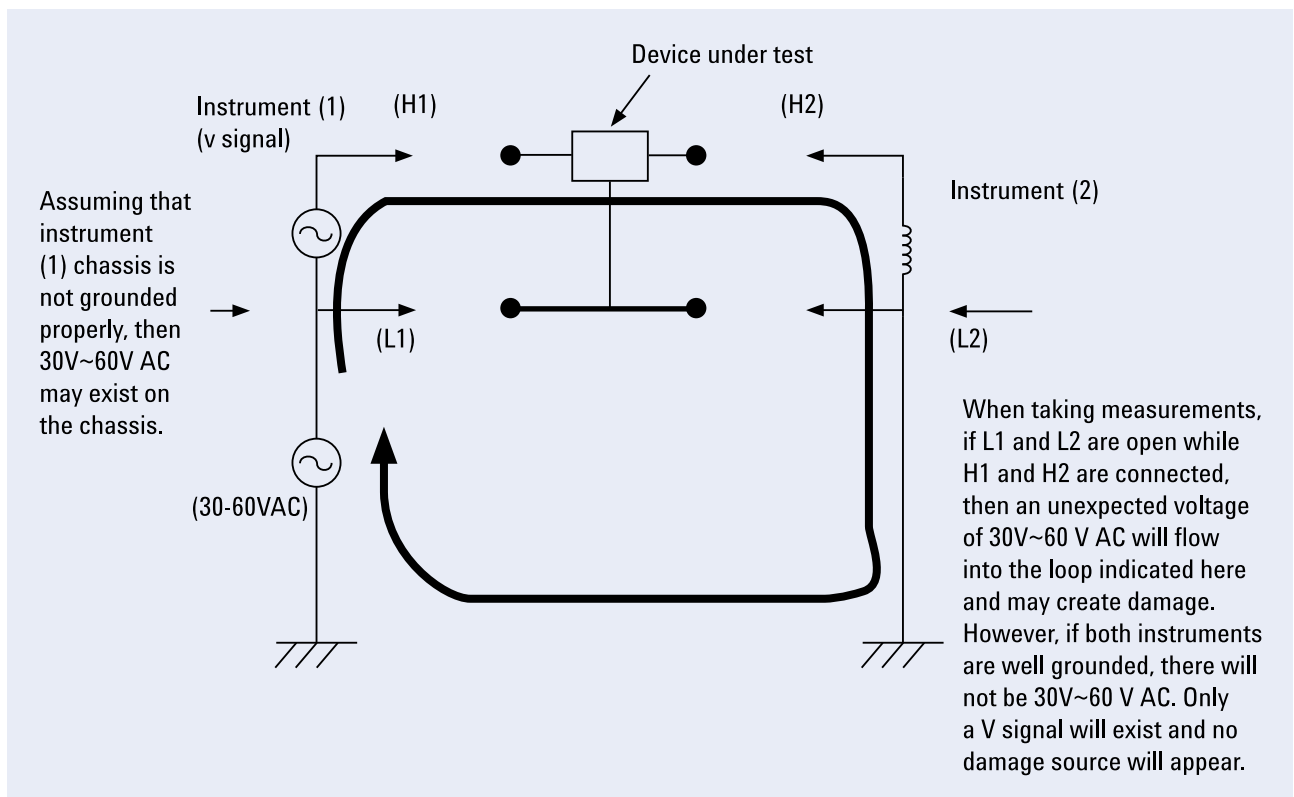

▲ Figure 3

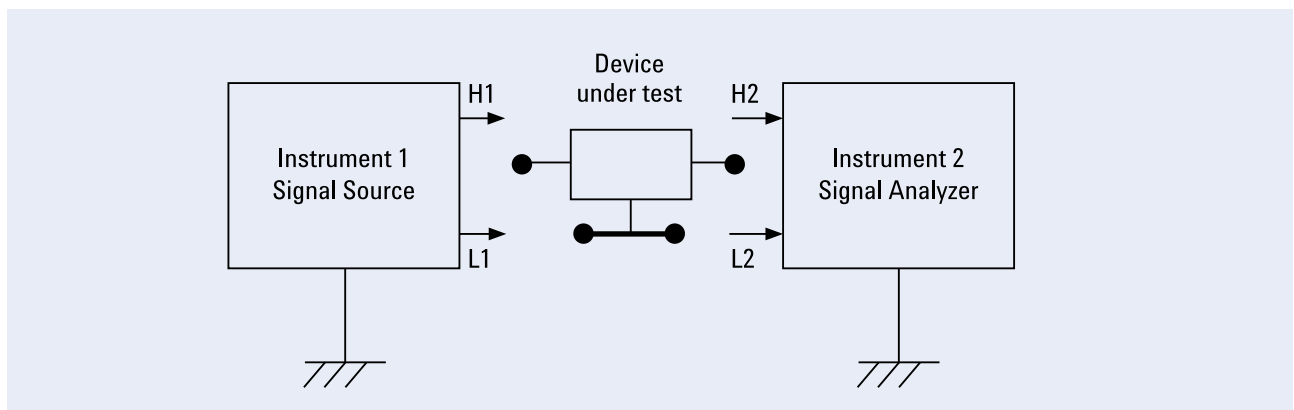

Appendix 4: Bench Instrument Quick Check Table

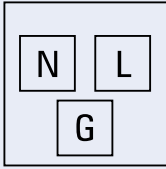
	Check Items	Expected Spec.	Tools	Check Results
<input type="checkbox"/> . AC power quality				
1.	3-wire polarity	 <p>AC Power outlet, N-G voltage less than 1VAC (but N & G can't be shorted on the outlet), N-L voltage 120 VAC.</p>	DMM PGT-602 Receptacle Tester1933 GAM-2A	
2.	Voltage & Impedance between neutral & ground line (under full load)	Should be less than 1VAC & 1 ohm. Grounding wire spec. 8AWG, independent ground wiring.	PGR75 Fluke 434 PGT-602	
3.	Stable voltage, single phase 120 volt	120V or 208V+5%, -10% (i.e. 108V~126V, 187V~218V)	Fluke 434 RPM 901	Phase A to Neutral: _____ Phase B to Neutral: _____ Phase C to Neutral: _____

	Check Items	Expected Spec.	Tools	Check Results
4.	Frequency	60 cycle (Hz)+-0.5 cycle	Fluke 434 RPM 901	
5.	Surge & Sag Voltage	Less than 120V+-15%, can endure for max. 0.5 Sec (30 cycle)	Fluke 434 RPM 901	
6.	Impulse, Transient Voltage	If transient voltage > 100VAC (up to 200us), equipment may damaged. Normally, ETE can stand for 150%~200% VAC with max.0.2 second	Fluke 434 RPM 901	
7.	Total Harmonic	Less than 5%	Fluke 434 RPM 901	
8.	Power Factor	0.8~0.9	Fluke 434 RPM 901	
9.	3-phase unbalance ratio	Less than 2.5%	Fluke 434 RPM 901	
10.	3-phase load unbalance ratio	Each phase max. 5%~20%	Fluke 434 RPM 901	
<input type="checkbox"/> . Environment:				
11.	Temperature	20°C -25°C best with 23°C		
12.	Humidity	40%~60% best with 50%	Testo 615	
13.	Air dust	The particle quantity should be less than 45,000 pieces within each cubic fee for those particle size >0.5Micron.		
14.	Vibration	Less than 0.5g		
15.	EMI	Less than 0.5 V/M, Frequency range : 14KHZ~1GHZ		
<input type="checkbox"/> . ESD process:				
16.	ESD floor, desk, Chair, mat, cloth, hat, shoe, wrap, bag, transit box, etc.	Floor resistance > 150Kohm, < 20,000Mohm. Refer to specific product spec, the surface resistance are between 103~1010 ohm, please refer to product data sheet.		
17.	ESD Fan	By necessary		
18.	ESD Charge measurement	For specific product, it may be able to just endure several volts ESD only.	ACL300 ME-282A	