

Photonic Foundation Library : Enhancing Swept Loss Measurements

Application Note
Gunnar Stolze



Abstract

The Photonic Foundation Library (PFL) is a function library containing the most-demanded test and measurement functions. The library is designed to simplify the development and integration of passive optical component test solutions.

This application note describes the measurement functionality and the accuracy enhancements enabled by the know-how contained in the Photonic Foundation Library.



Agilent Technologies

Introduction

The Photonic Foundation Library (PFL) is a function library containing today's most demanded measurement and analysis functions for the test of passive optical components. The PFL is designed to work with the Agilent Lightwave Measurement System 816x¹ in order to achieve the highest accuracy and measurement speed, while maximizing the effectiveness of building a swept-wavelength test and measurement solution for passive components.

The present application note is organized as follows:

- Requirements of Optical Component Test Solutions
- Generic Loss Measurement Solution – Stimulus-Response Test
- Swept-Wavelength Multichannel Loss Measurements
- Loss Measurement Principles
- Photonic Foundation Library Loss Measurement and Analysis Functions
- Photonic Foundation Library Accuracy Enhancements
- Use Cases

To understand the necessity and usefulness of a function library such as the PFL, the introduction describes the various requirements facing optical test solutions today and tomorrow.

The first part of the paper reviews the fundamental measurement principle, the so-called stimulus-response test, and what real-life solutions look like today. Furthermore, a short introduction to the basic loss measurement principles is given, omitting great detail.

Then, insights into the functionality of the PFL with respect to loss and PDL measurement and trace analysis functions are given. Enhancements to measurement accuracy enabled by the PFL are then described. The last section explains how typical test applications can be implemented by using the Lightwave Measurement System 816x and the PFL.

Requirements of Optical Component Test Solutions

Passive component test solutions are faced with a number of different requirements. To understand the capabilities and advances of the PFL, these requirements are briefly discussed in the following paragraphs.

DWDM component manufacturers are experiencing a dramatic need to reduce the cost per device. The ultimate (although more idealistic) goal in any manufacturing environment is to maximize throughput and achieve a hundred percent yield while minimizing production cost. The problem that immediately arises is how to ensure yield but not sacrifice throughput. Quality management always relies on tools that test the output (e.g. the product itself) of each major manufacturing process. Verification or characterization tests are important and common quality management tools. However, each test procedure reduces the throughput by introducing test times. Hence, the cost per product increases. The relation between throughput, yield and cost is actually very complex and has been described in detail in Ref.[1]. It is obvious, however, that optical component test solutions must address these manufacturing requirements. Flexibility in the application is as important as easy and fast integration of complex test solutions. Fast and accurate measurements can reduce the impact on throughput and at the same time, enable quality control.

The other factor that comes into play when talking about optical component test solutions is the evolution of the optical network, especially in the DWDM component segment. In order to increase bandwidth, four approaches are being taken:

- increase the transmission rate,
- increase the number of channels,
- decrease channel spacing,
- exploit a wider wavelength range.

This evolution has a direct effect on measurement solutions, which must be capable of testing such technologically advanced devices.

For example, consider the impact of channel spacing reduction. To accurately resolve the transmission characteristics of narrow channels, the wavelength accuracy and resolution of test solutions must always be one step ahead. Otherwise, the test equipment would limit the achievable component specification.

Clearly, all the above requirements for passive components represent a great challenge for the design of optical test

¹ The Lightwave Measurement System 816x is a generic term referring to the portfolio of test equipment that is compatible with Agilent's component test platforms 8164, 8166 and 8163, such as tunable laser sources, power sensors and optical heads, polarization controllers etc.

solutions. Basically, the requirement of measurement solutions comes down to: *Measure quickly and accurately!*. The PFL in conjunction with Agilent's Lightwave Measurement System 816x allows addressing the throughput and cost issues on one side as well as measurement accuracy on the other side.

Generic Loss Measurement Solution – Stimulus - Response Test

The most basic principle of passive optical component testing is the so-called "stimulus-response test", Figure 1. The device is stimulated with an optical source and the response depending on variable input parameters, like power, wavelength or state of polarization (SOP) is recorded. The response may be captured in the transmission or reflection path of the device under test (DUT). This way, loss parameters such as insertion loss, polarization dependent loss (PDL) or return loss can be determined. Often, it is required to characterize the device over wavelength, i.e. performing a "spectrally resolved stimulus-response test". For this, one could either use a broadband source and a wavelength-selective receiver, such as an optical spectrum analyzer (OSA), or a tunable laser source (TLS) in combination with a broadband receiver. Tunable laser sources usually exceed the wavelength resolution limitations of OSAs.

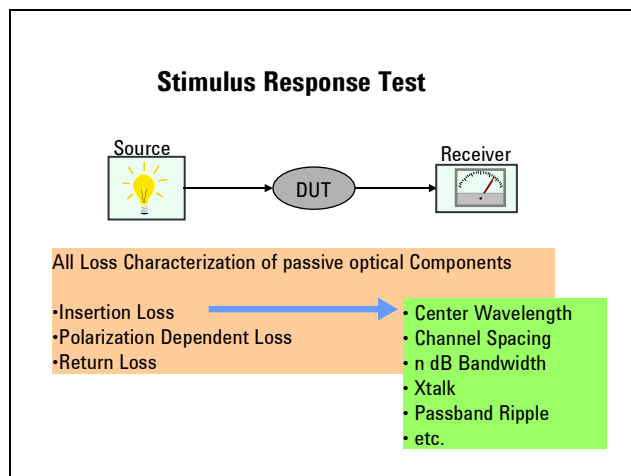

Figure 1: General Stimulus Response Test.

Swept-Wavelength Multichannel Loss Measurements

A general swept-wavelength stimulus response system is shown in Figure 2. The solution makes use of a tunable laser, capable of continuously tuning the wavelength (at various speeds), as the wavelength-selective instrument. For signal conditioning, a polarization controller may be included in the setup if the polarization dependent loss of the device under test is needed. Broadband optical power sensors or optical heads serve as the signal-response modules.

When considering dynamic range, one of the biggest problems with using a standard tunable laser source is called Source Spontaneous Emission or SSE. All laser diodes show this source noise effect. SSE is the sum of all spontaneous transitions inside the laser diode. It has a broad spectral characteristic, but is weak when compared to the laser line itself.

Because a photodiode integrates over a broad wavelength range, SSE can have a severe impact on filter measurements, mainly in smearing out the filter's spectral response. To overcome the limitations of standard tunable lasers, the source spontaneous emission of the laser is reduced by design. This way, a higher dynamic range can be provided [2].

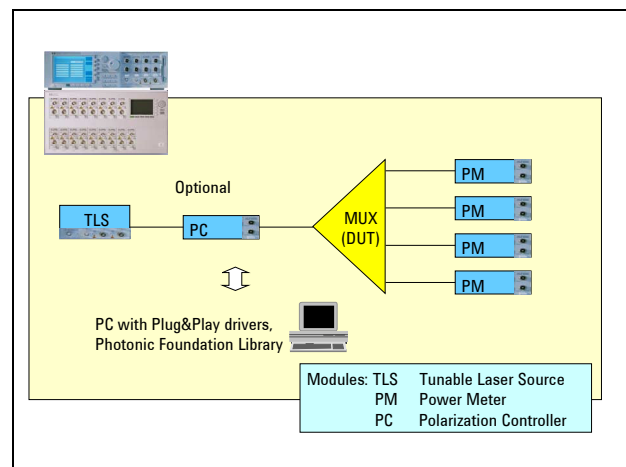

Figure 2: Swept-wavelength multichannel stimulus-response test system for insertion and polarization dependent loss measurements.

The considerations about noise effects are valid for bandpass as well as notch filters. Although the spectral range with high transmission is not as broad as in the notch filter case, a higher dynamic range can still be achieved by using the Low SSE output [3].

To ensure wavelength accuracy in swept-wavelength systems, the wavelength during a sweep must be captured. Agilent’s tunable laser sources contain a built-in real-time wavelength meter. A more detailed discussion follows below.

A swept-wavelength system as described here takes both wavelength and power data over time. Synchronization between both measurements is achieved using a trigger line. This way, multiple channels can be measured in parallel, because the triggering line ensures that a measurement sample is taken at all desired power meter channels.

Such a swept-wavelength multichannel system is well suited to measuring insertion loss and PDL over wavelength fast and accurately. The next part of this application note gives a brief description of insertion loss and polarization dependent loss.

Loss Measurement Principles

Insertion Loss

Perhaps the most important characteristic for passive optical components is the insertion loss value. It is also the easiest measurement to perform. For (D)WDM components, the insertion loss is usually measured over wavelength. Other component parameters such as bandwidth, center wavelength, crosstalk or ripple can be derived from the spectral loss measurement, as shown in Figure 3.

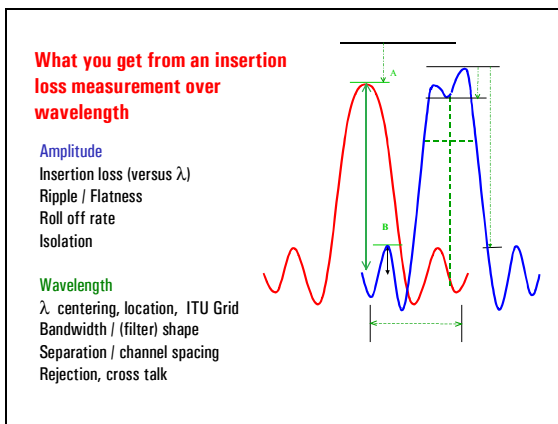

Figure 3: Channel parameters that can be derived from an insertion loss measurement over wavelength.

The insertion loss value is the ratio of two power values: a reference power, P_{REF} , that captures the loss (over

wavelength) of the setup only, and the power P_{OUT} measured, with the DUT inserted into the measurement setup:

$$IL_{dB} = 10 * \log\left(\frac{P_{OUT}}{P_{REF}}\right).$$

Equation 1: Definition of insertion loss.

Calibration with the reference power minimizes the influence of the measurement setup on the actual DUT’s insertion loss value.

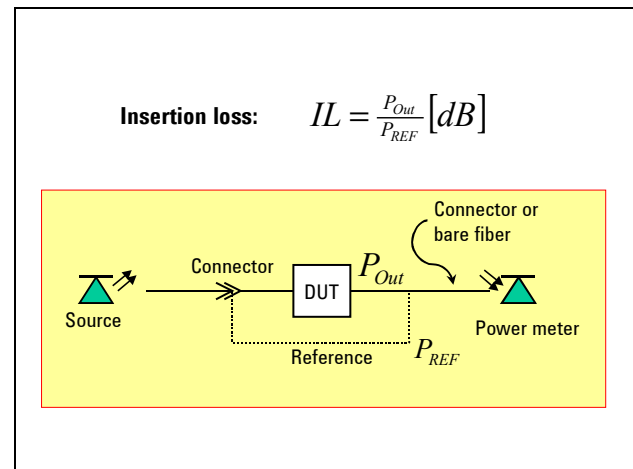

Figure 4: Principle of an insertion loss measurement.

Measuring insertion loss takes two steps.

1. The reference power, the power P_{REF} without the device under test (DUT) must be recorded. This is indicated with the dashed line in Figure 4.
2. Then the DUT is inserted and the output power P_{Out} after the DUT is measured.

Polarization Dependent Loss

Polarization dependent loss (PDL) is a measure of the peak-to-peak difference in transmission of an optical component or system with respect to all possible states of polarization. It is the ratio of the maximum and the minimum transmission, as depicted in Figure 5.

Polarization Dependent Loss is defined as:

$$PDL_{dB} = 10 * \log\left(\frac{P_{Max}}{P_{Min}}\right).$$

Equation 2: Definition of polarization dependent loss.

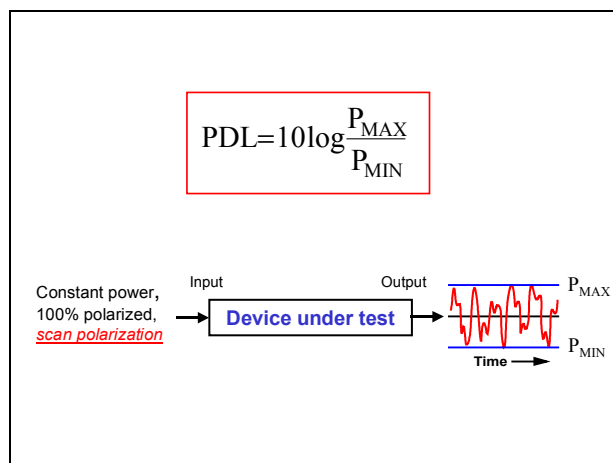

Figure 5: PDL generates a varying output power over different states of polarization.

PDL has attracted enormous attention among component manufacturers. Practically every component exhibits a polarization dependent transmission. As polarization of the transmission signal is not constrained in fiber optic networks, this means that the insertion loss of a component varies. The effect can grow in an uncontrollable manner along a transmission link with severe consequences for the transmission quality. It may even lead to a failure of the network [4].

With wavelength-selective components the polarization dependent loss varies over wavelength, corresponding to the transmission and rejection band characteristics of the device.

One way of measuring PDL utilizes the Polarization Scrambling method, which directly yields the loss variation, and hence the PDL, by randomly scrambling the input stimulus light across all applied states of polarization.

The Mueller method is the second common technique to determine PDL over wavelength. The Mueller method takes advantage of the fact that the DUT's transmission need only be recorded at four well-defined states of polarization, and thus can be incorporated with swept (continuously tuned) wavelength scans at each of the polarization states. This reduces measurement time significantly, if a well-resolved spectral image of the component's PDL properties is required. After the insertion loss over wavelength is measured at four well-defined input polarizations, the average insertion loss and the PDL can be derived based on Mueller-Stokes calculus. The Mueller method is thus not a direct measurement of the PDL. A typical setup of a PDL measurement using the Mueller method is shown in Figure 2. It utilizes the swept-wavelength multichannel capability provided by the tunable laser source and power meter arrangement.

A polarization controller, such as the 8169A, serves as the signal-conditioning element. The controller is placed in front of the DUT to control the SOP of the light incident on the DUT. The polarization controller consists of a polarizer, a quarter-wave and a half-wave retarder, which generate polarization states deterministically.

A polarization-dependent loss measurement following the Mueller method takes two steps:

1. Four reference measurements over wavelength must be performed, one at each of the four polarization states.
2. Then, the DUT is inserted and the transmitted power over wavelength at each of the four polarization states is recorded.

Note the analogy to the insertion loss measurement.

The reference measurement is required to calibrate for influences of the measurement instrumentation itself, mainly of the source and polarization controller.

The calculation of the PDL is based on Mueller-Stokes calculus, a means to analytically obtain the polarization transformation of a component or system.

An incident lightwave, characterized by the Stokes vector S_{in} , interacts with the component. The output lightwave can be described by a second Stokes vector. The polarization transformation of the component or system is denoted by the Mueller matrix, a 4x4 matrix:

$$S_{Out} = M \times S_{in}.$$

The above equation represents a set of four linear equations. To determine the PDL, only the first row coefficients $m_{11}..m_{14}$ of the Mueller matrix are required. In other words, only the first equation is of interest for PDL, because S_{Out} denotes the total optical output power:

$$S_{0_{out}} = m_{11}S_{0_{in}} + m_{12}S_{1_{in}} + m_{13}S_{2_{in}} + m_{14}S_{3_{in}}.$$

One of the advantages of the Mueller–Stokes calculus is that the coefficients of the Stokes vector are measurable in terms of optical power. The optical input powers, determined in the first measurement step, are denoted with $P_a, P_b, P_c,$ and P_d . The optical output powers are described as $P_1, P_2, P_3,$ and P_4 . Then, the above equation can be rewritten for all four polarization states as:

$$\begin{aligned} P_1 &= m_{11}P_a + m_{12}P_a \\ P_2 &= m_{11}P_b - m_{12}P_b \\ P_3 &= m_{11}P_c + m_{13}P_c \\ P_4 &= m_{11}P_d + m_{14}P_d \end{aligned}$$

Solving this linear equation system for the first row coefficients of the Mueller matrix yields²:

$$\begin{bmatrix} m_{11} \\ m_{12} \\ m_{13} \\ m_{14} \end{bmatrix} = \begin{bmatrix} \frac{1}{2} \left(\frac{P_1}{P_a} + \frac{P_2}{P_b} \right) \\ \frac{1}{2} \left(\frac{P_1}{P_a} - \frac{P_2}{P_b} \right) \\ \frac{P_3}{P_c} - m_{11} \\ \frac{P_4}{P_d} - m_{11} \end{bmatrix}$$

Rewriting the relationship between an arbitrary input Stokes vector and the total output power in terms of transmission then yields [5]:

$$T = \frac{S_{0_{out}}}{S_{0_{in}}} = \frac{m_{11}S_{0_{in}} + m_{12}S_{1_{in}} + m_{13}S_{2_{in}} + m_{14}S_{3_{in}}}{S_{0_{in}}}$$

The extrema of the above equation can be derived as:

$$\begin{aligned} T_{\max} &= m_{11} + \sqrt{m_{12}^2 + m_{13}^2 + m_{14}^2} \\ T_{\min} &= m_{11} - \sqrt{m_{12}^2 + m_{13}^2 + m_{14}^2} \end{aligned}$$

Inserting T_{\max} and T_{\min} in the equation for PDL yields the desired result.

It is obvious that the calculation itself is not difficult but can require programming effort, especially if the PDL must be obtained over wavelength. Then, the linear equation system must be solved for every wavelength point.

PFL Loss - Measurement and Analysis Functions

The PFL provides a set of functions that simplifies the implementation of swept-wavelength loss-measurement solutions. In the following section, these functions are briefly explained.

Insertion Loss

Measuring insertion loss requires a setup as depicted in Figure 2. Similar to the plug&play driver functions, the PFL requires three commands to perform a swept-wavelength multi-channel insertion loss measurement.

- *pfl_prepareMFlambdascan*: This function sets the parameters for swept-wavelength loss measurements, such as: output power, optical output port, wavelength range defined by start and stop wavelength as well as step size, sweep speed, dynamic range and selection of used power meter channels.
- *pfl_executeMFlambdascan*: This function executes the swept-wavelength multi-channel insertion loss measurement.
- *pfl_getMFlambdaScanResult*: This function returns power and wavelength arrays for the chosen channel.

To determine the actual insertion loss of a DUT, two functions are provided by the PFL.

- *pfl_calcLossFromRef*: This function requires data from two power measurements: the reference power and DUT transmitted power. From these values, the actual loss of the DUT is calculated using Equation 1. This function provides the most accurate insertion loss measurements, assuming that the setup's influence on the power measurements was repeatable between the reference and DUT measurement.

² For convenience, a vertical representation of the equation was chosen.

- *pfl_calcLossFromPow*: Here, the insertion loss is calculated by referencing all DUT measurement data to a fixed input power level, for example the laser output power. This power is assumed to be flat over wavelength. However, influences of the setup cannot be calibrated out using this function.

As mentioned, the function calls are similar to the *VXI 816x Plug&Play* driver functions for an insertion loss measurement. The added value of the PFL are the comprehensive analysis functions with which filter parameters such as bandwidth, crosstalk etc. can be obtained.

Polarization Dependent Loss

As mentioned above, a PDL measurement using the Mueller method is nothing other than an insertion loss measurement at four defined input-polarization states. Therefore, the functions that perform an insertion loss measurement are similar to the above, but shall be listed here again for completeness. The calculation of the PDL using the Mueller algorithm is implemented in a separate function. Prior to the measurements, the 8169A polarization controller must be adjusted for maximum transmission.

- *pfl_FindMaxPolPosition*: This function adjusts the polarizer at the input of the 8169A polarization controller so that maximum transmission through the polarizer (and thus the least impact on the overall dynamic range) is obtained. Although the tunable laser source provides linear output polarization, the optical connection in the form of a standard single-mode fiber (SMF) patchcord transforms this polarization into an unknown state incident on the polarizer³. In the worst case, this state of polarization would be orthogonal to the polarizer's transmitting axis, reducing the dynamic range of the entire system by the polarizer's extinction ratio⁴.
- *pfl_prepareMFlambdaScan*: see above.
- *Pfl_executeMFlambdaPolScan*: This function executes a swept-wavelength multi-channel insertion loss measurement at a specific input state of polarization, which is generated by adjusting the wave plates of the 8169A polarization controller to a specific angle, independent of the selected wavelength range. The rotation angle of each wave plate is set relative to the

polarizer angle found for maximum transmission, see Table 1.

	Quarter Waveplate	Half Waveplate
LHP	0°	0°
L +45	0°	+ 22.5°
L -45	0°	- 22.5°
RHC	45°	0

Table 1: Rotation angles of the waveplates for the four states of polarizations as used by the PFL. The angles represent the deviation from the reference angle of the polarizer.

- *pfl_getMFlambdaScanResults*: see above.
- *pfl_calcPDLMueller8169A*: This analysis function calculates the PDL over wavelength according to the Mueller algorithm. The average insertion loss and the maximum and minimum transmission are additional output parameters. The function expects the reference and DUT transmission measurement data over wavelength, at the well defined four states of polarization. All together, eight arrays of power data are required as input. The function corrects any wavelength-dependent error that occurs while generating the four polarization states. This correction enables performing PDL measurements in the L-Band with high accuracy. The error comes from the wavelength dependent retardation of the wave plates in the 8169A polarization controller. The correction is explained below.

As can be seen from the function list above, only a few commands are required to perform a complete PDL Mueller measurement. In comparison using the 816x Plug&Play driver functions, only the loss measurements at the four states could be implemented (with greater effort). Calculation of the PDL from the measured data using the Mueller calculus and any corrections is not included in the function pool of the PnP driver⁵, and needs to be implemented separately. Herein lies the advantage of the PFL.

³ The polarization transformation along a fiber is statistical in nature and unpredictable. It stems from the retarding property of the fiber, based on its birefringence.

⁴ The polarizer extinction ratio (PER) is defined as the ratio of maximum to minimum transmission through the polarizer.

⁵ The 816x Plug and Play driver combines one or more direct I/O commands into one function, providing parameter checking and error handling. The driver offers functions for basic instrument programming and control as well as added value in terms of swept wavelength multi-channel measurements, including stitching routines to extend the dynamic range of a loss measurement.

Analysis

Measuring just the insertion loss or PDL is often not sufficient to characterize a component. To obtain a more complete picture of the component's characteristics, especially for (D)WDM components, further parameters such as bandwidth, channel spacing, center wavelength and so on are desired. The PFL offers a set of functions to analyze spectral insertion loss measurements. The diversity in definitions of such parameters forces the PFL functions to calculate these parameters most flexibly. One good example is bandwidth definition of a passband filter, which can be required for a large range of loss values, such as 1dB, 3 dB and so on. As the PFL provides a powerful and flexible set of analysis tools, this is covered in a separate application note in more detail.

Real Time Sweep

Fast update of the spectral transfer function of a filter is an essential enhancement that the PFL provides to the Lightwave Measurement System 816x.

The tunable laser source is continuously sweeping over the specified wavelength range, taking power measurements at a selected wavelength resolution. The sweep speed can be chosen according to the required wavelength resolution. The relation between sweep speed and wavelength resolution is determined by the power meter sampling frequency of 10kHz. A common solution to perform such real-time measurements is to use an optical spectrum analyzer. However, an OSA cannot provide the resolution of a tunable laser source, necessary to characterize most advanced narrowband filters. Therefore, the higher wavelength resolution of a TLS, combined with the capability of fast spectral updates represents a powerful solution for automated alignment and test of filters. An example of thin film filter alignment is described later.

Another advantage of the TLS real-time sweep solution is its multichannel capability, which allows the serving of several alignment stations simultaneously⁶.

Four PFL commands are necessary to incorporate the fast sweep function:

- *pfl_prepareFastSweep*: This function is used to set standard sweep parameters, such as wavelength range, step size, TLS optical output, output power and the number of used channels. In addition, the range of the

⁶ For such a setup, the laser output signal is distributed to N alignment stations, each of which incorporates power sensors or optical heads in transmission and/or reflection.

power meters can be set. This is especially useful, as the fast update function does not do multiple sweeps to enlarge the dynamic range. Depending on the power incident on the DUT, the power meter range can be selected to provide the greatest dynamic⁷ range.

- *pfl_executeFastSweep*: Surrounded by a program loop, this function performs the wavelength sweep.
- *pfl_getFastSweepResults*: This function receives the measurement data from the test system. This function is also located in the program loop.
- *pfl_closeFastSweep*: This function quits the real-time mode of the measurement system.

Table summarizes approximate update rates⁸ (in seconds) depending on measurement parameters.

	# Channels	1	2	4	8
Range	Step Size				
2nm	10pm	0.80	0.89	1.24	2.28
10nm	10pm	1.05	1.20	1.63	2.53
50nm	10pm	3.38	3.62	3.67	4.82
100nm	10pm	6.67	7.08	7.09	7.68
100nm	100pm	5.35	5.35	5.33	5.34

Table 2: Update rates (in seconds) in Real Time Mode, depending on the wavelength range, step size and power meter channels.

Accuracy Enhancement

The PFL provides not only a comprehensive set of measurement and analysis functions, it is also a strong accuracy enhancement to the Lightwave Measurement System 816x. In certain demanding cases the PFL facilitates implementing the full accuracy capability of the system. The main features of the PFL are discussed in this section.

Adaption of Power Meter Averaging Times

Different devices exhibit different spectral characteristics. The measurement of a component's loss characteristic requires different wavelength resolutions according to the nature of the device. A narrowband filter for example is best examined with a high resolution, to accurately capture step

⁷ As an example, consider an incident power of -12dBm at the power detector. The best power range to choose is the -10dBm range, providing around 35dB of dynamic range.

⁸ The update rates are only approximate numbers. Numbers may change under different conditions. For these measurements, all instruments utilized firmware Rev. 3.0.

filter slopes or any impairment of its functionality. However, for broadband filters with a smooth and slowly-changing filter response over wavelength, wavelength resolution can be lower.

Related to the wavelength resolution are the sweep speed and power meter averaging times. For low resolutions, like a large wavelength step size, the power meter averaging time and the sweep speed can be optimized to lower noise effects by longer averaging and to reduce measurement cycle time. The immediate question is whether this can cause the obtained filter response to be smeared out by averaging too long. This is avoidable if the wavelength resolution is always adapted to the nature of the filter. A narrowband filter is always measured with a high wavelength resolution (like a small wavelength step size) and thus the averaging time is small. Fast changes in power can thus be captured correctly. On the other hand, for broadband devices that exhibit only slow changes in transmission over wavelength the step size can be increased, and longer averaging times can be applied. The relation between sweep speed, step size and averaging time is 10kHz maximum, or 40kHz for the fast power sensors, 81636B and 81637B. This allows for minimum averaging times of 100 μ s or 25 μ s, respectively, used to determine the power meter sampling frequency. The PFL automatically selects appropriate power meter averaging times according to the selected wavelength resolution and sweep speed in a swept wavelength scan, as shown in Table 3.

	100 μ s	1ms	5ms	10ms
40nm/s	4 μ m	40 μ m	200 μ m	400 μ m
10nm/s	1 μ m	10 μ m	50 μ m	100 μ m
5nm/s	0.5 μ m	5 μ m	25 μ m	50 μ m

Table 3 :The power meter averaging time is automatically set according to the chosen sweep speed and wavelength resolution.

The PFL can also automatically select the appropriate sweep speed. Table 4 shows the relation between the chosen wavelength resolution and the sweep speed and averaging time set automatically by the PFL.

Resolution	Sweep Speed	Averaging Time
0.5 μ m	5nm/s	100 μ s
1 μ m	10nm/s	100 μ s
2 μ m	10nm/s	200 μ s
5 μ m	10nm/s	500 μ s
10 μ m	10nm/s	1ms
20 μ m	10nm/s	2ms
50 μ m	10nm/s	5ms

Table 4 :Sweep Speed and Averaging Times set according to the selected wavelength resolution in AUTO sweep speed mode.

The advantage is that the user does not need to manually determine the appropriate averaging time.

Correction of the Wave Plate Retardation Error

For PDL measurements using the Mueller method, a polarization controller such as the 8169A is introduced into the measurement setup. The polarization controller 8169A is capable of deterministically synthesizing polarization states, such as the four required states for the Mueller algorithm. The polarization controller 8169A consists of a polarizer, a quarter- and a half-wave retarder, as shown in Figure 6. The polarizer generates linearly polarized light, which is then transformed through specific rotation of the retarders to any other output polarization.

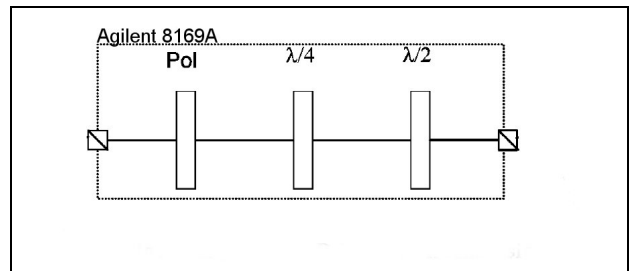

Figure 6: Optical setup of 8169A polarization controller.

However, the retarder wave plates only act as true quarter- and half-wave retarders around their design wavelength. This is a fundamental limitation of all waveplates, and hence for all polarization controllers that utilize waveplates.

The design wavelength for the retarder plates within the 8169A polarization controller is 1540nm. For wavelengths far away from this design wavelength⁹, a retardation error is introduced, as depicted in the example of linear horizontally

⁹ The considered wavelength range is 1510-1630nm. The S-band is excluded from this discussion.

olarized light¹⁰ in Figure 7. Ideally, the Stokes vector for such polarization would be (1, 1, 0, 0). Obviously, this is only true around the design wavelength of the retarder plates, but not for wavelengths far away like in the L-Band.

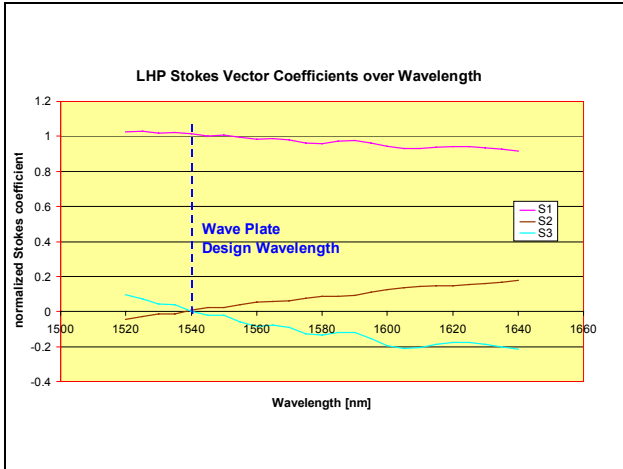

Figure 7: Variation of the LHP Stokes vector over wavelength.

The error related to the shift in polarization could be compensated by slightly changing the rotation angles of the wave plates at different wavelengths. However, in swept-wavelength PDL measurements such a correction is impractical because of the fast tuning speed.

The PFL corrects for the wave-plate retardation errors by accounting for the real states of polarization that have been applied to the DUT. In this way, the correct Stokes vectors generated by the polarization controller are taken into the PDL calculation.

This is implemented within the PDL calculation function of the PFL, *pfl_calcPDLMueller8169*.

The effect of the implemented correction is shown in Figure 8. A tilted glass plate served as the DUT. As can be calculated¹¹, the PDL of a tilted glass plate is very constant over wavelength. However, the PDL curve obtained by applying the ideal Stokes vectors to the Mueller calculus shows a slight tilt. This effect becomes even more apparent for higher PDL values.

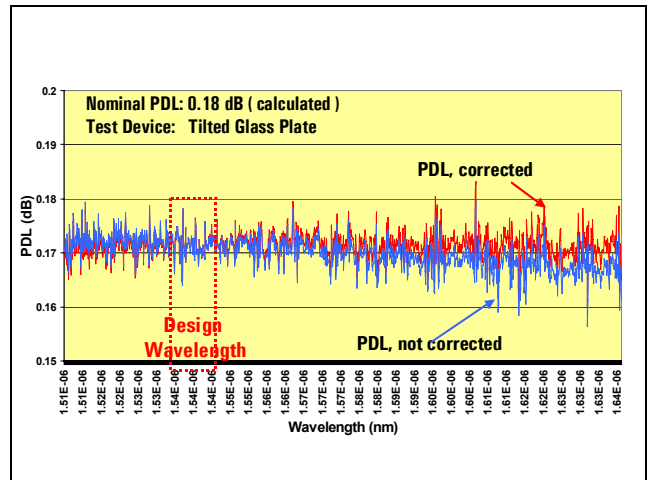

Figure 8: Comparison of PDL measurements with and without correction.

In contrast, using the real Stokes vectors, as done in the PFL, shows a significant improvement. The PDL is constant over wavelength, as expected.

Wavelength Accuracy

Continuous Real-Time Wavelength Measurement

The Agilent tunable laser sources contain a built-in real-time wavelength meter. The optical arrangement of the wavelength meter is depicted in Figure 9.

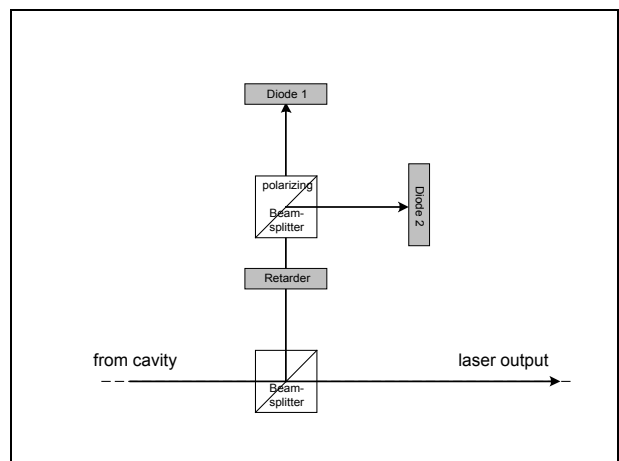

Figure 9: Setup of real-time wavelength meter, integrated into Agilent's tunable laser sources.

A fraction of the laser light is coupled out of the main laser beam. As a wavelength-selective element, a combination of a retarder plate and a polarizing beamsplitter is used [6]. The

¹⁰ The measurement of the Stokes vector has been done using an Agilent 8509B polarization analyzer. The measurement is intended to show a trend for wavelengths far away from the design wavelength of the retarders. The data is not meant to represent absolutely accurate results.

¹¹ The calculation is based on the Fresnel equations.

two principal axes (fast and slow) of the retarder can be seen as two slightly detuned etalons. The polarizing beamsplitter divides the output signals of the two etalons and directs the signals onto two diodes. The relation of the two measured powers gives a sensitive indication for a change in wavelength. After calibration, this setup can provide continuous wavelength information in real-time. This internal wavelength meter enables high wavelength accuracy in swept-wavelength measurements without external wavelength calibration. As an example, the measured and specified minimum of one Acetylene absorption peak are compared, as shown in Figure 10. The measurement shows excellent agreement with the specification.

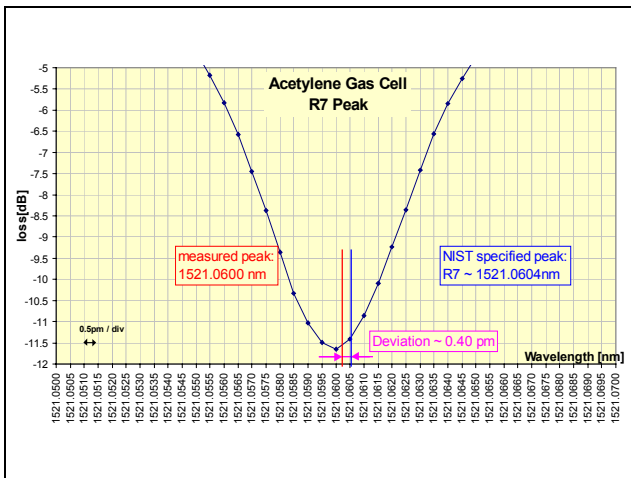

Figure 10: A measurement of the acetylene absorption peak R7 is shown. The deviation of the measured peak and NIST specification is only 0.4pm.

Wavelength Calibration

To further increase the wavelength accuracy and repeatability, the PFL provides a

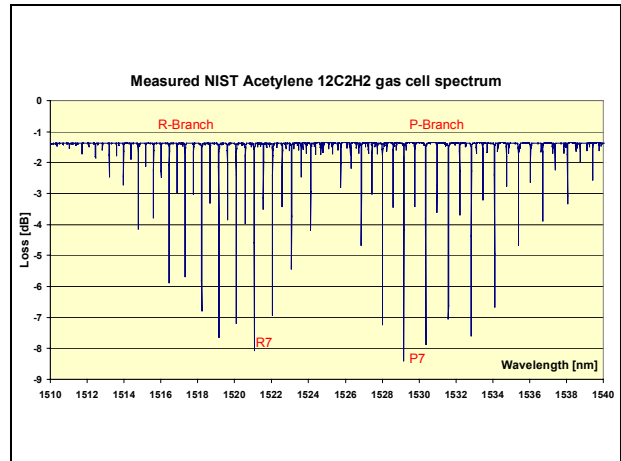

Figure 11: Typical spectrum of acetylene. The exact knowledge of the peaks provides a tool to calibrate the wavelength axis in swept measurements.

function to perform an additional calibration step, using a standard absorption gas cell such as an Acetylene gas cell, as shown in Figure 11. This calibration step is not necessary for most demanding measurement applications due to the high accuracy of the built-in wavelength meter of a tunable laser source. Only in rare cases does such an additional wavelength calibration prove to be necessary.

The correction is based on a comparison of the measured and the NIST-specified wavelength location of absorption gas cell peaks. The PFL allows selection among some common gas absorption cells, such as C¹²- or C¹³-acetylene, and cyanide gas cell. In fact, the PFL function *pfl_measureWavelengthOffset* determines the mean deviation between the measured and specified peak location and returns this value as the absolute wavelength error.

The absolute error describes the overall deviation of all measured wavelength points with respect to the real location of all wavelength points. It can be considered as an entire shift of the measurement wavelength axis to longer or shorter wavelengths. In contrast, the relative error describes the deviation of the measured wavelength points from the absolute error. It describes the wavelength error of the wavelength points with respect to each other.

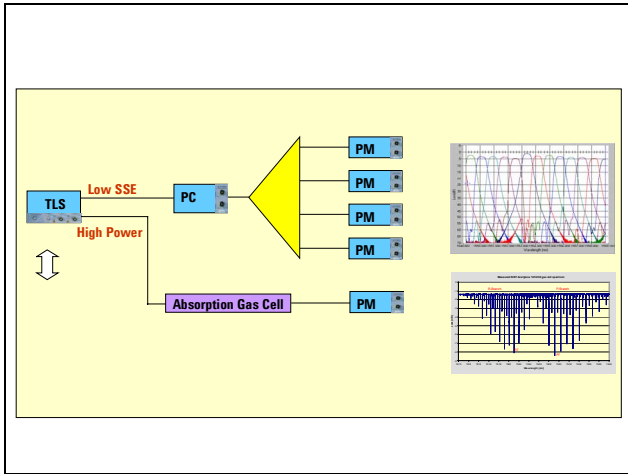

Figure 12: Measurement setup that uses the high power optical output of the TLS for wavelength calibration measurements by means of an absorption gas cell.

To minimize the wavelength error, a gas absorption cell as wavelength reference can be included in the measurement setup. Then, the gas cell can be connected to the tunable laser source and a power meter, as shown in Figure 12. The setup enables measurement of the DUT and a simultaneous wavelength reference measurement. The improvement in absolute wavelength accuracy from such a calibration is shown in Figure 13.

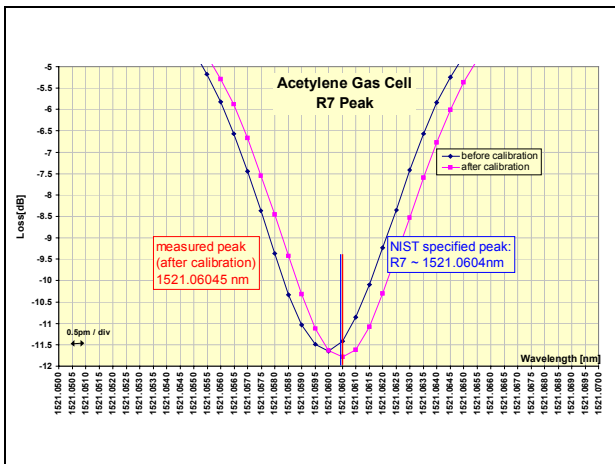

Figure 13: Measurement of the Acetylene absorption peak R7, before and after calibration.

Correction of Delay and Distortion Effects in Swept Wavelength Systems

In swept-wavelength measurements, many (mostly well-known) sources of inaccuracy exist. One possible source of error is directly related to the tuning speed of a tunable laser source. This section describes the limitations of dynamic systems and outlines system parameters that influence the measurement quality. It should be observed at this point that for most swept-wavelength applications, the dynamic limitations of test systems do not have a great impact on the measurement accuracy, compared to other possible sources of inaccuracies. However, as the PFL takes care of effects that may occur, it is worthwhile to describe this here.

Swept measurements offer short test cycles, thus being very attractive for manufacturing test applications. However, accuracy and tuning speed are directly related. In practically every measurement system, the measurements need to be “conditioned” to achieve higher accuracy. Such conditioning includes suppression of noise, especially if high dynamic ranges are measured. It also includes removing signals above the Nyquist frequency limit to ensure anti-aliasing. Both forms of signal conditioning are achieved through filtering, which is depicted in Figure 14 for an ideal band-pass filter with square-wave signal. Typically, the measurement signal is overlaid by some noise effects.

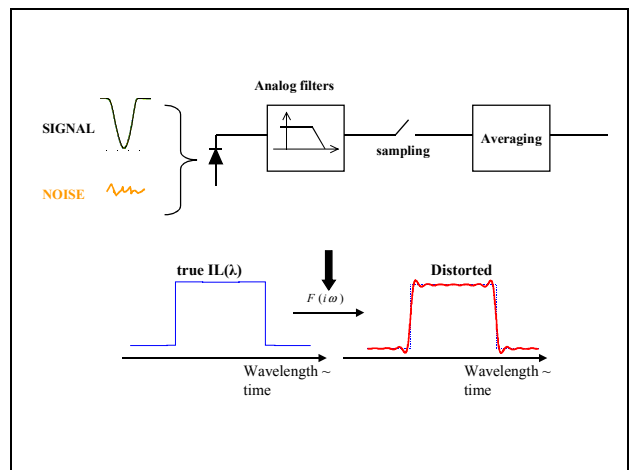

Figure 14: Filtering in measurement systems: Anti-Aliasing and noise reduction.

However, filtering causes related errors, which may be classified as:

- Signal Delay, which is apparent as a wavelength offset. This error depends on the tuning sweep and the measurement setup itself.
- Signal Distortion, which depends in addition to sweep speed and measurement setup on the spectral characteristics of a DUT.

Such delay and distortion effects are depicted in Figure 15, where a sharp gas cell peak¹² was measured at various sweep speeds in a low power range (< 50dBm) [7]. The measurements show increasing wavelength shifts and distortions of the filter response with higher sweep speeds, (in such a low power range), resulting from the described delay and distortion effects. It must however be clearly pointed out here that in higher power ranges, only delay effects are contributing, which may be apparent as very small wavelength shifts on the order of 1pm.

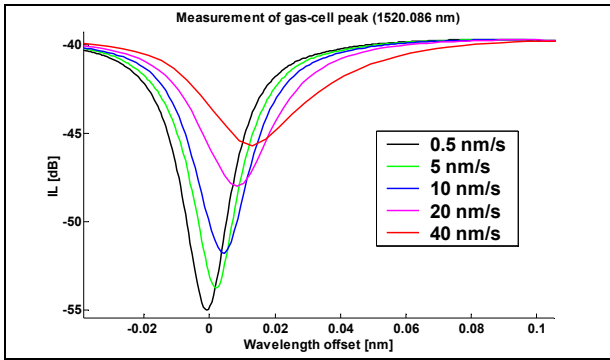

Figure 15: Signal delay and distortion effects, caused by filtering of measurements.

To avoid such errors, one possible solution would be to choose an appropriate measurement speed, naturally a slow one. However, this contradicts the goal of fast measurement cycles, and has a negative influence on the manufacturing throughput.

Another possibility is data post-processing. One of the major side effects of filters is their phase delay, which delay and in some cases even distort the signal, but do not contribute to any noise suppression.

The PFL contains such data post-processing algorithms, which are used in standard swept-wavelength measurement functions. The result of these corrections is significant. Comparing the gas cell peak, as shown in Figure 16, with and without post-processing¹³, shows obvious improvements. The measurement accuracy is now almost independent of the

sweep speed, reinforcing the biggest objective of measurement systems: *Measure it right and measure it fast!*

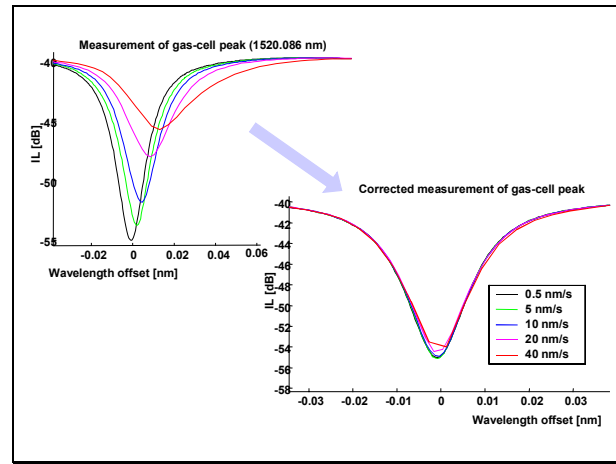

Figure 16: Absorption peak of a gas cell measured at various sweep speeds, with and without correction for filtering side effects.

It has to mentioned at this point, that an absorption peak of a gas cell presents a much greater challenge to measurement systems than today's optical filters. The FWHM of such an absorption peak is on the order of 35pm. Nevertheless, such a peak can be used as an indication of what challenges measurement systems will face with tomorrow's components, when channel spacing (and therefore, channel bandwidth) decrease to values below 25GHz.

Use Cases – Examples

The PFL is designed to simplify the integration of test solutions, shorten test development time significantly and enhance the accuracy of Agilent's Lightwave Measurement System 816x. With the functionality of the library, many different applications can be addressed easier, some of which will be briefly explained in this section.

¹²In this particular measurement, 32 dB of attenuation have been inserted to anticipate problems in the characterization of the component's stop bands (40-45 dB IL).

¹³Please note the different scales in Figure.

Thin Film Filter Alignment

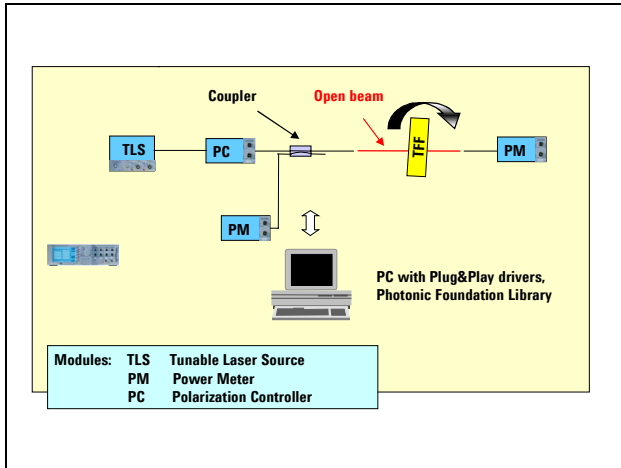

Figure 17: Typical setup of a thin film filter alignment and test station.

Thin film filters are used for a variety of optical components, such as multiplexers/demultiplexers or WDM filters. The quality of the final device depends on the quality of the filter alignment to the input and output fibers as well as on the spectral transmission properties of the filter, which are verified in an incoming inspection test. High throughput is achieved by automating the positioning of the test devices. The automated alignment requires optical feedback in form of real-time measurements of the spectral transmission and reflection properties. Fast data acquisition and analysis are mandatory for high throughput.

Thin film filters are small glass cubes that are coated with numerous dielectric layers of different refractive indices. The structure of the dielectric layer determines which wavelengths are reflected or transmitted by the interference of optical waves within the layer.

Whether in an alignment application or a spectral filter response measurement, a typical setup requires the adjustment of the filter to the incident lightwave. The filter is positioned into an open-beam arrangement, as shown in Figure 17. The alignment can be monitored by reading out the reflection at an off-center wavelength or by capturing the spectral filter response. For orthogonal alignment, the filter is adjusted in such a manner that the reflection is maximized or the center wavelength of the notch is minimized.

The alignment procedure requires an optical feedback for position verification. Fast updates of the spectral filter response or reflection properties during the adjustment process are mandatory. Here, the fast sweep mode provided by the Photonic Foundation Library in conjunction with a

tunable laser source and optical power sensor or head provides real time updates with the wavelength accuracy and resolution required for WDM components, thus representing an ideal solution for automated filter alignment systems. Increased throughput, reduced development effort and simplified integration into the automated system are the key contributions to the test cost reduction.

Monitoring Fiber Bragg Grating Writing Process

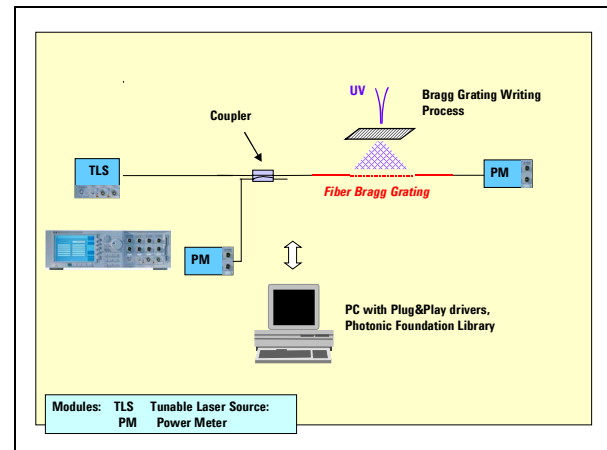

Figure 18: Typical measurement setup to control a fiber Bragg grating during the writing process.

Fiber Bragg gratings are used for a variety of optical components, such as add-drop modules, gain flattening filters, WDM filters or dispersion compensators. The process of writing the Bragg grating into a fiber is critical for the functionality of the final component. Therefore, it is desirable to monitor the spectral transmission properties of the fiber grating during the writing process in a so-called in-process test. A typical example of such an in-process test is the measurement of the optical characteristics of Fiber Bragg Gratings during or after the Bragg grating writing process, Figure 18. The solution provides fast feedback for adaptive processes and shows how to achieve high manufacturing throughput by fast lambda update of the tunable laser source, operated in a real-time mode.

Throughput can be optimized by performing spectral transmission tests during the production process, hence reducing the number of required test steps afterwards. The test solution demands real-time spectral loss measurements and provides feedback of the process quality

Multiplexer / Demultiplexer Test

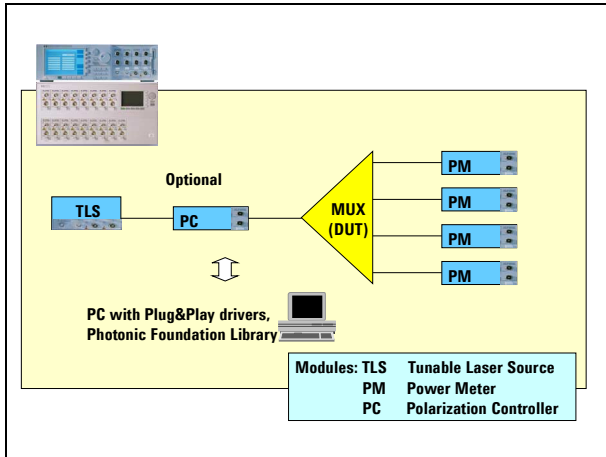

Figure 19: Optical test solution for multi-channel devices, such as multiplexers and demultiplexers.

Multiplexers/Demultiplexers are among the most demanding components for testing, because they combine high port counts with high dynamic range and narrow channel spacing, all of which set special requirements on test solutions. The test of Mux / DeMux as depicted in Figure 19 relies on high measurement accuracy because test results are usually provided together with the device, and specifications are based on or confirmed with the measurement results. Swept-wavelength, multichannel loss measurements contribute to a significant reduction of test cycle times while providing a comprehensive set of measurement and analysis parameters such as insertion loss, PDL and return loss.

Agilent's Photonic Foundation Library contains functions to perform swept-wavelength insertion loss and Mueller method PDL measurements and to flexibly analyze spectral loss measurements for specific channel characteristics, such as center wavelength, ndB bandwidth, cross-talk etc.

Agilent Technologies' Test and Measurement Support, Services, and Assistance

Agilent Technologies aims to maximize the value you receive, while minimizing your risk and problems. We strive to ensure that you get the test and measurement capabilities you paid for and obtain the support you need. Our extensive support resources and services can help you choose the right Agilent products for your applications and apply them successfully. Every instrument and system we sell has a global warranty. Support is available for at least five years beyond the production life of the product. Two concepts underlie Agilent's overall support policy: "Our Promise" and "Your Advantage."

Our Promise

Our Promise means your Agilent test and measurement equipment will meet its advertised performance and functionality. When you are choosing new equipment, we will help you with product information, including realistic performance specifications and practical recommendations from experienced test engineers. When you use Agilent equipment, we can verify that it works properly, help with product operation, and provide basic measurement assistance for the use of specified capabilities, at no extra cost upon request. Many self-help tools are available.

Your Advantage

Your Advantage means that Agilent offers a wide range of additional expert test and measurement services, which you can purchase according to your unique technical and business needs. Solve problems efficiently and gain a competitive edge by contracting with us for calibration, extra-cost upgrades, out-of-warranty repairs, and on-site education and training, as well as design, system integration, project management, and other professional engineering services. Experienced Agilent engineers and technicians worldwide can help you maximize your productivity, optimize the return on investment of your Agilent instruments and systems, and obtain dependable measurement accuracy for the life of those products.

By internet, phone, or fax, get assistance with all your test & measurement needs

Online assistance:

www.agilent.com/comms/lightwave

Phone or Fax
United States:
(tel) 1 800 452 4844

Canada:
(tel) 1 877 894 4414
(fax) (905) 206 4120

Europe:
(tel) (31 20) 547 2323
(fax) (31 20) 547 2390

Japan:
(tel) (81) 426 56 7832
(fax) (81) 426 56 7840

Latin America:
(tel) (305) 269 7500
(fax) (305) 269 7599

Australia:
(fax) (61 3) 9210 5947

New Zealand:
(tel) 0 800 738 378
(fax) 64 4 495 8950

Asia Pacific:
(tel) (852) 3197 7777
(fax) (852) 2506 9284

Product specifications and descriptions in this document subject to change without notice.

Copyright © 2001 Agilent Technologies
March, 21 2002
5988-3622EN

Related Agilent Literature:

- [1] Andreas Gerster, Gunnar Stolze: "Cost-of-Test considerations for optical component test", *Fibre Systems*, to be published.
- [2] Leckel, E., Sang, J., Wagemann, U. and Müller, E.: "Impact of source spontaneous emission (SSE) on the measurement of DWDM components", paper WB-4, *Optical Fiber Conference*, Baltimore, 2000.
- [3] Application Note "State of the Art characterization of optical components for DWDM applications", PN 5980-1454E, Agilent Technologies, 2000.
- [4] Application note "Polarization Dependent Loss Measurements of passive optical components", PN 5988 - 1232EN, Agilent Technologies 2000.
- [5] Application note "PDL Measurements using the 8169A polarization controller", PN 5964-9937E, Agilent Technologies 2000.
- [6] Müller, E., Rück, C., Born, T., Wagemann, U., Leckel, E.: "Fast and accurate determination of a tunable laser wavelength and its application to DWDM components", paper WB-2, *Optical Fiber Conference*, Baltimore, 2000.
- [7] Bertogalli, V., Wagemann, E.U., Müller, E., Leckel, E.: "Testing passive DWDM components: Uncertainties in swept-wavelength measurement systems", *Optical Fiber Conference*, Anaheim, 2001



Agilent Technologies