

# Agilent PSA Performance Spectrum Analyzer Series

## Optimizing Dynamic Range for Distortion Measurements

### Product Note

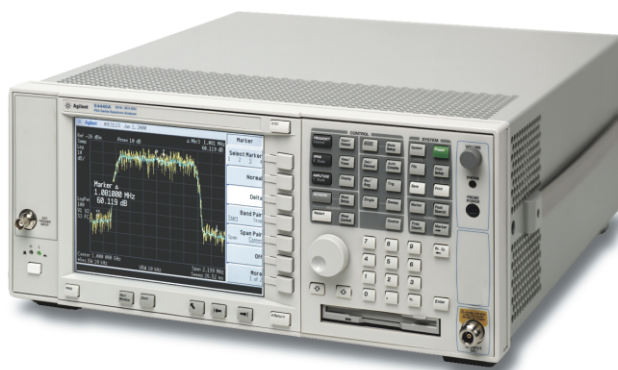

Its wide dynamic range makes the spectrum analyzer the test instrument of choice for measuring harmonic distortion, intermodulation distortion, adjacent channel power ratio, spurious-free dynamic range, gain compression, etc. Distortion measurements such as these are bounded on one side by the noise floor of the spectrum analyzer and on the other side by the signal power strength at which the spectrum analyzer's internally generated distortion masks the distortion being measured. The simultaneous low noise floor and low internally generated distortion products uniquely qualify the spectrum analyzer for making distortion measurements.

Having wide dynamic range and accessing this dynamic range are two different things. Unless the user is given enough information on how to optimize the spectrum analyzer to make distortion measurements, its dynamic range performance cannot fully be exploited. Many distortion measurements are very straightforward: measure the fundamental tone power, measure the distortion product power, and compute the difference. Problems arise when the device under test has distortion product

levels that approach the internally generated distortion product levels of the spectrum analyzer. Further complications arise when trying to maximize speed and minimize measurement uncertainty. In these cases more care in the measurement technique is required.

The search for information on making distortion measurements begins with the spectrum analyzer data sheet. The data sheet is most useful for comparing one spectrum analyzer against another in its dynamic range capability and the relevant measurement uncertainties in the distortion measurement. What the data sheet fails to convey is how to configure the spectrum analyzer to achieve the specified dynamic range performance.

Primers are another source of information. Two excellent references are [1] and [2] listed on page 39 of this document. Primers such as these provide the necessary fundamental knowledge for making distortion measurements. Yet, primers treat spectrum analyzers as a general class of test instrumentation. In order to

make truly demanding distortion measurements accurately or less demanding measurements more quickly, the user needs product specific information.

This product note bridges the gap between primers and data sheets, focusing on distortion measurements using the Agilent Technologies performance spectrum analyzer (PSA) series (model E4440A). Part I is a self-contained section for making the less demanding distortion measurement quickly using the auto-coupled settings found in the PSA. Part II guides the user in setting the appropriate power at the input mixer in order to maximize the dynamic range for carrier wave or continuous wave (CW) measurements. Part III explains the measurement of distortion measurements on digitally modulated signals. Part IV details some of the internal architecture of the PSA as it relates to distortion measurements. Finally, Part V describes some measurement techniques, both internal and external to the PSA, that yield more accuracy in certain kinds of distortion measurements.



**Agilent Technologies**

Innovating the HP Way

## Table of Contents

<b>Part I: Distortion Measurement Examples</b>	<b>4</b>
Harmonic Distortion	4
Intermodulation Distortion	6
Small Signal Desensitization	9
Spectral Regrowth of a Digitally Modulated Signal	11
<b>Part II: Mixer Level Optimization</b>	<b>12</b>
Signal-to-Noise versus Mixer Level	12
Signal-to-Noise with Excess Noise	15
Signal-to-Distortion versus Mixer Level	15
The Dynamic Range Chart	17
Adding Phase Noise to the Dynamic Range Chart	18
Noise Adding to the Distortion Product	19
SA Distortion Adding to DUT Distortion	21
<b>Part III: Distortion Measurements on Digitally Modulated Signals</b>	<b>23</b>
Choice of Averaging Scale and Display Detector	23
Maximizing Spectrum Analyzer Dynamic Range	24
Signal-to-Noise of Digitally Modulated Signals	24
Spectral Regrowth Due to Spectrum Analyzer Intermodulation Distortion	25
Phase Noise Contribution	27
Dynamic Range Chart for Digitally Modulated Signals	28
Measurement Error Due to SA Spectral Regrowth Adding to DUT Spectral Regrowth	30
<b>Part IV: PSA Architectural Effects on Distortion Measurements</b>	<b>31</b>
Input Attenuator Resolution	31
Internal Filtering	32
Internal Preamplifier	33
<b>Part V: Enhancing Distortion Measurements</b>	<b>34</b>
Reducing Source Intermodulation Distortion	34
Effects of Harmonics on Intermodulation Distortion	35
Noise Subtraction Techniques	36
<b>Conclusions</b>	<b>38</b>
<b>Glossary of Terms</b>	<b>38</b>
<b>References</b>	<b>39</b>

## About the Agilent PSA Performance Spectrum Analyzer Series

The Agilent PSA series are high-performance radio frequency (RF) and microwave spectrum analyzers that offer an exceptional combination of dynamic range, accuracy and measurement speed. The PSA series deliver the highest level of measurement performance available in Agilent Technologies' spectrum analyzers. An all-digital IF section includes fast Fourier transform (FFT) analysis and a digital implementation of a swept IF. The digital IF and innovative analog design provide much higher measurement accuracy and improved dynamic range compared to traditional spectrum analyzers. This performance is combined with measurement speed typically 2 to 50 times faster than spectrum analyzers using analog IF filters.

The PSA series complement Agilent's other spectrum analyzers such as the ESA series, a family of mid-level analyzers that cover a variety of RF and microwave frequency ranges while offering a great combination of features, performance and value.

### Specifications:

<b>Frequency coverage</b>	3 Hz to 26.5 GHz
<b>DANL</b>	-153 dBm (10 MHz to 3 GHz)
<b>Absolute accuracy</b>	±0.27 dB (50 MHz)
<b>Frequency response</b>	±0.40 dB (3 Hz to 3 GHz)
<b>Display scale fidelity</b>	±0.07 dB total (below -20 dBm)
<b>TOI</b> (mixer level -30 dBm)	+16 dBm (400 MHz to 2 GHz) +17 dBm (2–2.7 GHz) +16 dBm (2.7–3 GHz)
<b>Noise sidebands</b> (10 kHz offset)	-113 dBc/Hz (CF = 1 GHz)
<b>1 dB gain compression</b>	+3 dBm (200 MHz to 6.6 GHz)
<b>Attenuator</b>	0–70 dB in 2 dB steps

## Part I: Distortion Measurement Examples

In this first part we offer quick methods of making some common distortion measurements using a PSA series spectrum analyzer (model E4440A). Measurements in this section emphasize the auto-coupled features of the PSA series that serve the occasional user or the user who must quickly make distortion measurements and just does not have the time to learn the intricacies of the analyzer. Techniques outlined in this section purposely place the analyzer in states such that the measurement is noise-limited rather than distortion-limited. The user does not need to worry if the distortion generated within the analyzer is interfering with the distortion generated by the device under test (DUT).

The measurement procedures outlined in this section place the spectrum analyzer in narrow spans where only the fundamental tone or only the distortion product is displayed at any given time. This technique is in opposition to the more intuitive approach of using a span wide enough to view the fundamental tones and the distortion products in one sweep. In order to increase the signal-to-noise-ratio of the spectrum analyzer, the resolution bandwidth (RBW) filter setting must be reduced. Furthermore, to reduce the variance of the measured distortion products that appear close to the noise floor, the video bandwidth (VBW) filter setting must be reduced. The combination of wide span,

### Notation used in this section

<u>underlined commands</u>	=	hardkeys
non-underlined commands	=	softkeys
: (colon)	=	separator between key sequences
< numeric value >	=	user entered numeric value
↑, ↓	=	the up and down arrow hardkeys

**Figure 1-1**  
**Harmonic Distortion Measurement Setup**

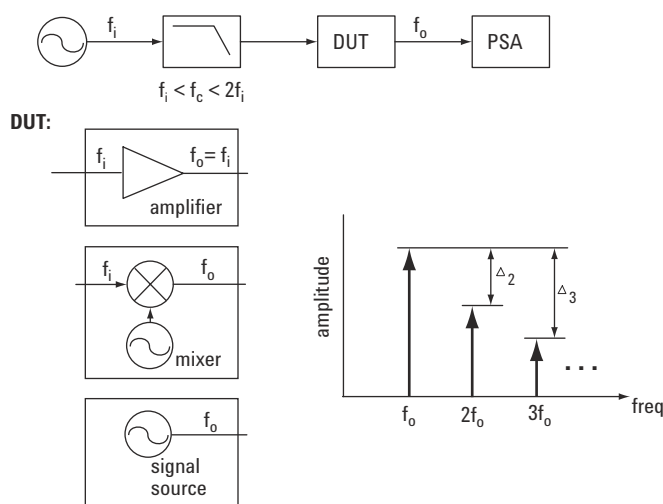

narrow RBW and narrow VBW, in general, increases the sweep time. By reducing the span, more dynamic range is available without sacrificing sweep time.

For many measurements, the techniques described in this section are more than adequate. If the distortion product is measurable, then the measurement procedure is adequate. If only noise is discernible when measuring the distortion product, then techniques in Parts II, III, IV and V must be considered to increase the dynamic range of the analyzer.

### Harmonic Distortion

Harmonic distortion measurements on a CW tone are the most straightforward of the distortion measurements. The method outlined here allows measurement of harmonics as low as -85 dBc for fundamental frequencies below 1.6 GHz and as low as -110 dBc for fundamental frequencies above 1.6 GHz.

The mixer level (mixer level is defined as the power at the RF input port minus the nominal input attenuation value) of the analyzer is set such that internally generated harmonic distortion products are at least 18 dB below the harmonic distortion of the DUT. This guarantees that the distortion measurement uncertainty due to internal distortion combining with DUT distortion is less than 1 dB.

### Measurement Setup:

The test setup for making harmonic measurements is shown in Figure 1–1.

The DUT is represented as a two-port device, which most commonly is an amplifier. For a three-port mixer, the local oscillator (LO) source is included in the model of the DUT.

In this case the output frequency,  $f_o$ , is a frequency-translated version of the input frequency,  $f_i$ . One can also use this procedure to measure the harmonics of the signal source itself. For two- or three-port devices it may be necessary to include a filter between the signal source and the DUT in order ensure the measured harmonics are due to the DUT and not the signal source.

First, tune the signal source to the desired fundamental frequency,  $f_o$ . If the DUT is a mixer, then tune the source to an input frequency of  $f_i$  and tune the LO source to a frequency appropriate to output a fundamental frequency of  $f_o$  from the DUT. For best results, the frequency references of all the sources and the PSA series analyzer should be locked together where applicable.

---

### Setup PSA Series Analyzer:

**Auto Couple**                      Couples RBW filter, VBW filter, Span and Sweep time.  
  Couples Reference Level and Input Attenuator.

**AMPLITUDE:** More: More: Max Mxr Lvl: < Mixer Level Value > : dBm  
  Mixer Level Value =    / -60 dBm for  $f_o < 1.6$  GHz  
  \ -30 dBm for  $f_o \geq 1.6$  GHz

**BW / Avg:** VBW/RBW: < .1 >  
  Couples the VBW filter and the RBW filter with a bandwidth ratio of 1:10.

---

### Tune to the Fundamental Tone:

**FREQUENCY:** Center Freq: <  $f_o$  >: GHz, MHz, kHz or Hz.  
   $f_o$  is the fundamental frequency at the output of the DUT.

**SPAN:** < 1 > : MHz

**AMPLITUDE:** Ref Level: < Reference Level Value > : dBm  
  Sets Reference Level Value to be higher than the DUT's fundamental tone output power.

**Peak Search**                      Positions marker at the peak of the fundamental tone.

At this point, the source amplitude can be adjusted in order to set the desired DUT output power level.

**Marker →:** Mkr → Ref Lvl  
  Brings displayed fundamental amplitude to the top line of the display graticule to optimize display range.

**Marker →:** Mkr → CF Step  
  Center Frequency step size is set to fundamental frequency.

**Marker:** Delta                      Activates the Delta Marker.

---

### Tune to the 2nd Harmonic:

**FREQUENCY:** ↑                      Tune to the 2nd harmonic frequency

**SPAN:** ↓ : ↓ :↓, etc.                      Reducing the frequency span automatically reduces the RBW value, which in turn reduces the displayed noise.

Span down until the distortion product is at least 5 dB above the noise floor. If the noise floor falls below the bottom of the display then follow this procedure:

**AMPLITUDE:** Attenuation: Attenuation  
  'Man' should be underlined. This de-couples the input attenuator from the reference level.

**AMPLITUDE:** Ref Level: ↓ :↓, etc.  
  Maximum power at the mixer is not altered by changing the Reference Level setting.

For distortion products close to the noise floor, the variance of the signal amplitude can be reduced by lowering the VBW value.

**Bw / Avg:** Video BW: ↓ :↓, etc.

**Peak Search**                      Positions delta marker at peak of the distortion product

The marker delta amplitude value is the 2nd harmonic power relative to the fundamental tone power.

---

### Compute Output SHI (Second Harmonic Intercept) Power Level:

$SHI [dBm] = DUT \text{ Output Power } [dBm] + \Delta_2$

DUT Output Power is the reference level value read from the display minus any loss between the DUT and the input of the PSA series analyzer.  $\Delta_2$  is the negative of the marker delta amplitude value;  $\Delta_2$  is a positive value.

For 3rd, 4th, etc. Harmonic, press **FREQUENCY:** ↑ to tune to each harmonic frequency and record the marker delta amplitude value.

Intercept points are computed using:

$Intercept \text{ Point } [dBm] = DUT \text{ Output Power} + \Delta_i / (i - 1);$   
where i is the order of the harmonic.

## Intermodulation Distortion

Anytime multiple tones are present at the input of any nonlinear device, these tones will mix together, creating distortion products. This phenomenon is known as intermodulation. Amplifiers, mixers and spectrum analyzer front ends are examples of nonlinear devices prone to intermodulation distortion (IMD). Figure 1-2 depicts *some* of the intermodulation products generated when two tones at frequencies  $f_1$  and  $f_2$  are presented to the input of a nonlinear device.

The IMD products falling closest to the fundamental tones, at frequencies  $2f_1-f_2$  and  $2f_2-f_1$ , present the most trouble due to the impracticality of removing these with filtering. These two closest distortion products follow a third order characteristic—their power levels increase by a factor of three when measured on a logarithmic display scale in relationship to the increase in the two fundamental tone power levels. The third order IMD traditionally has been the benchmark distortion figure of merit for mixers and amplifiers. The third order IMD is also a key predictor for spectral regrowth associated with digital modulation formats.

**Figure 1-2**  
**Two-Tone Intermodulation Distortion**

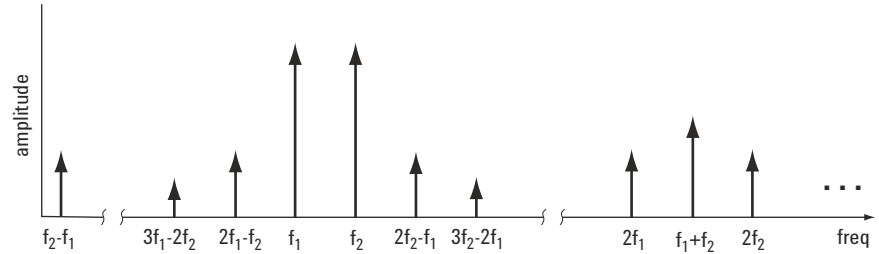

**Figure 1-3**  
**Two-Tone Intermodulation Distortion Measurement Setup**

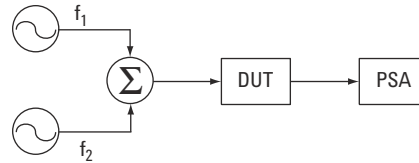

This procedure focuses on the measurement of third order IMD for two CW tones present at the input of a DUT. In a similar vein to the harmonic distortion measurement procedure, the suggested configuration ensures that IMD products generated by the analyzer are at least 18 dB below the IMD products of the DUT. Again, this guarantees that the distortion measurement error due to internal distortion added to DUT distortion is less than 1 dB.

### Measurement Setup:

Figure 1-3 shows the test setup for making a two-tone, third order IMD measurement.

As with the harmonic distortion measurement, the DUT can be a two- or three-port device. If the DUT is a mixer, then it is assumed that the LO source is included in the DUT block and that the output frequencies will be frequency-translated versions of the input frequencies. This procedure can also be used to measure the

intermodulation of the two sources themselves. The measurement requires two sources using a means of power combination with adequate isolation such that the sources do not create their own IMD. Do not treat this part of the measurement lightly; see Part V for a detailed description on source power combination techniques. Filtering may be required between the power combiner and the DUT to remove unwanted harmonics. For the same reason, additional filtering may be required between the DUT and the analyzer. Again, see Part V for more information. Source 1 is tuned to one of the fundamental frequencies,  $f_1$ , and Source 2 is tuned to the other fundamental tone frequency,  $f_2$ . The frequency separation,  $\Delta f$ , of the two input tones is sometimes referred to as the tone spacing. The upper third order IMD component falls at a frequency of  $2 \times f_2 - f_1$  (or  $f_1 + 2 \times \Delta f$ ) and the lower third order IMD component falls at a frequency of  $2 \times f_1 - f_2$  (or  $f_1 - \Delta f$ ). For best results, if applicable, the frequency references of all the sources and the analyzer should be locked together.

---

**Setup PSA Series Analyzer:**

Auto Couple                      Couples RBW filter, VBW filter, Span and Sweep time.  
     Couples Reference Level and Input Attenuator.

AMPLITUDE: More: More: Max Mxr Lvl: < -50 > : dBm  
     Limits power at input mixer to less than -50 dBm.

SPAN: < frequency span > GHz, MHz, kHz or Hz  
     Sets frequency span to be less than the separation frequency,  $\Delta f$ , to ensure that only one tone is displayed at a time.

FREQUENCY: CF Step : <  $\Delta f$  >: GHz, MHz, kHz or Hz

Bw / Avg: < .1 >                      Couples the VBW filter and the RBW filter with a bandwidth ratio of 1:10.

---

**Tune to the lower fundamental tone frequency:**

FREQUENCY: Center Freq: <  $f_1$  >: GHz, MHz, kHz or Hz.  
     If the DUT is a mixer, then tune to the translated frequency corresponding to  $f_1$ .

AMPLITUDE: Ref Level: < Reference Level Value > :dBm  
     Set Reference Level Value to be higher than the DUT's fundamental tone output power.

Peak Search                      Marker will position itself at the peak of the fundamental at frequency  $f_1$ .

Fine tune the DUT's output power while monitoring the PSA's marker amplitude value.

Marker →: Mkr → Ref Lvl  
     Brings displayed fundamental amplitude to the top line of the display graticule to optimize display range.

Marker: Delta                      Activates the Delta Marker where the reference is the fundamental tone at frequency  $f_1$ .

---

**Tune to the upper fundamental tone frequency:**

FREQUENCY: Center Freq:  $\uparrow$   
     If the DUT is a mixer, the frequency translation may reverse the frequency orientation of the tones, in which case substitute a down arrow hardkey,  $\downarrow$ , for the up arrow key in the rest of this procedure.

In most cases, the fundamental tones are adjusted to have the same power levels. If so, then adjust the Source 2 power level for a displayed delta marker amplitude of 0 dB. Otherwise, adjust the Source 2 power level to the desired difference from the Source 1 power level.

---

**Tune to the upper IMD product:**

FREQUENCY: Center Freq: ↑

SPAN: ↓ : ↓ : ↓, etc. Spanning down in frequency will automatically reduce the RBW value, which in turn reduces the displayed noise.

Span down until the distortion product is at least 5 dB above the noise floor. If the noise floor falls below the bottom of the display then follow this procedure:

AMPLITUDE: Attenuation: Attenuation

'Man' should be underlined. This de-couples the input attenuator from the reference level.

AMPLITUDE: Ref Level: ↓ : ↓, etc.

Maximum power at the mixer is not altered by changing the Reference Level setting

For distortion products close to the noise floor, the variance of the signal amplitude can be reduced by lowering the VBW value.

Bw / Avg: Video BW: ↓ : ↓, etc.

The marker delta amplitude value is the upper IMD product power relative to the fundamental tone power.

---

**Tune to the lower IMD product:**

FREQUENCY: Center Freq: ↓, ↓, ↓

The marker delta amplitude value is the lower IMD product power relative to the fundamental tone power.

---

**To compute output TOI (Third Order Intercept) power level:**

$TOI [dBm] = DUT \text{ Output Power of each tone } [dBm] + \Delta/2$

DUT Output Power is the reference level value read off the display minus any loss between the DUT and the input of the PSA series analyzer. Note that the power is the power of each tone and not the combined power of the two tones.  $\Delta$  is the negative of the marker delta amplitude value;  $\Delta$  is a positive value. In most cases TOI is computed using the higher amplitude of the upper or lower distortion products yielding the more conservative TOI result.



## Small Signal Desensitization

Small signal desensitization measurement is a form of a gain compression test on components intended for use in receiver architectures.

Another term for this measurement is two-tone gain compression. This measurement predicts the amount of gain change of a relatively low power signal in the presence of other high power signals.

Network analyzers commonly are used to measure the gain compression level of a nonlinear device. However, the spectrum analyzer is quite capable of measuring gain compression as well. Whereas the network analyzer approach sweeps the power of a single tone at a fixed frequency to characterize and display the power-out vs. power-in response, the spectrum analyzer approach uses two tones in a test setup similar to the two-tone intermodulation distortion measurement procedure. One tone at a lower power level is

**Figure 1-4**  
**Two-Tone Gain Compression Measurement Setup**

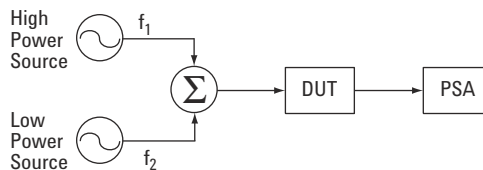

monitored by the spectrum analyzer while the other tone at a much higher power level drives the DUT into gain compression. When in gain compression, the amplitude of the lower power tone decreases by the gain compression value (that is, for a 1 dB gain compression measurement, the amplitude of the lower power tone is 1 dB lower than when the higher power tone is turned off). When the desired gain compression is reached, the amplitude of the higher power tone is measured by the spectrum analyzer.

The two-tone method is not recommended for high power amplifiers in which a large CW signal could cause localized heating, thereby affecting the measured results. In these cases the network analyzer is more appropriate. For more information refer to the techniques in reference [3].

### Measurement Setup:

The measurement setup for the two-tone gain compression test is shown in Figure 1–4.

The isolation requirements for the signal combiner described for the IMD measurement do not apply to the gain compression test. The separation frequency of the two sources must be within the bandwidth of the DUT. The high power source needs enough power to drive the DUT into gain compression. The power level of the low power source is set at least 40 dB below the power level of the high power source.

---

### Setup PSA Series Analyzer:

Auto Couple                      Couples RBW filter, VBW filter, Span and Sweep time.  
Couples Reference Level and Input Attenuator.

AMPLITUDE: More: More: Max Mxr Lvl: < -10 > : dBm  
Default setting.

AMPLITUDE: Ref Level: < Reference Level Value >: dBm  
Reference Level must be greater than the anticipated  
DUT output power at gain compression.

AMPLITUDE: Attenuation: Attenuation  
The 'Man' should be underlined. The PSA series' Input  
Attenuator is now de-coupled at a setting where the  
analyzer will not be driven into compression.

---

### Tune to the Low Power Source Frequency:

FREQUENCY: Center Freq: <  $f_2$  > : GHz, MHz, kHz or Hz.  
If the DUT is a mixer, then tune to the translated  
frequency corresponding to  $f_2$ .

Set the Source 2 power level such that the displayed  
DUT output amplitude at frequency  $f_2$  is at least  
40 dB below the estimated DUT output power  
at gain compression.

SPAN: ↓, ↓, etc.                      Span down until the displayed amplitude at  $f_2$  is at  
least 20 dB above the noise floor.

Bw / Avg: Video BW: ↓, ↓, etc  
Reduce video bandwidth to reduce amplitude variance  
due to noise.

---

### Drive DUT into Compression:

First, reduce Source 1 power such that the DUT  
is not gain compressed. Or better yet, turn off the  
Source 1 power.

Marker: Delta                      Activate the delta marker.

Increase Source 1 power until Delta Marker amplitude  
decreases by the desired gain compression amount.  
For example, if DUT output power at 1 dB gain  
compression is desired, then increase Source 1 power  
until the Delta Marker amplitude decreases by 1 dB.

---

### Measure DUT Output Power:

FREQUENCY: Center Freq: <  $f_1$  >: GHz, MHz, kHz or Hz  
Tune to Source 1 frequency.

Marker: Normal                      Turn off the delta marker mode.

Marker amplitude is the DUT output power at the  
specified gain compression level. The digital IF in the  
PSA series allows valid measurement of signals whose  
amplitudes fall above or below the display graticule.  
As long as the 'Final IF Overload' message is not  
present, the marker amplitude is valid.

## Spectral Regrowth of a Digitally Modulated Signal

Digital modulation employing both amplitude and phase shifts generates distortion known as spectral regrowth. As depicted in Figure 1–5, spectral regrowth falls outside the main channel into the lower and upper adjacent channels.

Like other distortion measurements, the spectrum analyzer creates its own internally generated distortion which, in the case of digitally modulated signals, is called spectral regrowth. In most cases, the spectral regrowth distortion generated within the spectrum analyzer is third order, meaning that for every 1 dB increase in main channel power, the spectral regrowth power increases by 3 dB. In addition to spectral regrowth, phase noise and broadband noise of the spectrum analyzer also limit the dynamic range of this type of distortion measurement.

Adjacent Channel Power Ratio (ACPR) is the measure of the ratio of the main channel power to the power in either of the adjacent channels. Some modulation formats require a spot measurement where power measurements are made at specific frequency offsets in the main and adjacent channels. Other formats require an integrated power measurement where the spectrum analyzer individually computes the total

**Figure 1–5  
Spectral Regrowth of a Digitally Modulated Signal**

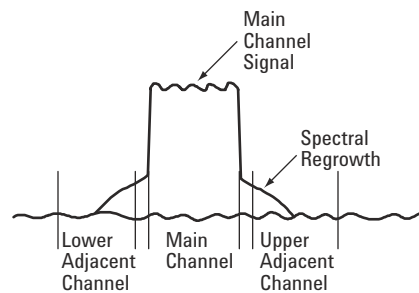

power across the entire main channel and each of the adjacent channels. In either case the user must set the proper mixer level of the spectrum analyzer to minimize the internally generated spectral regrowth. However, minimizing internally generated spectral regrowth comes at the price of increasing broadband noise, therefore a balance

must be reached between the two. Another complicating matter with digitally modulated signals is that the mixer level cannot be set based on average power at the mixer alone. The peak-to-average ratio of the modulated signal affects the amount of internally-generated spectral regrowth and must be factored into the setting of the mixer level.

### Setup PSA Series Analyzer:

- Auto Couple**      Couples RBW filter, VBW filter, Span and Sweep time. Couples Reference Level and Input Attenuator.
- Bw/Avg: Resolution BW:** < RBW Value >  
Set RBW Value to the specified setting according to the modulation format guidelines. RBW setting must be much less than the modulation bandwidth.
- Frequency: Center Freq:** < Main Channel Frequency > GHz, MHz, kHz or Hz
- Span:** < Span >      Set span in order to view the main channel and the adjacent channels.
- Det/Demod: Detector:** Average  
Activates the Averaging detector, which reports the average signal amplitude between trace display points.
- Sweep:** < Sweep Time >      With the average detector on, longer sweep times reduce the displayed variance of a noise-like signal.
- Amplitude: Ref Level:** < Reference Level Value >  
Set Reference Level Value in order to place the main channel amplitude near the top of the display.
- Amplitude: Attenuation** < Attenuation Value > dB  
Start from a low attenuation setting. Increase attenuation until spectral regrowth amplitude in the adjacent channel no longer changes. Then increase attenuation by 10 dB.
- Marker: Span Pair: Center:** < Main Channel Center Frequency >
- Marker: Span Pair: Span:** < Channel Bandwidth >  
Record marker amplitude value.  
This is the main channel power in dBm.
- Marker: Span Pair: Center:** < Adjacent Channel center frequency >  
Record marker amplitude value.  
This is the adjacent channel power.

ACPR = Main channel power - Adjacent channel power [dB].

## Part II: Mixer Level Optimization

The distortion measurements detailed in Part I have the spectrum analyzer configured such that its internally generated distortion products fall below the distortion being measured. While guaranteed to make accurate measurements by ensuring that the spectrum analyzer generated distortion does not mask the DUT generated distortion, these techniques do not allow full use of the available dynamic range of the spectrum analyzer. In order to make distortion measurements on highly linear devices whose distortion is already very low, the user must override the auto-couple features of the spectrum analyzer. Removing the auto-coupling allows more flexibility in optimizing the dynamic range of the spectrum analyzer. Beginning with this part, techniques pertaining to optimizing the PSA series settings for maximum distortion measurement capability are explained. This discussion begins with setting the mixer level.

Controlling the amount of power present at the first mixer of the spectrum analyzer is the first step in making distortion measurements. Optimizing this power, known as the mixer level, maximizes the dynamic range of the spectrum analyzer. Where a mixer level is set too low, the spectrum analyzer noise floor limits the distortion measurement. Where a mixer level is set too high, the distortion products generated within the spectrum analyzer limit the distortion measurement. The

**Figure 2-1**  
**Spectrum Analyzer**  
**Pout vs. Pin**  
**Characteristic**

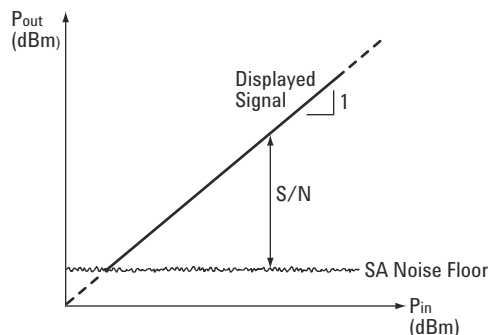

dynamic range charts found in many spectrum analyzer data sheets show the dynamic range plotted against the mixer level. This is an extremely useful tool in understanding how to best set the mixer level for second harmonic distortion and third order intermodulation distortion measurements. Normally the dynamic range charts in data sheets use specified spectrum analyzer performance and not the better typical performance. Learning how to construct these charts not only assists in understanding how to use them, but it also allows flexibility so that the user can customize the chart for actual spectrum analyzer performance.

Signal-to-noise ratio, signal-to-distortion ratio and phase noise contribute to the construction of the dynamic range chart. All of these individual terms will be discussed starting with signal-to-noise versus mixer level.

### Signal-to-Noise versus Mixer Level

The spectrum analyzer can be thought of as a two-port device characterized by a power-out versus power-in transfer function, as shown in Figure 2-1.

Power-in ( $P_{in}$ ) is the power present at the RF input port and power-out ( $P_{out}$ ) is the signal as it appears on the display of the spectrum analyzer. Both axes of the graph indicate RMS power of a CW signal. The apparent gain of the spectrum analyzer is 0 dB, meaning that the displayed amplitude is the value of the power at the RF input port. The noise floor of the spectrum analyzer places a limitation on the smallest amplitude that can be measured. Displayed Average Noise Level (DANL) is the noise floor as it appears on the display. For the PSA series, specified DANL is given in units of dBm/Hz (the noise is normalized to a 1 Hz Resolution Bandwidth setting, measured in a 0 dB Input Attenuation setting). Additionally, specified DANL in the PSA series is measured using the Log-Power (Video) averaging scale. (More on this subject later).

Figure 2-1 demonstrates that for every 1 dB drop in input power, the output signal-to-noise ratio (S/N) drops by 1 dB. Input power can be reduced in one of two ways: either the power level is decreased externally or the spectrum analyzer Input Attenuation is increased.

Another way of presenting the information in Figure 2-1 is to plot S/N versus power at the input mixer. Figure 2-2 shows this plot. The straight line data representing DANL relative to mixer level (or inverted S/N) has a slope of -1 signifying that for every 1 dB decrease in power at the input mixer, the S/N decreases 1 dB. The spectrum analyzer's DANL value locates the anchor point for the straight line. At the y-axis 0 dBc point, the x-axis mixer level is the DANL for 1 Hz RBW and 0 dB Input Attenuation. For example, in Figure 2-2, the spectrum analyzer DANL is -155 dBm in a 1 Hz RBW, measured with 0 dB Input Attenuation.

The noise floor of the spectrum analyzer can be affected in two ways. One is with the RBW setting. The noise floor rises over the 1 Hz normalized DANL value according to the equation:  $10 \log(\text{RBW})$ ; where RBW is the Resolution Bandwidth setting in Hz. Increasing the RBW by a factor of 10 increases the noise floor by 10 dB. Figure 2-3 shows the noise floor with 1 Hz, 10 Hz and 1 kHz settings, demonstrating that the noise floor increases by 10 and 30 dB respectively relative to the 1 Hz RBW setting.

The other mechanism that affects the displayed noise floor is the averaging scale. Averaging scale selection is found under the Mode Setup hardkey, Avg/VBW type softkey. The PSA series has two averaging scales for power measurements: Log-Power (Video) and Power (RMS). We discuss the distinction between these two averaging scales at this point because of their affect on displayed noise. Later we will discuss which averaging scale is most appropriate for the type of distortion measurement being made.

**Figure 2-2**  
Signal to Noise vs. Power at the Input Mixer

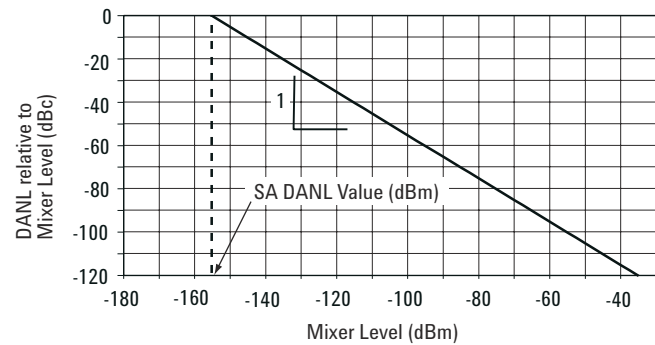

**Figure 2-3**  
Noise Floor with Different RBW Settings

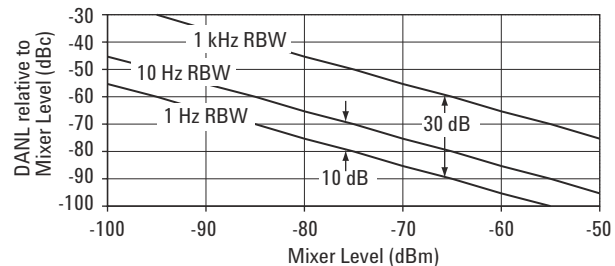

**Figure 2-4**  
Averaging Scale Effect on Displayed Noise

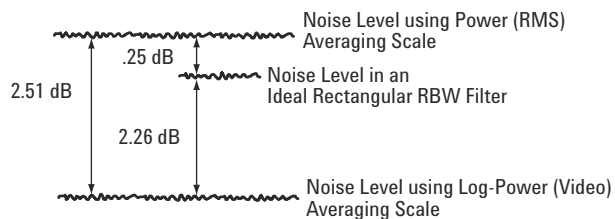

Figure 2-4 shows the relationship between noise, displayed noise using the Log-Power (Video) scale, and displayed noise using the Power (RMS) scale.

Ideally, noise is measured using a rectangular filter that has a flat passband response and infinite attenuation in the stopband.

However, the PSA series measure all signals, including noise, using RBW filters that approximate a Gaussian response. These filters offer much better time domain performance than the theoretical rectangular RBW filter. The consequence of using non-rectangular RBW filters is that, when subjected to noise with a flat power spectral density, the noise that falls outside of the specified -3 dB bandwidth will be measured along with the noise that falls inside the passband of the filter. So, if the rectangular RBW filter has the same bandwidth as the near-Gaussian RBW filter, the measured noise power will be greater when using the RBW filter. Noise-power bandwidth (or equivalent noise bandwidth) describes the bandwidth of an ideal rectangular filter (this is different than the ideal rectangular RBW filter!) whose power response is the same as the power response of the actual filter used for the noise measurement. For

PSA series, the noise-power bandwidth (NBW) of any RBW filter is approximately 6 percent wider than its -3 dB bandwidth. The ratio of the NBW to the -3 dB bandwidth of a RBW filter is the power gain when measuring noise or noise-like signals. For the PSA series this power gain is  $10 \times \text{Log}(1.06)$  or +0.25 dB.

The displayed noise power of the PSA series when using the Power (RMS) averaging scale is 0.25 dB higher than when using the ideal rectangular RBW filter, indicating that it reports the NBW filter power response. As the name implies, the Power averaging scale reports the power of the signal, whether this signal be Gaussian noise, CW, or a signal with modulation. This power measurement is equivalent to the root-mean-square of the signal voltage.

When using the Log-Power (Video) averaging scale, Gaussian noise is displayed 2.51 dB lower in power than when using the Power (RMS) averaging scale. References [1] and [4] explain the reasons for the under-response of noise when using the Log-Power averaging scale. To compute the noise in an ideal rectangular RBW filter from the noise measured using the Log-Power averaging scale, add 2.51 dB to correct for logarithmic averaging scale conversion and subtract 0.25 dB to account for the ratio of NBW to the -3 dB bandwidth of the RBW filter. The total correction for the PSA series is +2.26 dB.

One important point is that the measured amplitude of CW signals does not change with averaging scale. Log-Power (Video) averaging scale is preferred for measuring CW signals because it gives 2.51 dB of added S/N over the Power (RMS) display scale. The Power (RMS) display scale is the proper averaging scale when measuring digitally modulated signals that have noise-like behavior. As explained in reference [4], if the statistics of the modulated signal are not exactly known, the 2.51 dB correction factor that strictly applies to white Gaussian noise cannot be assumed. The hard to quantify offsets associated with the Log-Power (Video) scale do not exist in the Power (RMS) scale when measuring modulated signals with unknown power statistics.

### Signal-to-Noise with Excess Noise

The S/N vs. mixer level graph also works when the noise at the input is greater than the noise floor of the spectrum analyzer, something not all that uncommon, especially when preamplifiers are used as part of the measurement system. This excess noise can stem from devices with relatively low signal-to-noise ratios as compared with the spectrum analyzer. Some examples of these devices are signal sources and elements in receiver architectures. In this discussion, we are concerned with excess broadband noise, not close-in phase noise.

Figure 2-5 depicts the situation where the external noise from the DUT is greater than the noise floor of the spectrum analyzer (SA). At higher signal power levels the external signal-to-noise ratio stays constant. As the input signal power decreases, the external noise falls below the noise floor of the spectrum analyzer, in which case the S/N decreases in the familiar 1 dB per 1 dB of signal power reduction.

Figure 2-6 shows how external noise appears on the S/N versus mixer level graph. At higher powers, the DANL relative to the power at the mixer stays constant and at lower mixer levels the S/N curve shows the familiar slope of -1. The SA Noise and the external noise add as uncorrelated powers such that at the intersection of the SA noise and the

**Figure 2-5**  
SA Pout vs. Pin with External Noise

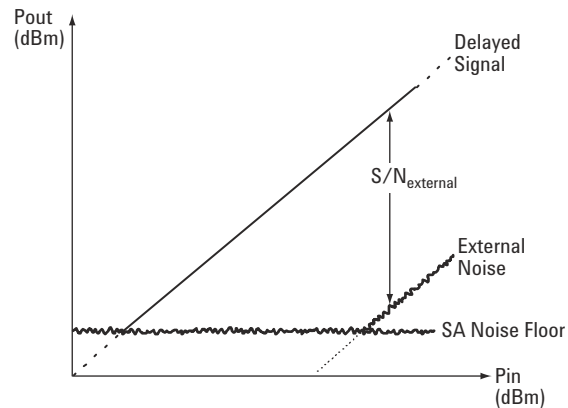

**Figure 2-6**  
Signal-to-Noise vs. Mixer Level with External Noise Greater than SA Noise

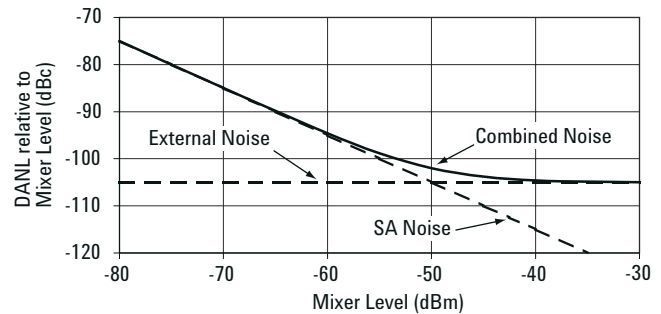

external noise curves, the combined noise is 3 dB higher than the two individual contributors alone. The external noise as displayed on the spectrum analyzer follows the same dependency on RBW setting as the SA noise, such that for every decade increase in RBW value, both the SA Noise and the external noise curves shift up by 10 dB on the dynamic range chart.

### Signal-to-Distortion versus Mixer Level

Distortion products can also be viewed on the Power-out vs. Power-in graph. Figure 2-7 shows that Nth order distortion product amplitudes increase N dB for every dB of fundamental tone power increase. The signal-to-distortion ratio (S/D) decreases N-1 dB for every 1 dB of increase in fundamental tone power. Above a certain power level, however, the spectrum analyzer gain compresses, at which point the output power no longer increases in a linear relationship when plotted on a log power scale. By extrapolating the

below gain compression  $P_{out}$  vs.  $P_{in}$  curves for both the fundamental tone and the distortion products, the two lines cross at a fictional output power level above gain compression. The output power where these two lines meet is termed Third Order Intercept (TOI) for third order intermodulation distortion and Second Harmonic Intercept (SHI) for second harmonic distortion.

For the spectrum analyzer, TOI and SHI are specified with respect to the power at the input mixer. Another way of thinking about these specifications is that TOI and SHI are measured assuming 0 dB Input Attenuation. Referring to Figure 2-8, SHI is calculated as:  $SHI = P + \Delta$ ; where  $P$  is the input power minus the Input Attenuation value and  $\Delta$  is the dB difference between the second order distortion product power level and the fundamental tone power level ( $\Delta$  is a positive value). TOI is measured assuming two equal power tones at the input and is calculated as:  $TOI = P + \Delta/2$ . In this case  $P$  is the power at the input mixer of each tone;  $P$  is not the combined tone power, which would be 3 dB higher. Again  $\Delta$  is the power difference between each fundamental tone and the intermodulation distortion product and is a positive value. If the two intermodulation products have unequal amplitudes, the product with the higher amplitude is used, giving a worst-case TOI result.

Having demonstrated the conversion of S/N from the Power-out versus Power-in graph to the S/N versus mixer level graph, we can also plot S/D versus mixer level. Figure 2-9 shows distortion relative to mixer level (or inverted signal-to-distortion) in dBc units versus the input power at the mixer for second and third order distortion.

**Figure 2-7**  
Pout vs. Pin Curves for Distortion

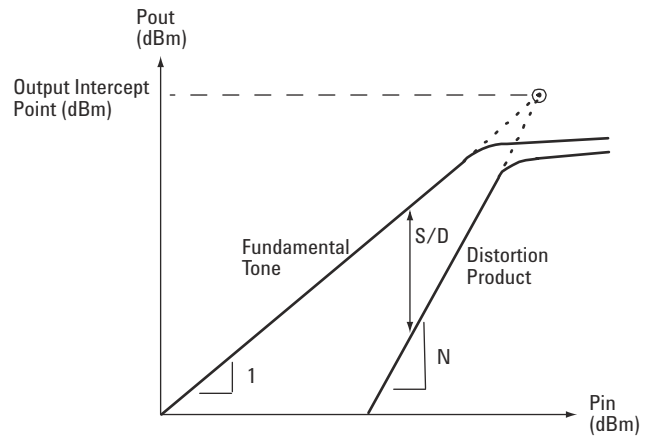

**Figure 2-8**  
Second and Third Order Distortion Spectrum

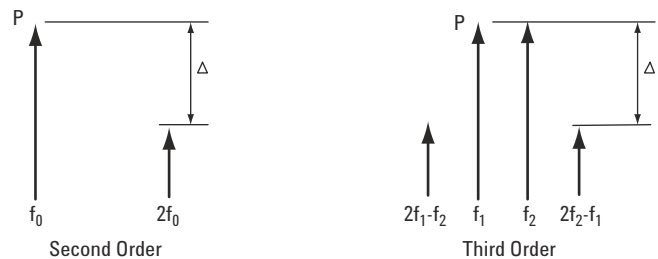

**Figure 2-9**  
Signal to Distortion versus Power at the Input Mixer

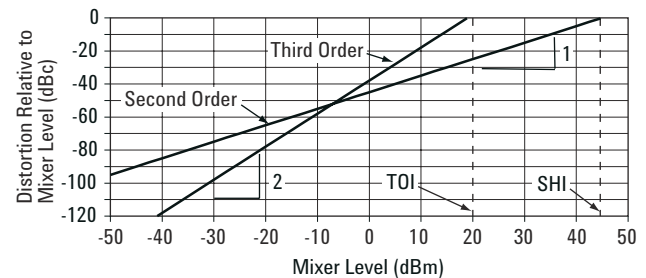

For second order distortion the slope of the S/D versus mixer level curve is +1, signifying that for every 1 dB increase in power at the mixer, the S/D decreases 1 dB. For third order the slope of this curve is +2; for every 1 dB increase in the two fundamental tone power levels, the S/D decreases by 2 dB. For the second harmonic curve the 0 dBc

intersection point on the y-axis corresponds to the SHI value in dBm on the x-axis. In the example shown in Figure 2-9, the SHI performance of the spectrum analyzer is +45 dBm. For the third order curve the 0 dBc intersection point on the y-axis corresponds to the TOI value in dBm. In this example, the TOI of the spectrum analyzer is +20 dBm.



## The Dynamic Range Chart

Combining the signal-to-noise and the signal-to-distortion versus mixer level curves into the same graph yields the dynamic range chart as shown in Figure 2-10.

The dynamic range chart allows a visual means of determining the maximum dynamic range and the optimum power at the first mixer where the maximum dynamic range occurs. Using simple geometry on the curves that make up the dynamic range chart yields closed form equations for maximum dynamic range and optimum mixer level.

**Figure 2-10**  
**Dynamic Range**  
**Chart**

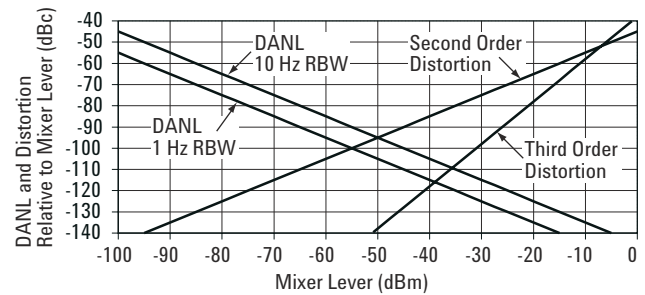

---

### Second Harmonic Distortion:

$$\text{Maximum Dynamic Range} = \frac{1}{2} \text{SHI} - \text{DANL} \text{ dB} \quad (2-1)$$

$$\text{Optimum Mixer Level} = \frac{1}{2} [\text{SHI} + \text{DANL}] \text{ dBm} \quad (2-2)$$

---

### Third Order Intermodulation Distortion:

$$\text{Maximum Dynamic Range} = \frac{2}{3} [\text{TOI} - \text{DANL}] \text{ dB} \quad (2-3)$$

$$\text{Optimum Mixer Level} = \frac{1}{3} [2 \times \text{TOI} + \text{DANL}] \text{ dBm} \quad (2-4)$$

For example, the values in Figure 2-10 are:

DANL = -145 dBm in 10 Hz RBW

TOI = +20 dBm

SHI = +45 dBm

Second Order Distortion in 10 Hz RBW:

$$\text{Maximum Dynamic Range} = \frac{1}{2} [45 - (-145)] = 95 \text{ dB}$$

$$\text{Optimum Mixer Level} = \frac{1}{2} [45 - 145] = -50 \text{ dBm}$$

Third Order Intermodulation Distortion in 10 Hz RBW:

$$\text{Maximum Dynamic Range} = \frac{2}{3} [20 - (-145)] = 110 \text{ dB}$$

$$\text{Optimum Mixer Level} = \frac{1}{3} [2 \times 20 - 145] = -35 \text{ dBm}$$

### Adding Phase Noise to the Dynamic Range Chart

Phase noise, due to either the DUT or the spectrum analyzer, can hide distortion products, as demonstrated in Figure 2-11a. In this case, the third order intermodulation products fall under the phase noise skirt, preventing them from being measured.

Like broadband noise, the displayed phase noise floor also changes level with RBW setting, as shown in Figure 2-11b. The spectrum analyzer phase noise at a particular frequency offset is specified in dB relative to carrier in a 1 Hz bandwidth. This 1 Hz noise bandwidth assumes a phase noise measurement on a power scale with the over-response due to the ratio of the equivalent noise bandwidth to the -3 dB bandwidth of the RBW filter removed. The relationship of displayed broadband noise versus averaging scale depicted in Figure 2-4 also applies to phase noise. Therefore, if phase noise measurements are to be made using the Log-Power (Video) scale, which is the preferred display mode for CW signals, the phase noise value needs to be offset by -2.26 dBc from its specified level. When using the Power (RMS) averaging scale, the phase noise is offset by +0.25 dBc from its specified value.

Figure 2-12 demonstrates how phase noise appears on the dynamic range chart. Note that phase at one offset frequency is presented. For this case the specified phase noise at the particular offset frequency of interest is -110 dBc/Hz. Using the Log-Power (Video) averaging scale, the phase noise appears to be -110 minus 2.26 dB or -112.26 dBc normalized to the 1 Hz RBW. When using the Power display scale, the phase noise appears to be 2.51 dB higher than with the Log-Power display scale, or -109.75 dBc normalized to the 1 Hz RBW.

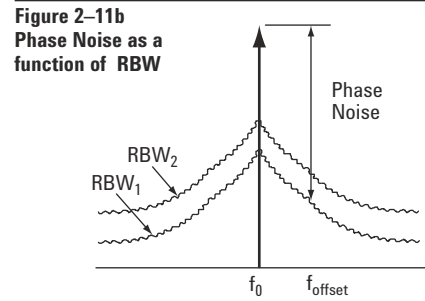
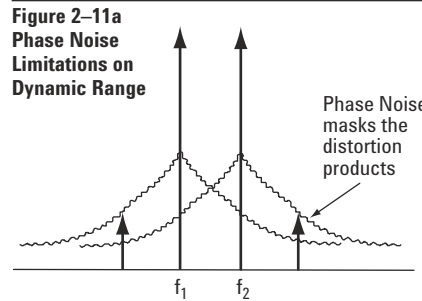

**Figure 2-12**  
Phase Noise Represented on the Dynamic Range Chart

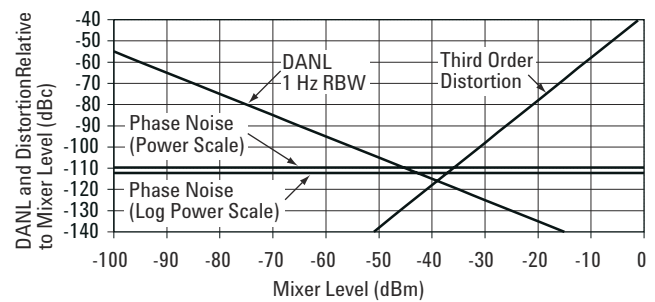

Referring to Figure 2-6 where external noise is shown adding to the broadband noise of the spectrum analyzer, when two uncorrelated noise signals combine, the resulting total power is computed as shown in equation 2-5.

$$\text{Total Power} = 10 \times \log(10^{(P1/10)} + 10^{(P2/10)}) \text{ [dBm]} \quad (2-5)$$

where P1 and P2 are the individual power terms in dBm

The phase noise and the broadband noise, being uncorrelated, also follow equation 2-5 when they combine. So, at the intersection of the phase noise and the DANL curves, assuming both are shown on the same display scale setting, the resulting total noise power is 3 dB higher than the two individual contributors.

## Noise Adding to the Distortion Product

This section concerns the measurement of CW-type distortion products measured near the noise floor when using the Log-Power averaging scale. An overview is given here, and references [4] and [6] explain this subject in greater detail.

When a CW tone amplitude is close to the noise floor, the signal and noise add together as shown in Figure 2-13.

The apparent signal is the signal and noise added together that the user would see displayed on the spectrum analyzer. Reference [4] gives this the name S+N for signal-plus-noise. The displayed signal-to-noise ratio is the apparent signal peak to the broadband noise (noise level with the CW tone removed). The term, actual signal-to-noise ratio, means the ratio of the true CW tone peak amplitude to the broadband noise level. The actual signal-to-noise ratio is somewhat lower than the displayed signal-to-noise ratio. Figure 2-14 shows graphically the signal-to-noise ratio error versus the displayed signal-to-noise ratio. The difference between the displayed S/N and the actual S/N is the signal-to-noise ratio error. This graph pertains to CW distortion measurements using the Log-Power (Video) averaging scale, not the Power (RMS) averaging scale

**Figure 2-13**  
CW Tone Plus Noise

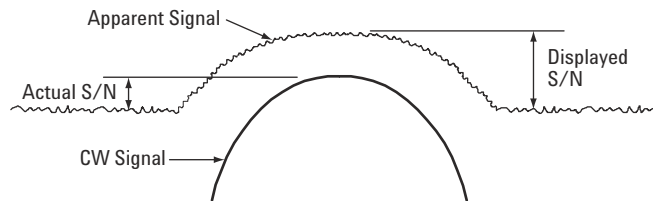

**Figure 2-14**  
S/N error versus displayed Actual S/N for CW Signals using a Log-Power Display

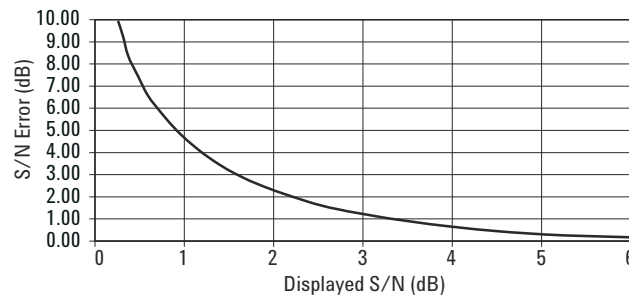

To use the graph shown in Figure 2-14, locate the displayed signal-to-noise ratio on the x-axis, then read off the error on the y-axis. Subtract this error value from the displayed signal amplitude to compute the true CW signal amplitude. For example, suppose the displayed S/N is 3 dB for a displayed signal measuring -100 dBm. The corresponding error is 1.1 dB, which means that the true signal amplitude is -100 dBm minus the 1.1 dB error term, or

-101.1 dBm. One key observation is that when the CW tone amplitude is equal to the broadband noise level, that is, 0 dB actual S/N, the displayed S/N is approximately 2.1 dB. For an error in the displayed S/N to be less than 1 dB, the displayed S/N should be at least 3.3 dB.

When making distortion measurements on CW-type signals, the information in Figure 2-14 can be transferred to the dynamic range chart. Figures 2-15 and 2-16 show how the second and third order dynamic range curves change as a result of noise adding to the distortion products.

Below the solid, heavy lines representing distortion-plus-noise, the CW distortion products are not discernible. This translates to a reduction in the spectrum analyzer's maximum dynamic range. Both the second and third order maximum dynamic ranges reduce by approximately 2.1 dB when the effect of noise is added to the CW distortion products displayed on the Log-Power scale. The corresponding optimum mixer level is offset by +0.5 dB for second harmonic distortion and by -0.36 dB for third order intermodulation distortion. All of these values are relative to the ideal maximum dynamic ranges and optimum mixer levels given by equations 2-1 through 2-4.

Figures 2-15 and 2-16 show the reduced dynamic range assuming no steps are taken to remove the near-noise measurement errors. The S/N Error versus Displayed S/N graph (Figure 2-14) indicates that white Gaussian noise adding to a CW signals results in a predictable amount of error, which is different than an uncertainty. To regain the lost 2.1 dB of dynamic range, one could measure the displayed S/N of the near-noise distortion product and, using the information in Figure 2-14, remove the corresponding error value.

**Figure 2-15**  
Dynamic Range Chart with Noise Added to the CW Second Order Distortion Products

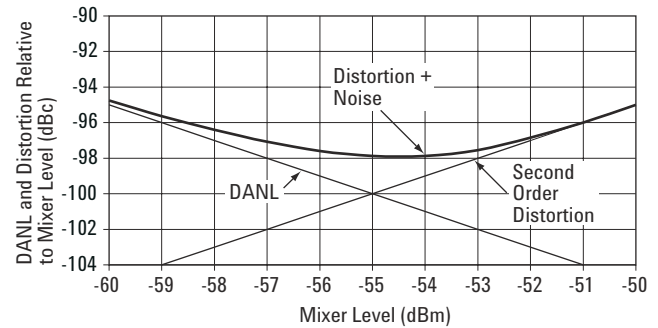

**Figure 2-16**  
Dynamic Range Chart with Noise Added to the CW Third Order Distortion Products

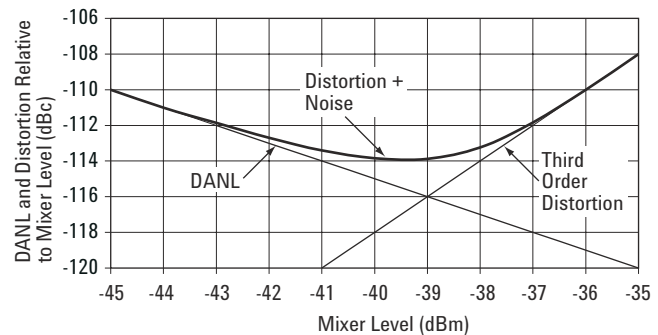

## SA Distortion Adding to DUT Distortion

When the amplitudes of the distortion products of the DUT fall close to the amplitudes of the internally generated distortion products of the spectrum analyzer, an uncertainty in the displayed distortion amplitude results. The DUT distortion products fall at the same frequencies as the SA generated distortion products such that they add as voltages with unknown phases. The error uncertainty due to the addition of two coherent CW tones is bounded by the values shown in equation 2-6.

$$\text{Uncertainty} = 20 \times \text{Log} (1 \pm 10^{d/20}) \text{ dB} \quad (2-6)$$

where 'd' is the relative amplitudes of the two tones in dB (a negative number).

+ is the case where the DUT and SA distortion products add in-phase.

- is the case where the DUT and SA distortion products add 180 degrees out of phase.

Equation 2-6 is shown graphically in Figure 2-17. The amplitude error could vary anywhere between the two curves.

For the situation when the internally generated distortion product is equal in amplitude to the external distortion product, and they are in-phase, the resulting displayed amplitude could be 6 dB higher than the amplitudes of the individual contributors. For individual contributors of equal amplitude that are 180 degrees out of phase, these signals would completely cancel, resulting in no displayed distortion product.

**Figure 2-17**  
Amplitude Uncertainty due to Two Coherent CW Tone Adding Together

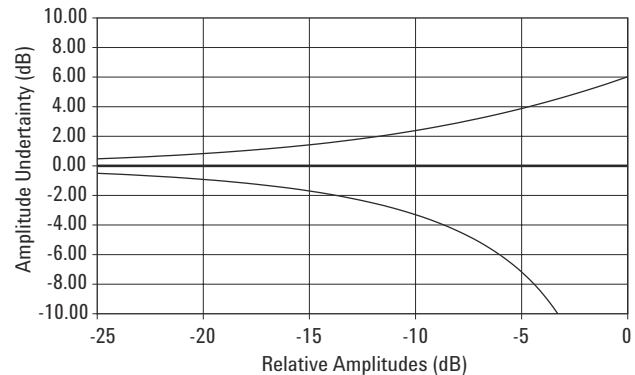

Equation 2-6 and Figure 2-17 apply without qualification to harmonic distortion measurements. For two-tone intermodulation distortion measurements there is an exception. For most distortion measurements, the input power at the spectrum analyzer's first mixer is far below its gain compression level, making the spectrum analyzer a weakly-nonlinear device. Reference [5] makes the case that for cascaded stages that exhibit a weak nonlinearity, the intermodulation distortion components add in-phase only. Tests performed on the PSA series confirm this conclusion if the tone spacing is no greater than 1 MHz. Thus for two tone intermodulation measurements with tone spacing  $\leq 1$  MHz, the displayed amplitude error due to two distortion products adding is given by equation 2-7.

$$\text{Amplitude error} = 20 \times \text{Log} (1 + 10^{d/20}) \text{ dB} \quad (2-7)$$

where 'd' is the relative amplitudes in dB between the internally generated distortion and the external DUT generated distortion amplitudes (a negative number).

To ensure that measurement error due to the combination of DUT and SA distortion products falls below a given threshold, the optimum mixer requires readjustment. Unfortunately, this readjustment has an adverse effect on the maximum dynamic range available from the spectrum analyzer. The following procedure helps compute the readjusted dynamic range and the resulting optimum mixer level needed to ensure that the distortion measurement uncertainty falls below a desired error level.

Start with a desired amount of maximum measurement error and, using the chart in Figure 2-17, read off the relative amplitudes corresponding to the desired threshold. For harmonic measurements or two-tone intermodulation measurements whose tone separations are  $> 1$  MHz, use the lower curve as it gives the most conservative result. For IMD measurements with tone separations  $\leq 1$  MHz, use the upper curve in Figure 2-16. Or instead, equations 2-6 and 2-7 could be solved for 'd', which is the relative amplitude value between external and internal distortion product amplitudes. The relative amplitude value is then used to determine how to offset the distortion curves in the dynamic range chart. Either offset the distortion

curves up by -d dB or offset the intercept point by d/(Intercept order -1). For example, for second order distortion, the effective SHI is offset by 'd' and for third order intermodulation the effective TOI is offset by 1/2 d. By offsetting the intercept points, instead of offsetting the curves on the dynamic range chart, equations 2-1 through 2-4 can be used to calculate the optimum mixer levels and the maximum dynamic ranges.

Here is an example of how to use the information presented on near noise and near distortion measurements. Consider the situation where RBW = 10 Hz, DANL = -155 dBm/Hz and SA TOI = +20 dBm. The objective is to compute the modified maximum third order intermodulation dynamic range and the optimum mixer level. Using equations 2-3 and 2-4, we earlier computed the ideal case maximum dynamic range as being 110 dB and the corresponding optimum mixer level as being -35 dBm. Suppose the error uncertainty due to DUT and SA distortion addition is to be less than 1 dB. Solve equation 2-7 for d:

$$d = 20 \times \text{Log}(10^{\text{dB Error}/20} - 1) \text{ dB}$$

$$d = 20 \times \text{Log}(10^{1/20} - 1) \text{ dB}$$

$$d = -18.3 \text{ dB}$$

The SA's effective TOI is computed as SA TOI - d/2 or +20 - 18.3/2 = +10.85 dBm. Figure 2-18 shows that the distortion curve has been shifted up by 18.3 dB, corresponding to an effective loss of 9.2 dB in SA TOI. An intermediate maximum dynamic range and optimum mixer level can be computed using the new effective TOI value:

Third Order Distortion in 10 Hz RBW:

$$\text{Maximum Dynamic Range} = \frac{2}{3}[10.85 - (-145)] = 103.9 \text{ dB}$$

$$\text{Optimum Mixer Level} = \frac{1}{3}[2 \times 10.85 - 145] = -41.1 \text{ dBm}$$

**Figure 2-18**  
Dynamic Range Chart Showing Valid Measurement Region for <1 dB Measurement Uncertainty for Third Order IMD

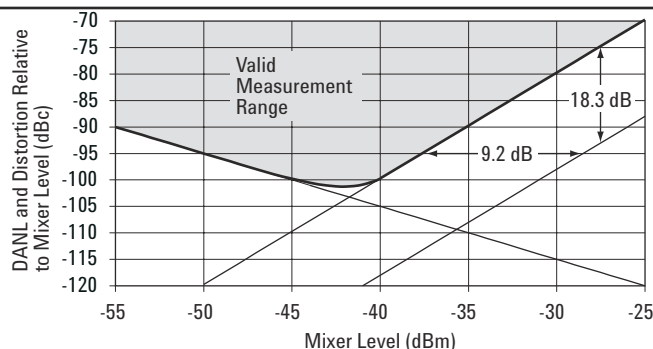

Thus in order to drive down measurement error, the loss in dynamic range is 6.1 dB and the optimum mixer level is shifted down in power by 6.1 dB.

But we are not done yet. Noise adds to the distortion product, contributing to a dynamic range loss of 2.1 dB and an optimum mixer level offset of -0.36 dB. If no steps are taken to remove this noise error, a final value for maximum dynamic range equals 101.8 dB with a corresponding optimum mixer level of -41.5 dBm. The valid measurement region is the area of the dynamic range chart where distortion interference error is below the desired error value and the distortion product is discernable above the noise floor. The valid measurement region for this example is shown in Figure 2-17. Keep in mind that the error due to near noise addition is still present. This error can be removed with the aid of the graph in Figure 2-14, resulting in an improvement of 2.1 dB in dynamic range.

One final note, we mentioned that when measuring TOI with tone spacing  $\leq 1$  MHz, the DUT distortion products add in-phase with the distortion products generated by the PSA series analyzers, resulting in what looks like an error term. This situation seems very similar to the near-noise case, in which the error term can be subtracted from the displayed amplitude of the CW signal. Theoretically, the TOI product addition is an error term, and theoretically, this error could be subtracted out to regain lost dynamic range. The difficulty with TOI is with the inability to accurately measure the TOI of the spectrum analyzer. Spectrum analyzer TOI fluctuates with tune frequency due to constantly changing match, as seen by the first mixer. To accurately measure SA TOI in the hopes of removing the error term, the same input match would be required for both the SA TOI measurement as well as the final DUT measurement. Removing the TOI related error term is not impossible, but for practical reasons it is best to consider the error term as an uncertainty that cannot be accurately removed from the measurement.

## Part III: Distortion Measurements on Digitally Modulated Signals

In Part II we concentrated on the distortion measurements of CW signals containing no modulation. In Part III, we turn our attention to out-of-channel leakage measurements, such as adjacent channel power (ACP) and alternate channel power on digitally modulated signals. Optimizing the mixer level of the spectrum analyzer is equally as important for these types of distortion measurements as it is for distortion measurements on CW signals. However, setting the mixer level for digitally modulated signals requires different considerations than what we will discuss here in Part III.

Reference [4] states that under conditions where the measurement bandwidth is much narrower than the modulation bandwidth ( $BW_m$ ) of a digitally modulated signal, the signal exhibits noise-like statistics in its amplitude distribution. In most practical cases, the spectrum analyzer RBW is much narrower than  $BW_m$  and satisfies the above condition. For example, when measuring adjacent channel power ratio (ACPR) on an IS-95 CDMA signal with a 1.23 MHz  $BW_m$ , the specified measurement RBW is 30 kHz. Why is the fact that the signal exhibits noise-like behavior important? First, unlike with CW tones, greater care must be exercised in selecting the display mode, both the display detector and the averaging scale, when measuring digitally modulated signals. Second, both the

displayed main channel power and the displayed spectral regrowth (that is, distortion products) are a function of the RBW setting of the spectrum analyzer. Finally, the manner in which the digitally modulated signal's noise-like distortion components and broadband noise add together behaves differently than when the distortion is CW. These points will all be discussed in greater detail in the following.

### Choice of Averaging Scale and Display Detector

One of the first considerations when measuring digitally modulated signals is the choice of the averaging scale (Log-Power vs. Power scale). In order for the digitally modulated signal to behave exactly like noise, its amplitude versus time characteristic must possess a Gaussian Probability Density Function (PDF). If the Gaussian PDF is assumed then the displayed main channel power spectral density (PSD) follows the same rules as white noise, where a 2.51 dB displayed amplitude difference occurs between measurements on the Log-Power (Video) scale and the Power (RMS) scale. However, if the PDF of the digitally modulated signal is not known exactly, which is usually the case, then the 2.51 dB offset does not necessarily hold true. The Power (RMS) averaging scale must be used for digitally modulated signals as this scale avoids the uncertainties incurred when computing the amplitudes on the Log-Power (Video) averaging scale.

The Peak detector and the Normal detector should not be used for measurements on digitally modulated signals. These detectors report the peak amplitude excursions that occur between display measurement cells, thus overemphasizing the amplitude peaks of noise and noise-like signals. The Sample detector, by contrast, reports the signal amplitude that occurs at the display measurement cell (sometimes referred to as display "bucket"), which does not peak bias the measurement. The PSA series analyzer has another detector, called the Average detector, which reports the average of the data across each display bucket. When using the Average detector, the longer the sweep time, the greater the amount of averaging. Either the Sample detector or the Average detector should be used for measurements on digitally modulated signals.

The Video Bandwidth (VBW) filter reduces the amplitude fluctuations of the displayed signals and, depending on the spectrum analyzer, is placed either before or after the linear to logarithmic conversion process in the intermediate frequency (IF) chain. One new feature in the PSA series analyzer not found in previous generation Agilent spectrum analyzers is that the VBW filter does not affect the power summation performed when using the Power (RMS) scale. When using spectrum analyzers in which the VBW filter is placed after the linear to logarithmic conversion process, the user is cautioned to keep the  $VBW \geq 3 \times RBW$  for the measurement of signals that are random in nature. This ensures that averaging occurs on the Power scale and avoids the offsets that occur on the log scale. When using the Power (RMS) averaging scale, the PSA series analyzer allows an arbitrarily narrow VBW setting without the worry that the measured amplitude will contain log scale uncertainties. This allows more flexibility to use the VBW to reduce the measured amplitude variance of the digitally modulated signal.

## Maximizing Spectrum Analyzer Dynamic Range

Three mechanisms inherent to the spectrum analyzer limit its dynamic range when measuring out of channel distortion on digitally modulated signals. These mechanisms are: the spectrum analyzer noise floor, the spectrum analyzer phase noise and the spectrum analyzer intermodulation distortion. The noise floor is always a limit as it is with CW distortion measurements. Phase noise and intermodulation, however, are limits that depend on such parameters as channel separation and modulation bandwidth. In other words, in the majority of cases, depending on the modulation format, phase noise or intermodulation will limit the dynamic range of the spectrum analyzer.

### Signal-to-Noise of Digitally Modulated Signals

The spectrum analyzer displays the main channel PSD at a level lower by  $10 \times \text{Log}(BW_m)$  than the amplitude of a CW tone with equal power. Figure 3-1a shows this effect. Furthermore, the displayed amplitude and displayed broadband noise are functions of the RBW setting which, unlike the CW case, renders the S/N independent of the RBW. See Figure 3-1b.

The displayed main channel PSD is  $P_{ch} - 10 \times \text{Log}(BW_m/RBW) + 10 \times \text{Log}(NBW/RBW)$ .  $P_{ch}$  is the total signal power and NBW is the noise power bandwidth of the RBW filter used for the measurement. For the PSA series analyzer NBW/RBW is 1.06 or  $10 \times \text{Log}(NBW/RBW) = 0.25$  dB. The following is an example for computing the displayed amplitude of a -10 dBm IS-95 CDMA signal measured with a 30 kHz RBW filter setting:

$$\text{Average Displayed Amplitude} = P_{ch} - 10 \times \text{Log}(BW_m/RBW) + 10 \times \text{Log}(NBW/RBW)$$

$$\text{Average Displayed Amplitude} = -10 - 10 \times \text{Log}(1.2288 \text{ MHz}/30 \text{ kHz}) + 10 \times \text{Log}(1.06)$$

$$\text{Average Displayed Amplitude} = -25.9 \text{ dBm}$$

**Figure 3-1a**  
Displayed Amplitude of a CW Tone and a Digitally Modulated Signal with Equal Powers

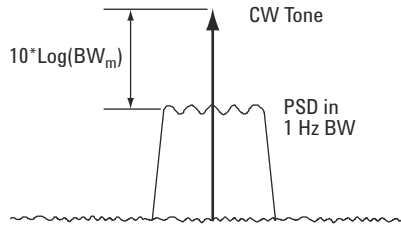

**Figure 3-1b**  
Displayed Amplitude of Both Digitally Modulated Signal and DANL varies with RBW

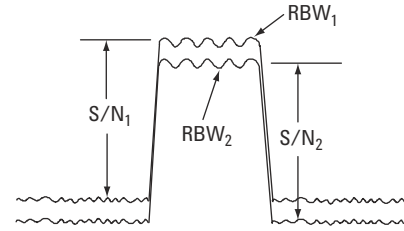

**Figure 3-2**  
S/N vs. Mixer Level for Digitally Modulated Signals

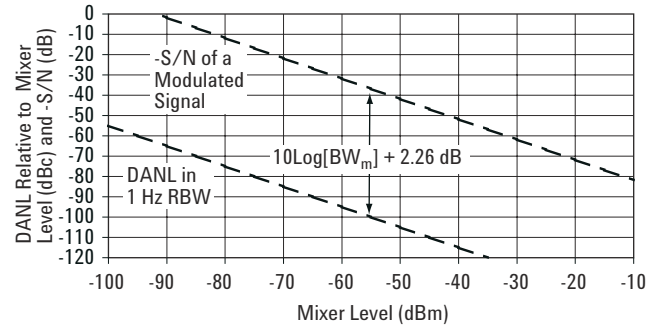

### S/N as a Function of Power at the first mixer

$$S/N = ML_{ch} - 10 \times \text{Log}(BW_m) + 10 \times \text{Log}(NBW/RBW) - \text{DANL} - 2.51 \text{ [dB]} \quad (2-8)$$

$$S/N = ML_{ch} - \text{DANL} - 10 \times \text{Log}(BW_m) - 2.26 \text{ [dB]}$$

Broadband noise on the Power (RMS) averaging scale appears at the specified DANL +  $10 \times \text{Log}(RBW) + 2.51$  + the Input Attenuator setting. So for a spectrum analyzer with a DANL of -155 dBm/Hz measured with a 30 kHz RBW filter with 10 dB of Input Attenuation, the displayed noise level on the Power Scale is:  $-155 + 10 \times \text{Log}(30 \text{ kHz}) + 2.51 + 10 = -97.7$  dBm. The signal-to-noise ratio computes to 71.8 dB.

For purposes of plotting the S/N on the dynamic range chart, it is best to

think of the channel power in terms of the power at the input mixer of the spectrum analyzer; call this power  $ML_{ch}$ .  $ML_{ch} = P_{ch} - \text{Input Attenuation}$ . Thus, S/N as a function of power at the first mixer is given by equation 2-8.

Equation 2-8 makes it evident that for digitallly modulated signals, the S/N is a function of the modulation bandwidth. Wider bandwidths lead to a lower S/N. Figure 3-2 shows the dynamic range chart with the S/N plotted against the input power at the first mixer for an IS-95 CDMA modulated signal. The S/N curve of the modulated signal is offset from the DANL curve by  $10 \times \text{Log}(BW_m) - 2.26$ .



### Spectral Regrowth Due to Spectrum Analyzer Intermodulation Distortion

Third, and in some cases fifth order intermodulation distortion of the spectrum analyzer create distortion products that fall outside of the main channel. Unlike power amplifiers, and especially power amplifiers with feed-forward architectures, the spectral regrowth internal to the spectrum analyzer can easily be approximated with simple algebra. The analysis of spectral regrowth generated by spectrum analyzer intermodulation distortion relies on the premise that when the power at the input mixer is far below gain compression power level (by at least 15 dB), the spectrum analyzer behaves as a weakly-nonlinear device. Such a device has a voltage-in to voltage-out transfer function given by the power series:  $V_o = a_1V_i + a_2V_i^2 + a_3V_i^3 + \dots + a_nV_i^n$ . For spectrum analyzer front ends, the power series does an excellent job of predicting the frequencies of the intermodulation distortion terms and their relative amplitudes. As the input power approaches the spectrum analyzer gain compression level, the power series approximation no longer hold true, indicating the limitation of this equation to relatively low power levels.

Spectral regrowth modeling for the spectrum analyzer front end begins by breaking up the main channel into a series of equal spaced divisions in the frequency domain. Each division is represented by a CW tone whose power is the same as the total power in that particular division. Figure 3-3a depicts this interpretation of

**Figure 3-3a**  
Spectral Regrowth Generated Within the Spectrum Analyzer can be Modeled by Treating the Digital Signal as a Series of CW Tones

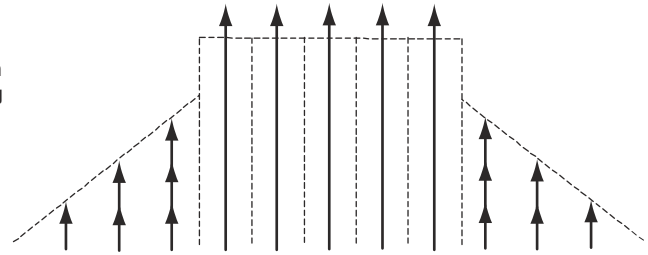

**Figure 3-3b**  
Spectral Regrowth as Displayed on the Log Scale

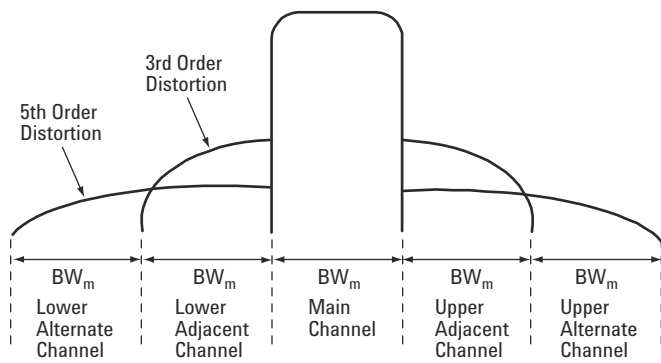

the spectral regrowth model. Each CW tone representing a segment of the main channel interacts with all of the other CW tones creating intermodulation distortion products. Intermodulation products resulting from different tones start combining with each other, with the most products adding at the edges of the main channel. It has been determined empirically that the individual distortion products add as voltages using the  $20 \text{ Log}(\ )$  relationship. In most cases a log amplitude scale is used that displays the spectral

regrowth falling off on a curve as shown in Figure 3-3b. For third order distortion, the upper and lower spectral regrowth bandwidths are only as wide as the modulation bandwidth of the digitally modulated signal. The third order distortion extends out in frequency away from the main channel by one modulation bandwidth and fifth order extends by two modulation bandwidths. Third order distortion dominates in adjacent channel measurements. For alternate channel measurements, fifth order distortion becomes a concern.

Spectral regrowth due to intermodulation distortion is noise-like, implying that the main signal power to spectral regrowth power ratio is independent of the spectrum analyzer RBW setting. In other words, the displayed main channel PSD and the spectral regrowth PSD both vary by the  $10 \times \text{Log}(\text{RBW})$  relation. Another implication is that when the distortion approaches the system noise floor, the distortion and noise add as uncorrelated powers using the relationship:

$$\text{Total Power} = 10 \times \text{Log}(10^{\text{Noise Power} / 10} + 10^{\text{Distortion Power} / 10}) \text{ dBm} \quad (3-1)$$

where Noise Power is the system noise in dBm and Distortion Power is the intermod-generated spectral regrowth in dBm.

Calculating the level of third order generated spectral regrowth depends on the frequency offset from the main channel center frequency and the peak-to-average-ratio of the signal. A further complication is whether or not the adjacent channel measurement is made at fixed offset frequencies, as with IS-95 CDMA, or the measurement, is an integrated power measurement as with W-CDMA. For measurements at fixed offset frequencies, Figure 3-4 can be used to estimate the third order spectral regrowth for the PSA series analyzer. Note that these results cannot be generalized for other spectrum analyzers. Shown is the TOI offset from the two-tone TOI performance of the spectrum analyzer versus the frequency offset from the center of the main channel for three different peak-to-average ratios.

**Figure 3-4**  
Effective TOI of Digitally Modulated Signal versus Frequency Offset from Main Channel

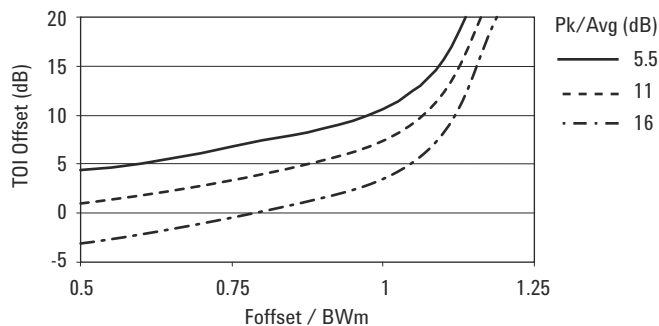

The best way to show how to use Figure 3-4 is through illustration. Suppose the ACPR is to be calculated at an offset of 885 kHz for an IS-95 CDMA signal whose modulation bandwidth is 1.23 MHz and peak-to-average ratio is 11 dB. The  $F_{\text{offset}}/BW_m$  ratio =  $.885/1.23 = 0.72$ . From Figure 3-4, the TOI offset at  $F_{\text{offset}}/BW_m$  of 0.72 is +3 dB. Suppose the spectrum analyzer has a two tone TOI of +20 dBm, the effective TOI at 885 kHz offset would be 20 dBm + 3 dB or +23 dBm. If the power at the spectrum analyzer's input mixer is -10 dBm, the spectral regrowth can be calculated by manipulating the equation:  $\text{TOI} = P + \Delta/2$ . In this case,  $\Delta$  is the dB difference of the main channel PSD to the third order spectral regrowth. For the example in this discussion, this power difference is computed as

$$\begin{aligned} \Delta &= 2 \times (\text{TOI} - P) \\ \Delta &= 2 \times (23 - (-10)) \\ \Delta &= 66 \text{ dB} \end{aligned}$$

So at an offset of 885 kHz from the main channel center frequency, the third order spectral regrowth generated within the spectrum analyzer would be 66 dB below the main channel average PSD.

For measurements that rely on an integrated power measurement across the adjacent channel, predicting the level of spectral regrowth due to third order distortion depends on modulation bandwidth and channel spacing. Channel spacing is important because it determines the unused frequency band between channels, where the spectral regrowth can be ignored. W-CDMA is one important class of digitally modulated signals that use an integrated measurement.

For W-CDMA with 3.84 MHz symbol rate and a 5 MHz channel spacing, the effective TOI offset is given in Table 3-1.

This table shows how to calculate the integrated adjacent channel power due to third order distortion. For example, suppose the W-CDMA signal has a peak-to-average ratio of 11 dB and the spectrum analyzer has a two-tone TOI of +20 dBm. The effective TOI with a W-CDMA modulated signal is 20 dBm + 4 dB or +24 dBm. Manipulating the math as in the previous example, the spectral regrowth in the adjacent channel, assuming -10 dBm power at the input mixer, is:

$$\Delta = 2 \times (24 - (-10))$$

$$\Delta = 68 \text{ dB}$$

That is, the power integrated across the adjacent channel is 68 dB below the power integrated across the main channel.

**Table 3-1.**  
Effective TOI Offset  
for W-CDMA

Pk/Avg (dB)	TOI Offset (dB)
5.5	7.5
11	4
14.5	2

**Figure 3-5**  
Phase Noise  
Contribution of a  
Digitally Modulated  
Signal

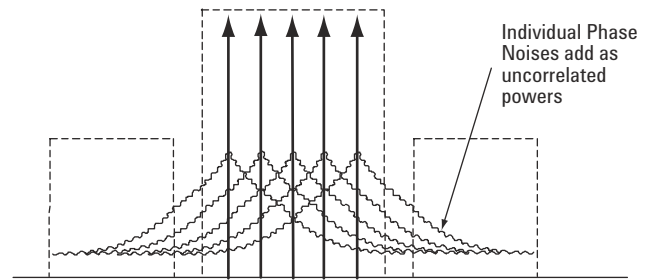

### Phase Noise Contribution

Just as internally generated phase noise can limit the dynamic range when measuring CW tones, phase noise also places a limitation on the dynamic range when measuring digitally modulated signals. The model used to calculate intermodulation distortion of a digitally modulated signal also proves useful in showing how the phase noise adds to the spectral regrowth in the adjacent channel. In Figure 3-5, the main channel is divided into segments of equal frequency width with a CW tone representing the power in each segment.

Associated with each CW tone is a phase noise skirt. The phase noise power contributed by individual tones at any given frequency add in an uncorrelated fashion (that is, the  $10 \text{ Log}(\ )$  relationship). The closer the frequency offset is to the main channel, the greater the summation of the phase noise power. The end result is a reduction in the phase

noise dynamic range of roughly  $10 \times \text{Log}(\text{BW}_m)$ . For example, suppose at 100 kHz offset, the spectrum analyzer's specified phase noise is -118 dBc/Hz. With a modulation bandwidth of 1.23 MHz, the phase noise power at 100 kHz away from the edge of the main channel relative to the PSD of the main channel would be  $-118 + 10 \times \text{Log}(1.23 \times 10^6) + 0.25 = -56.85 \text{ dB}$  (the 0.25 dB term is the  $10 \times \text{Log}(\text{NBW}/\text{RBW})$  discussed earlier). This relative phase noise power is not exact, because at any given frequency outside of the main channel, the phase noise derives from contributors that span the width of the main channel. Therefore, use the  $10 \times \text{Log}(\text{BW}_m)$  as a first order guide and that is probably within a couple dB of the true phase noise. From the depiction in Figure 3-5, for narrowly spaced channels, the phase noise can be a serious limitation for ACPR measurements.

## Dynamic Range Chart for Digitally Modulated Signals

We now have all the ingredients to create the dynamic range chart when making distortion measurements on digitally modulated signals.

Remember, the goal is to determine the optimum input power at the mixer, which is a natural outcome of the dynamic range chart.

Unfortunately, the dynamic range chart for digitally modulated signals is highly format dependent.

Parameters such as modulation bandwidth and channel spacing—whether or not the ACPR measurement is at fixed offset frequencies or is an integrated power measurement—and the peak-to-average ratio of the main channel signal all affect the formation of the dynamic range chart. While it is impossible to generalize the dynamic range chart, we can get a feel for the considerations involved in constructing a suitable dynamic range chart by showing a couple of specific examples.

Figure 3-6 shows the dynamic range chart for IS-95 CDMA with an 11 dB peak-to-average ratio measured at a single offset frequency of 885 kHz. The parameters used to construct this chart are: modulation bandwidth = 1.23 MHz, DANL = -155 dBm/Hz, TOI = 20 dBm + 3 dB offset to account for the 11 dB peak-to-average ratio, Fifth Order Intercept = +12 dBm, and phase noise = -132 dBc/Hz at an offset of 270 kHz.

**Figure 3-6**  
Dynamic Range Chart for IS-95 CDMA at 885 kHz Offset

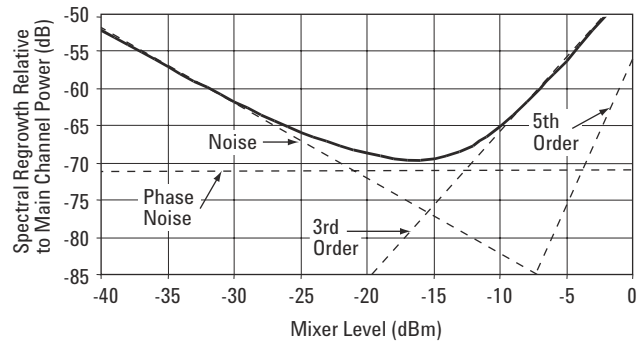

**Figure 3-7**  
Dynamic Range Chart for W-CDMA

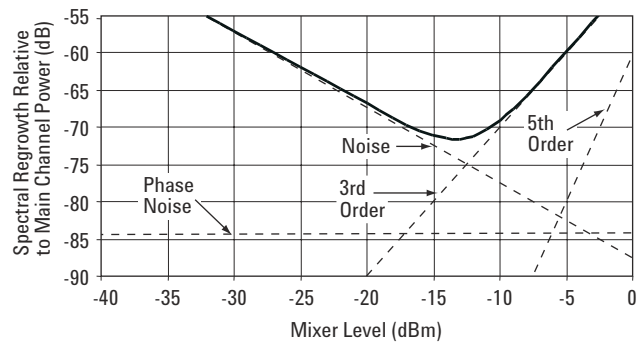

The frequency offset value used to approximate the phase noise results from the following computation: the half-bandwidth of the measurement channel is  $(1.23 \text{ MHz} / 2)$ , or 615 kHz. At a measurement frequency 885 kHz away from the center of the main channel, the frequency difference between the measurement frequency and the edge of the main channel is 885 kHz minus 615 kHz, or 270 kHz.

A few observations can be made regarding Figure 3-6. First, because the measurement frequency is only 270 kHz away from the edge of the main channel, phase noise is the limiting mechanism for dynamic range. Fifth order intermodulation distortion is negligible. Third order intermodulation distortion and broadband noise are minor contributors in the region of maximum dynamic range. The optimum mixer level is nearly 20 dB higher than the mixer level for the two-tone intermodulation distortion shown in Figure 2-10.

Figure 3-7 shows the dynamic range chart for W-CDMA. Again, the peak-to-average ratio for the signal is 11 dB. The measurement uses integrated power across both the main and the adjacent channel as opposed to the single frequency measurement for IS-95 CDMA. The parameters used to construct this chart are: symbol rate = 3.84 MHz, channel spacing = 5 MHz, DANL = -155 dBm/Hz, TOI = 21 dBm + 4 dB offset to account for the 11 dB peak-to-average ratio, Fifth Order Intercept = +12 dBm, and phase noise = -150 dBc/Hz at an offset of 1.17 MHz. The frequency offset used to estimate the phase noise contribution results from the fact that the frequency difference between the edge of the main channel and the edge of the adjacent channel is 1.17 MHz.

Because of the 1.17 MHz spacing between channel edges, the phase noise is considerably lower than with the IS-95 CDMA example. In fact, phase noise is not a significant contributor at all. In the region of maximum dynamic range, fifth order intermodulation distortion is also not a significant contributor. Third order intermodulation distortion

spectral regrowth and broadband noise are the only limitations in the region of highest dynamic range. Notice that the range of mixer levels where the dynamic range is maximized is narrower than for the IS-95 CDMA case. Optimum mixer level is about -13 dBm.

Figure 3-7 can also be used to interpret the optimum mixer level for the alternate channel power measurement. In the alternate channel, as depicted in Figure 3-3b, the third order distortion products do not exist, leaving only the fifth order distortion contributing to intermodulation generated spectral regrowth. For the PSA series, phase noise power stays at a near constant value between 1 and 6 MHz offsets. Thus the phase noise curve in Figure 3-7 used for the adjacent channel applies with little error for the alternate channel measurement. For this measurement the optimum mixer level is about -5 dBm.

### **Measurement Error Due to SA Spectral Regrowth Adding to DUT Spectral Regrowth**

For CW distortion, we demonstrated that to reduce the measurement error, the DUT and spectrum analyzer distortion product levels must be offset by an amount dictated by the desired measurement error. For digitally modulated signals, a similar consideration must be taken into account. In the case of digitally modulated signals, the level of intermodulation generated spectral regrowth of the spectrum analyzer must be below the DUT spectral regrowth by a calculated amount.

When the amplitude of the DUT's spectral regrowth falls near the spectral regrowth generated within the spectrum analyzer, the two add in a manner dependent on the characteristics of the modulation format. For extremely low peak-to-average ratios, the distortion products add, approximately, as uncorrelated powers. As the peak-to-average ratio increases, the spectral regrowth levels of the DUT and the SA add in a fashion

consistent with the power addition of correlated signals. The conservative approach would be to use equation 2-7 to estimate differences in DUT and SA spectral regrowth levels as a function of the desired amount of measurement uncertainty. Once the desired spectral regrowth level difference is calculated, the information can be applied to the dynamic range charts to estimate the measurement dynamic range and the corresponding mixer level. Using the example in Part II where less than 1 dB of distortion related error was desired, we apply the same +18.3 dB y-axis offsets to the third and fifth order curves in the dynamic range charts for digitally modulated signals. For the IS-95 example where phase noise mostly limits the ACPR measurement, the effect of offsetting the third order curve is not very significant to the overall ACPR dynamic range. But for the W-CDMA example, where S/N and third order distortion limit the ACPR dynamic range, offsetting the third order curve has the same effect on dynamic range as with the CW example where dynamic range is reduced by 6.1 dB and the optimum mixer level is shifted 9.2 dB lower.

## Part IV: PSA Architectural Effects on Distortion Measurements

In Parts II and III we demonstrated that in order to maximize the dynamic range of the spectrum analyzer, the power at the input mixer must be optimized. Now in Part IV we begin discussing some block diagram characteristics specific to the PSA series that may prove useful in achieving the optimum mixer level.

### Input Attenuator Resolution

Unless the mixer level can be optimally set, the full dynamic range performance of the spectrum analyzer cannot be achieved. Controlling the Input Attenuator provides an easy, and a very accurate, means of controlling the power at the input mixer. If the step resolution of the Input Attenuator is too coarse, then setting the optimum mixer level may prove to be very difficult. Figure 4-1 shows the limitation of the achievable dynamic range due to the resolution of the Input Attenuator.

If the Input Attenuator is adjusted too high in value, broadband spectrum analyzer noise limits the achievable dynamic range and if the Input Attenuator is adjusted too low in value, internally generated distortion limits the dynamic range. Figure 4-1 depicts the worst case situation where dynamic range is equally limited by noise or distortion as the Input Attenuator toggles between two adjacent settings. One may get lucky and a particular attenuation setting may allow an optimal setting for the mixer level, but in general this luck cannot be relied upon. The potential dynamic range given up is the difference between the maximum dynamic range and the achievable dynamic range in the worst case scenario. Clearly, a finer resolution in the input attenuator allows more control of the power at the input mixer, which in turn minimizes the dynamic range that is given up.

**Figure 4-1**  
**Attenuator Step Size Governs the Ability to Achieve the Optimum Mixer Level**

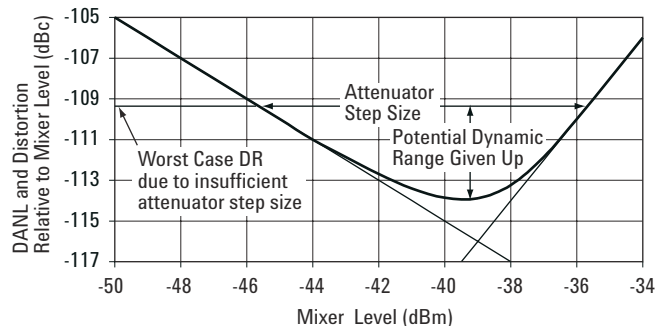

If one takes the simplistic view that maximum dynamic range occurs at the intersection of the noise and the distortion product curves, then the dynamic range given up can be substantial unless a very fine resolution of the Input Attenuator step size is used. However, as indicated earlier, when the distortion amplitude approaches the noise floor, the noise and distortion add giving a curve that is more of a trough where the maximum dynamic range occurs. In this case the sensitivity of achievable dynamic range versus attenuator step size is not nearly as great as in the simplistic view.

Table 4-1 summarizes the dynamic range given up versus attenuator step size for three scenarios: the simplistic view where noise and distortion curves meet at a point, CW type distortion on the Log-Power (Video) averaging scale, and noise-like distortion on the Power (RMS) averaging scale where the noise

and distortion add as uncorrelated powers. With the simplistic view, one is led to believe that even finer than 1 dB input attenuator resolution is warranted in order to minimize the lost dynamic range. However, for the more realistic cases where noise adds to the near-noise distortion products, the dynamic range given up is not nearly as great.

The PSA series offer an Input Attenuator with a 2 dB step size. This allows the user to fine tune the mixer level so that in the worst case, only 0.28 dB of potential dynamic range is given up. One could use external fixed attenuators to achieve the same results as the internal step attenuator. However, convenience is certainly sacrificed and, more importantly, so is accuracy. External attenuators lack the frequency response calibration that is assured when using the Input Attenuator of the PSA series analyzers.

**Table 4-1.**  
**Potential Dynamic Range Given up [dB]**  
**versus Attenuator Step Size [dB].**

Attenuator Step Size (dB)	Simplistic View	CW distortion adding to noise on the Log-Power scale	Noise-like distortion adding to noise on the Power scale
10	6.7	4.7	4.1
5	3.3	1.6	1.3
2	1.3	.28	.23
1	.67	.08	.06

## Internal Filtering

Although knowing the internal architecture of the spectrum analyzer seems an unnecessary burden, some simple concepts such as the internal filters may help in achieving more dynamic range performance when making distortion measurements.

Figure 4-2 shows a highly simplified block diagram of the PSA series front end.

Two paths exist: lowband for tuned frequencies less than 3 GHz and highband for tuned frequencies from 3 to 26.5 GHz. Lowband path is broadband in that all signals that fall below 3 GHz are present at the input of the lowband mixer. Highband path, by contrast, uses a tuning preselector filter whose 3 dB bandwidth varies from 40 MHz at 3 GHz to more than 80 MHz at 26.5 GHz.

When measuring harmonic distortion, there is a clear demarcation for fundamental frequencies whose harmonics fall above and below 3 GHz. For harmonics that fall below 3 GHz, the lowband first mixer contributes its internally generated distortion to the measurement. However, once the distortion frequency falls above 3 GHz, the highband path's preselector greatly attenuates the fundamental tone power before it can reach the highband mixer. The PSA series specification sheet shows that the SHI performance makes a dramatic improvement for source frequencies above 1.5 GHz.

**Figure 4-2**  
**PSA Series**  
**Front End**

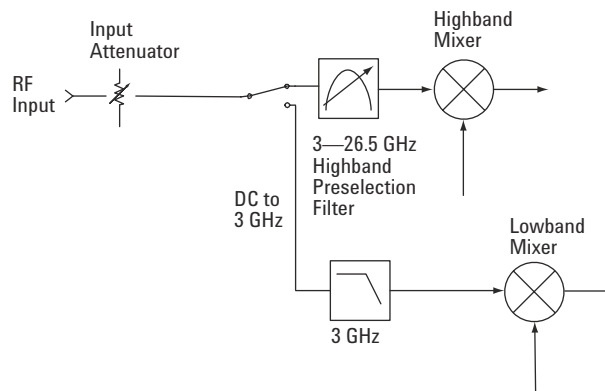

One should also be aware of the potential of overloading the front end when the lowband path is selected. The PSA series specify a gain compression level that is the total power at the input mixer at which the gain of the spectrum analyzer drops by 1 dB. That is, if the power at the input mixer is at the gain compression level, spectral components of the displayed signal could be as much as 1 dB lower than when the mixer level is less than -10 dBm. This is important when working in a multi-tone environment and the frequency span of the spectrum analyzer is sufficiently narrow to remove large signals from view. For the highband path, knowledge of the preselector bandwidth can help extend the gain compression performance of the spectrum analyzer. The PSA series specification for gain compression in highband is for the power at the mixer. As the analyzer tunes away from a particularly strong signal, the preselector filter

will attenuate this signal before it reaches the highband mixer. So in a multi-tone environment, if the spectrum analyzer is tuned several preselector bandwidths away from a strong signal, we can reduce the input attenuation, thus improving dynamic range without worrying about front end compression affecting the amplitude accuracy of the measurement.

One last item regarding internal filtering is the filtering in the final IF of the PSA series. This discussion assumes that the PSA series analyzer is in swept analysis mode as opposed to FFT analysis mode. Swept analysis mode is selected by activating the Mode Setup hardkey, FFT & Sweep softkey, Sweep Type set to Swp. The maximum mixer level before the final IF overloads is within 2 dB above -10 dBm. In fact, the user cannot set the reference level such that the mixer level is above -10 dBm. Signals above this level are displayed above the top of the screen and a 'Final IF Overload' message appears on the display. However, the specified gain compression level is more than 10 dB



above this level, which can yield 10 dB more compression-to-noise dynamic range out of the spectrum analyzer over what is at first apparent. When measuring a small signal in the presence of a large signal, first measure the amplitude of the large signal with sufficient input attenuation to drop the mixer level below -10 dBm. When measuring the small signal, tune the start and stop frequency such that the large signal is at least 15 kHz or 15 x RBW setting (whichever is greater) outside of the frequency range of the spectrum analyzer. For example, if a large signal is present at 1 GHz and the user wants to measure a small signal above 1 GHz and a 1MHz RBW setting is selected, ensure that the start frequency of the spectrum analyzer is greater than 1.015 GHz (1 GHz + 15 x 1 MHz). Once the frequency span is set such that the large signal is no longer in view, the Input Attenuator can be adjusted lower to improve the measurement sensitivity. However, care must be observed when lowering the Input Attenuation so that the power at the mixer is still below the specified compression level.

**Figure 4-3**  
Dynamic Range Chart with the Internal Preamp Selected

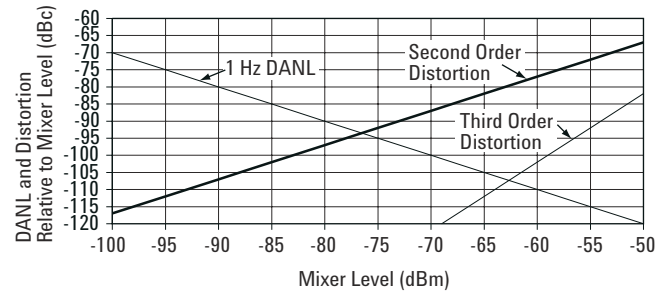

### Internal Preamplifier

The PSA series offer an internal lowband 100 kHz–3GHz preamplifier as an option (Option 1DS). The preamplifier is placed in the block diagram after the input attenuator, but before the lowband input mixer. The preamplifier places roughly 28 dB of gain ahead of the lowband first mixer, which lowers the system DANL by about 15 dB. Normally, the preamplifier is used to measure extremely low amplitude spurious signals, signals that would normally fall close to or below the noise floor in the non-preamplifier path. However, it is worth mentioning the behavior of the preamplifier path if this path is selected when making distortion measurements.

As previously mentioned, the preamplifier lowers the noise floor of the spectrum analyzer by about 15 dB. The preamplifier does not significantly add distortion to the system, however it does increase the power at the input mixer by the nominal gain value of 28 dB. This has the effect of lowering system SHI, TOI, and gain compression level by around 28 dB. The result is a drop in the second order dynamic range of 6.5 dB, a drop in the third order dynamic range of 8.5 dB, and a drop in the compression to noise dynamic range of 13 dB.

Figure 4-3 shows the dynamic range chart for the internal preamplifier path selected. For both second order dynamic range and third order dynamic range, the optimum mixer levels are considerably lower than with the non-preamplifier path. This may be of some benefit for low level applications where there is not enough DUT power to reach the optimum mixer level of the non-preamplifier path.

## Part V: Enhancing Distortion Measurements

In this final Part, we cover a few miscellaneous items that could impact the distortion measurement.

### Reducing Source Intermodulation Distortion

Equally as important as ensuring proper configuration of the spectrum analyzer used to measure intermodulation distortion is that the sources used to generate the multi-tone stimulus be free of IMD. IMD generated in the sources is normally a result of insufficient isolation between the sources. Figure 5-1 shows a highly simplified block diagram of a signal source.

The signal source generates the CW tone at frequency  $f_1$ . A second CW source at frequency  $f_2$  is connected to this signal source by some means of power combination. Signal energy from the second source enters the output port of the source and, because the output coupler does not have infinite isolation, a portion of the  $f_2$  signal leaks into the coupled port of the output coupler. Both the signals at  $f_1$  and  $f_2$  are detected, which creates a beat note at a frequency of  $|f_2 - f_1|$ . If this beat note is lower in frequency than the loop bandwidth of the automatic leveling control (ALC) circuit, the ALC will respond to this signal causing AM sidebands on the output signal. Unfortunately, the AM sidebands fall right at the intermodulation distortion product frequencies, resulting in what appears as IMD out of the source.

**Figure 5-1**  
Simplified Output  
Section of a Signal  
Generator

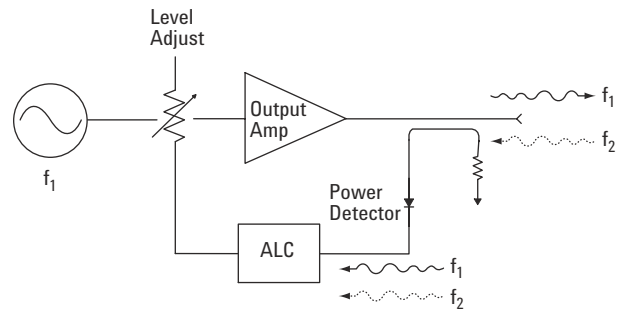

The solution to improving source generated IMD is to prevent the energy of the second source signal from entering the output port of the signal source. The required isolation between the two sources is dependent on the susceptibility of the signal source to signals entering the output port as well as the acceptable AM sideband level needed for the TOI measurement.

Some of the better power combination techniques are:  
Wilkinson Power Combiners—these can achieve greater than 30 dB isolation.

Class A Amplifiers at the output of the sources—important to not use amplifiers that have leveling control circuitry of their own.

Fixed Attenuators—these should be used in conjunction with power splitters and amplifiers.

Isolators—the downside is their relatively narrow bandwidth.

Couplers—high directivity couplers needed.

Some power combiners that do not work very well are two- and three-resistor splitters. The temptation to use these are great due to their very wide bandwidth. However the two-resistor splitter only has 12 dB of isolation and the three-resistor splitter only has 6 dB of isolation. A device that should never be used is the T (BNC T and smb T are examples). These not only have zero isolation, but also they present a very poor match to the DUT, which can have an adverse effect on the measurement accuracy.

## Effects of Harmonics on Intermodulation Distortion

When measuring intermodulation distortion, an important consideration is the harmonic content from the sources as well as the device under test. Two-tone IMD will be used in the following example, however this analysis can be extrapolated to multi-tone IMD.

Suppose a nonlinear device, either the DUT or the spectrum analyzer used to make the IMD measurement,

can be modeled using the power series up through the third order term:

$$V_o = a_1V_i + a_2V_i^2 + a_3V_i^3 \quad (5-1)$$

Now subject this nonlinear device to the following two-tone input signal:

$$V_i = A \times \text{Cos}(\omega_1t) + B \times \text{Cos}(\omega_2t) + C \times \text{Cos}(2\omega_1t) \quad (5-2)$$

For a two-tone IMD measurement, amplitudes A and B are set to be the same. The third term represents the second harmonic of the first term. Inserting the input voltage into the model of the nonlinear device, performing the trigonometric expansions and collecting terms, the low side IMD product is given by:

$$V_o = [(3/4)a_3A^2B + a_2BC] \times \text{Cos}((2\omega_2 - \omega_1)t) \quad (5-3)$$

Clearly, the second harmonic of the term at  $2\omega_1$  contributes to the intermodulation distortion product. In fact, depending on the phase of the second harmonic distortion term, the second harmonic can add constructively or destructively to the IMD term.

For a two-tone measurement setup as shown in Figure 1-3, the second harmonic can originate from either the sources themselves, the device under test, or the spectrum analyzer used to make the IMD measurement. Evidence of second harmonic interference is asymmetry in the amplitudes of the low side and high side IMD products; this is especially true if one of the sources has worse harmonic performance than the other source. Another clear sign is IMD, which varies widely across a narrow frequency range.

The obvious solution to a suspected harmonic interference problem is to place filters in the measurement setup. Filtering in front of the DUT will reduce harmonic content due to the sources, and filtering after the DUT will reduce the harmonic interference generated by the DUT itself.

However, caution must be exercised when placing filters in the measurement system. Being reflective in the stopband, the filters can contribute to some unexpected results in the IMD measurement. If the DUT is an amplifier, it may be driven into an unstable state if filters are placed at either the input or the output ports. For DUTs such as mixers, poor match at image and spurious frequencies can make the DUT IMD worse than if no filters were used at all. Placing fixed value attenuators between the DUT and the filters can mitigate the effects of the poor stopband matches—if the system can tolerate the power loss.

## Noise Subtraction Techniques

Noise subtraction is the process of mathematically removing the system noise of the spectrum analyzer from displayed signals, thus improving the apparent signal-to-noise ratio of the measurement. This technique is especially powerful for signals that fall within a few dB of the displayed noise floor. In reference [4], the mathematical justification for noise subtraction and the measurement requirements under which noise subtraction is valid are presented. Here we will show a couple of distortion measurement examples where noise subtraction can be used.

As stated in reference [4], the signal power,  $power_s$ , can be derived from:

$$power_s = power_{s+n} - power_n \text{ [mW]} \quad (5-4)$$

where  $power_{s+n}$  is the displayed signal plus noise power and

$power_n$  is the spectrum analyzer's noise floor measured with the signal disconnected from the input of the spectrum analyzer. All powers are in linear power units such as mW.

The caveat is that the measurement be carried out using power detection, that is, the averaging scale on the PSA series analyzer should be set to Power (RMS). This stipulation must be observed for CW signals that are normally measured with the Log-Power (Video) averaging scale selected.

The procedure for performing the noise subtraction on the PSA series analyzer is as follows:

1. Set the Detector Mode to Average Detector.  
Set the Avg/VBW Type to Pwr Avg (RMS)  
Set the Input Attenuator, RBW, VBW appropriately for the distortion measurement.
2. Remove the signal from the analyzer input. For even more accuracy, the RF input can be terminated in 50 Ohms. Slow the sweep time in order to reduce the variance of the noise signal. Read in the trace data to an external computer; this is the noise power data.
3. Connect the signal to the analyzer input. Read in the trace data. Avoid changing the RBW, VBW, Input Attenuator or Sweep speed settings from the settings in step 2. Read in the trace data to an external computer; this is the signal plus noise power data.
4. In the external computer, convert the log measurements to linear values, perform the subtraction of equation 5-4 on a point by point basis. Convert the result to convenient units, such as dBm.

Subtracting the linear power noise data from the linear power signal-plus-noise data can result in negative power values, which cause an illegal operation when mathematically converting the resultant value back to log power. One can set these negative values to an arbitrarily small linear value to avoid the mathematical anomaly. However, if an integrated channel power measurement is to be performed it is best to leave the negative linear power values intact, add all the linear trace data points across the channel, and then convert the integrated channel power back to a log power value. Otherwise, the effect of discarding negative results will increase the computed average power.

There is a relationship between the amount of noise that can be cancelled and the variance of the measured data. Lower variance using averaging or longer sweep times with the average detector activated results in more noise cancellation. One can expect about a 10 dB improvement in the amount of noise that can be reliably cancelled.

Figure 5-2 shows the results of noise subtraction on a CW signal. The upper trace shows the displayed signal using the Power display scale. It shows a displayed signal to noise ratio of 4 dB. The lower trace shows the noise subtracted. One observation is that the signal no longer contains the noise error, which in this case is 2 dB. Also note that the noise floor drops by at least 10 dB. In this particular example, the sweep times for both the noise and the signal plus noise measurements are 45 seconds.

Figure 5-3 shows noise subtraction performed on a W-CDMA signal. The upper trace shows that the noise floor of the PSA series analyzer limits the dynamic range of the measurement in the adjacent channel. The lower trace shows the result of noise subtraction. This trace clearly shows the third order distortion component of the spectral regrowth in the adjacent channel. Without noise subtraction, the noise floor of the spectrum analyzer limits the dynamic range. However, with noise subtraction, the third order distortion generated within the spectrum analyzer limits the dynamic range. One could improve the measurement by reducing the signal power in order to drive down the third order distortion. The sweep times for this example are 120 seconds for both the noise and the signal-plus-noise measurements.

**Figure 5-2**  
**CW Signal with**  
**and without**  
**Noise Subtraction**

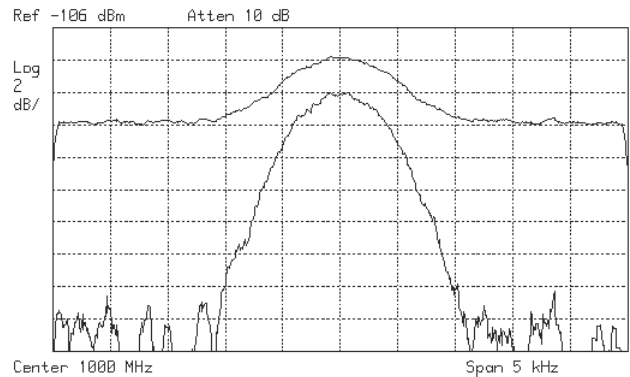

**Figure 5-3**  
**W-CDMA Signal**  
**with and without**  
**Noise Subtraction**

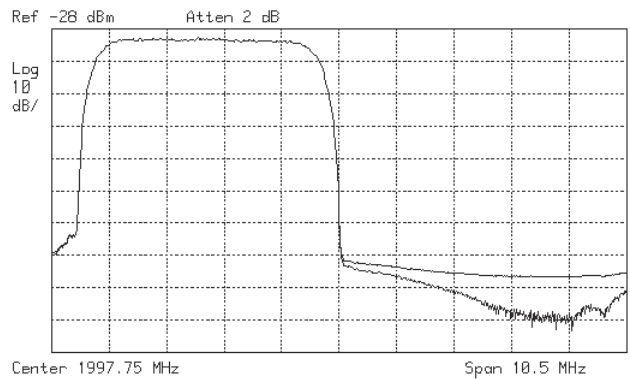

## Conclusions

One of the primary uses of the spectrum analyzer is for making distortion measurements. This product note has served as both an introductory tutorial on distortion measurements and as a guide to making these measurements accurately using a PSA series analyzer. Not only has the reader been introduced to properly configuring the PSA spectrum analyzer for optimum dynamic range performance, but also some of the measurement errors as well as guidelines on reducing measurement error have been presented.

## Glossary of Terms

### **ACPR**

Adjacent Channel Power Ratio = Adjacent channel power in dBm minus Main channel power in dBm. Units are dB.

### **CW**

Carrier Wave or Continuous Wave. A sinusoidal signal without modulation.

### **DANL**

Displayed Average Noise Level. The noise floor as it appears on the display of the spectrum analyzer.

### **dBc**

dB relative to the carrier

### **dBm**

dB relative to 1 mWatt

### **IMD**

Intermodulation Distortion

### **Log-Power (Video)**

The default averaging scale for measuring CW type distortion.

### **Max Mxr Lvl**

Maximum Mixer Level. Reference Level and Input Attenuator are automatically coupled such that, when an input signal amplitude is at the highest vertical display division, the power at the input mixer is no higher than the Max Mxr Lvl value.

### **Mixer Level**

Power at the input mixer. Equals the RF Input power minus the nominal Input Attenuator value.

### **NBW**

Noise Power Bandwidth. The bandwidth of a fictional rectangular bandpass filter that passes the same amount of white noise power as does the RBW filter. For the PSA series,  $NBW/RBW = 1.06$

**Power (RMS)** The averaging scale in which effects of log scale processing on displayed noise are removed.

### **RBW**

Resolution Bandwidth Filter. This IF filter is placed before the envelope detector. Reducing its bandwidth improves the selectivity of closely spaced signals as well as lowers the displayed noise floor.

### **RMS**

Root Mean Square. Noise measured on the power scale is reported in RMS notation, which removes the -2.51 dB offset due to log display processing.

### **SHI**

Second Harmonic Intercept. A figure of merit for second harmonic distortion.

### **S/D**

Signal-to-Distortion Ratio. Units are dB.

### **S/N**

Signal-to-Noise Ratio. Units are dB.

### **TOI**

Third Order Intercept. A figure of merit for third order intermodulation distortion.

### **VBW**

Video Bandwidth Filter. This filter is placed after the envelope detector. Reducing its bandwidth reduces the variability of the displayed signal.

## References

- [1] *Spectrum Analyzer Basics*, Agilent Technologies Application Note 150, literature number 5952-0292, November, 1989.
- [2] Witte, Robert A., *Spectrum and Network Measurements*, Prentice Hall, Inc., 1993.
- [3] *Using a Network Analyzer to Characterize High Power Components*, Agilent Technologies Application Note 1287-6, literature number 5966-3319E, 1998.
- [4] *Spectrum Analyzer Measurements and Noise*, Agilent Technologies Application Note 1303, literature number 5966-4008E, 1998.
- [5] Maas, S. A., *Third Order Intermodulation Distortion in Cascaded Stages*, IEEE Microwaves and Guided Waves Letters, Vol. 5, No. 6, June 1995, pg. 189-191.
- [6] Mouthrup, Andrew A. and Muha, Michael S., *Accurate Measurement of Signals Close to the Noise Floor of a Spectrum Analyzer*, IEEE Transactions on Microwave Theory and Techniques, Vol. 39, No. 11, November 1991, pg. 1882 - 1885.

## Related Literature for the Agilent PSA Performance Spectrum Analyzer Series

### *The Next Generation*

Brochure

literature number 5980-1283E

### *E4440A PSA*

*Spectrum Analyzer Series*

Technical Specifications

literature number 5980-1284E

### *Amplitude Accuracy*

Product Note

literature number 5980-3080EN

### *Measurement Innovations and Benefits*

Product Note

literature number 5980-3082EN

### *Select the Right PSA Spectrum Analyzer for Your Needs*

Selection Guide

literature number 5968-3413E

### *Self-Guided Demonstration*

Product Note

literature number 5988-0735EN

### *Swept and FFT Analysis*

Product Note

literature number 5980-3081EN

## Warranty

The E4440A is supplied with a 3 year warranty.

Visit our web site at:

[www.agilent.com/find/psa](http://www.agilent.com/find/psa)

## Agilent Technologies' Test and Measurement Support, Services, and Assistance

Agilent Technologies aims to maximize the value you receive, while minimizing your risk and problems. We strive to ensure that you get the test and measurement capabilities you paid for and obtain the support you need. Our extensive support resources and services can help you choose the right Agilent products for your applications and apply them successfully. Every instrument and system we sell has a global warranty. Support is available for at least five years beyond the production life of the product. Two concepts underlie Agilent's overall support policy: "Our Promise" and "Your Advantage."

### Our Promise

Our Promise means your Agilent test and measurement equipment will meet its advertised performance and functionality. When you are choosing new equipment, we will help you with product information, including realistic performance specifications and practical recommendations from experienced test engineers. When you use Agilent equipment, we can verify that it works properly, help with product operation, and provide basic measurement assistance for the use of specified capabilities, at no extra cost upon request. Many self-help tools are available.

### Your Advantage

Your Advantage means that Agilent offers a wide range of additional expert test and measurement services, which you can purchase according to your unique technical and business needs. Solve problems efficiently and gain a competitive edge by contracting with us for calibration, extra-cost upgrades, out-of-warranty repairs, and on-site education and training, as well as design, system integration, project management, and other professional engineering services. Experienced Agilent engineers and technicians worldwide can help you maximize your productivity, optimize the return on investment of your Agilent instruments and systems, and obtain dependable measurement accuracy for the life of those products.

### By internet, phone, or fax, get assistance with all your test & measurement needs

#### Online assistance:

[www.agilent.com/find/assist](http://www.agilent.com/find/assist)

#### Phone or Fax

**United States:**  
(tel) 1 800 452 4844

**Latin America:**  
(tel) (305) 269 7500  
(fax) (305) 269 7599

**Canada:**  
(tel) 1 877 894 4414  
(fax) (905) 282 6495

**Australia:**  
(tel) 1 800 629 485  
(fax) (61 3) 9210 5947

**Europe:**  
(tel) (31 20) 547 2323  
(fax) (31 20) 547 2390

**New Zealand:**  
(tel) 0 800 738 378  
(fax) 64 4 495 8950

**Japan:**  
(tel) (81) 426 56 7832  
(fax) (81) 426 56 7840

**Asia Pacific:**  
(tel) (852) 3197 7777  
(fax) (852) 2506 9284

Product specifications and descriptions in this document subject to change without notice.  
Copyright © 2000 Agilent Technologies  
Printed in U.S.A. November 28, 2000  
5980-3079EN



**Agilent Technologies**

Innovating the HP Way