

Keysight Technologies

Impedance Measurement Handbook

A guide to measurement technology and techniques

4th Edition

Application Note

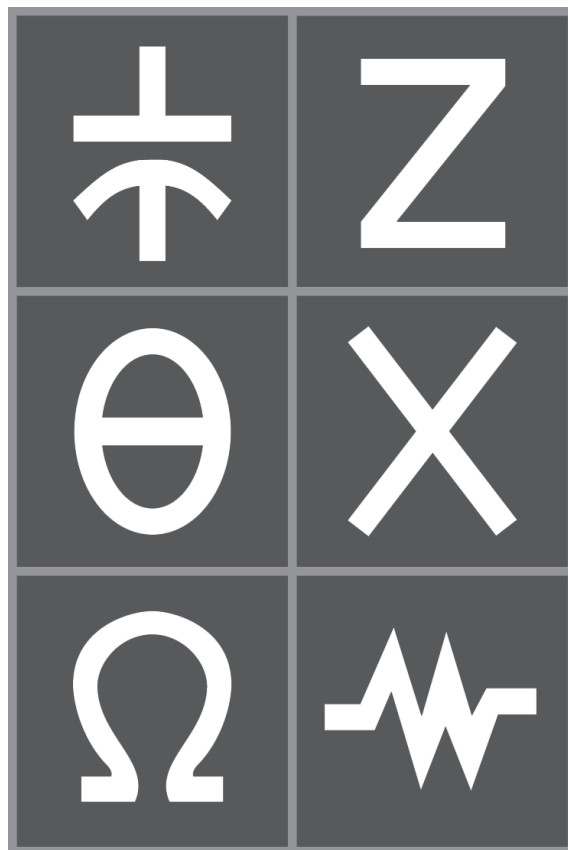


Table of Contents

1.0 Impedance Measurement Basics

1.1 Impedance	1-01
1.2 Measuring impedance	1-03
1.3 Parasitics: There are no pure R, C, and L components	1-03
1.4 Ideal, real, and measured values	1-04
1.5 Component dependency factors	1-05
1.5.1 Frequency	1-05
1.5.2 Test signal level	1-07
1.5.3 DC bias.....	1-07
1.5.4 Temperature.....	1-08
1.5.5 Other dependency factors.....	1-08
1.6 Equivalent circuit models of components.....	1-08
1.7 Measurement circuit modes.....	1-10
1.8 Three-element equivalent circuit and sophisticated component models	1-13
1.9 Reactance chart.....	1-15

2.0 Impedance Measurement Instruments

2.1 Measurement methods	2-01
2.2 Operating theory of practical instruments	2-04
LF impedance measurement	
2.3 Theory of auto balancing bridge method	2-04
2.3.1 Signal source section	2-06
2.3.2 Auto-balancing bridge section	2-07
2.3.3 Vector ratio detector section.....	2-08
2.4 Key measurement functions	2-09
2.4.1 Oscillator (OSC) level	2-09
2.4.2 DC bias	2-10
2.4.3 Ranging function	2-11
2.4.4 Level monitor function	2-12
2.4.5 Measurement time and averaging	2-12
2.4.6 Compensation function	2-13
2.4.7 Guarding	2-14
2.4.8 Grounded device measurement capability	2-15
RF impedance measurement	
2.5 Theory of RF I-V measurement method	2-16
2.6 Difference between RF I-V and network analysis measurement methods	2-17
2.7 Key measurement functions	2-19
2.7.1 OSC level	2-19
2.7.2 Test port	2-19
2.7.3 Calibration	2-20
2.7.4 Compensation	2-20
2.7.5 Measurement range	2-20
2.7.6 DC bias	2-20

3.0 Fixturing and Cabling

LF impedance measurement

3.1 Terminal configuration	3-01
3.1.1 Two-terminal configuration.....	3-02
3.1.2 Three-terminal configuration	3-02
3.1.3 Four-terminal configuration	3-04
3.1.4 Five-terminal configuration.....	3-05
3.1.5 Four-terminal pair configuration.....	3-06
3.2 Test fixtures	3-07
3.2.1 Keysight-supplied test fixtures.....	3-07
3.2.2 User-fabricated test fixtures.....	3-08
3.2.3 User test fixture example.....	3-09
3.3 Test cables	3-10
3.3.1 Keysight supplied test cables	3-10
3.3.2 User fabricated test cables	3-11
3.3.3 Test cable extension	3-11
3.4 Practical guarding techniques	3-15
3.4.1 Measurement error due to stray capacitances.....	3-15
3.4.2 Guarding techniques to remove stray capacitances.....	3-16

RF impedance measurement

3.5 Terminal configuration in RF region	3-16
3.6 RF test fixtures	3-17
3.6.1 Keysight-supplied test fixtures	3-18
3.7 Test port extension in RF region.....	3-19

4.0 Measurement Error and Compensation

Basic concepts and LF impedance measurement

4.1 Measurement error	4-01
4.2 Calibration	4-01
4.3 Compensation	4-03
4.3.1 Offset compensation	4-03
4.3.2 Open and short compensations	4-04
4.3.3 Open/short/load compensation	4-06
4.3.4 What should be used as the load?	4-07
4.3.5 Application limit for open, short, and load compensations	4-09
4.4 Measurement error caused by contact resistance	4-09
4.5 Measurement error induced by cable extension	4-11
4.5.1 Error induced by four-terminal pair (4TP) cable extension.....	4-11
4.5.2 Cable extension without termination.....	4-13
4.5.3 Cable extension with termination	4-13
4.5.4 Error induced by shielded 2T or shielded 4T cable extension	4-13
4.6 Practical compensation examples	4-14
4.6.1 Keysight test fixture (direct attachment type).....	4-14
4.6.2 Keysight test cables and Keysight test fixture.....	4-14
4.6.3 Keysight test cables and user-fabricated test fixture (or scanner).....	4-14
4.6.4 Non-Keysight test cable and user-fabricated test fixture.....	4-14

RF impedance measurement

4.7	Calibration and compensation in RF region	4-16
4.7.1	Calibration	4-16
4.7.2	Error source model	4-17
4.7.3	Compensation method	4-18
4.7.4	Precautions for open and short measurements in RF region	4-18
4.7.5	Consideration for short compensation	4-19
4.7.6	Calibrating load device	4-20
4.7.7	Electrical length compensation	4-21
4.7.8	Practical compensation technique	4-22
4.8	Measurement correlation and repeatability	4-22
4.8.1	Variance in residual parameter value	4-22
4.8.2	A difference in contact condition	4-23
4.8.3	A difference in open/short compensation conditions	4-24
4.8.4	Electromagnetic coupling with a conductor near the DUT	4-24
4.8.5	Variance in environmental temperature	4-25

5.0 Impedance Measurement Applications and Enhancements

5.1	Capacitor measurement	5-01
5.1.1	Parasitics of a capacitor	5-02
5.1.2	Measurement techniques for high/low capacitance	5-04
5.1.3	Causes of negative D problem	5-06
5.2	Inductor measurement	5-08
5.2.1	Parasitics of an inductor	5-08
5.2.2	Causes of measurement discrepancies for inductors	5-10
5.3	Transformer measurement	5-14
5.3.1	Primary inductance (L1) and secondary inductance (L2)	5-14
5.3.2	Inter-winding capacitance (C)	5-15
5.3.3	Mutual inductance (M)	5-15
5.3.4	Turns ratio (N)	5-16
5.4	Diode measurement	5-18
5.5	MOS FET measurement	5-19
5.6	Silicon wafer C-V measurement	5-20
5.7	High-frequency impedance measurement using the probe	5-23
5.8	Resonator measurement	5-24
5.9	Cable measurements	5-27
5.9.1	Balanced cable measurement	5-28
5.10	Balanced device measurement	5-29
5.11	Battery measurement	5-31
5.12	Test signal voltage enhancement	5-32
5.13	DC bias voltage enhancement	5-34
5.13.1	External DC voltage bias protection in 4TP configuration	5-35
5.14	DC bias current enhancement	5-36
5.14.1	External current bias circuit in 4TP configuration	5-37
5.15	Equivalent circuit analysis function and its application	5-38

Appendix A: The Concept of a Test Fixture's Additional Error	A-01
A.1 System configuration for impedance measurement	A-01
A.2 Measurement system accuracy.....	A-01
A.2.1 Proportional error	A-02
A.2.2 Short offset error	A-02
A.2.3 Open offset error.....	A-03
A.3 New market trends and the additional error for test fixtures	A-03
A.3.1 New devices.....	A-03
A.3.2 DUT connection configuration	A-04
A.3.3 Test fixture's adaptability for a particular measurement.....	A-05
Appendix B: Open and Short Compensation	B-01
Appendix C: Open, Short, and Load Compensation	C-01
Appendix D: Electrical Length Compensation	D-01
Appendix E: Q Measurement Accuracy Calculation	E-01

1.0 Impedance Measurement Basics

1.1 Impedance

Impedance is an important parameter used to characterize electronic circuits, components, and the materials used to make components. Impedance (Z) is generally defined as the total opposition a device or circuit offers to the flow of an alternating current (AC) at a given frequency, and is represented as a complex quantity which is graphically shown on a vector plane. An impedance vector consists of a real part (resistance, R) and an imaginary part (reactance, X) as shown in Figure 1-1. Impedance can be expressed using the rectangular-coordinate form $R + jX$ or in the polar form as a magnitude and phase angle: $|Z| \angle \theta$. Figure 1-1 also shows the mathematical relationship between R , X , $|Z|$, and θ . In some cases, using the reciprocal of impedance is mathematically expedient. In which case $1/Z = 1/(R + jX) = Y = G + jB$, where Y represents admittance, G conductance, and B susceptance. The unit of impedance is the ohm (Ω), and admittance is the siemen (S). Impedance is a commonly used parameter and is especially useful for representing a series connection of resistance and reactance, because it can be expressed simply as a sum, R and X . For a parallel connection, it is better to use admittance (see Figure 1-2.)

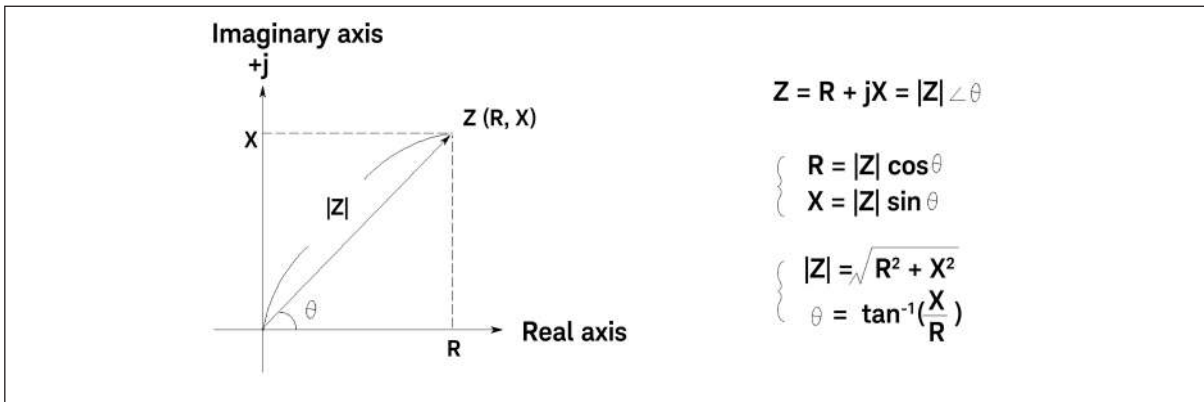


Figure 1-1. Impedance (Z) consists of a real part (R) and an imaginary part (X)

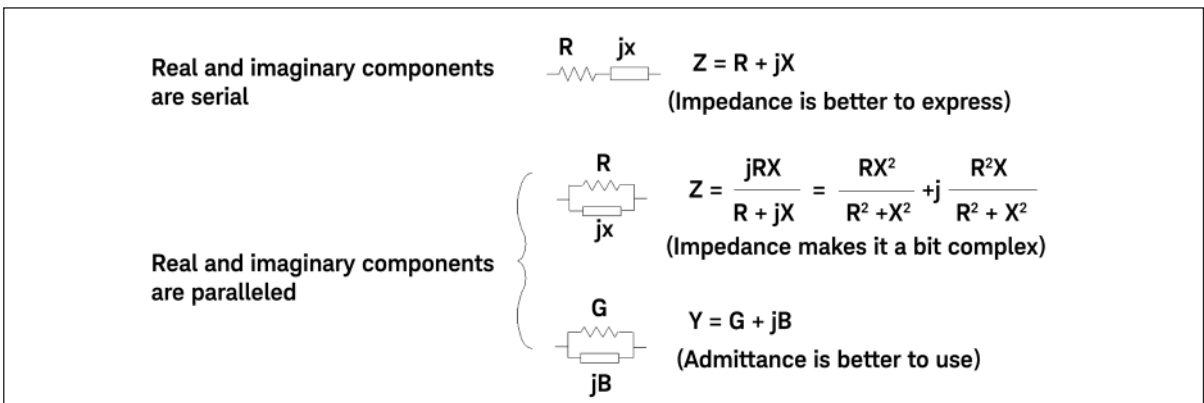


Figure 1-2. Expression of series and parallel combination of real and imaginary components

Reactance takes two forms: inductive (X_L) and capacitive (X_C). By definition, $X_L = 2\pi fL$ and $X_C = 1/(2\pi fC)$, where f is the frequency of interest, L is inductance, and C is capacitance. $2\pi f$ can be substituted for by the angular frequency (ω : omega) to represent $X_L = \omega L$ and $X_C = 1/(\omega C)$. Refer to Figure 1-3.



Figure 1-3. Reactance in two forms: inductive (X_L) and capacitive (X_C)

A similar reciprocal relationship applies to susceptance and admittance. Figure 1-4 shows a typical representation for a resistance and a reactance connected in series or in parallel.

The quality factor (Q) serves as a measure of a reactance's purity (how close it is to being a pure reactance, no resistance), and is defined as the ratio of the energy stored in a component to the energy dissipated by the component. Q is a dimensionless unit and is expressed as $Q = X/R = B/G$. From Figure 1-4, you can see that Q is the tangent of the angle θ . Q is commonly applied to inductors; for capacitors the term more often used to express purity is dissipation factor (D). This quantity is simply the reciprocal of Q , it is the tangent of the complementary angle of θ , the angle δ shown in Figure 1-4 (d).

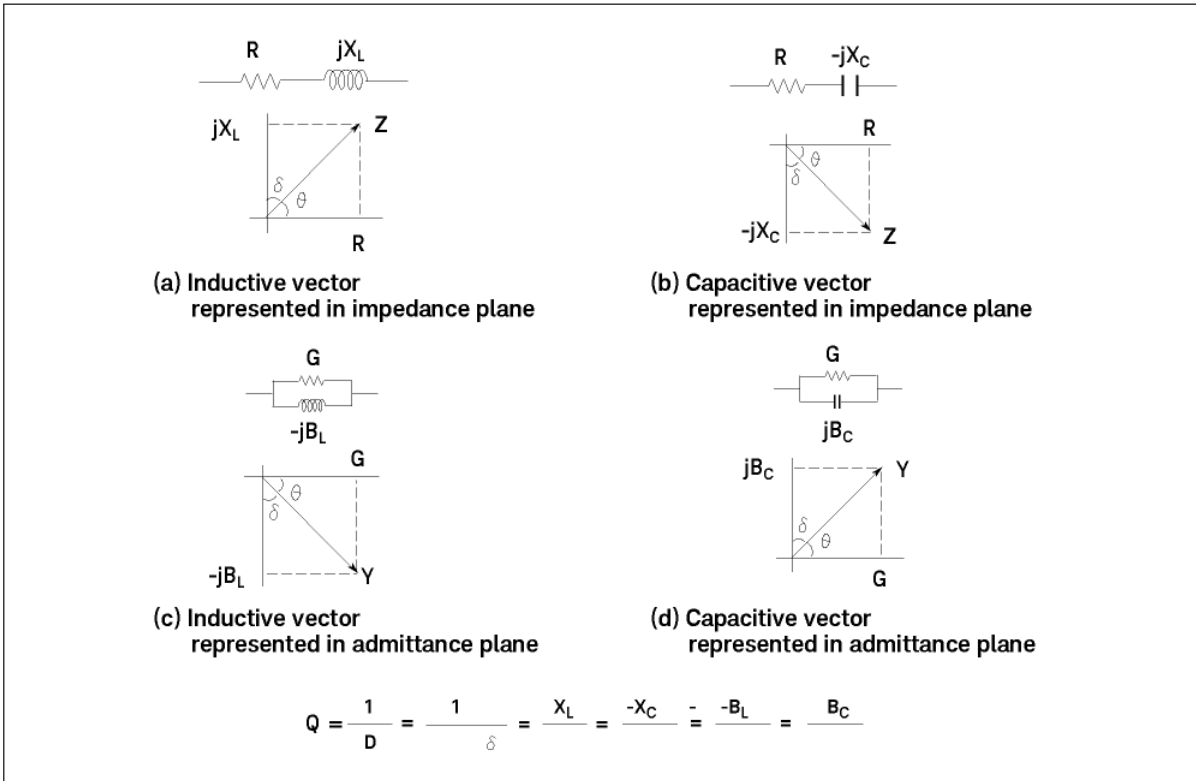


Figure 1-4. Relationships between impedance and admittance parameters

1.2 Measuring impedance

To find the impedance, we need to measure at least two values because impedance is a complex quantity. Many modern impedance measuring instruments measure the real and the imaginary parts of an impedance vector and then convert them into the desired parameters such as $|Z|$, θ , $|Y|$, R , X , G , B , C , and L . It is only necessary to connect the unknown component, circuit, or material to the instrument. Measurement ranges and accuracy for a variety of impedance parameters are determined from those specified for impedance measurement.

Automated measurement instruments allow you to make a measurement by merely connecting the unknown component, circuit, or material to the instrument. However, sometimes the instrument will display an unexpected result (too high or too low.) One possible cause of this problem is incorrect measurement technique, or the natural behavior of the unknown device. In this section, we will focus on the traditional passive components and discuss their natural behavior in the real world as compared to their ideal behavior.

1.3 Parasitics: There are no pure R, C, and L components

The principal attributes of L, C, and R components are generally represented by the nominal values of capacitance, inductance, or resistance at specified or standardized conditions. However, all circuit components are neither purely resistive, nor purely reactive. They involve both of these impedance elements. This means that all real-world devices have parasitics—unwanted inductance in resistors, unwanted resistance in capacitors, unwanted capacitance in inductors, etc. Different materials and manufacturing technologies produce varying amounts of parasitics. In fact, many parasitics reside in components, affecting both a component's usefulness and the accuracy with which you can determine its resistance, capacitance, or inductance. With the combination of the component's primary element and parasitics, a component will be like a complex circuit, if it is represented by an equivalent circuit model as shown in Figure 1-5.

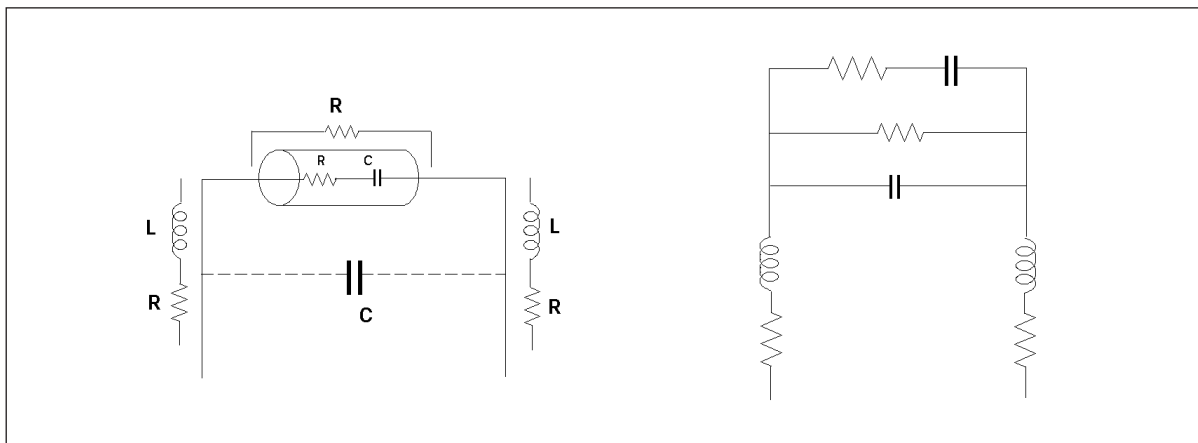


Figure 1-5. Component (capacitor) with parasitics represented by an electrical equivalent circuit

Since the parasitics affect the characteristics of components, the C, L, R, D, Q, and other inherent impedance parameter values vary depending on the operating conditions of the components. Typical dependence on the operating conditions is described in Section 1.5.

1.4 Ideal, real, and measured values

When you determine an impedance parameter value for a circuit component (resistor, inductor, or capacitor), it is important to thoroughly understand what the value indicates in reality. The parasitics of the component and the measurement error sources, such as the test fixture's residual impedance, affect the value of impedance. Conceptually, there are three sorts of values: ideal, real, and measured. These values are fundamental to comprehending the impedance value obtained through measurement. In this section, we learn the concepts of ideal, real, and measured values, as well as their significance to practical component measurements.

- An ideal value is the value of a circuit component (resistor, inductor, or capacitor) that excludes the effects of its parasitics. The model of an ideal component assumes a purely resistive or reactive element that has no frequency dependence. In many cases, the ideal value can be defined by a mathematical relationship involving the component's physical composition (Figure 1-6 (a).) In the real world, ideal values are only of academic interest.
- The real value takes into consideration the effects of a component's parasitics (Figure 1-6 (b).) The real value represents effective impedance, which a real-world component exhibits. The real value is the algebraic sum of the circuit component's resistive and reactive vectors, which come from the principal element (deemed as a pure element) and the parasitics. Since the parasitics yield a different impedance vector for a different frequency, the real value is frequency dependent.
- The measured value is the value obtained with, and displayed by, the measurement instrument; it reflects the instrument's inherent residuals and inaccuracies (Figure 1-6 (c).) Measured values always contain errors when compared to real values. They also vary intrinsically from one measurement to another; their differences depend on a multitude of considerations in regard to measurement uncertainties. We can judge the quality of measurements by comparing how closely a measured value agrees with the real value under a defined set of measurement conditions. The measured value is what we want to know, and the goal of measurement is to have the measured value be as close as possible to the real value.

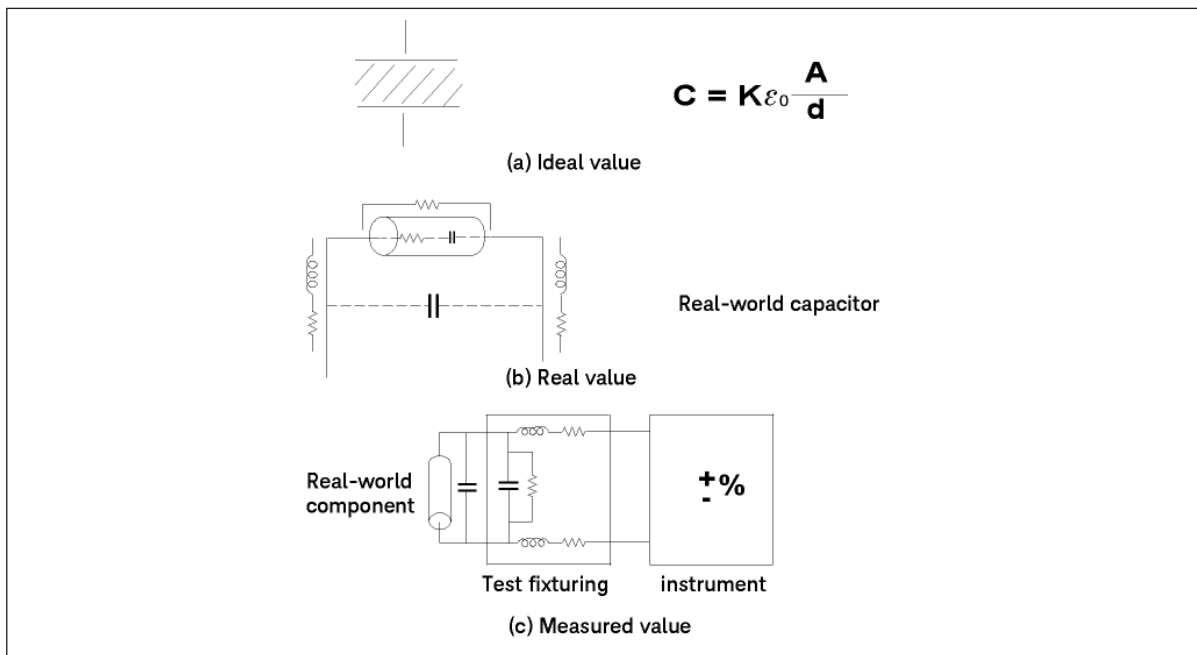


Figure 1-6. Ideal, real, and measured values

1.5 Component dependency factors

The measured impedance value of a component depends on several measurement conditions, such as test frequency, and test signal level. Effects of these component dependency factors are different for different types of materials used in the component, and by the manufacturing process used. The following are typical dependency factors that affect the impedance values of measured components.

1.5.1 Frequency

Frequency dependency is common to all real-world components because of the existence of parasitics. Not all parasitics affect the measurement, but some prominent parasitics determine the component's frequency characteristics. The prominent parasitics will be different when the impedance value of the primary element is not the same. Figures 1-7 through 1-9 show the typical frequency response for real-world capacitors, inductors, and resistors.

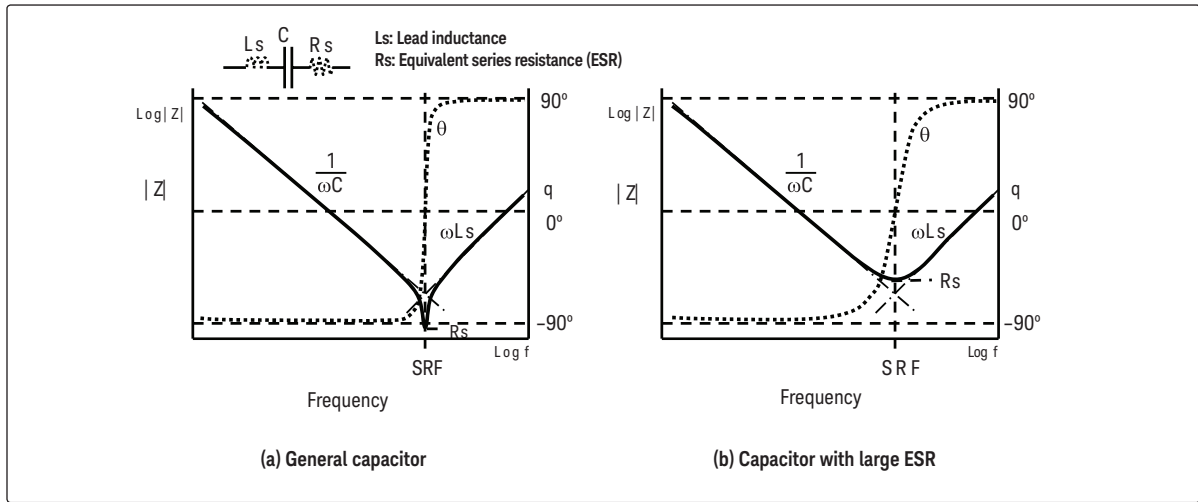


Figure 1-7. Capacitor frequency response

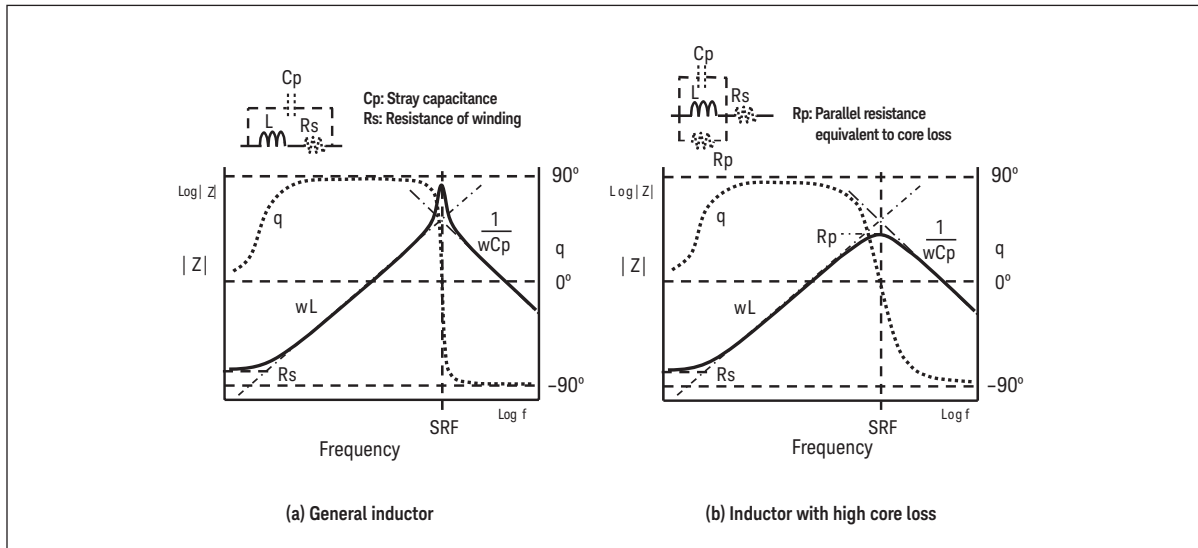


Figure 1-8. Inductor frequency response

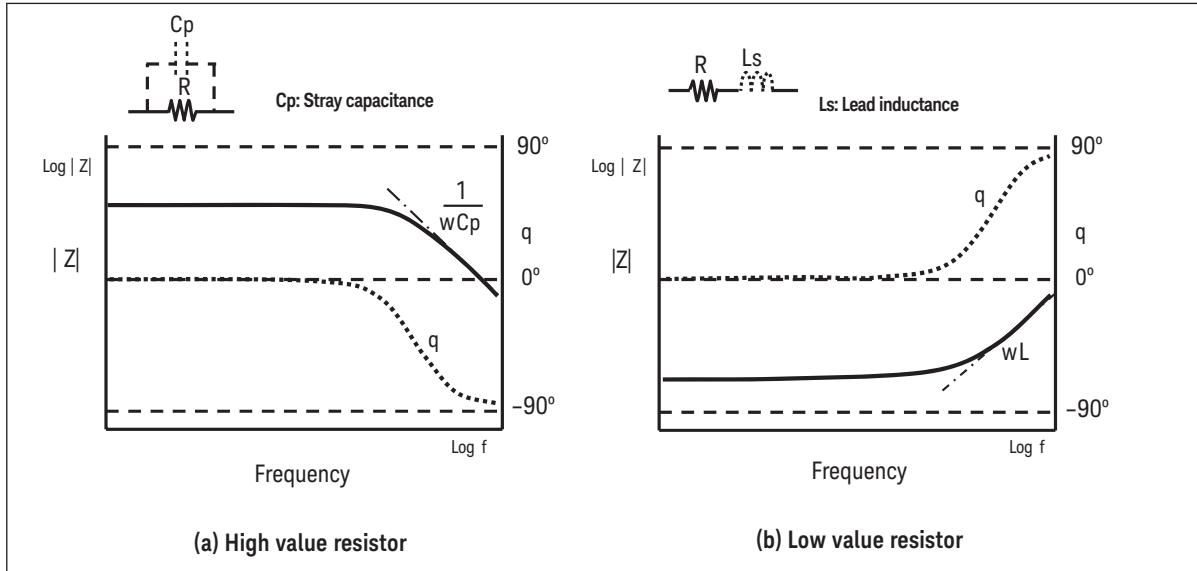


Figure 1-9. Resistor frequency response

As for capacitors, parasitic inductance is the prime cause of the frequency response as shown in Figure 1-7. At low frequencies, the phase angle (θ) of impedance is around -90° , so the reactance is capacitive. The capacitor frequency response has a minimum impedance point at a self-resonant frequency (SRF), which is determined from the capacitance and parasitic inductance (L_s) of a series equivalent circuit model for the capacitor. At the self-resonant frequency, the capacitive and inductive reactance values are equal ($1/(\omega C) = \omega L_s$.) As a result, the phase angle is 0° and the device is resistive. After the resonant frequency, the phase angle changes to a positive value around $+90^\circ$ and, thus, the inductive reactance due to the parasitic inductance is dominant.

Capacitors behave as inductive devices at frequencies above the SRF and, as a result, cannot be used as a capacitor. Likewise, regarding inductors, parasitic capacitance causes a typical frequency response as shown in Figure 1-8. Due to the parasitic capacitance (C_p), the inductor has a maximum impedance point at the SRF (where $\omega L = 1/(\omega C_p)$.) In the low frequency region below the SRF, the reactance is inductive. After the resonant frequency, the capacitive reactance due to the parasitic capacitance is dominant. The SRF determines the maximum usable frequency of capacitors and inductors.

1.5.2 Test signal level

The test signal (AC) applied may affect the measurement result for some components. For example, ceramic capacitors are test-signal-voltage dependent as shown in Figure 1-10 (a). This dependency varies depending on the dielectric constant (K) of the material used to make the ceramic capacitor.

Cored-inductors are test-signal-current dependent due to the electromagnetic hysteresis of the core material. Typical AC current characteristics are shown in Figure 1-10 (b).

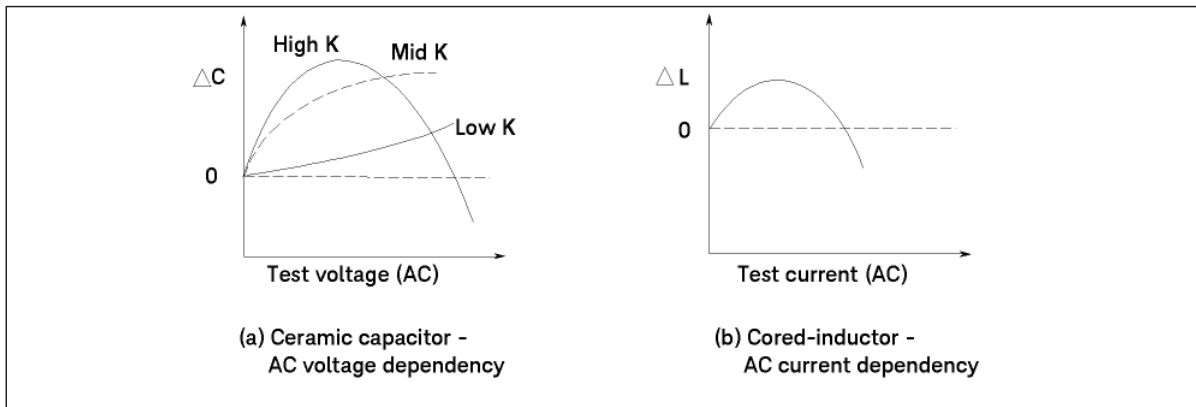


Figure 1-10. Test signal level (AC) dependencies of ceramic capacitors and cored-inductors

1.5.3 DC bias

DC bias dependency is very common in semiconductor components such as diodes and transistors. Some passive components are also DC bias dependent. The capacitance of a high-K type dielectric ceramic capacitor will vary depending on the DC bias voltage applied, as shown in Figure 1-11 (a).

In the case of cored-inductors, the inductance varies according to the DC bias current flowing through the coil. This is due to the magnetic flux saturation characteristics of the core material. Refer to Figure 1-11 (b).

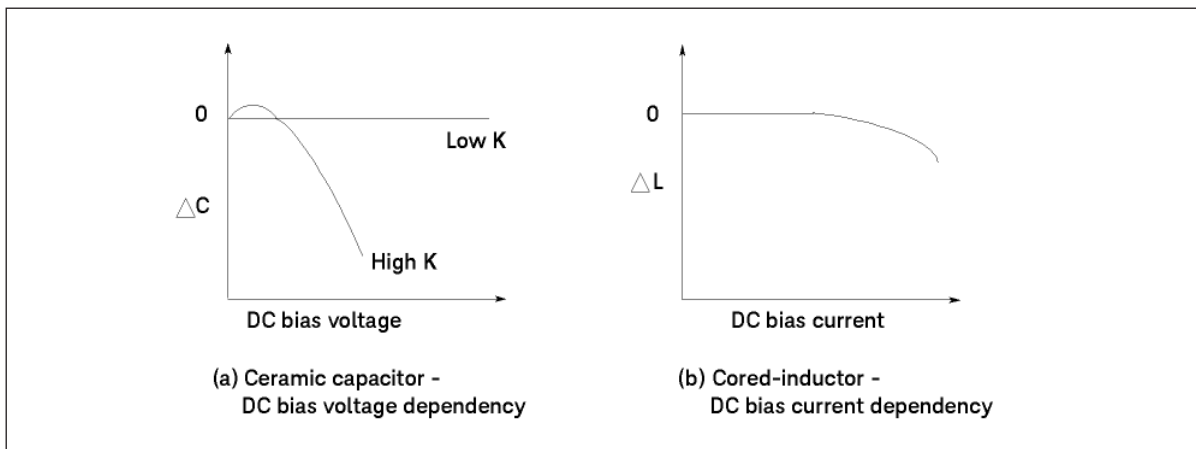


Figure 1-11. DC bias dependencies of ceramic capacitors and cored-inductors

1.5.4 Temperature

Most types of components are temperature dependent. The temperature coefficient is an important specification for resistors, inductors, and capacitors. Figure 1-12 shows some typical temperature dependencies that affect ceramic capacitors with different dielectrics.

1.5.5 Other dependency factors

Other physical and electrical environments, e.g., humidity, magnetic fields, light, atmosphere, vibration, and time, may change the impedance value. For example, the capacitance of a high-K type dielectric ceramic capacitor decreases with age as shown in Figure 1-13.

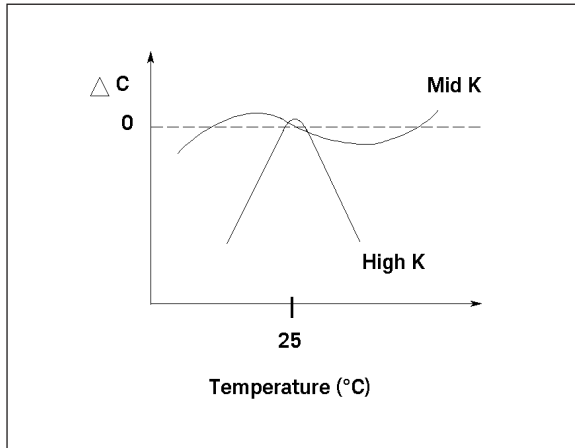


Figure 1-12. Temperature dependency of ceramic capacitors

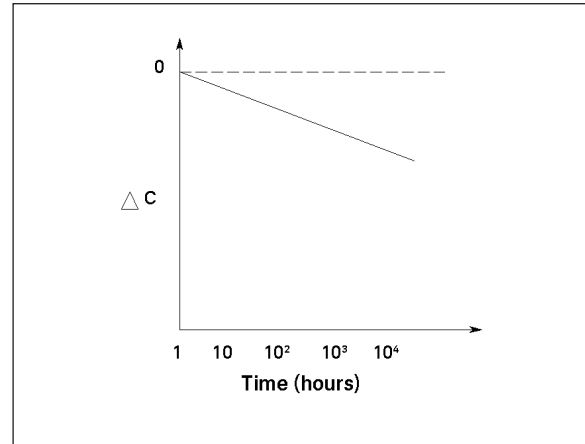


Figure 1-13. Aging dependency of ceramic capacitors

1.6 Equivalent circuit models of components

Even if an equivalent circuit of a device involving parasitics is complex, it can be lumped as the simplest series or parallel circuit model, which represents the real and imaginary (resistive and reactive) parts of total equivalent circuit impedance. For instance, Figure 1-14 (a) shows a complex equivalent circuit of a capacitor. In fact, capacitors have small amounts of parasitic elements that behave as series resistance (R_s), series inductance (L_s), and parallel resistance (R_p or $1/G$.) In a sufficiently low frequency region, compared with the SRF, parasitic inductance (L_s) can be ignored. When the capacitor exhibits a high reactance ($1/(\omega C)$), parallel resistance (R_p) is the prime determinative, relative to series resistance (R_s), for the real part of the capacitor's impedance. Accordingly, a parallel equivalent circuit consisting of C and R_p (or G) is a rational approximation to the complex circuit model. When the reactance of a capacitor is low, R_s is a more significant determinative than R_p . Thus, a series equivalent circuit comes to the approximate model. As for a complex equivalent circuit of an inductor such as that shown in Figure 1-14 (b), stray capacitance (C_p) can be ignored in the low frequency region. When the inductor has a low reactance, (ωL), a series equivalent circuit model consisting of L and R_s can be deemed as a good approximation. The resistance, R_s , of a series equivalent circuit is usually called equivalent series resistance (ESR).

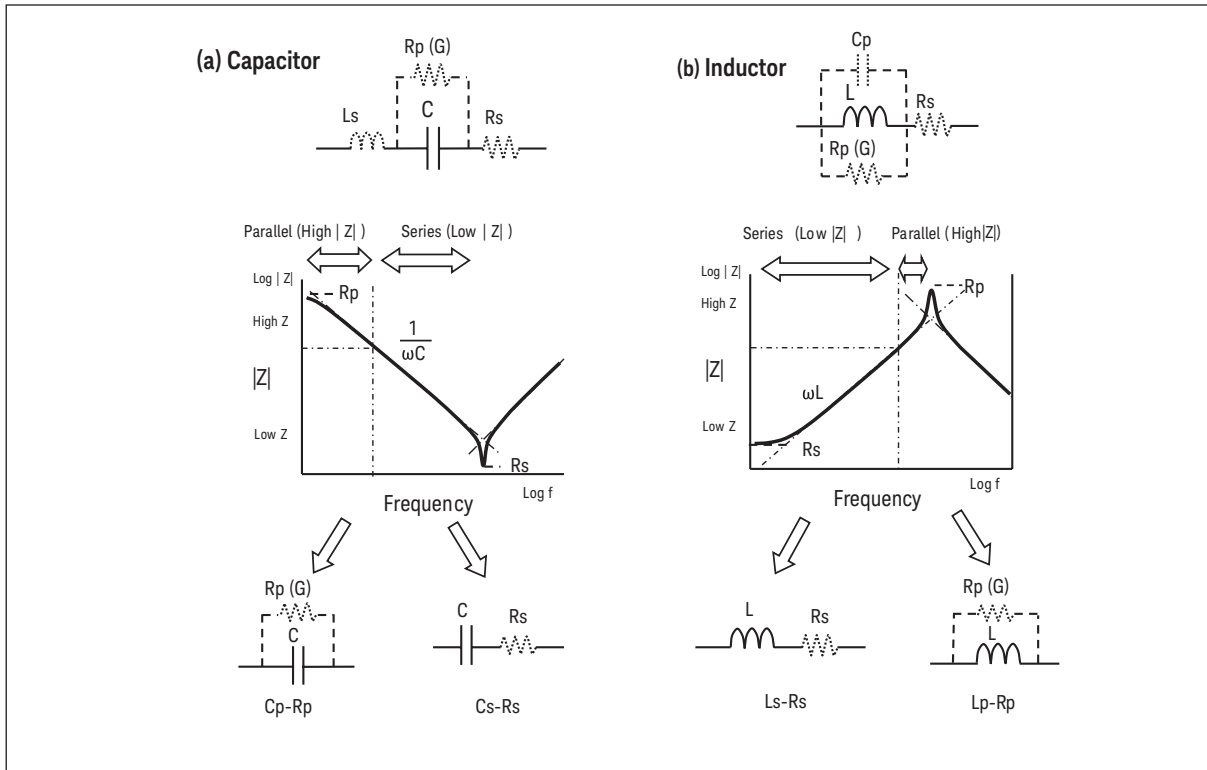


Figure 1-14. Equivalent circuit models of (a) a capacitor and (b) an inductor

Note: Generally, the following criteria can be used to roughly discriminate between low, middle, and high impedances (Figure 1-15.) The medium Z range may be covered with an extension of either the low Z or high Z range. These criteria differ somewhat, depending on the frequency and component type.

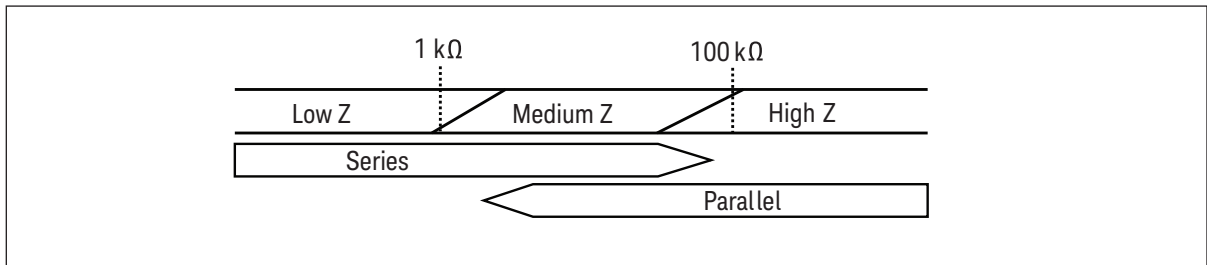


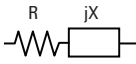
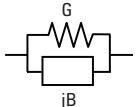
Figure 1-15. High and low impedance criteria

In the frequency region where the primary capacitance or inductance of a component exhibits almost a flat frequency response, either a series or parallel equivalent circuit can be applied as a suitable model to express the real impedance characteristic. Practically, the simplest series and parallel models are effective in most cases when representing characteristics of general capacitor, inductor, and resistor components.

1.7 Measurement circuit modes

As we learned in Section 1.2, measurement instruments basically measure the real and imaginary parts of impedance and calculate from them a variety of impedance parameters such as R, X, G, B, C, and L. You can choose from series and parallel measurement circuit modes to obtain the measured parameter values for the desired equivalent circuit model (series or parallel) of a component as shown in Table 1-1.



Table 1-1. Measurement circuit modes

Equivalent circuit models of component	Measurement circuit modes and impedance parameters
Series 	Series mode: Cs, Ls, Rs, Xs
Parallel 	Parallel mode: Cp, Lp, Rp, Gp, Bp

Though impedance parameters of a component can be expressed by whichever circuit mode (series or parallel) is used, either mode is suited to characterize the component at your desired frequencies. Selecting an appropriate measurement circuit mode is often vital for accurate analysis of the relationships between parasitics and the component’s physical composition or material properties. One of the reasons is that the calculated values of C, L, R, and other parameters are different depending on the measurement circuit mode as described later. Of course, defining the series or parallel equivalent circuit model of a component is fundamental to determining which measurement circuit mode (series or parallel) should be used when measuring C, L, R, and other impedance parameters of components. The criteria shown in Figure 1-15 can also be used as a guideline for selecting the measurement circuit mode suitable for a component.

Table 1-2 shows the definitions of impedance measurement parameters for the series and parallel modes. For the parallel mode, admittance parameters are used to facilitate parameter calculations.

Table 1-2. Definitions of impedance parameters for series and parallel modes

Series mode	Parallel mode
 $ Z = \sqrt{R_s^2 + X_s^2}$ $\theta = \tan^{-1} (X_s/R_s)$	 $ Y = \sqrt{G_p^2 + B_p^2}$ $\theta = \tan^{-1} (B_p/G_p)$
Rs: Series resistance Xs: Series reactance ($X_L = \omega L_s$, $X_C = -1/(\omega C_s)$) Ls: Series inductance ($= X_L/\omega$) Cs: Series capacitance ($= -1/(\omega X_C)$) D: Dissipation factor ($= R_s/X_s = R_s/(\omega L_s)$ or $\omega C_s R_s$) Q: Quality factor ($= X_s/R_s = \omega L_s/R_s$ or $1/(\omega C_s R_s)$)	Gp: Parallel conductance ($= 1/R_p$) Bp: Parallel susceptance ($B_C = \omega C_p$, $B_L = -1/(\omega L_p)$) Lp: Parallel inductance ($= -1/(\omega B_L)$) Cp: Parallel capacitance ($= B_C/\omega$) D: Dissipation factor ($= G_p/B_p = G_p/(\omega C_p)$ $= 1/(\omega C_p R_p)$ or $\omega L_p G_p = \omega L_p/R_p$) Q: Quality factor ($= B_p/G_p = \omega C_p/G_p$ $= \omega C_p R_p$ or $1/(\omega L_p G_p) = R_p/(\omega L_p)$)

Though series and parallel mode impedance values are identical, the reactance (X_s), is not equal to reciprocal of parallel susceptance (B_p), except when $R_s = 0$ and $G_p = 0$. Also, the series resistance (R_s), is not equal to parallel resistance (R_p) (or reciprocal of G_p) except when $X_s = 0$ and $B_p = 0$. From the definition of $Y = 1/Z$, the series and parallel mode parameters, R_s , G_p ($1/R_p$), X_s , and B_p are related with each other by the following equations:

$$Z = R_s + jX_s = 1/Y = 1/(G_p + jB_p) = G_p/(G_p^2 + B_p^2) - jB_p/(G_p^2 + B_p^2)$$

$$Y = G_p + jB_p = 1/Z = 1/(R_s + jX_s) = R_s/(R_s^2 + X_s^2) - jX_s/(R_s^2 + X_s^2)$$

$$R_s = G_p/(G_p^2 + B_p^2) \quad R_s = R_p D^2/(1 + D^2)$$



$$G_p = R_s/(R_s^2 + X_s^2) \quad R_p = R_s(1 + 1/D^2)$$

$$X_s = -B_p/(G_p^2 + B_p^2) \quad X_s = X_p/(1 + D^2)$$

$$B_p = -X_s/(R_s^2 + X_s^2) \quad X_p = X_s(1 + D^2)$$

Table 1-3 shows the relationships between the series and parallel mode values for capacitance, inductance, and resistance, which are derived from the above equations.

Table 1-3. Relationships between series and parallel mode CLR values

	Series	Parallel	Dissipation factor
	$R_s \pm jX_s$ 	G_p 	(Same value for series and parallel)
Capacitance	$C_s = C_p(1 + D^2)$	$C_p = C_s/(1 + D^2)$	$D = R_s/X_s = \omega C_s R_s$ $D = G_p/B_p = G_p/(\omega C_p) = 1/(\omega C_p R_p)$
Inductance	$L_s = L_p/(1 + D^2)$	$L_p = L_s(1 + D^2)$	$D = R_s/X_s = R_s/(\omega L_s)$ $D = G_p/B_p = \omega L_p G_p = \omega L_p/R_p$
Resistance	$R_s = R_p D^2/(1 + D^2)$	$R_p = R_s(1 + 1/D^2)$	-----

C_s , L_s , and R_s values of a series equivalent circuit are different from the C_p , L_p , and R_p values of a parallel equivalent circuit. For this reason, the selection of the measurement circuit mode can become a cause of measurement discrepancies. Fortunately, the series and parallel mode measurement values are interrelated by using simple equations that are a function of the dissipation factor (D .) In a broad sense, the series mode values can be converted into parallel mode values and vice versa.

Figure 1-16 shows the C_p/C_s and C_s/C_p ratios calculated for dissipation factors from 0.01 to 1.0. As for inductance, the L_p/L_s ratio is same as C_s/C_p and the L_s/L_p ratio equals C_p/C_s .

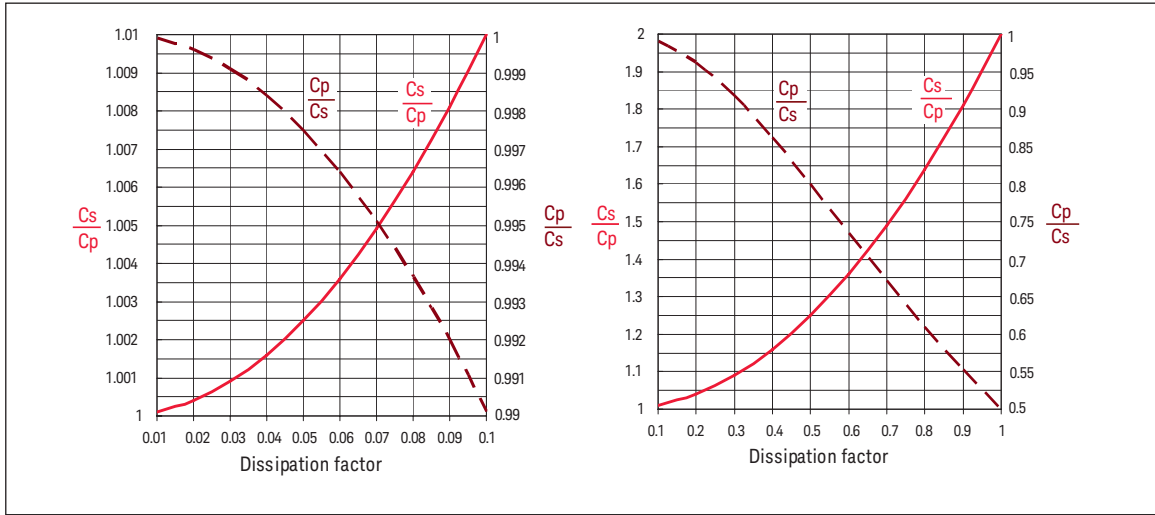


Figure 1-16. Relationships of series and parallel capacitance values

For high D (low Q) devices, either the series or parallel model is a better approximation of the real impedance equivalent circuit than the other one. Low D (high Q) devices do not yield a significant difference in measured C or L values due to the measurement circuit mode. Since the relationships between the series and parallel mode measurement values are a function of D^2 , when D is below 0.03, the difference between C_s and C_p values (also between L_s and L_p values) is less than 0.1 percent. D and Q values do not depend on the measurement circuit modes.

Figure 1-17 shows the relationship between series and parallel mode resistances. For high D (low Q) components, the measured R_s and R_p values are almost equal because the impedance is nearly pure resistance. Since the difference between R_s and R_p values increases in proportion to $1/D^2$, defining the measurement circuit mode is vital for measurement of capacitive or inductive components with low D (high Q.)

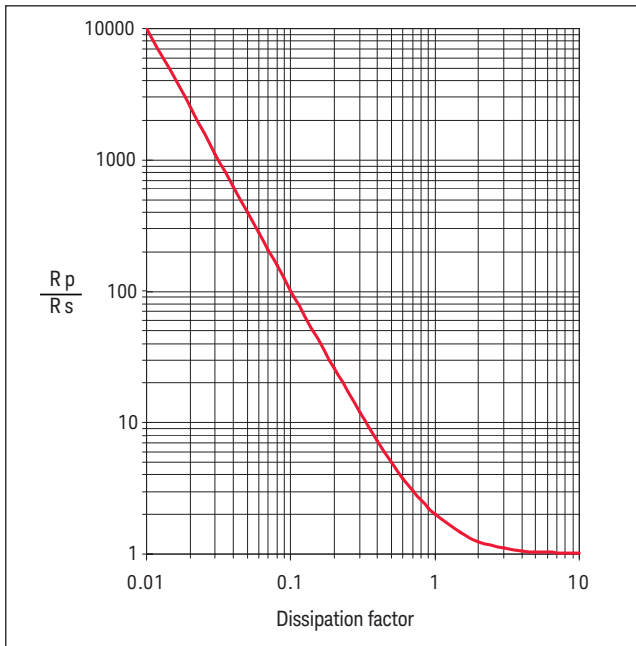


Figure 1-17. Relationships of series and parallel resistance values

1.8 Three-element equivalent circuit and sophisticated component models

The series and parallel equivalent circuit models cannot serve to accurately depict impedance characteristics of components over a broad frequency range because various parasitics in the components exercise different influence on impedance depending on the frequency. For example, capacitors exhibit typical frequency response due to parasitic inductance, as shown in Figure 1-18. Capacitance rapidly increases as frequency approaches the resonance point. The capacitance goes down to zero at the SRF because impedance is purely resistive. After the resonant frequency, the measured capacitance exhibits a negative value, which is calculated from inductive reactance. In the aspect of the series Cs-Rs equivalent circuit model, the frequency response is attributed to a change in effective capacitance. The effect of parasitic inductance is unrecognizable unless separated out from the compound reactance. In this case, introducing series inductance (Ls) into the equivalent circuit model enables the real impedance characteristic to be properly expressed with three-element (Ls-Cs-Rs) equivalent circuit parameters. When the measurement frequency is lower than approximately 1/30 resonant frequency, the series Cs-Rs measurement circuit mode (with no series inductance) can be applied because the parasitic inductance scarcely affects measurements.

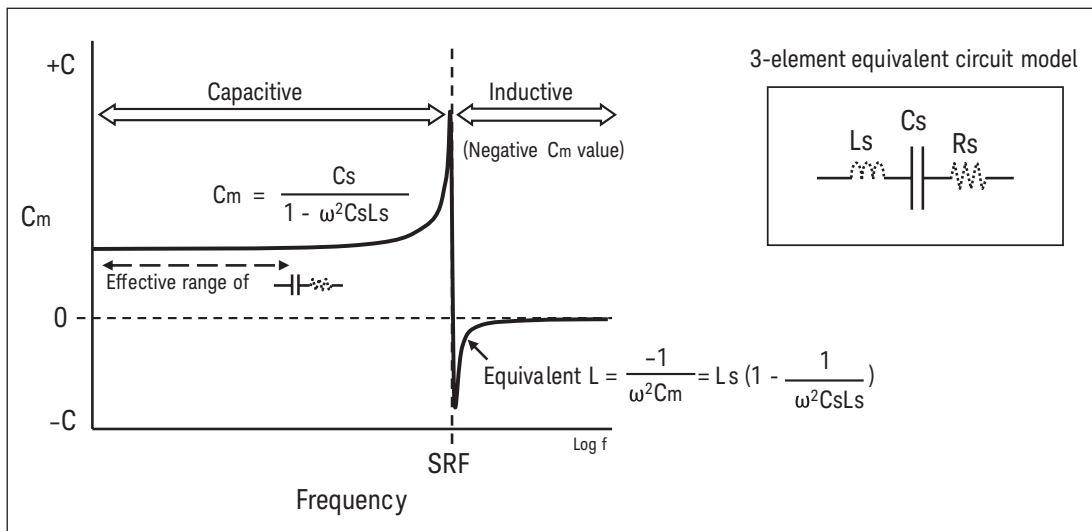


Figure 1-18. Influence of parasitic inductance on capacitor

When both series and parallel resistances have a considerable amount of influence on the impedance of a reactive device, neither the series nor parallel equivalent circuit models may serve to accurately represent the real C, L, or R value of the device. In the case of the capacitive device shown in Figure 1-19, both series and parallel mode capacitance (Cs and Cp) measurement values at 1 MHz are different from the real capacitance of the device. The correct capacitance value can be determined by deriving three-element (C-Rp-Rs) equivalent circuit parameters from the measured impedance characteristic. In practice, C-V characteristics measurement for an ultra-thin CMOS gate capacitance often requires a three-element (C-Rs-Rp) equivalent circuit model to be used for deriving real capacitance without being affected by Rs and Rp.

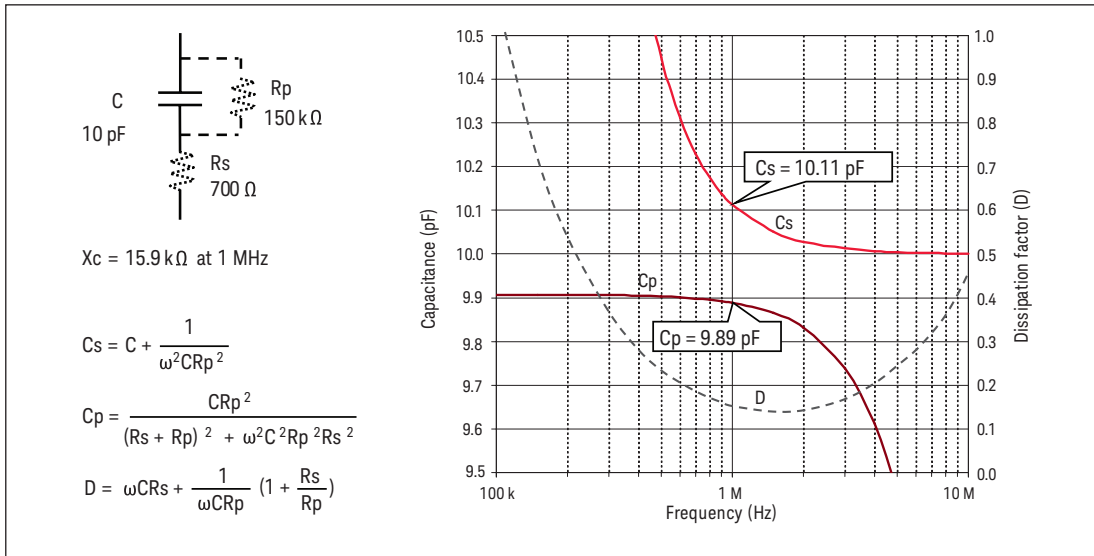


Figure 1-19. Example of capacitive device affected by both Rs and Rp

By measuring impedance at a frequency you can acquire a set of the equivalent resistance and reactance values, but it is not enough to determine more than two equivalent circuit elements. In order to derive the values of more than two equivalent circuit elements for a sophisticated model, a component needs to be measured at least at two frequencies. The Keysight Technologies, Inc. impedance analyzers have the equivalent circuit analysis function that automatically calculates the equivalent circuit elements for three- or four-element models from a result of a swept frequency measurement. The details of selectable three-/four-element equivalent circuit models and the equivalent circuit analysis function are described in Section 5.15.

1.9 Reactance chart

The reactance chart shows the impedance and admittance values of pure capacitance or inductance at arbitrary frequencies. Impedance values at desired frequencies can be indicated on the chart without need of calculating $1/(\omega C)$ or ωL values when discussing an equivalent circuit model for a component and also when estimating the influence of parasitics. To cite an example, impedance (reactance) of a 1 nF capacitor, which is shown with an oblique bold line in Figure 1-20, exhibits 160 k Ω at 1 kHz and 16 Ω at 10 MHz. Though a parasitic series resistance of 0.1 Ω can be ignored at 1 kHz, it yields a dissipation factor of 0.0063 (ratio of 0.1 Ω to 16 Ω) at 10 MHz. Likewise, though a parasitic inductance of 10 nH can be ignored at 1 kHz, its reactive impedance goes up to 0.63 Ω at 10 MHz and increases measured capacitance by +4 percent (this increment is calculated as $1/(1 - X_L/X_C) = 1/(1 - 0.63/16)$.) At the intersection of 1 nF line (bold line) and the 10 nH line at 50.3 MHz, the parasitic inductance has the same magnitude (but opposing vector) of reactive impedance as that of primary capacitance and causes a resonance (SRF). As for an inductor, the influence of parasitics can be estimated in the same way by reading impedance (reactance) of the inductor and that of a parasitic capacitance or a resistance from the chart.

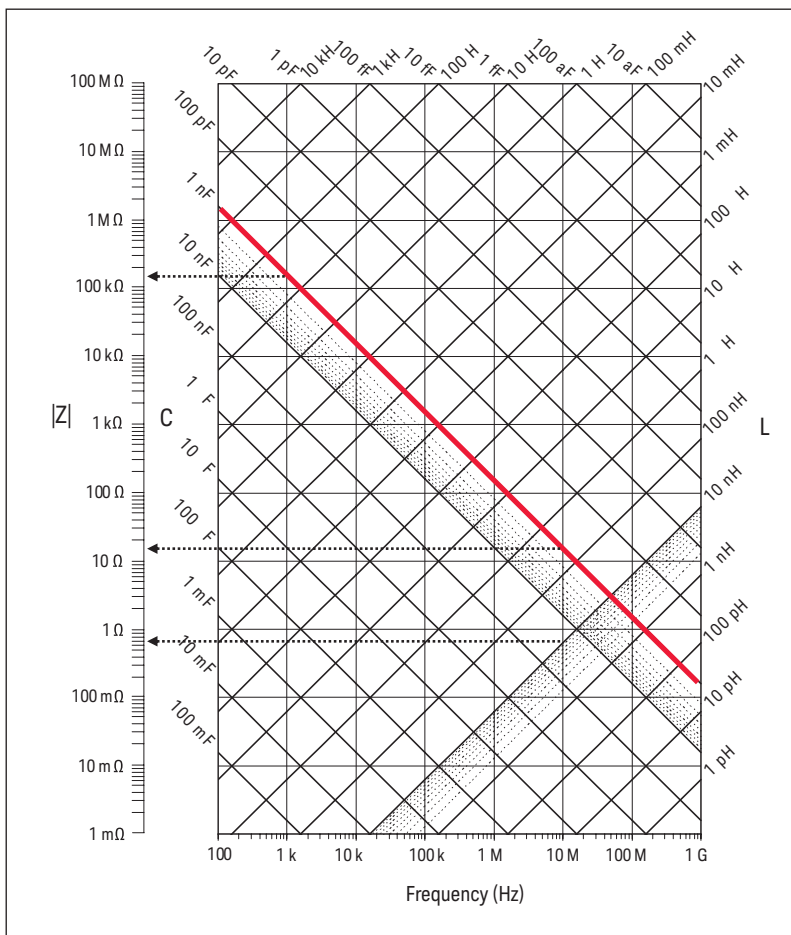


Figure 1-20. Reactance chart

Most of the modern impedance measuring instruments basically measure vector impedance ($R + jX$) or vector admittance ($G + jB$) and convert them, by computation, into various parameters, C_s , C_p , L_s , L_p , D , Q , $|Z|$, $|Y|$, θ , etc. Since measurement range and accuracy are specified for the impedance and admittance, both the range and accuracy for the capacitance and inductance vary depending on frequency. The reactance chart is also useful when estimating measurement accuracy for capacitance and inductance at your desired frequencies. You can plot the nominal value of a DUT on the chart and find the measurement accuracy denoted for the zone where the DUT value is enclosed. Figure 1-21 shows an example of measurement accuracy given in the form of a reactance chart. The intersection of arrows in the chart indicates that the inductance accuracy for $1 \mu\text{H}$ at 1 MHz is ± 0.3 percent. D accuracy comes to ± 0.003 ($= 0.3/100$.) Since the reactance is 6.28Ω , R_s accuracy is calculated as $\pm(6.28 \times 0.003) = \pm 0.019 \Omega$. Note that a strict accuracy specification applied to various measurement conditions is given by the accuracy equation.

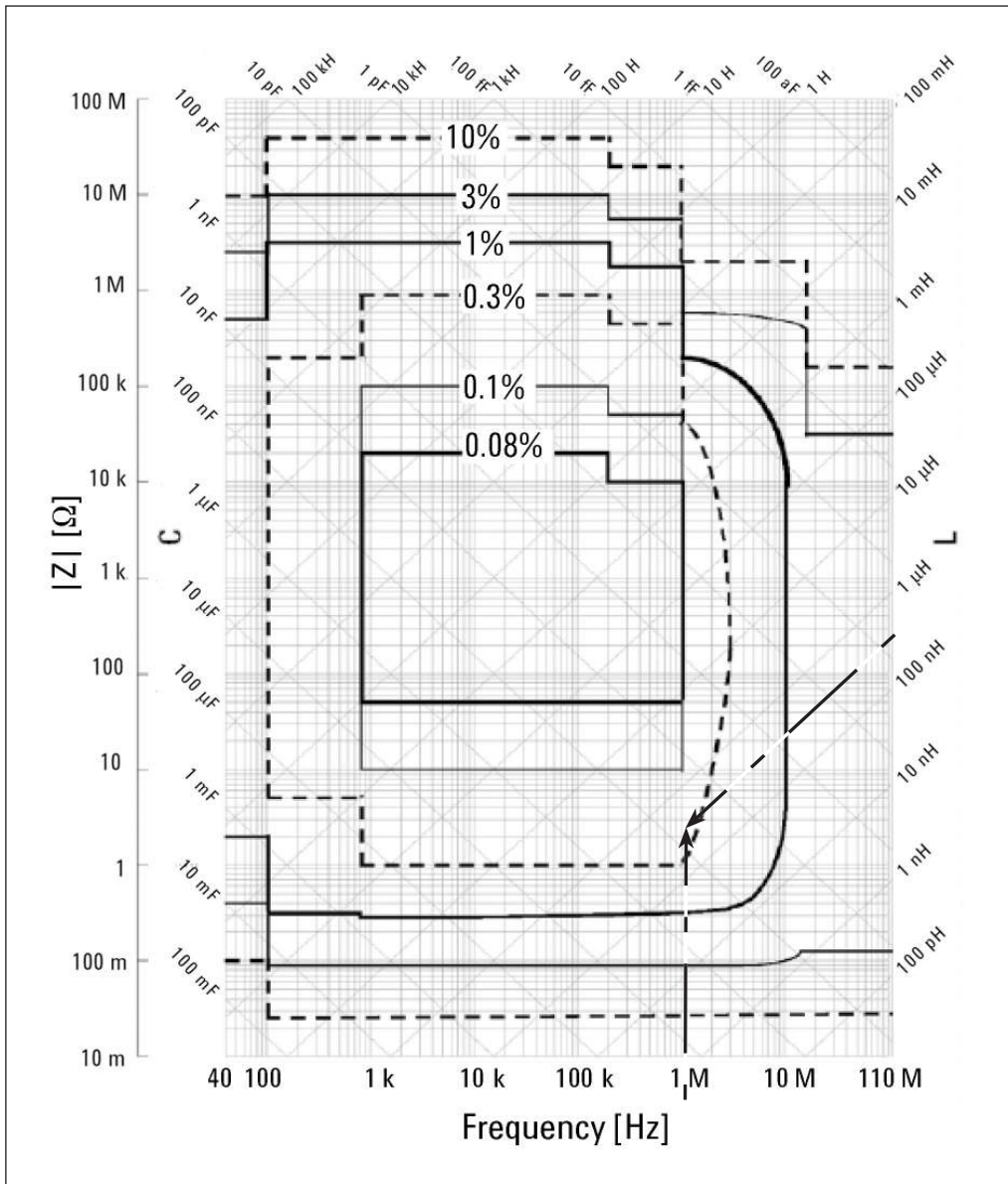


Figure 1-21. Example of measurement accuracy indicated on a reactance chart

2.0 Impedance Measurement Instruments

2.1 Measurement methods

There are many measurement methods to choose from when measuring impedance, each of which has advantages and disadvantages. You must consider your measurement requirements and conditions, and then choose the most appropriate method, while considering such factors as frequency coverage, measurement range, measurement accuracy, and ease of operation. Your choice will require you to make tradeoffs as there is not a single measurement method that includes all measurement capabilities. Figure 2-1 shows six commonly used impedance measurement methods, from low frequencies up to the microwave region. Table 2-1 lists the advantages and disadvantages of each measurement method, the Keysight instruments that are suited for making such measurements, the instruments' applicable frequency range, and the typical applications for each method. Considering only measurement accuracy and ease of operation, the auto-balancing bridge method is the best choice for measurements up to 110 MHz. For measurements from 100 MHz to 3 GHz, the RF I-V method has the best measurement capability, and from 3 GHz and up the network analysis is the recommended technique.

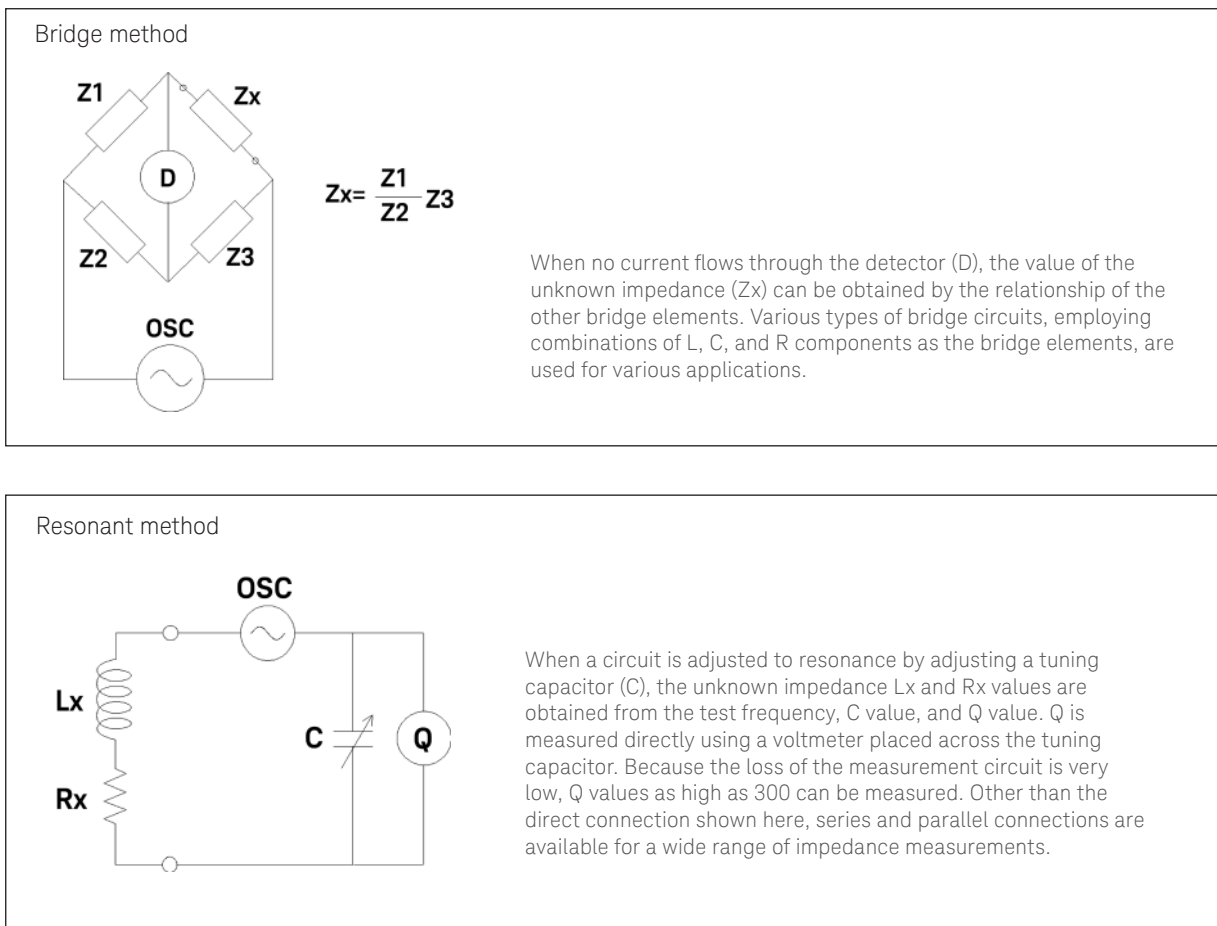


Figure 2-1. Impedance measurement method (1 of 3)

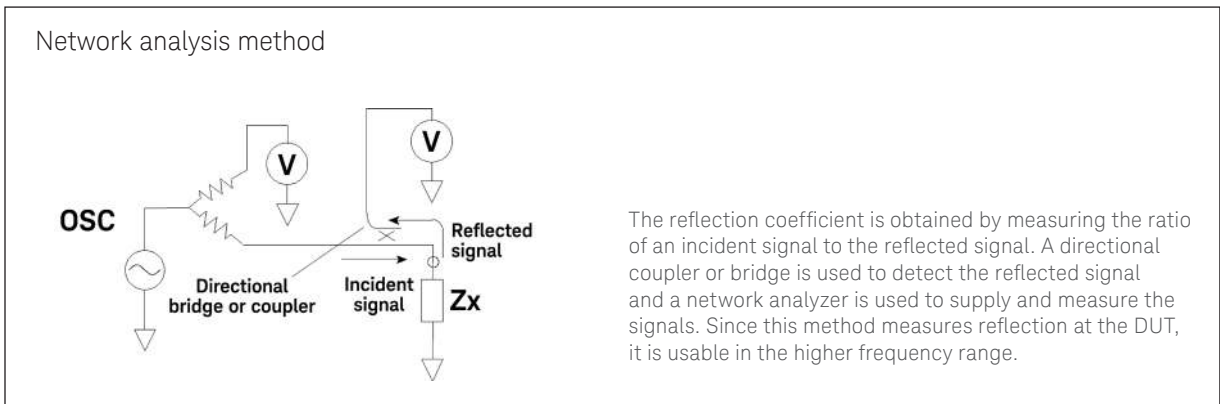
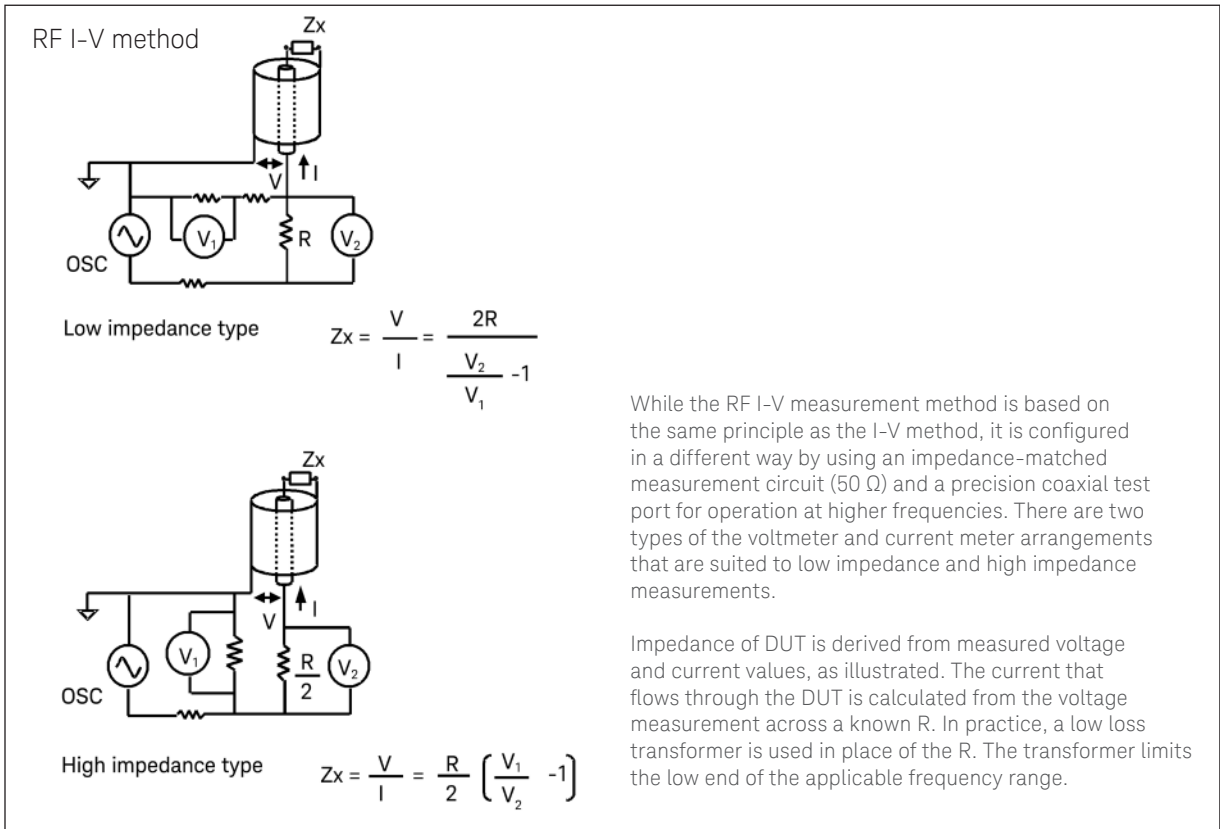
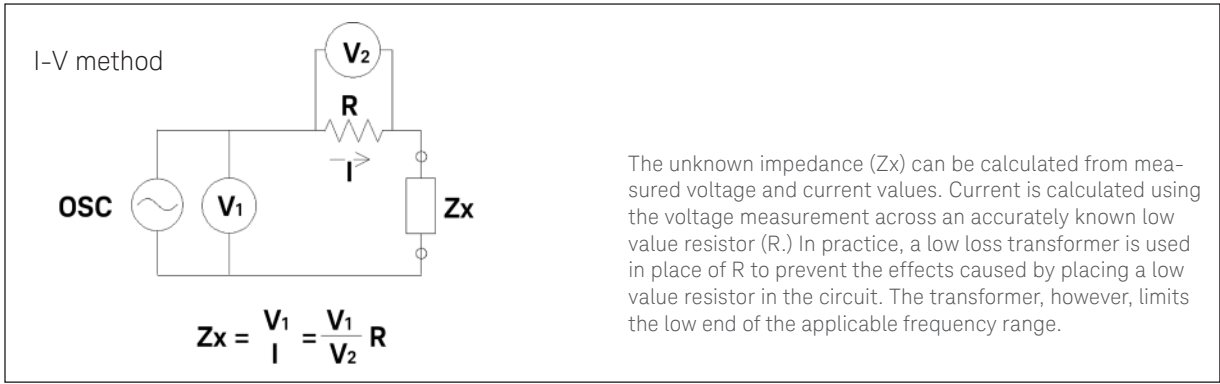


Figure 2-1. Impedance measurement method (2 of 3)

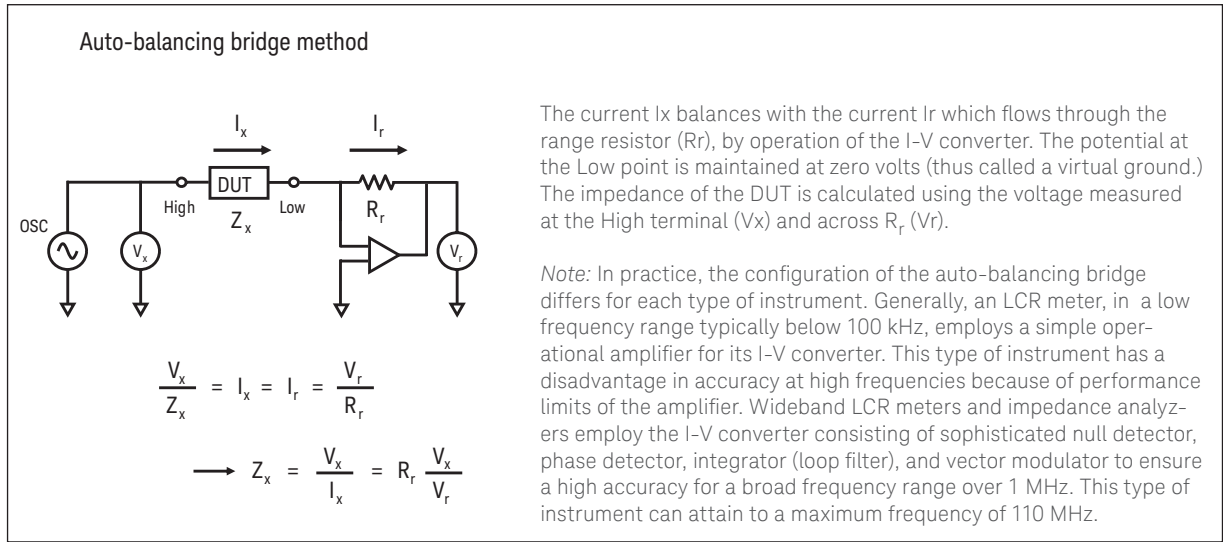


Figure 2-1. Impedance measurement method (3 of 3)

Table 2-1. Common impedance measurement methods

	Advantages	Disadvantages	Applicable frequency range	Keysight measurement instruments	Common applications
Bridge method	<ul style="list-style-type: none"> – High accuracy (0.1% typ.) – Wide frequency coverage by using different types of bridges – Low cost 	<ul style="list-style-type: none"> – Needs to be manually balanced – Narrow frequency coverage with a single instrument 	DC to 300 MHz	None	Standard lab
Resonant method	<ul style="list-style-type: none"> – Good Q accuracy up to high Q 	<ul style="list-style-type: none"> – Needs to be tuned to resonance – Low impedance measurement accuracy 	10 kHz to 70 MHz	None	High Q device measurement
I-V method	<ul style="list-style-type: none"> – Grounded device measurement – Suitable to probe-type test needs 	<ul style="list-style-type: none"> – Operating frequency range is limited by transformer used in probe 	10 kHz to 100 MHz	None	Grounded device measurement
RF I-V method	<ul style="list-style-type: none"> – High accuracy (1% typ.) and wide impedance range at high frequencies 	<ul style="list-style-type: none"> – Operating frequency range is limited by transformer used in test head 	1 MHz to 3 GHz	4287A 4395A+43961A E4991A	RF component measurement
Network analysis method	<ul style="list-style-type: none"> – High frequency range – Good accuracy when the unknown impedance is close to characteristic impedance 	<ul style="list-style-type: none"> – Recalibration required when the measurement frequency is changed – Narrow impedance measurement range 	300 kHz and above	E5071C 4395A	RF component measurement
Auto-balancing bridge method	<ul style="list-style-type: none"> – Wide frequency coverage from LF to HF – High accuracy over a wide impedance measurement range – Grounded device measurement 	<ul style="list-style-type: none"> – High frequency range not available 	20 Hz to 110 MHz	E4980A E4981A 4294A 4294A+42941A ¹ 4294A+42942A ¹	Generic component measurement 1. Grounded device measurement

Note: Keysight Technologies currently offers no instruments for the bridge method and the resonant method shaded in the above table.

2.2 Operating theory of practical instruments

The operating theory and key functions of the auto balancing bridge instrument are discussed in Sections 2.3 through 2.4. A discussion on the RF I-V instrument is described in Sections 2.5 through 2.7.

2.3 Theory of auto-balancing bridge method

The auto-balancing bridge method is commonly used in modern LF impedance measurement instruments. Its operational frequency range has been extended up to 110 MHz.

Basically, in order to measure the complex impedance of the DUT it is necessary to measure the voltage of the test signal applied to the DUT and the current that flows through it. Accordingly, the complex impedance of the DUT can be measured with a measurement circuit consisting of a signal source, a voltmeter, and an ammeter as shown in Figure 2-2 (a). The voltmeter and ammeter measure the vectors (magnitude and phase angle) of the signal voltage and current, respectively.

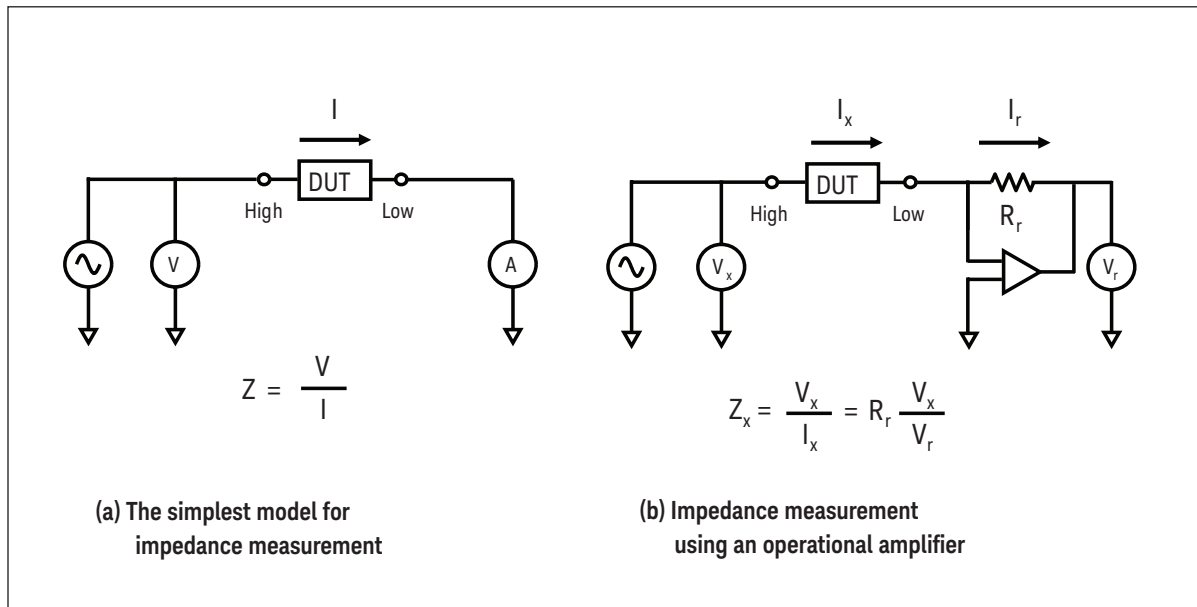


Figure 2-2. Principle of auto-balancing bridge method

The auto-balancing bridge instruments for low frequency impedance measurement (below 100 kHz) usually employ a simple I-V converter circuit (an operational amplifier with a negative feedback loop) in place of the ammeter as shown in Figure 2-2 (b). The bridge section works to measure impedance as follows:

The test signal current (I_x) flows through the DUT and also flows into the I-V converter. The operational amplifier of the I-V converter makes the same current as I_x flow through the resistor (R_r) on the negative feedback loop. Since the feedback current (I_r) is equal to the input current (I_x) flows through the R_r and the potential at the Low terminal is automatically driven to zero volts. Thus, it is called virtual ground. The I-V converter output voltage (V_r) is represented by the following equation:

$$V_r = I_r \times R_r = I_x \times R_r \tag{2-1}$$

I_x is determined by the impedance (Z_x) of the DUT and the voltage V_x across the DUT as follows:

$$I_x = \frac{V_x}{Z_x} \tag{2-2}$$

From the equations 2-1 and 2-2, the equation for impedance (Z_x) of the DUT is derived as follows:

$$Z_x = \frac{V_x}{I_x} = R_r \frac{V_x}{V_r} \tag{2-3}$$

The vector voltages V_x and V_r are measured with the vector voltmeters as shown in Figure 2-2 (b). Since the value of R_r is known, the complex impedance Z_x of the DUT can be calculated by using equation 2-3. The R_r is called the range resistor and is the key circuit element, which determines the impedance measurement range. The R_r value is selected from several range resistors depending on the Z_x of the DUT as described in Section 2.4.3.

In order to avoid tracking errors between the two voltmeters, most of the impedance measuring instruments measure the V_x and V_r with a single vector voltmeter by alternately selecting them as shown in Figure 2-3. The circuit block, including the input channel selector and the vector voltmeter, is called the vector ratio detector, whose name comes from the function of measuring the vector ratio of V_x and V_r .

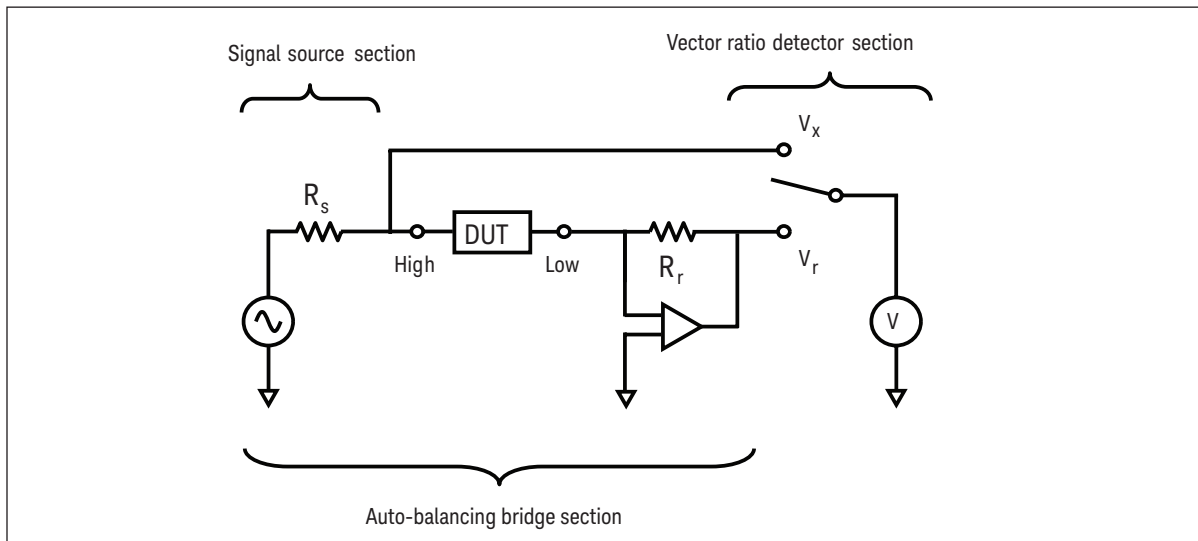


Figure 2-3. Impedance measurement using a single vector voltmeter

Note: The balancing operation that maintains the low terminal potential at zero volts has the following advantages in measuring the impedance of a DUT:

- (1) The input impedance of ammeter (I-V converter) becomes virtually zero and does not affect measurements.
- (2) Distributed capacitance of the test cables does not affect measurements because there is no potential difference between the inner and outer shielding conductors of (L_p and L_c) cables. (At high frequencies, the test cables cause measurement errors as described in Section 4.5.)
- (3) Guarding technique can be used to remove stray capacitance effects as described in Sections 2.4.7 and 3.4.

Block diagram level discussions for the signal source, auto-balancing bridge, and vector ratio detector are described in Sections 2.3.1 through 2.3.3.

2.3.1. Signal source section

The signal source section generates the test signal applied to the unknown device. The frequency of the test signal (f_m) and the output signal level are variable. The generated signal is output at the H_c terminal via a source resistor, and is applied to the DUT. In addition to generating the test signal that is fed to the DUT, the reference signals used internally are also generated in this signal source section. Figure 2-4 shows the signal source section block diagram of the Keysight 4294A precision impedance analyzer. Frequency synthesizer and frequency conversion techniques are employed to generate high-resolution test signals (1 mHz minimum resolution), as well as to expand the upper frequency limit up to 110 MHz.

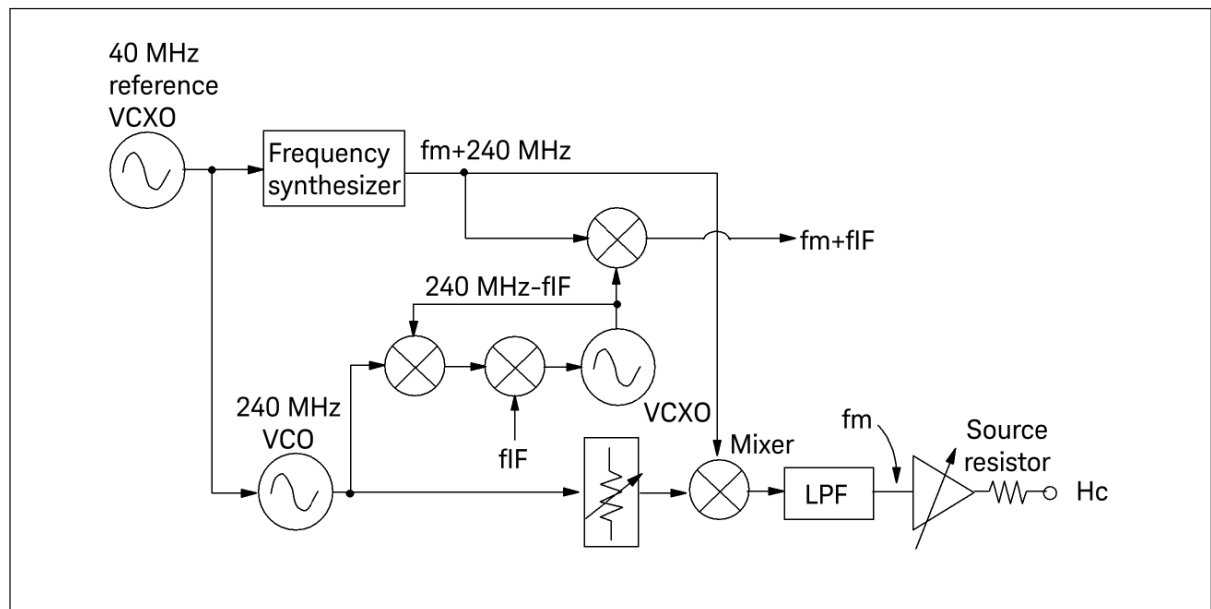


Figure 2-4. Signal source section block diagram

2.3.2 Auto-balancing bridge section

The auto-balancing bridge section balances the range resistor current with the DUT current while maintaining a zero potential at the Low terminal. Figure 2-5 (a) shows a simplified circuit model that expresses the operation of the auto-balancing bridge. If the range resistor current is not balanced with the DUT current, an unbalance current that equals $I_x - I_r$ flows into the null detector at the L_p terminal. The unbalance current vector represents how much the magnitude and phase angle of the range resistor current differ from the DUT current. The null detector detects the unbalance current and controls both the magnitude and phase angle of the OSC2 output so that the detected current goes to zero.

Low frequency instruments, below 100 kHz, employ a simple operational amplifier to configure the null detector and the equivalent of OSC2 as shown in Figure 2-5 (b). This circuit configuration cannot be used at frequencies higher than 100 kHz because of the performance limits of the operational amplifier. The instruments that cover frequencies above 100 kHz have an auto balancing bridge circuit consisting of a null detector, $0^\circ/90^\circ$ phase detectors, and a vector modulator as shown in Figure 2-5 (c). When an unbalance current is detected with the null detector, the phase detectors in the next stage separate the current into 0° and 90° vector components. The phase detector output signals go through loop filters (integrators) and are applied to the vector modulator to drive the $0^\circ/90^\circ$ component signals. The $0^\circ/90^\circ$ component signals are compounded and the resultant signal is fed back through range resistor (R_r) to cancel the current flowing through the DUT. Even if the balancing control loop has phase errors, the unbalance current component, due to the phase errors, is also detected and fed back to cancel the error in the range resistor current. Consequently, the unbalance current converges to exactly zero, ensuring $I_x = I_r$ over a broad frequency range up to 110 MHz.

If the unbalance current flowing into the null detector exceeds a certain threshold level, the unbalance detector after the null detector announces the unbalance state to the digital control section of the instrument. As a result, an error message such as “OVERLOAD” or “BRIDGE UNBALANCED” is displayed.

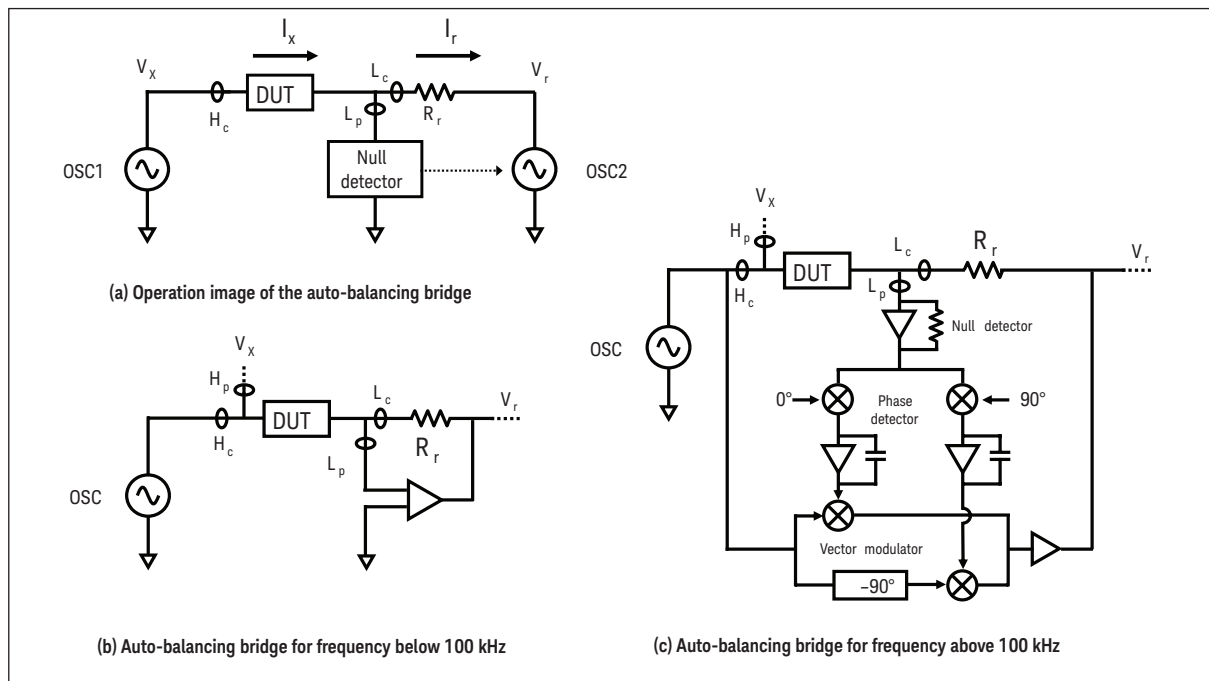


Figure 2-5. Auto-balancing bridge section block diagram

2.3.3 Vector ratio detector section

The vector ratio detector (VRD) section measures the ratio of vector voltages across the DUT, V_x , and across the range resistor (V_r) series circuit, as shown in Figure 2-6 (b). The VRD consists of an input selector switch (S), a phase detector, and an A-D converter, also shown in this diagram.) The measured vector voltages, V_x and V_r , are used to calculate the complex impedance (Z_x) in accordance with equation 2-3.

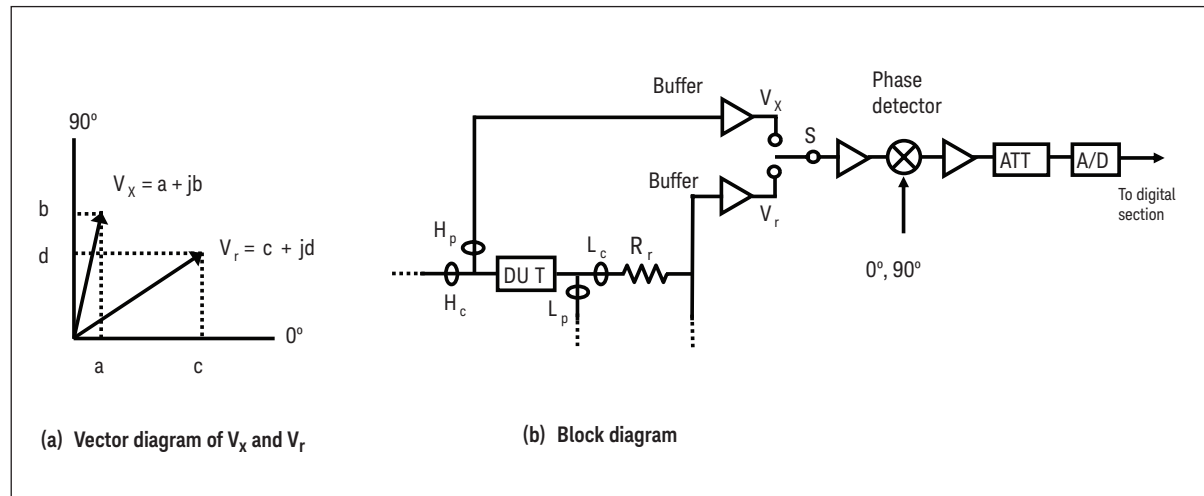


Figure 2-6. Vector ratio detector section block diagram

In order to measure the V_x and V_r , these vector signals are resolved into real and imaginary components, $V_x = a + jb$ and $V_r = c + jd$, as shown in Figure 2-6 (a). The vector voltage ratio of V_x/V_r is represented by using the vector components a , b , c , and d as follows:

$$\frac{V_x}{V_r} = \frac{a + jb}{c + jd} = \frac{ac + bd}{c^2 + d^2} + j \frac{bc - ad}{c^2 + d^2} \quad (2-4)$$

The VRD circuit is operated as follows. First, the input selector switch (S) is set to the V_x position. The phase detector is driven with 0° and 90° reference phase signals to extract the real and imaginary components (a and jb) of the V_x signal. The A-D converter next to the phase detector outputs digital data for the magnitudes of a and jb . Next, S is set to the V_r position. The phase detector and the A-D converter perform the same for the V_r signal to extract the real and imaginary components (c and jd) of the V_r signal.

From the equations 2-3 and 2-4, the equation that represents the complex impedance Z_x of the DUT is derived as follows (equation 2-5):

$$Z_x = R_x + jX_x = R_r \frac{V_x}{V_r} = R_r \left[\frac{ac + bd}{c^2 + d^2} + j \frac{bc - ad}{c^2 + d^2} \right] \quad (2-5)$$

The resistance and the reactance of the DUT are thus calculated as:

$$R_x = R_r \frac{ac + bd}{c^2 + d^2}, \quad X_x = R_r \frac{bc - ad}{c^2 + d^2} \quad (2-6)$$

Various impedance parameters (C_p , C_s , L_p , L_s , D , Q , etc) are calculated from the measured R_x and X_x values by using parameter conversion equations which are described in Section 1.

2.4 Key measurement functions

The following discussion describes the key measurement functions for advanced impedance measurement instruments. Thoroughly understanding these measurement functions will eliminate the confusion sometimes caused by the measurement results obtained.

2.4.1 Oscillator (OSC) level

The oscillator output signal is output through the Hc terminal and can be varied to change the test signal level applied to the DUT. The specified output signal level, however, is not always applied directly to the DUT. In general, the specified OSC level is obtained when the High terminal is open. Since source resistor (R_s) is connected in series with the oscillator output, as shown in Figure 2-7, there is a voltage drop across R_s . So, when the DUT is connected, the applied voltage (V_x) depends on the value of the source resistor and the DUT's impedance value. This must be taken into consideration especially when measuring low values of impedance (low inductance or high capacitance). The OSC level should be set as high as possible to obtain a good signal-to-noise (S/N) ratio for the vector ratio detector section. A high S/N ratio improves the accuracy and stability of the measurement. In some cases, however, the OSC level should be decreased, such as when measuring core-inductors, and when measuring semiconductor devices in which the OSC level is critical for the measurement and to the device itself.

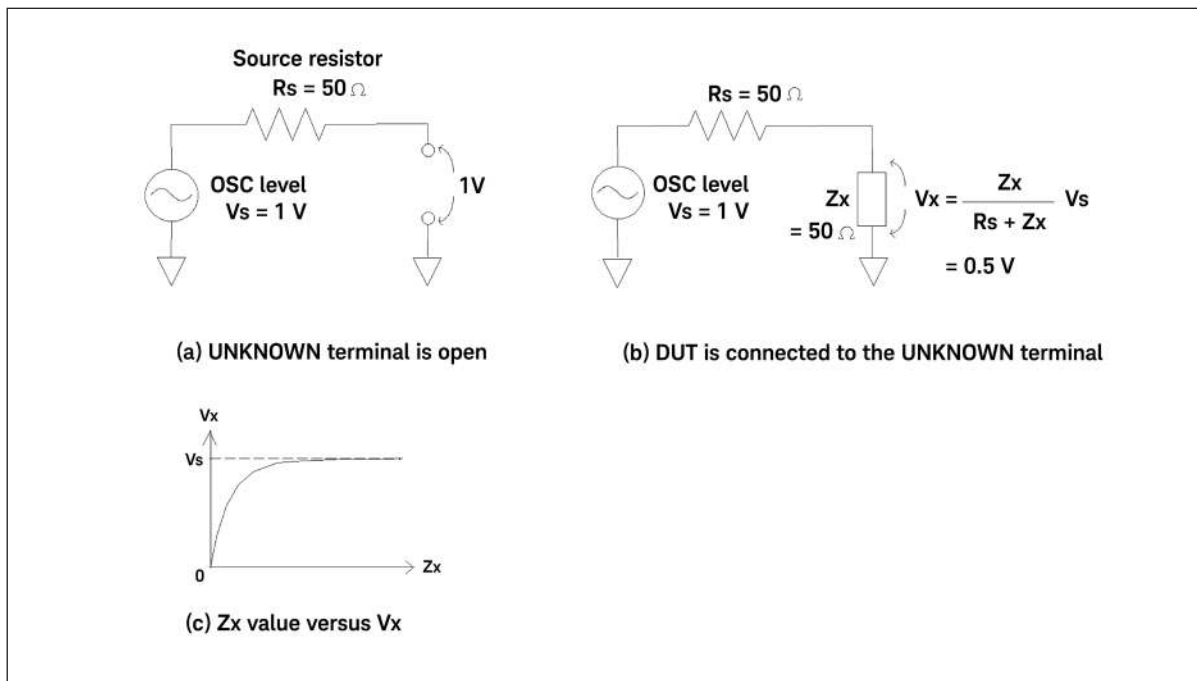


Figure 2-7. OSC level divided by source resistor (R_s) and DUT impedance (Z_x)

2.4.2 DC bias

In addition to the AC test signal, a DC voltage can be output through the Hc terminal and applied to the DUT. A simplified output circuit, with a DC bias source, is shown in Figure 2-8. Many of the conventional impedance measurement instruments have a voltage bias function, which assumes that almost no bias current flows (the DUT has a high resistance.) If the DUT's DC resistance is low, a bias current flows through the DUT and into the resistor (R_r) thereby raising the DC potential of the virtual ground point. Also, the bias voltage is dropped at source resistor (R_s .) As a result, the specified bias voltage is not applied to the DUT and, in some cases, it may cause measurement error. This must be taken into consideration when a low-resistivity semiconductor device is measured.

The Keysight 4294A precision impedance analyzer (and some other impedance analyzers) has an advanced DC bias function that can be set to either voltage source mode or current source mode. Because the bias output is automatically regulated according to the monitored bias voltage and current, the actual bias voltage or current applied across the DUT is always maintained at the setting value regardless of the DUT's DC resistance. The bias voltage or current can be regulated when the output is within the specified compliance range.

Inductors are conductive at DC. Often a DC current dependency of inductance needs to be measured. Generally the internal bias output current is not enough to bias the inductor at the required current levels. To apply a high DC bias current to the DUT, an external current bias unit or adapter can be used with specific instruments. The 42841A and its bias accessories are available for high current bias measurements using the Keysight E4980A, 4284A, and 4285A precision LCR meters.

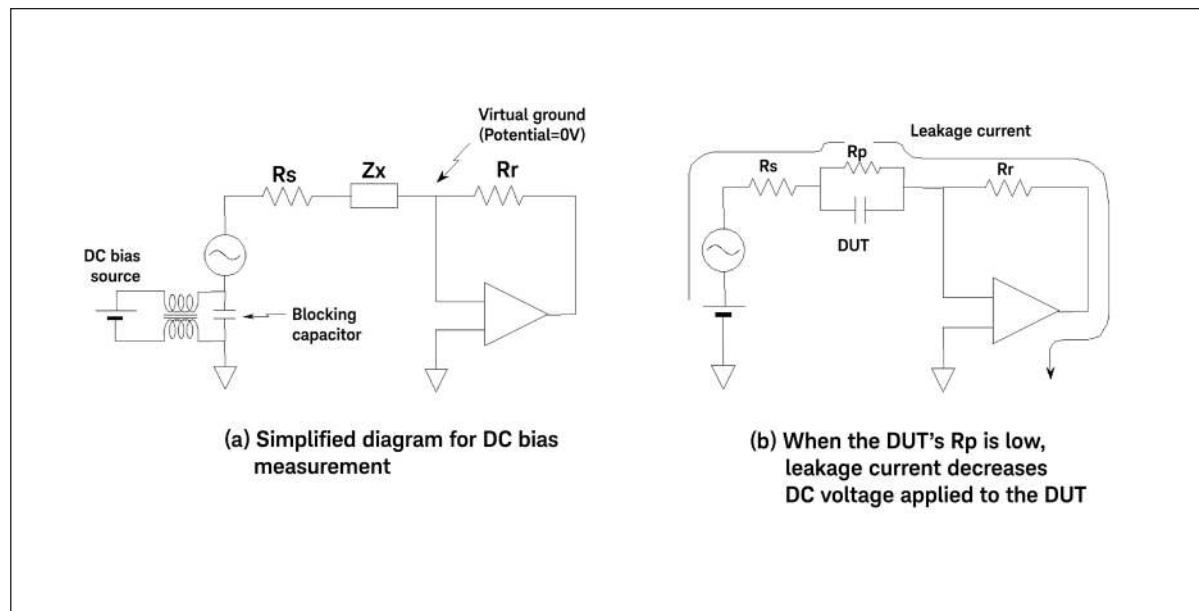


Figure 2-8. DC bias applied to DUT referenced to virtual ground

2.4.3 Ranging function

To measure impedance from low to high values, impedance measurement instruments have several measurement ranges. Generally, seven to ten measurement ranges are available and the instrument can automatically select the appropriate measurement range according to the DUT's impedance. Range changes are generally accomplished by changing the gain multiplier of the vector ratio detector, and by switching the range resistor (Figure 2-9 (a).) This insures that the maximum signal level is fed into the analog-to-digital (A-D) converter to give the highest S/N ratio for maximum measurement accuracy.

The range boundary is generally specified at two points to give an overlap between adjacent ranges. Range changes occur with hysteresis as shown in Figure 2-9 (b), to prevent frequent range changes due to noise.

On any measurement range, the maximum accuracy is obtained when the measured impedance is close to the full-scale value of the range being used. Conversely, if the measured impedance is much lower than the full-scale value of the range being used, the measurement accuracy will be degraded. This sometimes causes a discontinuity in the measurement values at the range boundary. To prevent this, the impedance range should be set manually to the range which measures higher impedance.

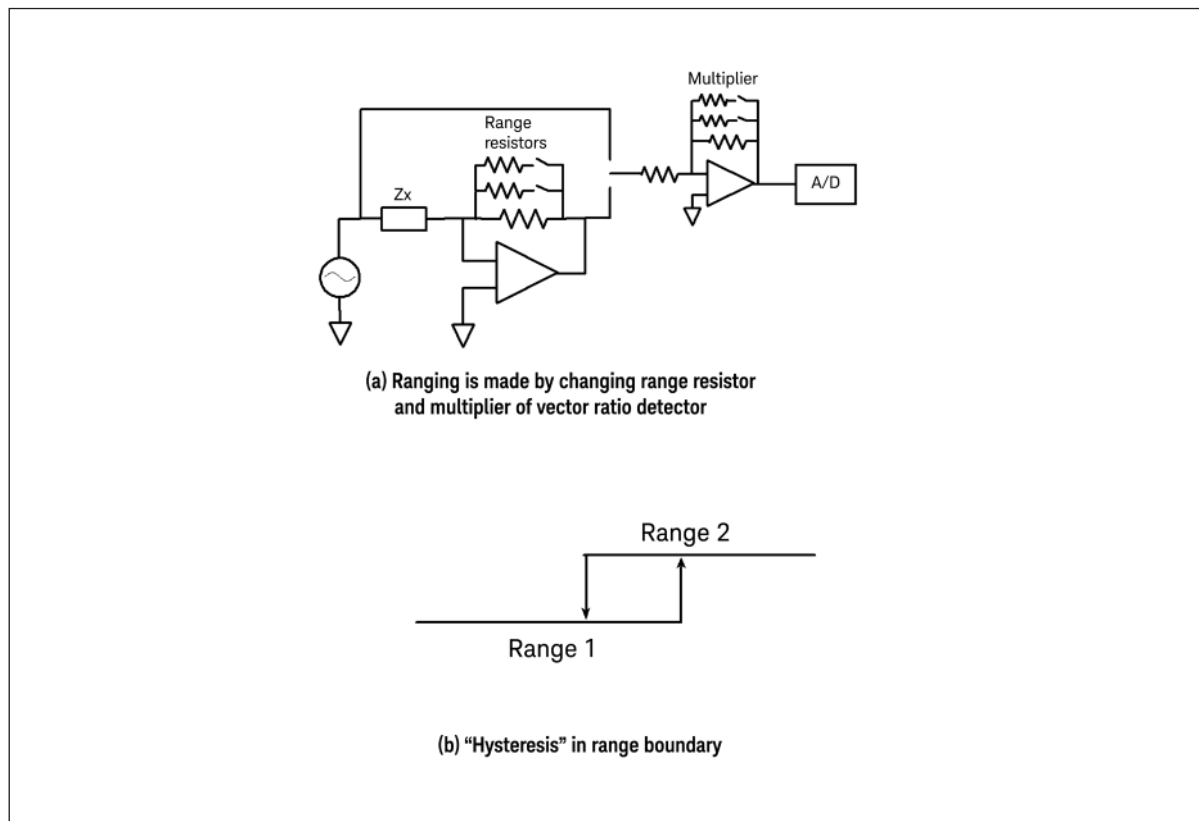


Figure 2-9. Ranging function

2.4.4 Level monitor function

Monitoring the test signal voltage or current applied to the DUT is important for maintaining accurate test conditions, especially when the DUT has a test signal level dependency. The level monitor function measures the actual signal level across the DUT. As shown in Figure 2-10, the test signal voltage is monitored at the High terminal and the test signal current is calculated using the value of range resistor (R_r) and the voltage across it.

Instruments equipped with an auto level control (ALC) function can automatically maintain a constant test signal level. By comparing the monitored signal level with the test signal level setting value, the ALC adjusts the oscillator output until the monitored level meets the setting value. There are two ALC methods: analog and digital. The analog type has an advantage in providing a fast ALC response, whereas the digital type has an advantage in performing a stable ALC response for a wide range of DUT impedance (capacitance and inductance.)

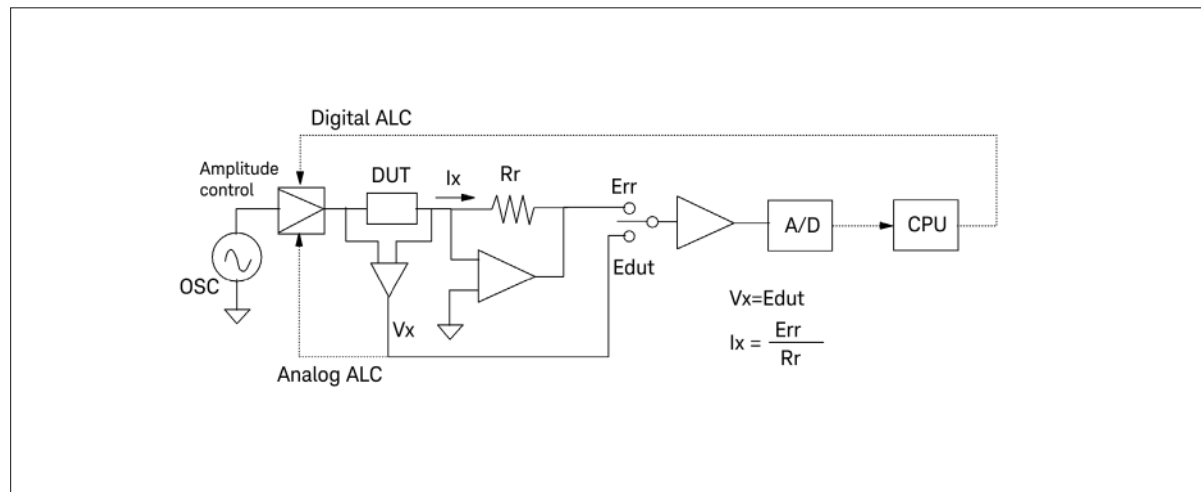


Figure 2-10. Test signal level monitor and ALC function

2.4.5 Measurement time and averaging

Achieving optimum measurement results depends upon measurement time, which may vary according to the control settings of the instrument (frequency, IF bandwidth, etc.) When selecting the measurement time modes, it is necessary to take some tradeoffs into consideration. Speeding up measurement normally conflicts with the accuracy, resolution, and stability of measurement results. The measurement time is mainly determined by operating time (acquisition time) of the A-D converter in the vector ratio detector. To meet the desired measurement speed, modern impedance measurement instruments use a high speed sampling A-D converter, in place of the previous technique, which used a phase detector and a dual-slope A-D converter. Measurement time is proportional to the number of sampling points taken to convert the analog signal ($Edut$ or Err) into digital data for each measurement cycle. Selecting a longer measurement time results in taking a greater number of sampling points for more digital data, thus improving measurement precision. Theoretically, random noise (variance) in a measured value proportionately decreases inversely to the square root of the A-D converter operating time.

Averaging function calculates the mean value of measured parameters from the desired number of measurements. Averaging has the same effect on random noise reduction as that by using a long measurement time.

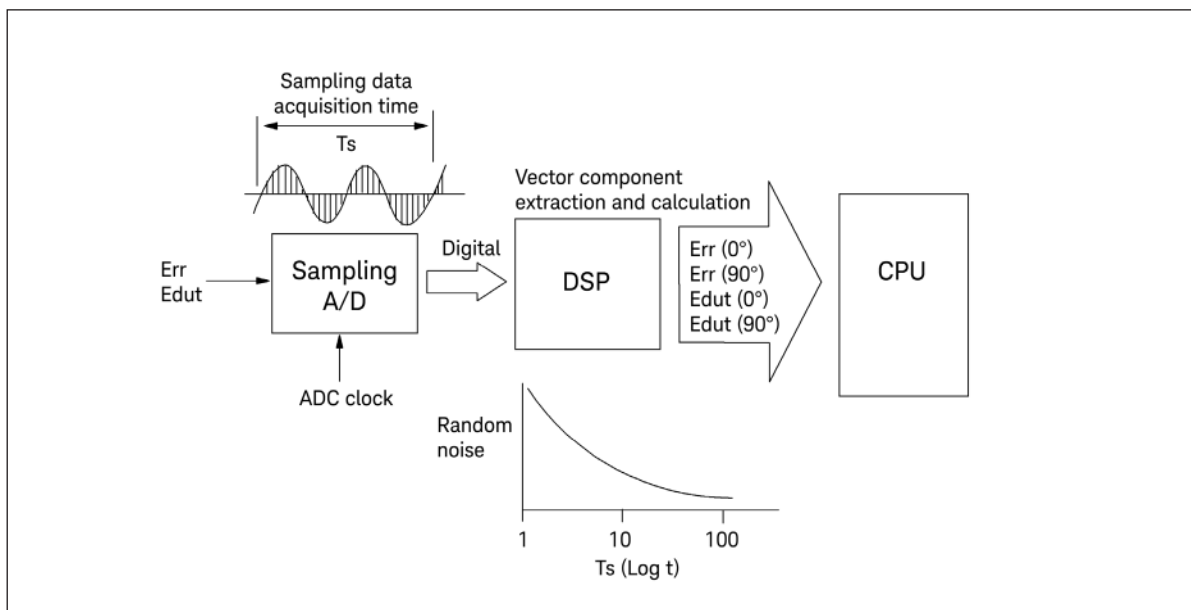


Figure 2-11. Relationship of measurement time and precision

2.4.6 Compensation function

Impedance measurement instruments are calibrated at UNKNOWN terminals and measurement accuracy is specified at the calibrated reference plane. However, an actual measurement cannot be made directly at the calibration plane because the UNKNOWN terminals do not geometrically fit to the shapes of components that are to be tested. Various types of test fixtures and test leads are used to ease connection of the DUT to the measurement terminals. (The DUT is placed across the test fixture's terminals, not at the calibration plane.) As a result, a variety of error sources (such as residual impedance, admittance, electrical length, etc.) are involved in the circuit between the DUT and the UNKNOWN terminals. The instrument's compensation function eliminates measurement errors due to these error sources. Generally, the instruments have the following compensation functions:

- Open/short compensation or open/short/load compensation
- Cable length correction

The open/short compensation function removes the effects of the test fixture's residuals. The open/short/load compensation allows complicated errors to be removed where the open/short compensation is not effective. The cable length correction offsets the error due to the test lead's transmission characteristics.

The induced errors are dependent upon test frequency, test fixture, test leads, DUT connection configuration, and surrounding conditions of the DUT. Hence, the procedure to perform compensation with actual measurement setup is the key to obtaining accurate measurement results. The compensation theory and practice are discussed comprehensively in Section 4.

2.4.7 Guarding

When in-circuit measurements are being performed or when one parameter of a three-terminal device is to be measured for the targeted component, as shown in Figure 2-12 (a), the effects of paralleled impedance can be reduced by using guarding techniques. The guarding techniques can also be utilized to reduce the outcome of stray capacitance when the measurements are affected by the strays present between the measurement terminals, or between the DUT terminals and a closely located conductor. (Refer to Section 3.5 for the methods of eliminating the stray capacitance effects.)

The guard terminal is the circuit common of the auto-balancing bridge and is connected to the shields of the four-terminal pair connectors. The guard terminal is electrically different from the ground terminal, which is connected directly to the chassis (Figure 2-12 (b).) When the guard is properly connected, as shown in Figure 2-12 (c), it reduces the test signal's current but does not affect the measurement of the DUT's impedance (Z_x) because Z_x is calculated using DUT current (I_x .)

The details of the guard effects are described as follows. The current (I_1) which flows through Z_1 , does not flow into the ammeter. As long as I_1 does not cause a significant voltage drop of the applied test signal, it scarcely influences on measurements. The current I_2 , which is supposed to flow through Z_2 , is small and negligible compared to I_x , because the internal resistance of the ammeter (equivalent input impedance of the auto-balancing bridge circuit) is very low in comparison to Z_2 . In addition, the potential at the Low terminal of the bridge circuit, in the balanced condition, is zero (virtual ground.) However, if Z_2 is too low, the measurement will become unstable because ammeter noise increases.

Note: In order to avoid possible bridge unbalance and not cause significant measurement errors, Z_2 should not be lower than certain impedance. Minimum allowable value of Z_2 depends on Z_x , test cable length, test frequency, and other measurement conditions.

The actual guard connection is shown in Figure 2-12 (d). The guard lead impedance (Z_g) should be as small as possible. If Z_g is not low enough, an error current will flow through the series circuit of Z_1 and Z_2 and, it is parallel with I_x .

Note: Using the ground terminal in place of the guard terminal is not recommend because the ground potential is not the true zero reference potential of the auto-balancing bridge circuit. Basically, the ground terminal is used to interconnect the ground (chassis) of the instrument and that of a system component, such as an external bias source or scanner, in order to prevent noise interference that may be caused by mutual ground potential difference.

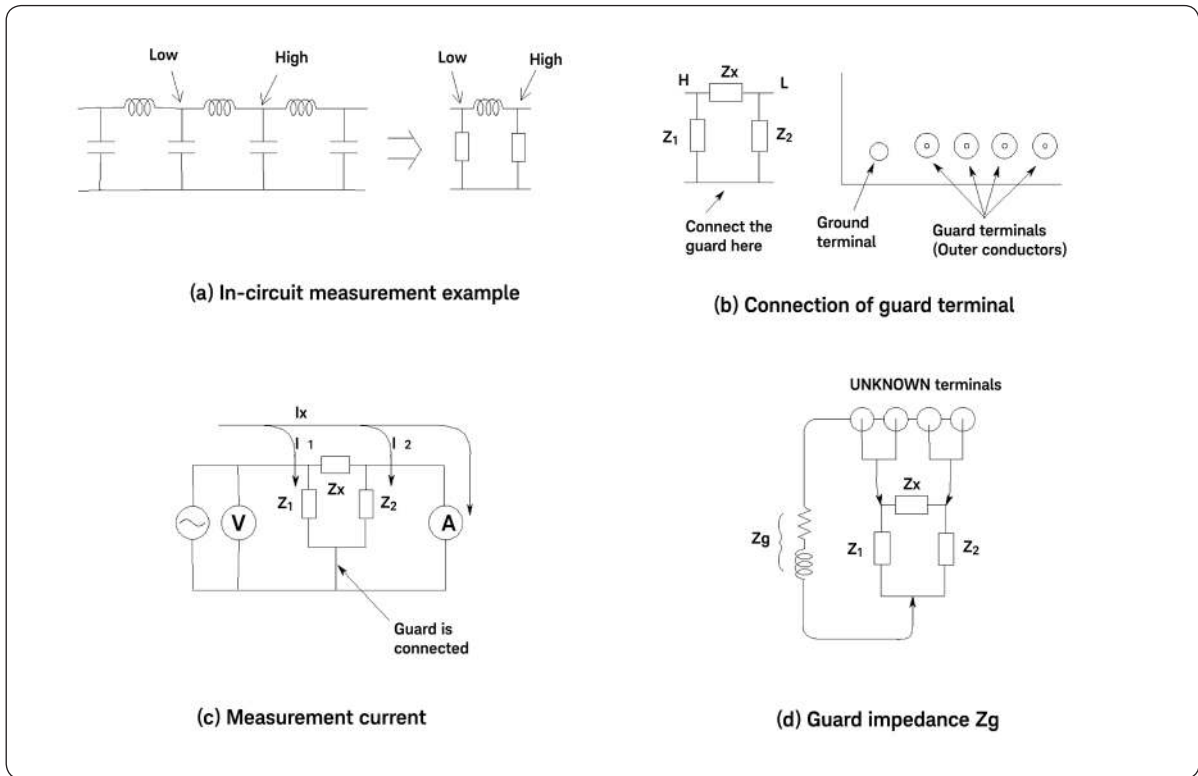


Figure 2-12. Guarding techniques

2.4.8 Grounded device measurement capability

Grounded devices such as the input/output of an amplifier can be measured directly using the I-V measurement method or the reflection coefficient measurement method (Figure 2-13 (a).) However, it is difficult for an auto-balancing bridge to measure low-grounded devices because the measurement signal current bypasses the ammeter (Figure 2-13 (b).) Measurement is possible only when the chassis ground is isolated from the DUT's ground. (Note: The 4294A used with the Keysight 42941A impedance probe kit or the Keysight 42942A terminal adapter will result in grounded measurements.)

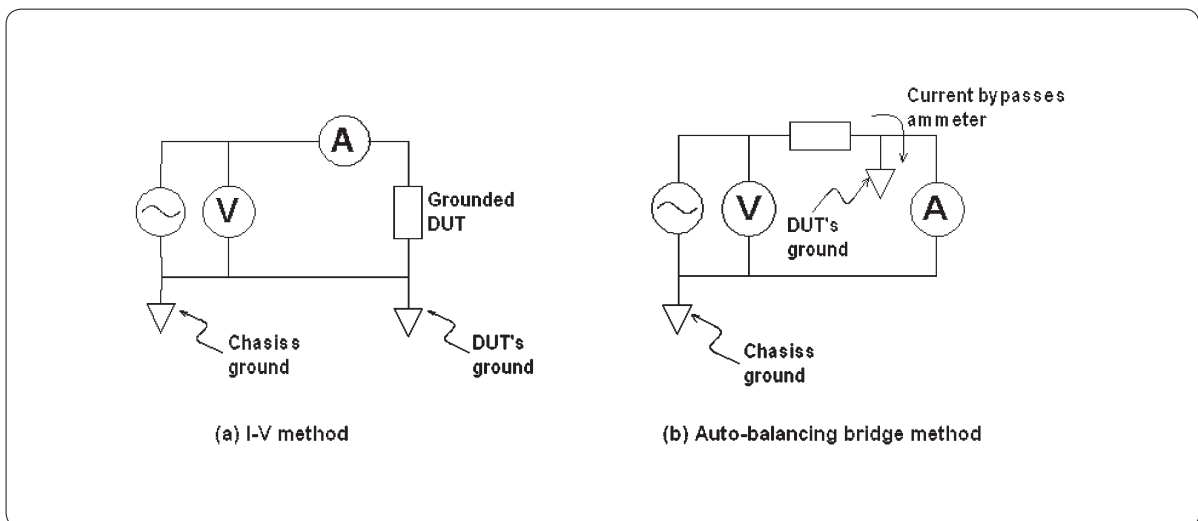


Figure 2-13. Low-grounded device measurement

2.5 Theory of RF I-V measurement method

The RF I-V method featuring Keysight's RF impedance analyzers and RF LCR meters is an advanced technique to measure impedance parameters in the high frequency range, beyond the frequency coverage of the auto-balancing bridge method. It provides better accuracy and a wider impedance range than the network analysis (reflection coefficient measurement) instruments can offer. This section discusses the brief operating theory of the RF I-V method using a simplified block diagram as shown in Figure 2-14.

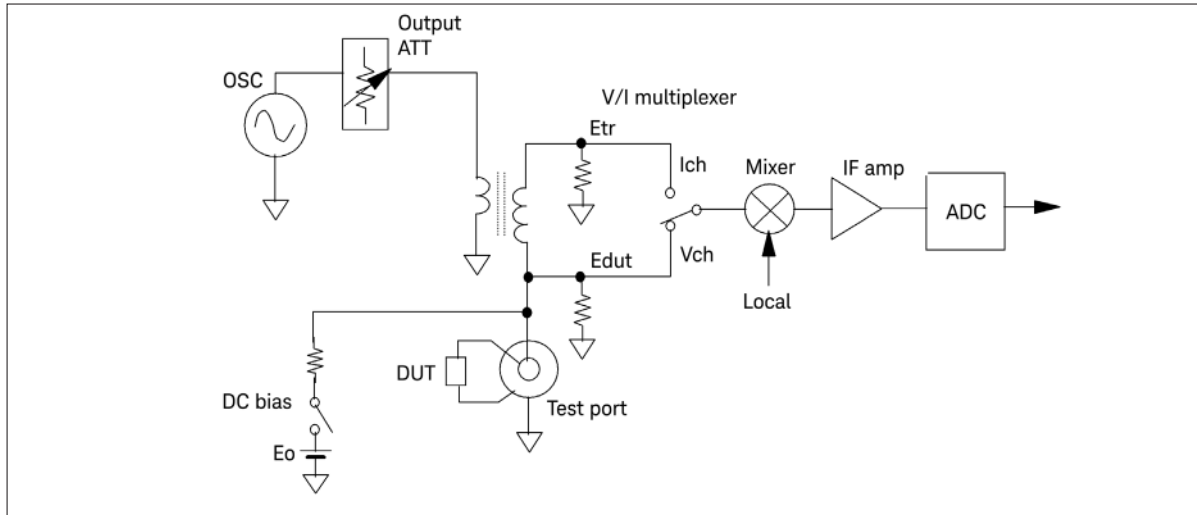


Figure 2-14. Simplified block diagram for RF I-V method

The signal source section generates an RF test signal applied to the unknown device and typically has a variable frequency range from 1 MHz to 3 GHz. Generally, a frequency synthesizer is used to meet frequency accuracy, resolution, and sweep function needs. The amplitude of signal source output is adjusted for the desired test level by the output attenuator.

The test head section is configured with a current detection transformer, V/I multiplexer, and test port. The measurement circuit is matched to the characteristic impedance of 50 Ω to ensure optimum accuracy at high frequencies. The test port also employs a precision coaxial connector of 50 Ω characteristic impedance. Since the test current flows through the transformer in series with the DUT connected to the test port, it can be measured from the voltage across the transformer's winding. The V channel signal, E_{dut} , represents the voltage across the DUT and the I channel signal (E_{tr}) represents the current flowing through the DUT. Because the measurement circuit impedance is fixed at 50 Ω , all measurements are made in reference to 50 Ω without ranging operation.

The vector ratio detector section has similar circuit configurations as the auto-balancing bridge instruments. The V/I input multiplexer alternately selects the E_{dut} and E_{tr} signals so that the two vector voltages are measured with an identical vector ratio detector to avoid tracking errors. The measuring ratio of the two voltages derives the impedance of the unknown device as $Z_x = 50 \times (E_{dut}/E_{tr})$. To make the vector measurement easier, the mixer circuit down-converts the frequency of the E_{dut} and E_{tr} signals to an IF frequency suitable for the A-D converter's operating speed. In practice, double or triple IF conversion is used to obtain spurious-free IF signals. Each vector voltage is converted into digital data by the A-D converter and is digitally separated into 0° and 90° vector components.

2.6 Difference between RF I-V and network analysis measurement methods

When testing components in the RF region, the RF I-V measurement method is often compared with network analysis. The difference, in principle, is highlighted as the clarifying reason why the RF I-V method has advantages over the reflection coefficient measurement method, commonly used with network analysis.

The network analysis method measures the reflection coefficient value (Γ_x) of the unknown device. Γ_x is correlated with impedance, by the following equation:

$$\Gamma_x = (Z_x - Z_0)/(Z_x + Z_0)$$

Where, Z_0 is the characteristic impedance of the measurement circuit (50 Ω) and Z_x is the DUT impedance. In accordance with this equation, measured reflection coefficient varies from -1 to 1 depending on the impedance (Z_x .) The relationship of the reflection coefficient to impedance is graphically shown in Figure 2-15. The reflection coefficient curve in the graph affirms that the DUT is resistive. As Figure 2-15 indicates, the reflection coefficient sharply varies, with difference in impedance (ratio), when Z_x is near Z_0 (that is, when Γ_x is near zero). The highest accuracy is obtained at Z_x equal to Z_0 because the directional bridge for measuring reflection detects the “null” balance point. The gradient of reflection coefficient curve becomes slower for lower and higher impedance, causing deterioration of impedance measurement accuracy. In contrast, the principle of the RF I-V method is based on the linear relationship of the voltage-current ratio to impedance, as given by Ohm’s law. Thus, the theoretical impedance measurement sensitivity is constant, regardless of measured impedance (Figure 2-16 (a).) The RF I-V method has measurement sensitivity that is superior to the reflection coefficient measurement except for a very narrow impedance range around the null balance point ($\Gamma = 0$ or $Z_x = Z_0$) of the directional bridge.

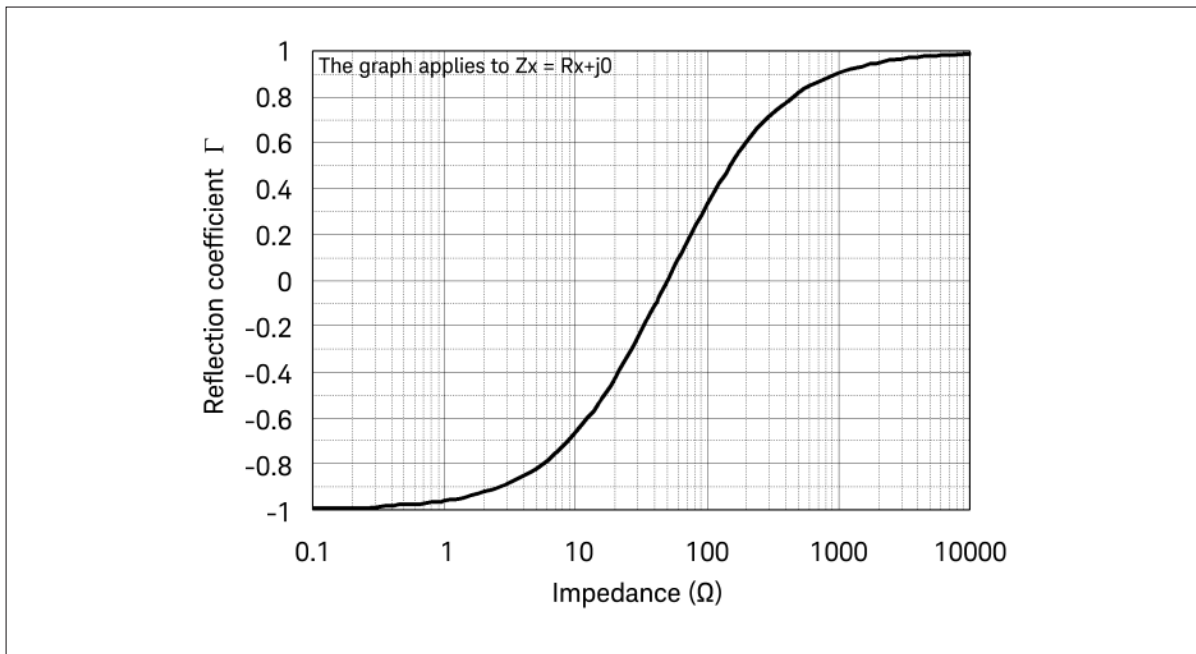


Figure 2-15. Relationship of reflection coefficient to impedance

Note: Measurement sensitivity is a change in measured signal levels ($\Delta V/I$ or $\Delta V/V$) relative to a change in DUT impedance ($\Delta Z/Z$.) The measurement error approximates to the inverse of the sensitivity.

The reflection coefficient measurement never exhibits such high peak sensitivity for capacitive and inductive DUTs because the directional bridge does not have the null balance point for reactive impedance. The measurement sensitivity of the RF I-V method also varies, depending on the DUT's impedance, because the measurement circuit involves residuals and the voltmeter and current meter are not ideal (Figure 2-16 (b).) (Voltmeter and current meter arrangement influences the measurement sensitivity.) Though the measurable impedance range of the RF I-V method is limited by those error sources, it can cover a wider range than in the network analysis method. The RF I-V measurement instrument provides a typical impedance range from 0.2 Ω to 20 k Ω at the calibrated test port, while the network analysis is typically from 2 Ω to 1.5 k Ω (depending upon the required accuracy and measurement frequency.)

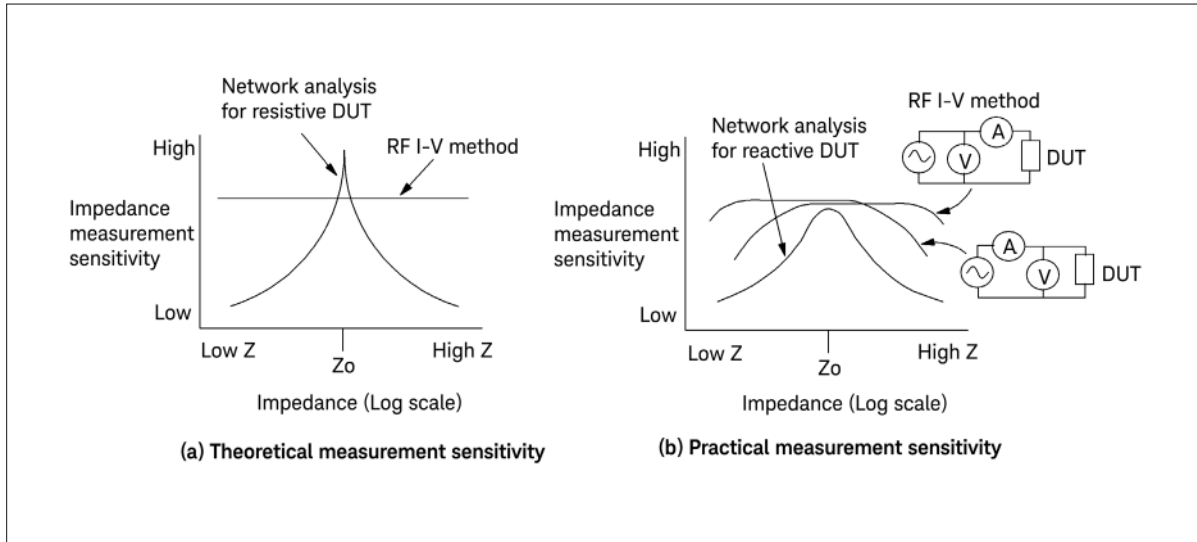


Figure 2-16. Measurement sensitivity of network analysis and RF I-V methods

Note: Typical impedance range implies measurable range within 10 percent accuracy.

Moreover, because the vector ratio measurement is multiplexed to avoid phase tracking error and, because calibration referenced to a low loss capacitor can be used, accurate and stable measurement of a low dissipation factor (high Q factor) is enabled. The Q factor accuracy of the network analysis and the RF I-V methods are compared in Figure 2-17.

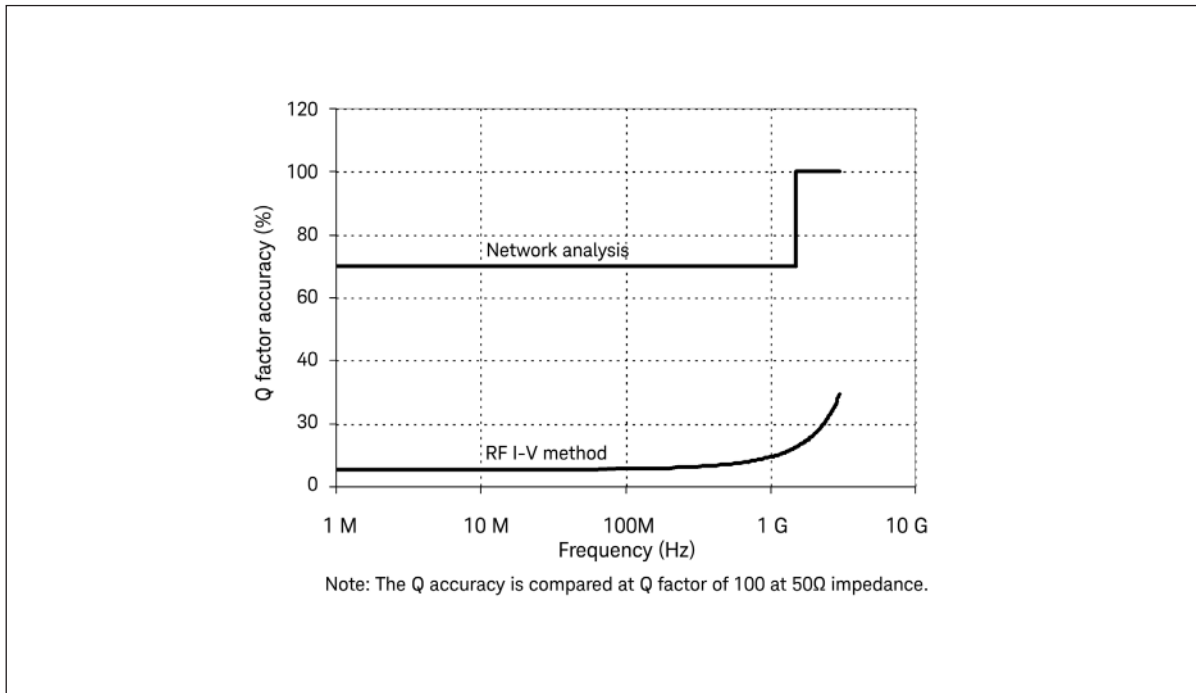


Figure 2-17. Comparison of typical Q accuracy

2.7 Key measurement functions

2.7.1 OSC level

The oscillator output signal is output through the coaxial test port (coaxial connector) with a source impedance of 50 Ω. The oscillator output level can be controlled to change the test signal level applied to the DUT. Specified test signal level is obtained when the connector is terminated with a 50 Ω load (the signal level for open or short condition is calculated from that for 50 Ω.) When a DUT is connected to the measurement terminals, the current that flows through the DUT will cause a voltage drop at the 50 Ω source impedance (resistive.) The actual test signal level applied to the device can be calculated from the source impedance and the DUT's impedance as shown in Figure 2-7. Those instruments equipped with a level monitor function can display the calculated test signal level and measurement results.

2.7.2 Test port

The test port of the RF I-V instrument usually employs a precision coaxial connector to ensure optimum accuracy throughout the high frequency range. The coaxial test port allows RF test fixtures to be attached and the instrument to be calibrated using traceable coaxial standard terminations. The test port is a two-terminal configuration and does not have a guard terminal separate from a ground terminal. Therefore, the guarding technique does not apply as well to the RF I-V measurements as compared to network analysis.

2.7.3 Calibration

Most of the RF vector measurement instruments, such as network analyzers, need to be calibrated each time a measurement is initiated or a frequency setting is changed. The RF I-V measurement instrument requires calibration as well. At higher frequencies, a change in the instrument's operating conditions, such as environmental temperature, humidity, frequency setting, etc., have a greater effect on measurement accuracy. This nature of RF vector measurement makes it difficult to sufficiently maintain the calibrated measurement performance over a long period of time. Thus, users have to periodically perform requisite calibration.

Note: Calibration is necessary each time a measurement setup is changed.

Calibration is executed in reference to three standard terminations: open, short, and load. All three must be performed. To improve the accuracy of low dissipation factor measurements (high Q factor), calibration with a low-loss capacitor can be performed. The theory of calibration and appropriate calibration methods are discussed in Section 4.

2.7.4 Compensation

Two kinds of compensation functions are provided: open/short compensation for eliminating the errors due to test fixture residuals, and electrical length compensation for minimizing the test port extension induced error. Practical compensation methods are discussed in Section 4.

2.7.5 Measurement range

The RF I-V measurement method, as well as network analysis, covers the full measurement range from low impedance to high impedance without ranging operation. All measurements are made at single broad range.

2.7.6 DC bias

The internal DC bias source is connected to the center conductor of the coaxial test port and applies a bias voltage to the DUT. The internal bias function can be set to either the voltage source mode or the current source mode. The voltage source mode is adequate to the voltage-biased measurement of the capacitive DUT. The current source mode is to the current-biased measurement of the inductive DUT. Actual bias voltage and current across the DUT are monitored and, within specified voltage/current output compliance ranges, automatically regulated at the same level as the bias setting value regardless of the DUT's DC resistance, thus allowing accurate DC bias to be applied across the DUT. Since the internal bias source cannot output bias current large enough for inductor measurements, generally, current-biased measurement (in excess of maximum output current) requires an external bias method be used. For biasing up to 5 A and 40 V in a frequency range below 1 GHz, the Keysight 16200B external DC bias adapter compatible with RF I-V instruments is available.

3.0 Fixturing and Cabling

Connecting a DUT to the measurement terminals of the auto-balancing bridge instrument requires a test fixture or test cables. The selection of the appropriate test fixtures and cables, as well as the techniques for obtaining the optimum DUT connection configuration, are important for maximizing the total measurement accuracy. This section introduces the basic theory and use of each connection configuration, focusing on the auto-balancing bridge instrument. In RF impedance measurements, the usable connection configuration is the two-terminal (2T) configuration only. Since the measurement technique for RF impedance is different from that for LF, it is described separately after the discussion of the auto-balancing bridge instrument.

3.1 Terminal configuration

An auto-balancing bridge instrument is generally equipped with four BNC connectors, H_{cur} , H_{pot} , L_{pot} , and L_{cur} , as measurement terminals (see Figure 3-1.) These terminals are conventionally named "UNKNOWN" terminals. There are several connection configurations used to interconnect a DUT with the UNKNOWN terminals. Because each method has advantages and disadvantages, the most suitable method should be selected based on the DUT's impedance and required measurement accuracy.

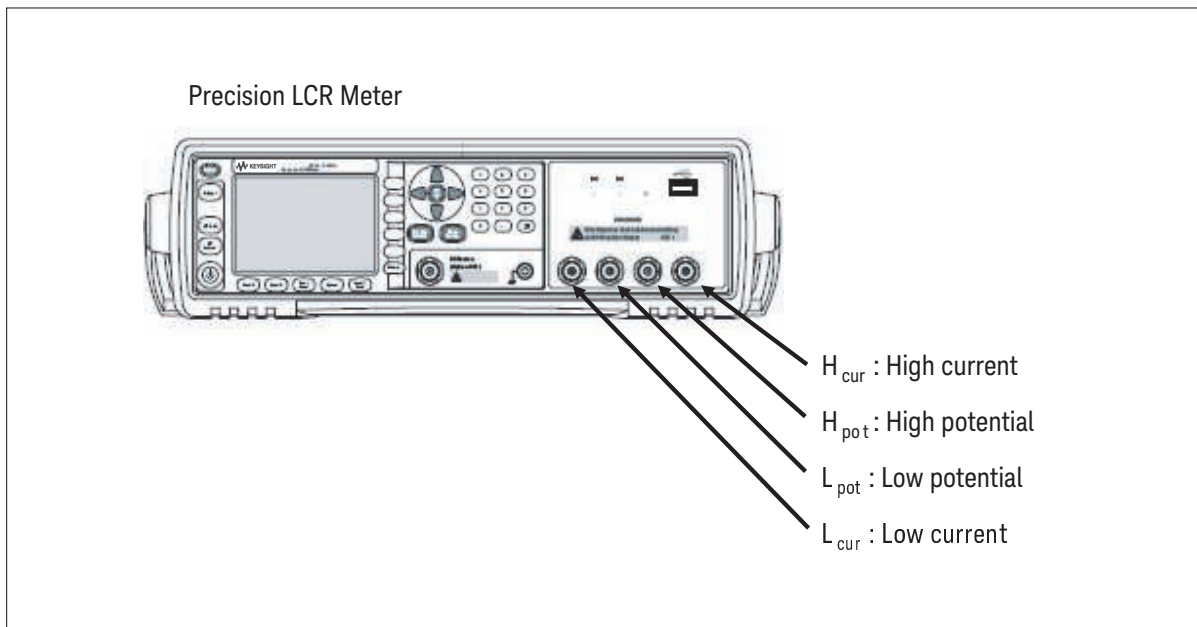


Figure 3-1. Measurement terminals of auto balancing bridge instrument

3.1.1 Two-terminal configuration

The two-terminal (2T) configuration is the simplest method of connecting a DUT but contains many error sources. Lead inductances (L_L), lead resistances (R_L), and stray capacitance (C_0) between two leads are added to the measurement result (see Figure 3-2.) Contact resistances (R) between the test fixture's electrodes and the DUT are also added to measured impedance. Because of the existence of these error sources, the typical impedance measurement range (without doing compensation) is limited to 100 Ω to 10 k Ω .

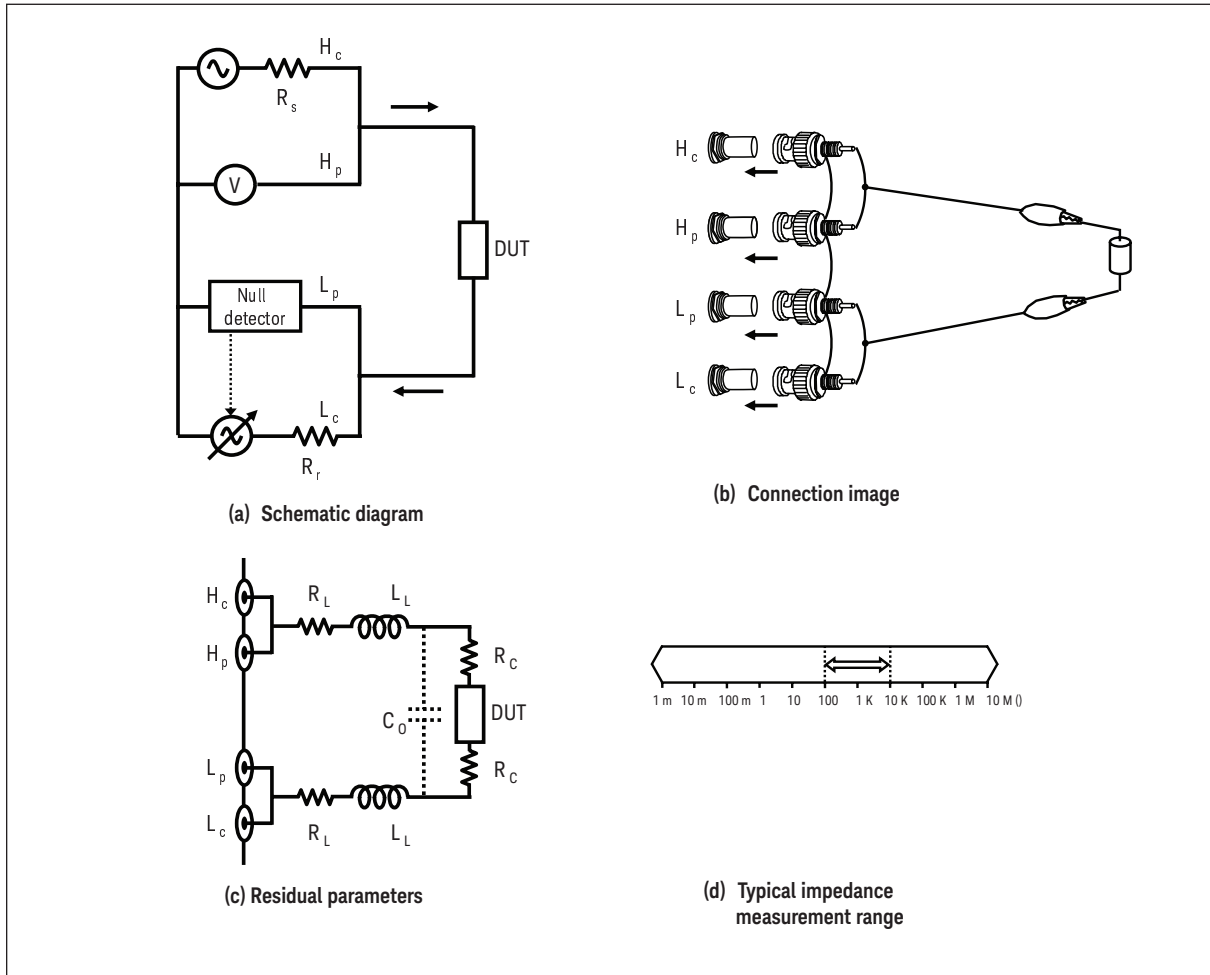


Figure 3-2. Two-terminal (2T) configuration

3.1.2 Three-terminal configuration

The three-terminal (3T) configuration employs coaxial cables to reduce the effects of stray capacitance. The outer shielding conductors of the coaxial cables are connected to the guard terminal. Measurement accuracy is improved on the higher impedance measurement range but not on the lower impedance measurement range, because lead impedances (ωL_L and R_L) and contact resistances (R_C) still remain (see Figure 3-3.) The typical impedance range will be extended above 10 k Ω . If the two outer conductors are connected to each other at the ends of the cables as shown in Figure 3-4, the accuracy for the lower impedance measurement is improved a little. This configuration is called the shielded 2T configuration.

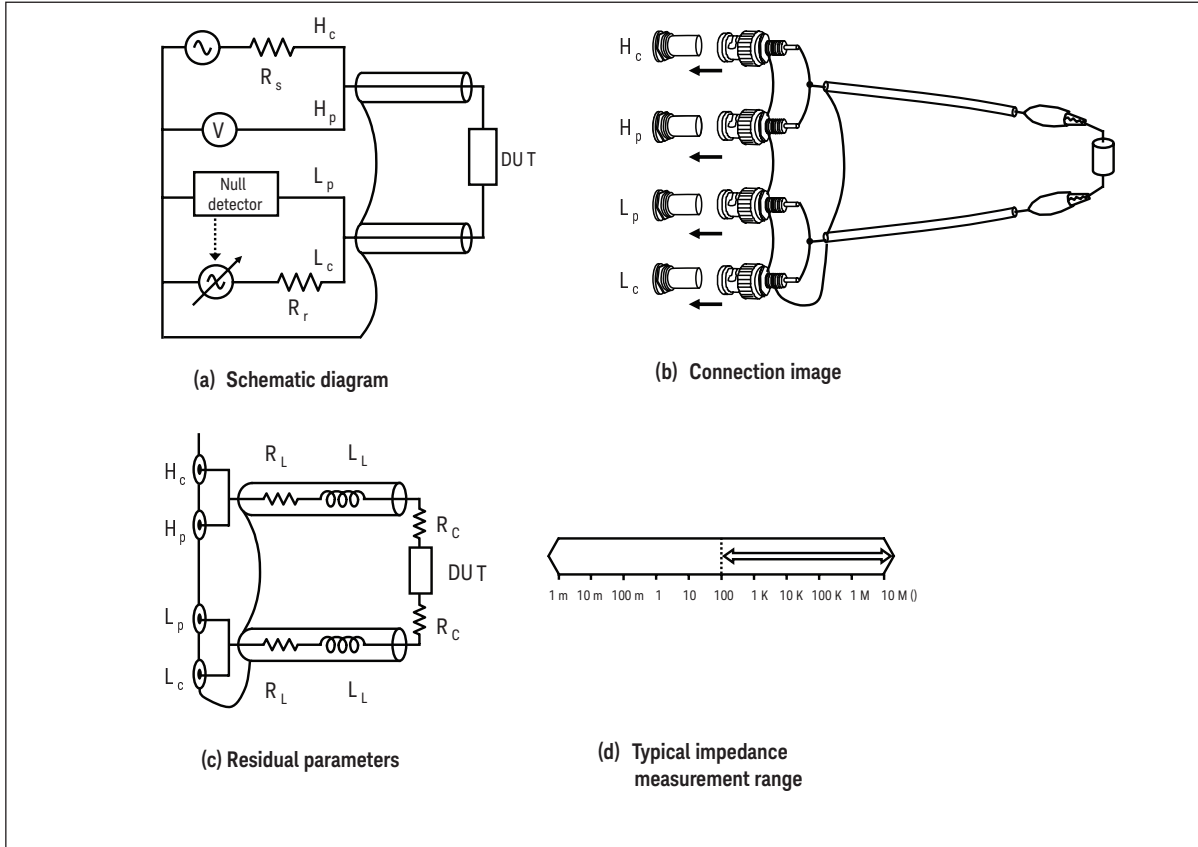


Figure 3-3. Three-terminal (3T) configuration

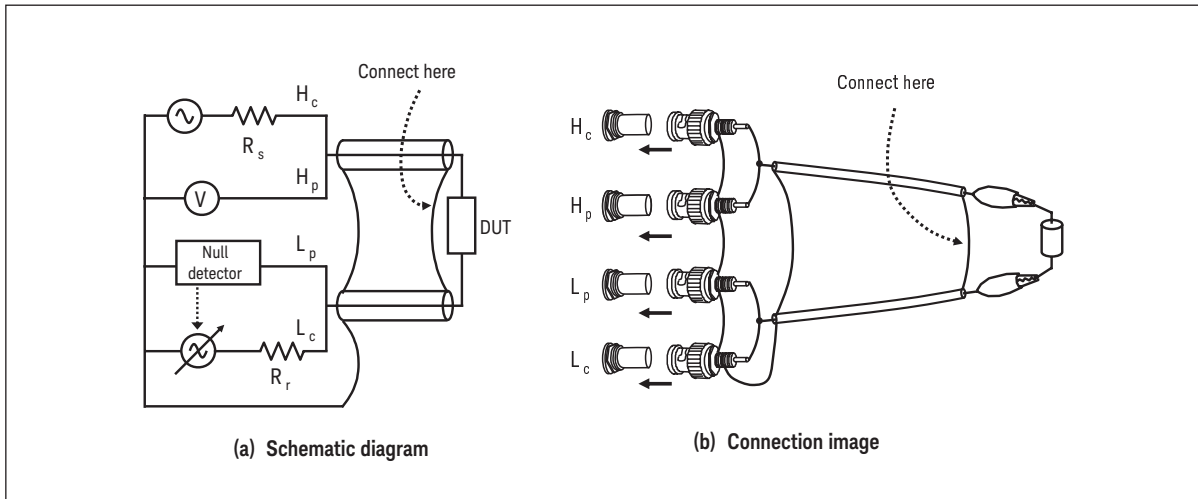


Figure 3-4. Shielded two-terminal (2T) configuration

3.1.3 Four-terminal configuration

The four-terminal (4T) configuration can reduce the effects of lead impedances (ωL_L and R_L) and contact resistances (R_c) because the signal current path and the voltage sensing leads are independent, as shown in Figures 3-5 (a) and (b). The voltage sensing leads do not detect the voltage drop caused by the R_L , L_L , and R_c on the current leads. The impedances on the voltage sensing leads do not affect measurement because signal current scarcely flows through these leads. Measurement errors due to the lead impedances and contact resistances are thereby eliminated. Accuracy for the lower impedance measurement range is thus improved typically down to 10 m Ω . Measurement accuracy on the higher impedance range is not improved because the stray capacitances between the leads still remain. The 4T configuration is also called Kelvin connection configuration.

When the DUT's impedance is below 10 m Ω , large signal current flows through the current leads, generating external magnetic fields around the leads. The magnetic fields induce error voltages in the adjacent voltage sensing leads. The effect of mutual coupling (M) between the current and voltage leads is illustrated in Figure 3-5 (e). The induced error voltages in the voltage sensing leads cause a measurement error in very low impedance measurements.

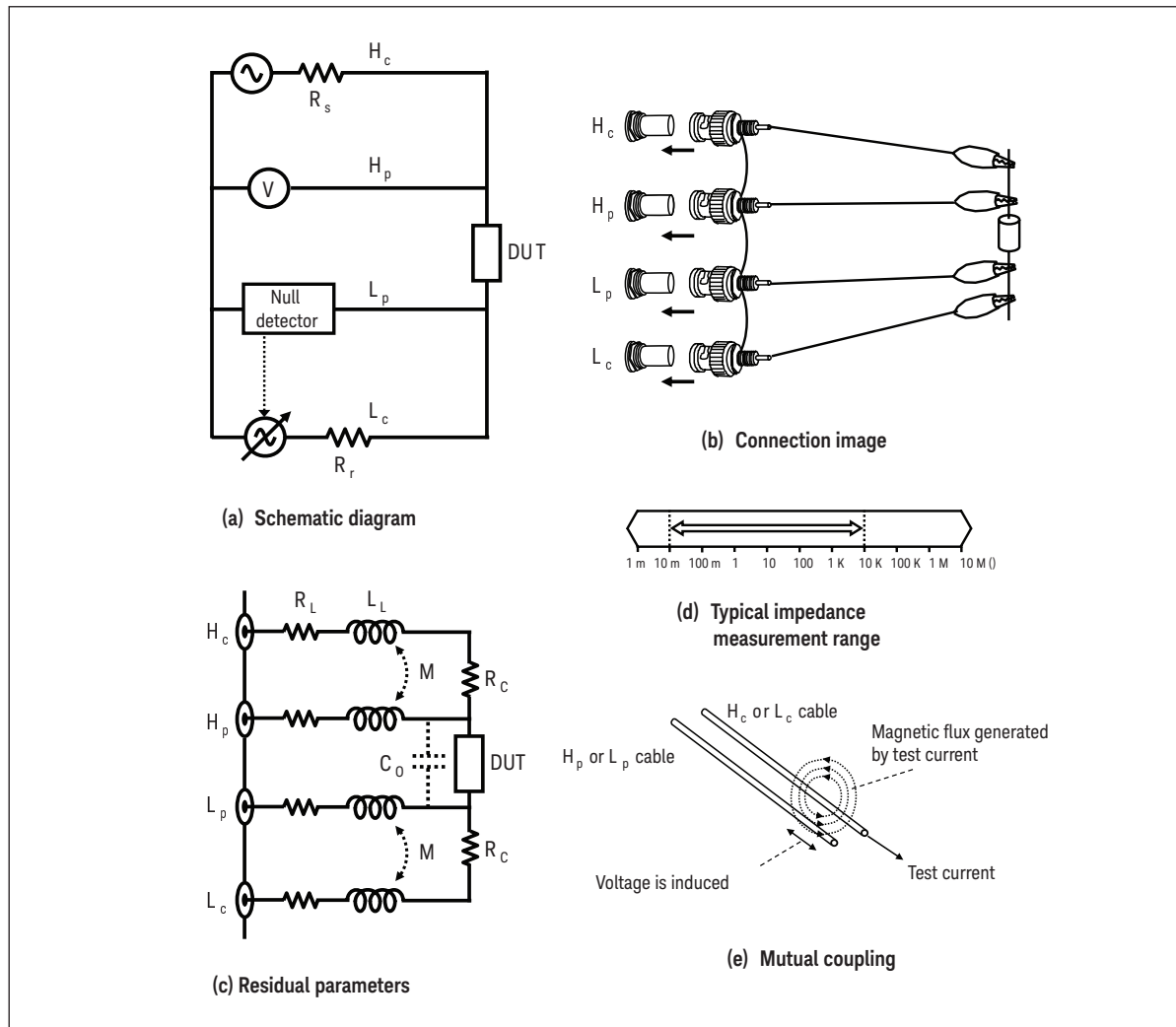


Figure 3-5. Four-terminal (4T) configuration

3.1.4 Five-terminal configuration

The five-terminal (5T) configuration is a combination of the three-terminal (3T) and four-terminal (4T) configurations. It is equipped with four coaxial cables and all of the outer shielding conductors of the four cables are connected to the guard terminal (see Figures 3-6 (a) and (b).) This configuration has a wide measurement range from 10 mΩ to 10 MΩ, but the mutual coupling problem still remains. If the outer conductors are connected to each other at the ends of the cables, as shown in Figure 3-7, the accuracy for the lower impedance measurement is improved a little. This configuration is called the shielded 4T configuration.

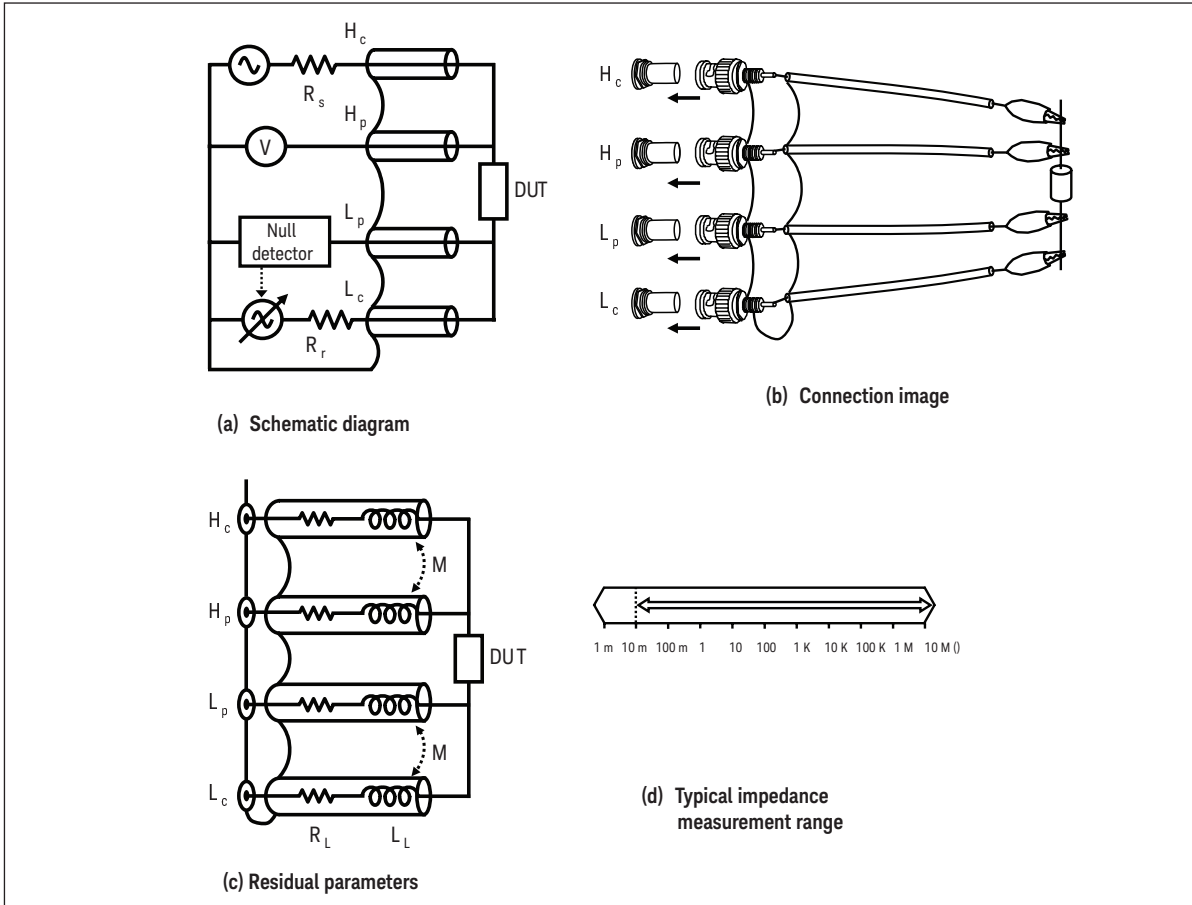


Figure 3-6. Five-terminal (5T) configuration

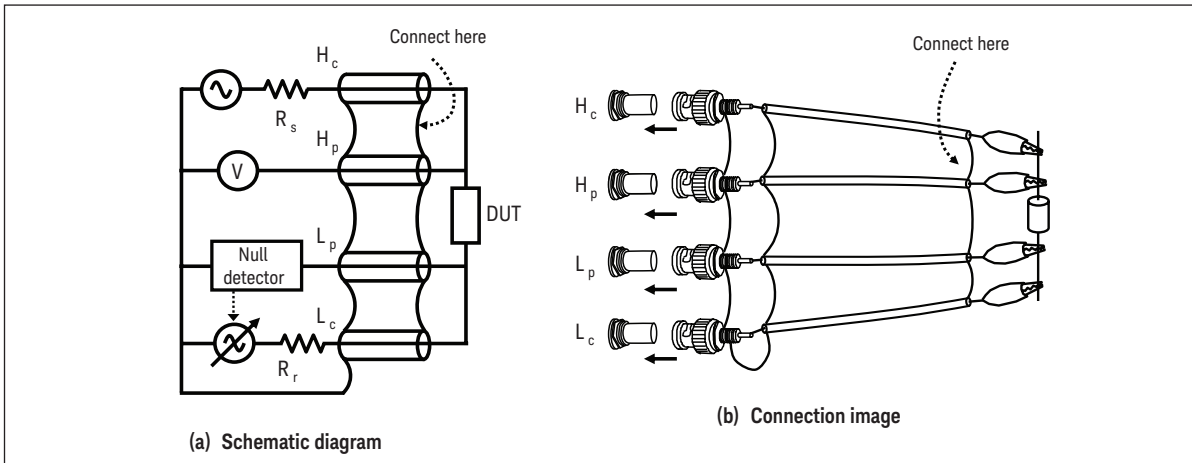


Figure 3-7. Shielded four-terminal (4T) configuration

3.1.5 Four-terminal pair configuration

The four-terminal pair (4TP) configuration solves the effects of mutual coupling between the leads by employing the following techniques either 1) and/or 2).

- 1) The outer shield conductors work as the return path for the test signal current (they are not grounded). The magnetic fields produced by the inner and outer currents cancel each other out because of the opposite directions and same amount of current flow. Hence there is little inductive magnetic field, test leads do not contribute to additional errors due to self or mutual inductance between the individual leads (Fig 3-8. (e))
- 2) A vector voltmeter measures the differential voltage between the inner and outer conductors. The differential measurement method can minimize the influence of the mutual inductance. (Fig 3-8. (a))

As a result, the mutual coupling problem is eliminated. The 4TP configuration can improve the impedance measurement range to below 1 mW. The measurement range achieved by this configuration depends on how well the 4TP configuration is strictly adhered to up to the connection point of the DUT.

Note: If the shielding conductors of the coaxial test cables are not interconnected properly at the ends of the cables, the 4TP configuration will not work effectively and, as a result, the measurement range will be limited, or in some cases, measurements cannot be made.

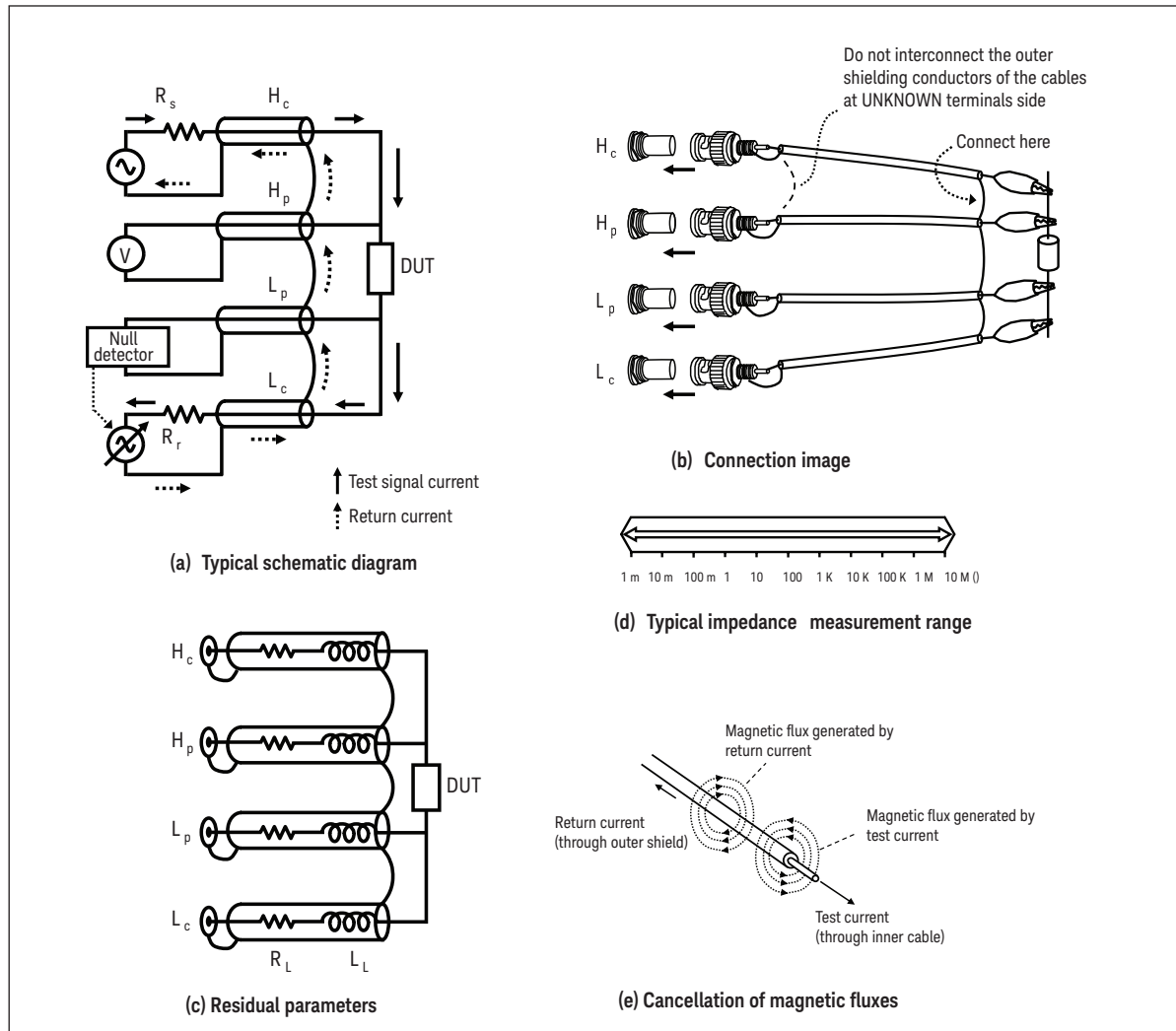


Figure 3-8. Four-terminal pair (4TP) configuration

3.2 Test fixtures

The test fixture plays an important role in impedance measurement both mechanically and electrically. The quality of the fixture determines the limit of the total measurement accuracy. This section discusses how to choose or fabricate a test fixture for use with auto-balancing bridge instruments.

3.2.1 Keysight-supplied test fixtures

Keysight Technologies supplies various types of test fixtures depending on the type of device being tested. To choose the most suitable test fixture for the DUT, consider not only the physical layout of the contacts but also the usable frequency range, residual parameters (usable impedance range), and the allowable DC voltage that can be applied. The contact terminals of the test fixtures (DUT connection) can be either 2T or 4T which are respectively suited to different applications. The DUT connection configuration and suitable application of Keysight's test fixtures are summarized in Table 3-1. The advantages and disadvantages of 2T and 4T test fixtures are detailed in Appendix A.

Note: The meaning of "DUT connection configuration" in this paragraph differs from that of the terminal configuration in Section 3.1. While the terminal configuration mainly refers to the cabling methods, the DUT connection configuration describes the particular configuration of test fixture's contact terminals. The test fixtures are classified into the groups of 2T and 4T fixtures by the DUT connection configuration as shown in Table 3-1.

Table 3-1. DUT connection configurations of Keysight test fixtures and their characteristics

DUT connection configuration	Applicable device type	Keysight test fixture	Basic characteristics	Suitable applications
2-terminal	Leaded device	16047D	– Measurement is susceptible to the effect of residual impedance and contact resistance	Impedance: Middle and high Frequency: High
		16047E		
		16065A		
		42842A/B/C		
	SMD (Surface mounted device)	16034E 16034G 16034H 16334A	– Usable frequency limit is high – Additional error at high frequencies is smaller than in 4-terminal connection	
In-circuit device	16451B 16452A 42941A			
4-terminal	Leaded device	16047A 16089A/B/C/D/E	– Measurement is less affected by residual impedance and contact resistance (at relatively low frequencies) – Usable frequency limit is low – Additional error at high frequencies is greater than in 2-terminal connection	Impedance: Low and middle Frequency: Low
		SMD (Surface mounted device)		

3.2.2 User-fabricated test fixtures

If the DUT is not applicable to Keysight-supplied test fixtures, create an application-specific test fixture. Key points to consider when fabricating a test fixture are:

- (1) **Residuals must be minimized.** To minimize the residuals, the 4TP configuration should be maintained as close as possible to the DUT. Also, proper guarding techniques will eliminate the effects of stray capacitance. For details, refer to “Practical guarding techniques” in Section 3.4.
- (2) **Contact resistance must be minimized.** Contact resistance will cause additional error. In the case of the 2T configuration, it directly affects the measurement result. The contact electrodes should hold the DUT firmly and should always be clean. Use a corrosion-free material for the electrodes.
- (3) **Contacts must be able to be opened and shorted.** Open/short compensation can easily reduce the effects of the test fixture's residuals. To perform an open measurement, the contact electrodes should be located the same distance apart as when the DUT is connected. For the short measurement, a lossless (low impedance) conductor should be connected between the electrodes, or the contact electrodes should be directly interconnected. If the 4T configuration is kept to the electrodes, make the connections of current and potential terminals, and then make an open or short as shown in Figure 3-9.

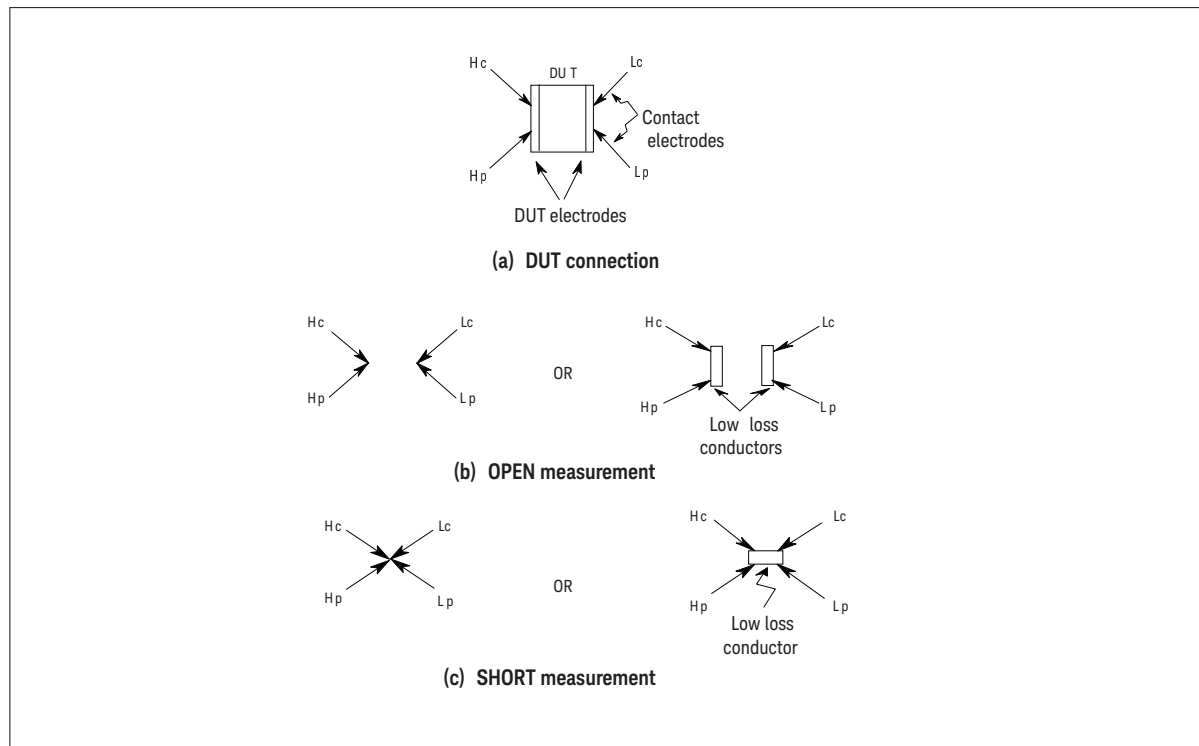


Figure 3-9. User-fabricated test fixture open/short methods

3.2.3 User test fixture example

Figure 3-10 shows an example of a user-fabricated test fixture. It is equipped with alligator clips as the contact electrodes for flexibility in making a connection to DUTs. Also, this test fixture can be connected directly to 4TP instruments.

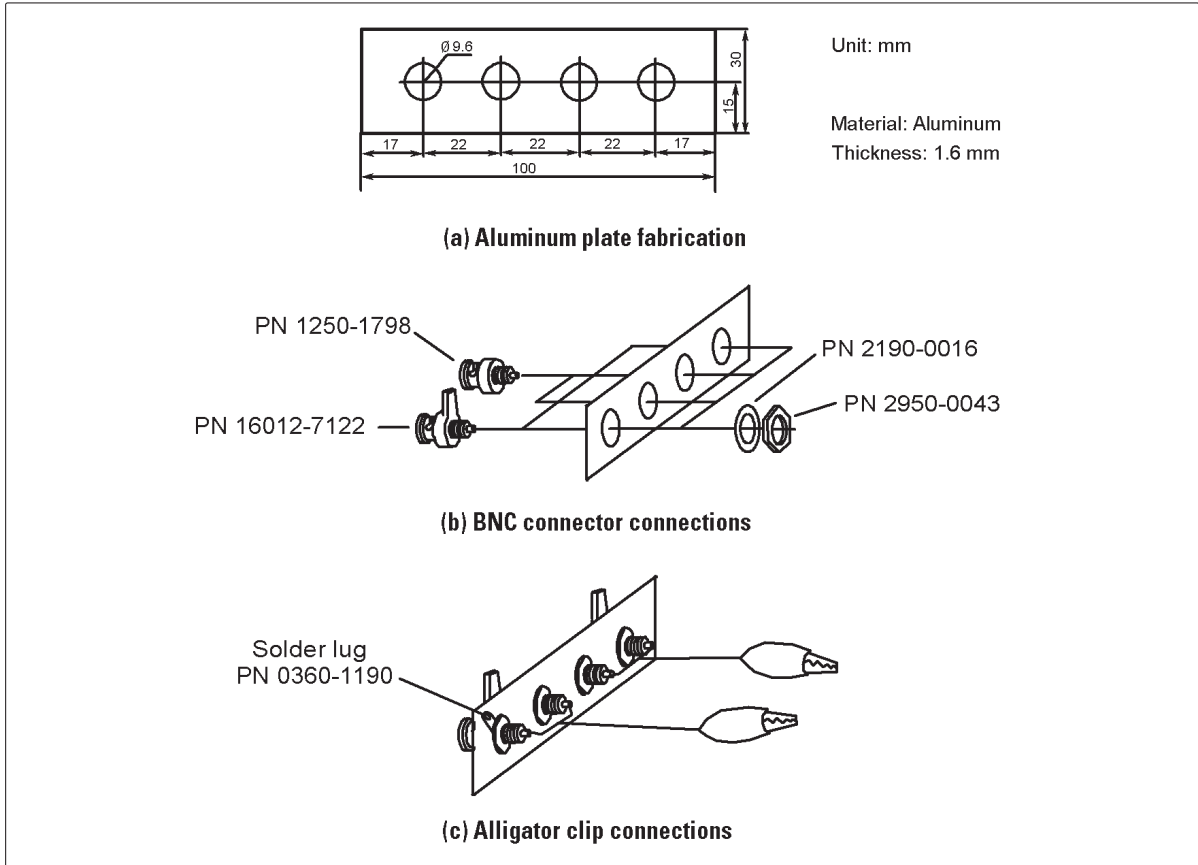


Figure 3-10. Example of fixture fabrication

3.3 Test cables

When the DUT is tested apart from the instrument, it is necessary to extend the test ports (UNKNOWN terminals) using cables. If the cables are extended without regard to their length, it will cause not only a measurement error, but will also result in bridge unbalance making measurement impossible. This section provides a guideline for choosing or fabricating test cables.

3.3.1 Keysight-supplied test cables

Keysight Technologies supplies 1, 2, and 4 m cables as listed in Table 3-2. The Keysight 16048A and 16048E test leads are manufactured using the same cable material. The Keysight 16048G and 16048H test leads employ a high-quality cable to insure low-loss transmission characteristics that specifically match the 4294A. The cable length and the usable frequency range must be considered when selecting a test cable. Keysight's instruments can minimize additional measurement errors because the characteristic of Keysight's test cables are known. Though the cable compensation function is effective for Keysight-supplied test cables, the measurement inaccuracy will increase according to the cable length and the measurement frequency.

Table 3-2. Keysight-supplied test cable

Test cable	Cable length	Maximum frequency	Connector type	Applicable instruments
16048A	1 m	30 MHz	BNC	4263B, 4268A, 4284A*, 4285A,
16048-65000			SMC	4288A, E4980A, E4981A
16048D	2 m	30 MHz	BNC	4263B, 4268A, 4284A*, 4285A,
				4288A, E4980A, E4981A
16048E	4 m	2 MHz		4263B, 4284A, E4980A
16048G	1 m	110 MHz		4294A
16048H	2 m	110 MHz		4294A

* Note: The 4284A is obsolete product.

3.3.2 User-fabricated test cables

Using cables other than those supplied by Keysight is not recommended. The cable compensation function of the instrument may not work properly in non-Keysight cables. If there is an unavoidable need to use non-Keysight cables, then employ the cable equivalent to Keysight test cables. The Keysight part number of the cable used for frequencies below 30 MHz is 8121-1218 (not applicable to the 4294A.) Electrical specifications for these cables are provided in Figure 3-11. Do not use test cables other than Keysight-supplied cables for higher frequencies.

To extend the cables using the 4TP configuration, the cable length should be adapted to the instrument's cable length correction function (1 m, 2 m, or other selectable cable length.) An error in the cable length will cause additional measurement error. A detailed discussion on the cable extension is provided in Section 3.3.3 and in Section 4.

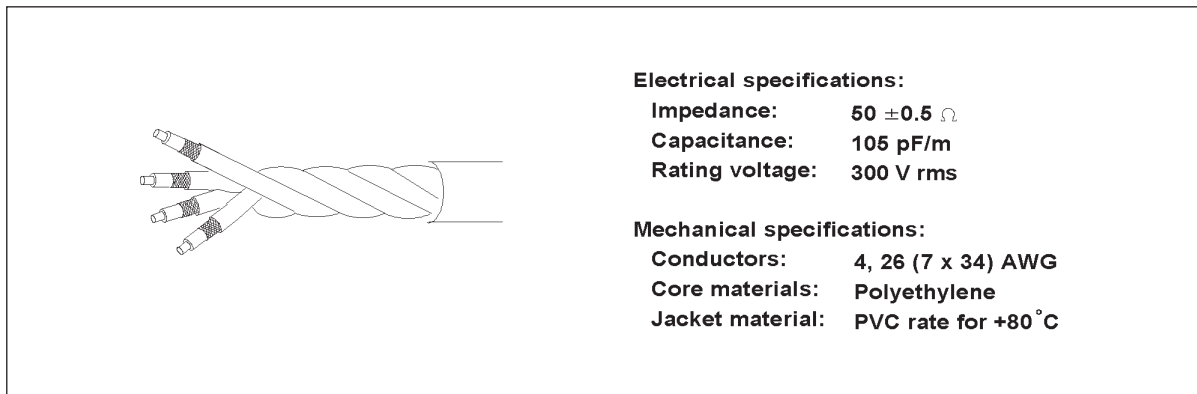


Figure 3-11. Specifications of recommended cable (Keysight part number 8121-1218)

3.3.3 Test cable extension

If the required test cable is longer than 1, 2, or 4 m, it is possible to extend the Keysight-supplied test cable by using the following techniques.

4TP-4TP extension

As shown in Figure 3-12 (a), all the outer shielding conductors are interconnected at far ends of the extension cables. Actual connection can be made using four BNC (f) to BNC (f) adapters (Keysight part number 1250-0080 x 4) as illustrated in Figure 3-12 (b). It is recommended that the BNC adapters be held in place with an insulation plate to keep the adapters isolated (so as to not break the 4TP configuration.)

Note: If a conductive plate is used to hold the BNC adapters (without inserting insulators between the BNC adapters and the plate), the 4TP configuration is terminated at the plate and the return current does not flow through the extension cables.

Although this technique can provide the best accuracy, especially for low impedance measurement, the extension length is limited by the measurement frequency. This is because the total length of the series cables must be sufficiently shorter than the wavelength of the measurement signal. The following equation gives a guideline for determining typical cable length limitation:

$$F \text{ (MHz)} \times L \text{ (m)} \leq 15$$

F: Measurement frequency (MHz)
L: Cable length (m)

When the cable length is one meter, the maximum frequency limit will be approximately 15 MHz. If the cable length or frequency exceeds this limit, the auto-balancing bridge may not balance. For higher frequency measurements or longer extension, the shielded 2T extension technique, which is described next, should be used.

Note: The 4294A helps prevent the cable length limitation by terminating the test ports with the same impedance as the characteristic impedance of specified test cables at high frequencies. However, the practical cable length limit due to increase in measurement error still exists.

Note: Additional measurement error and the compensation regarding the 4TP-4TP extension are described in Section 4.5.

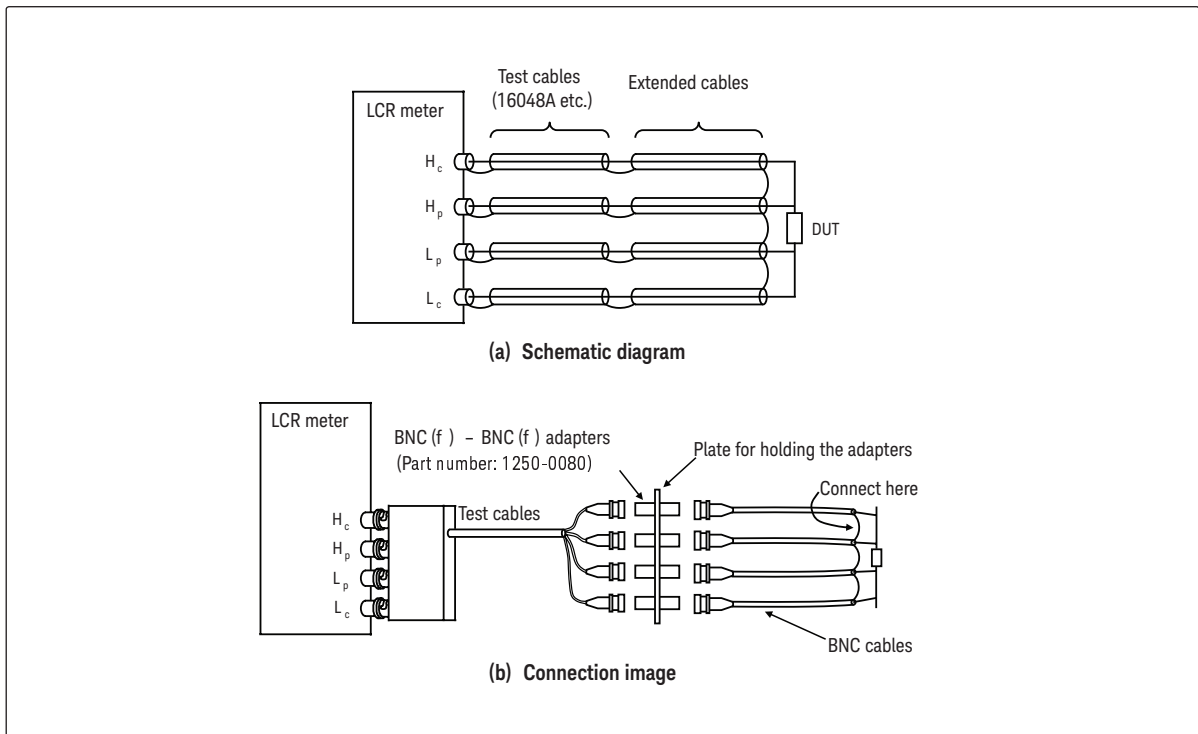


Figure 3-12. 4TP-4TP extension

Shielded 2T extension

As shown in Figure 3-13, the 4TP configuration is terminated and the extension cables configure a modified 3T (shielded 2T). The two outer shielding conductors are connected together at each end of the cable. This decreases the magnetic field induced by the inner conductors. This technique is used in the higher frequency region, up to 15 MHz. The residual impedance of the cables will be directly added to the measurement result, but can be an insignificant error source if the DUT's impedance is greater than the impedance due to the residuals. For the actual connection, a connector plate (Keysight part number 16032-60001) supplied with Keysight test cables can be used as shown in Figure 3-13.

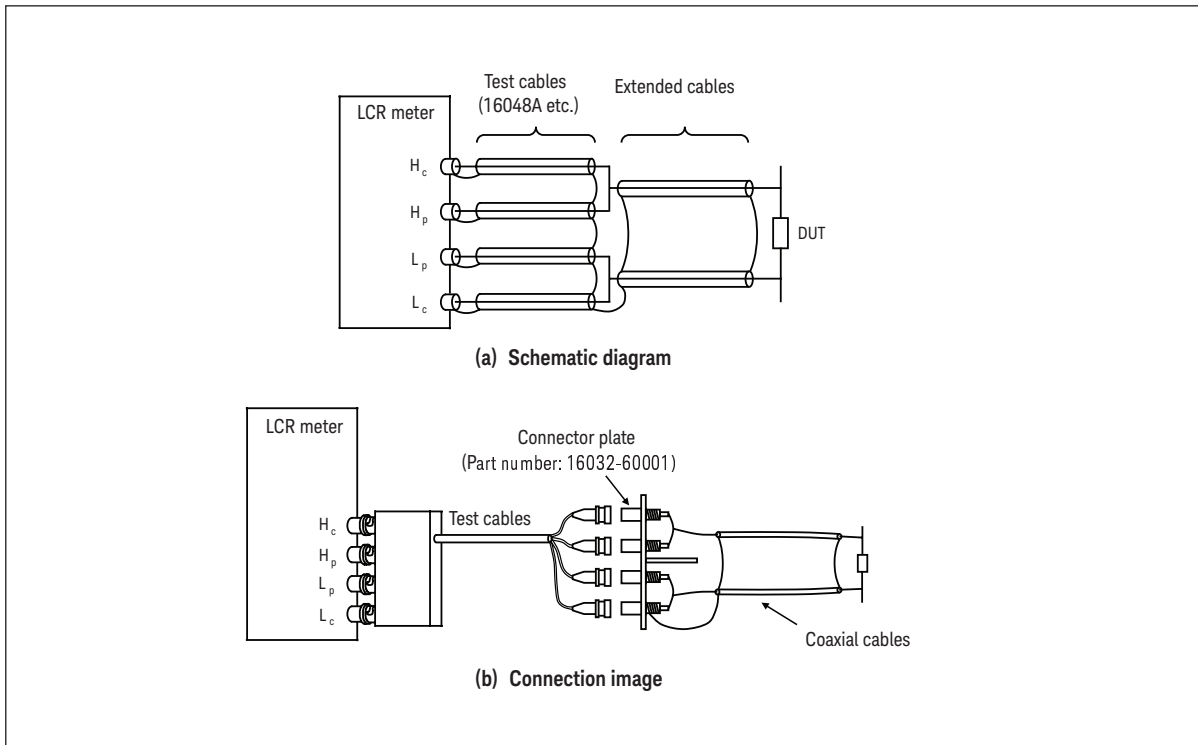


Figure 3-13. Shielded 2T extension

Shielded 4T extension

The outer shielding conductors of coaxial cables are interconnected at each end of the cables, as shown in Figure 3-14. The shielded 4T extension can be used for accurate low-impedance measurements. However, when applied to high-frequency measurements (typically above 3 MHz), this extension method produces greater measurement errors than the shielded 2T extension because the error sources at high frequencies are complicated. The length of the shielded 4T extension in the high frequency region should be made as short as possible.

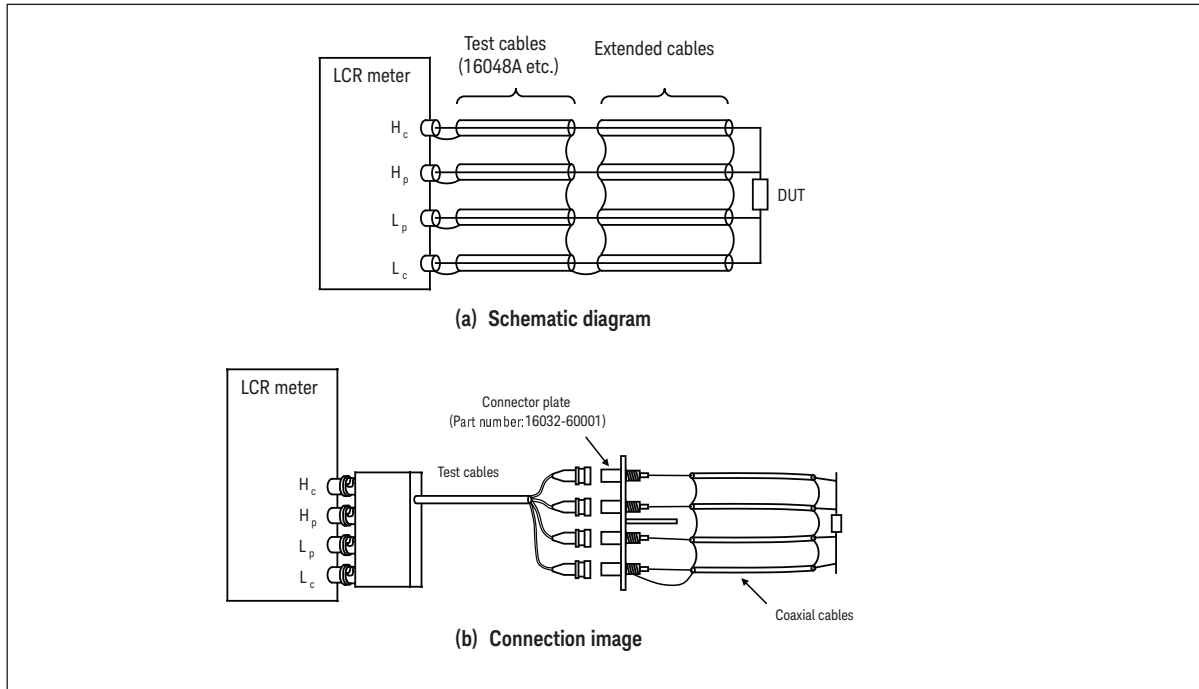


Figure 3-14. Shielded 4T extension

Table 3-3 summarizes the extension techniques and their applicable impedance/frequency range.

Table 3-3. Summary of cable extension

Measured impedance	Typical measurement frequency	
	100 kHz and below	Above 100 kHz
Low (Typically 100 Ω and below)		4TP - 4TP
Medium (Typically 100 Ω to 100 kΩ)	4TP - 4TP	4TP - Shielded 4T
High (Typically 100 kΩ and above)		4TP - Shielded 2T

3.4 Practical guarding techniques

3.4.1 Measurement error due to stray capacitances

When the DUT is located near a conductor (for example, a metallic desktop) and a measurement signal is applied to the DUT, a voltage difference will appear between the DUT and the nearby conductor. This creates stray capacitances and allows the measurement signal to leak towards the conductor as shown in Figure 3-15 (a). Unshielded portions of test leads also have stray capacitances to the conductor.

Signal leakage through the stray capacitance on the High side of the DUT will bypass the DUT by flowing through the conductor and the stray capacitance on the Low side. The ammeter (I-V converter) on the L_c side measures the sum of the DUT current and the additional leakage current caused by the stray capacitances. Thus, the effect of stray capacitances results in measurement error. The stray capacitances produce greater measurement error for higher impedance of DUT and at higher measurement frequencies.

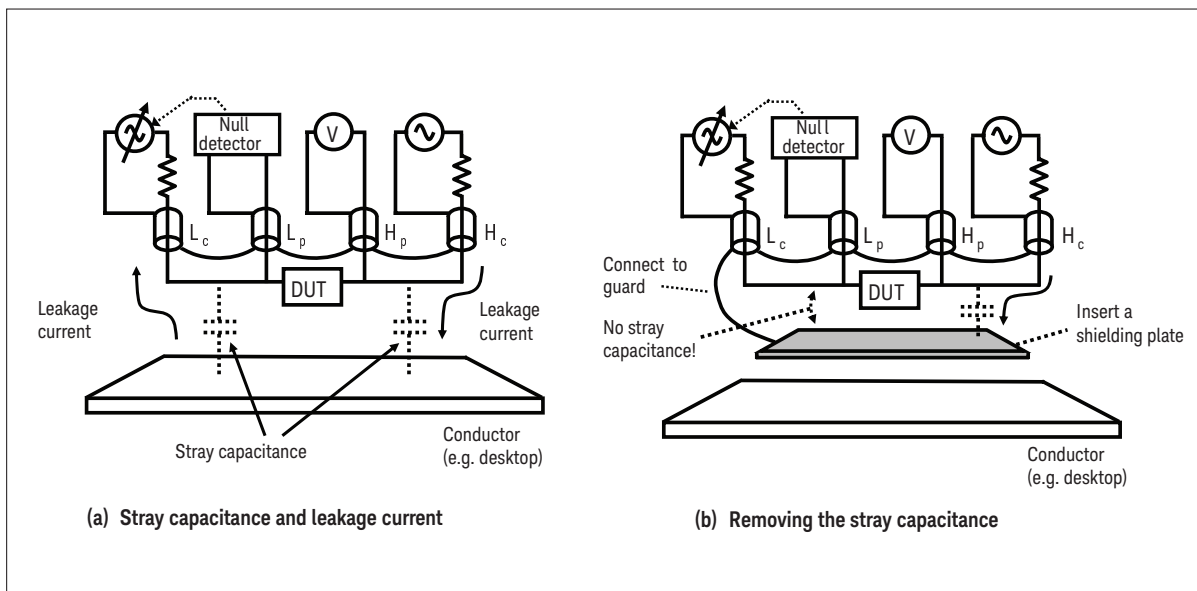


Figure 3-15. Guarding technique (1)

3.4.2 Guarding technique to remove stray capacitances

By inserting a shielding plate between the DUT and the conductor, and by connecting it to the guard terminal of the instrument as shown in Figure 3-15 (b), the leakage current flow through the stray capacitances can be eliminated. Since the Low side of the DUT has a potential of zero volts (virtual ground) equal to the guard potential, the voltage difference that yields the stray capacitance on the Low side is extinguished. Basically, the guard terminal is the outer shielding conductor of the test cables.

Note: If the conductor yielding the stray capacitances is isolated from the ground and is free of noise, it may be directly connected to the guard terminal without using the additional shielding plate. On the contrary, if the conductor has a noise potential, this method should be avoided because noise current flows into the outer shielding conductor of test cables and may disturb measurements.

When a stray capacitance in parallel with the DUT is present between High and Low terminals, as shown in Figure 3-16 (a), it can be removed by inserting a shielding plate between the High and Low terminals and by connecting the plate to the guard terminal (as shown in Figure 3-16 (b).)

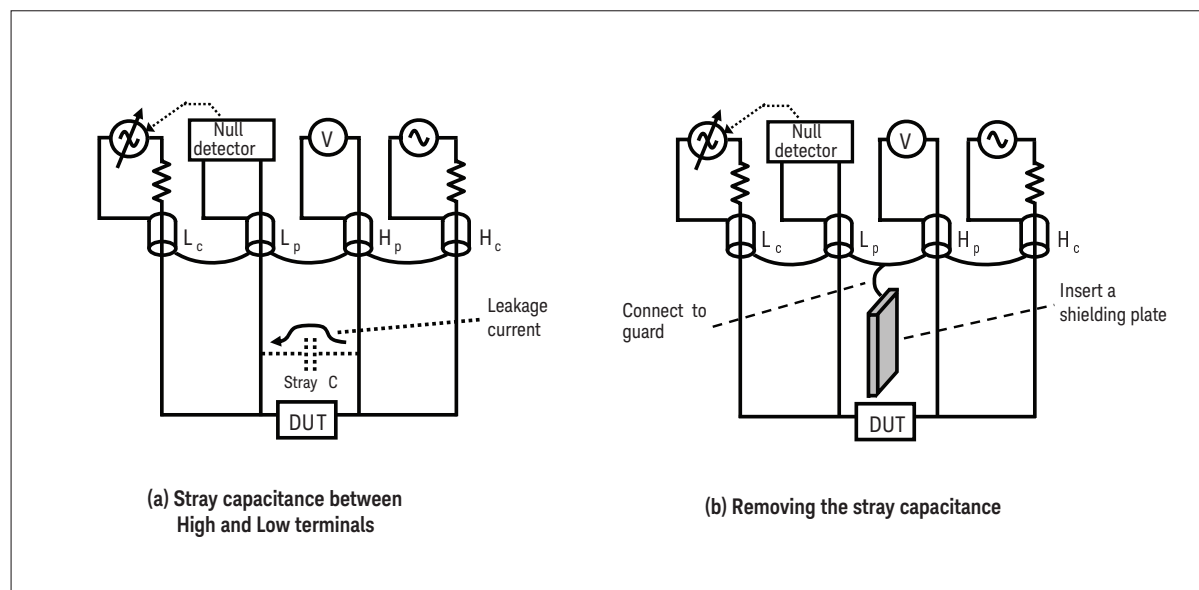


Figure 3-16. Guarding technique (2)

3.5 Terminal configuration in RF region

RF impedance measuring instruments have a precision coaxial test port, which is actually a 2T configuration in principle. The center conductor of the coaxial test port connector is active (High side) terminal and the outer conductor is grounded Low side terminal, as shown in Figure 3-17. To measure the DUT, only the simplest 2T connection configuration can be used. Residual inductance, residual resistance, stray capacitance, and stray conductance of the test fixture will add to measurement results (before compensation.) Whether using the RF I-V method or network analysis, RF impedance measurement has lower accuracy as the measured impedance differs greater from 50 Ω .

Instrument inaccuracy, rather than the error factors in the 2T test fixture, primarily limits the measurement range. The effect of residuals increases with frequency and narrows the measurable impedance range in very high frequencies.

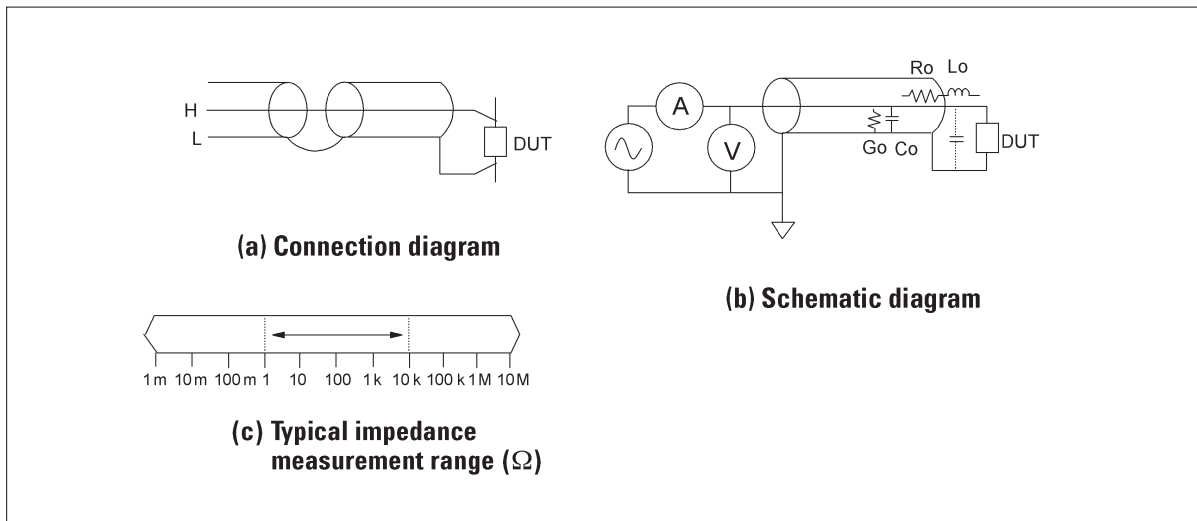


Figure 3-17. Coaxial test port circuit configuration

3.6 RF test fixtures

RF test fixtures are designed so that the lead length (electrical path length) between the DUT and the test port is made as short as possible to minimize residuals. At frequencies typically below 100 MHz, measurement error due to test fixture residuals is small compared to instrument error and is normally negligible after compensation is made. But, especially when measuring low or high impedance close to the residual parameter values, variance in the residuals of the test fixture will cause measurement repeatability problems. For example, when measuring a 1 nH inductor (a very low inductance), a slight variance of 0.1 nH in residual inductance will produce a 10 percent difference in the measured value. The variance in the residual, and resultant measurement instability, is dependent on the accurate positioning of the DUT on the test fixture terminals. For repeatable measurements, RF test fixtures should be able to precisely position the DUT across measurement terminals.

The test fixture residuals will have greater effects on measurements at higher frequencies (typically above 500 MHz) and will narrow the practical measurement range. Therefore, the usable frequency range of the test fixture is limited to the maximum frequency specified for each test fixture.

The measurement inaccuracy for the DUT is given by sum of the instrument's inaccuracy and the test-fixture induced errors. Because only the 2T measurement configuration is available, the compensation method is crucial for optimizing measurement accuracy. The measurement error sources and compensation techniques are discussed in Section 4.

Each test fixture has unique characteristics and different structures. Since not only the residuals but also the surrounding conditions of the DUT (such as ground plate, terminal layout, dielectric constant of insulator, etc.) influence the measured values of the DUTs, the same type of test fixture should be used to achieve good measurement correlation.

3.6.1 Keysight-supplied RF test fixtures

Keysight Technologies offers various types of RF test fixtures that meet the type of the DUT and required test frequency range. Consider measurable DUT size, electrode type, frequency, and bias condition to select a suitable test fixture.

There are two types of RF test fixtures: coaxial and non-coaxial test fixtures, which are different from each other in geometrical structures and electrical characteristics. As the non-coaxial test fixture has open-air measurement terminals as shown in Figure 3-18 (a), it features ease of connecting and disconnecting DUTs. The non-coaxial type is suitable for testing a large number of devices efficiently. Trading off the benefit of measurement efficiency, the measurement accuracy tends to be sacrificed at high frequencies because discontinuity (miss-match) in electrical characteristics exists between the coaxial connector part and the measurement terminals. The coaxial test fixture holds DUTs using a similar configuration to the coaxial terminations, as shown in Figure 3-18 (b). The DUT is connected across the center electrode and the outer conductor cap electrode of the test fixture. With $50\ \Omega$ characteristic impedance continuously maintained from test port to the DUT, the coaxial test fixture provides the best measurement accuracy and the best frequency response. As the diameter of its replaceable insulator can be selected to minimize the gap between the DUT and the insulator, the DUT can be positioned with a good repeatability across the test fixture's terminals independently of operator skill. The coaxial test fixture ensures less additional errors and much better measurement repeatability than the non-coaxial test fixtures.

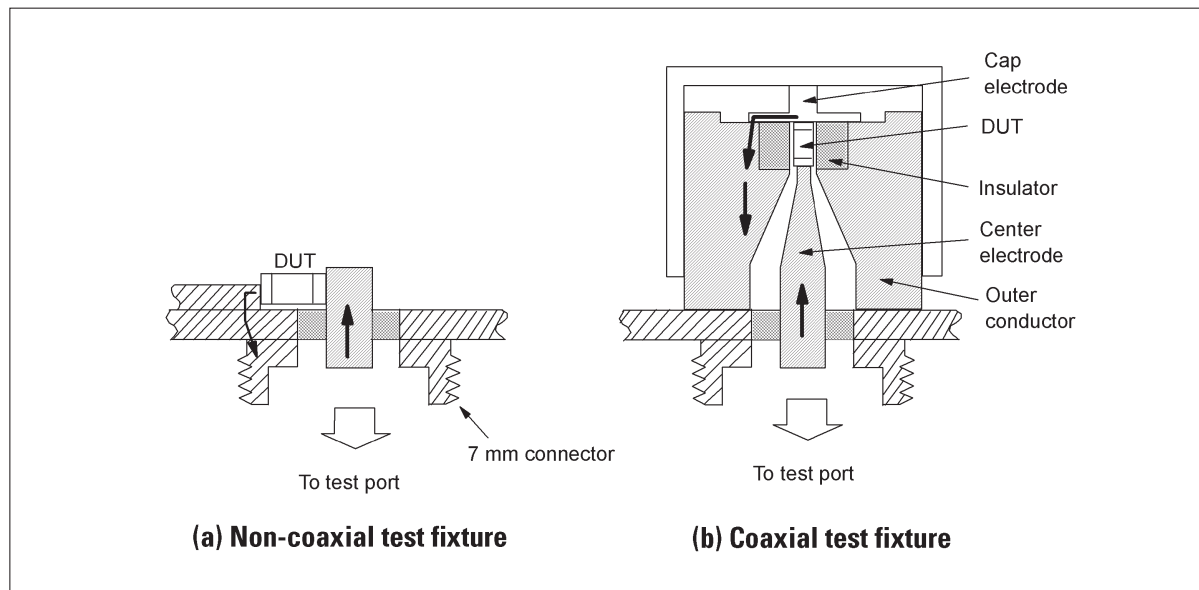


Figure 3-18. Types of RF impedance test fixtures

3.7 Test port extension in RF region

In RF measurements, connect the DUT closely to the test port to minimize additional measurement errors. When there is an unavoidable need for extending the test port, such as in-circuit testing of devices and on-wafer device measurement using a prober, make the length of test port extension as short as possible. If the instrument has a detachable test head, it is better for accuracy to place the test head near the DUT in order to minimize the test port extension length, and interconnect the test head and the instrument using coaxial cables. (Observe the limit of maximum interconnection cable length specified for the instrument.) Using a long test port extension will involve large residual impedance and admittance of the extension cable in the measurement results, and significantly deteriorate the accuracy even if calibration and compensation are completed.

Figure 3-19 shows an equivalent circuit model of the port extension. The inductance (L_o), resistance (R_o), capacitance (C_o), and conductance (G_o) represent the equivalent circuit parameter values of the extension cable. When the DUT's impedance (Z_x) is nearly $50\ \Omega$, the test signal is mostly fed to the DUT as the cable causes only a phase shift and (relatively small) propagation loss like a transmission line terminated with its characteristic impedance. However, most likely the DUTs have a different value from $50\ \Omega$. If the impedance of the DUT is greater than that of C_o , the test signal current mainly bypasses through C_o , flowing only a little through the DUT. Conversely, if the impedance of the DUT is lower than that of L_o and R_o , the test signal voltage decreases by a voltage drop across the cable and is applied only a little to the DUT. As a result, the cable residuals lead to measurement inaccuracy and instability, particularly, in high-impedance and low-impedance measurements. As illustrated in Figure 3-19, the L_o , R_o , C_o , and G_o not only get involved in the measurement results (before compensation), but also affect measurement sensitivity. Note that the measurable impedance range becomes narrow due to port extension even though the calibration and compensation have been performed appropriately.

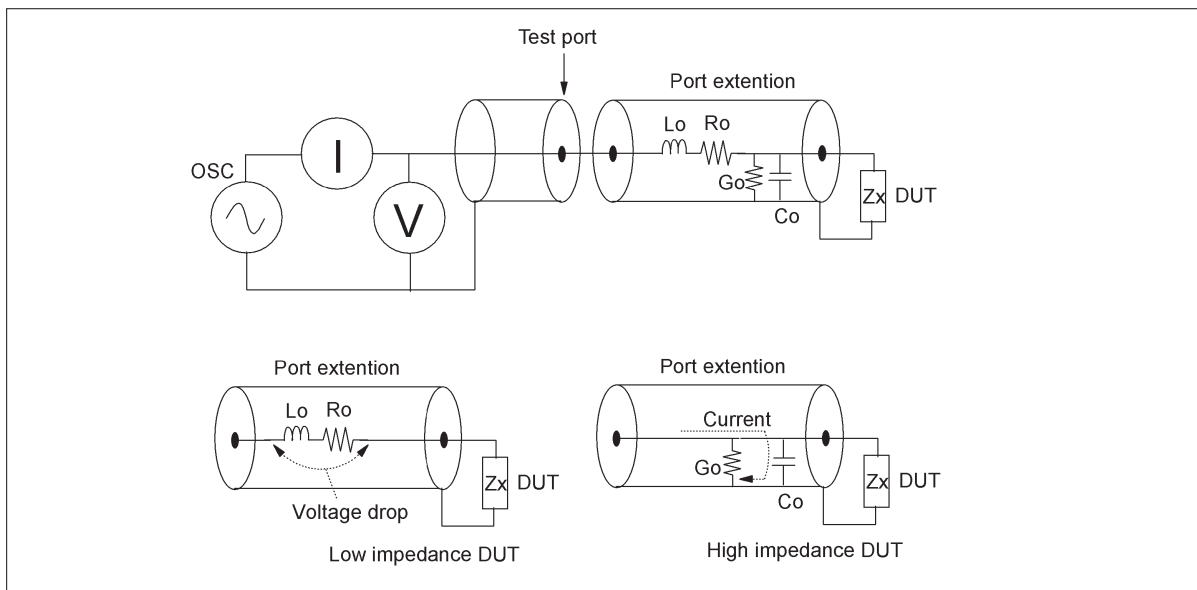


Figure 3-19. Calibration plane extension

In addition, electrical length of the extension cable will vary with environmental temperature, causing phase measurement instability. Using longer extension makes measurement results more susceptible to the influence of environmental temperature changes. Bending the cable will also cause variance in measured phase angle, deteriorating measurement repeatability. Accordingly, in any application the port extension should be minimized.

The RF I-V and network analysis instruments commonly employ an N-type or 7-mm type coaxial connector as the UNKNOWN terminal. Naturally, test port extension is made using a low-loss, electrically-stable coaxial transmission line (cable) with 50 Ω characteristic impedance. When choosing the cable, consideration should be given to temperature coefficients of propagation constants and rigidity to restrain the cable from easily bending. Figure 3-20 shows an example of the test fixture connected at the end of a 7 mm-7 mm connector cable. Calibration should be performed first at the end of the extension before connecting to the test fixture. Next, the electrical length and open/short compensations for the test fixture can be performed. (Alternatively, instead of the compensation, the open/short/load calibration may be performed with working-standards connected at the test fixture's measurement terminals. This method does not require the calibration at the end of the extension.) A detailed discussion on measurement error sources, calibration, and compensation is provided in Section 4.

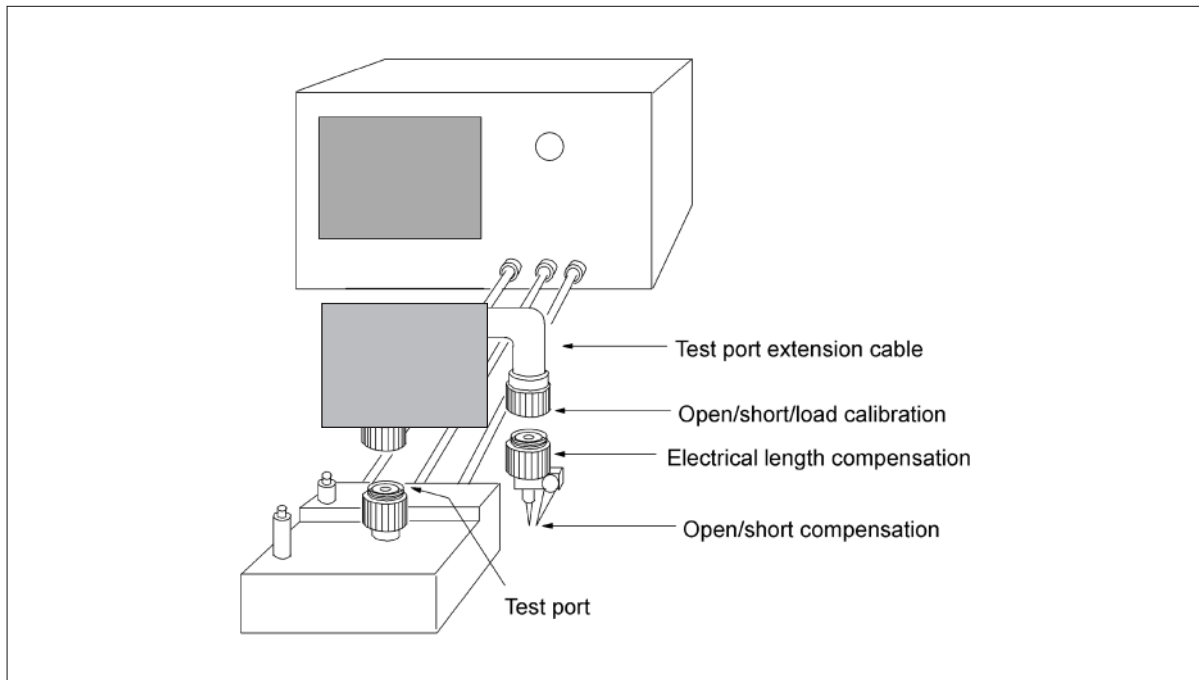


Figure 3-20. Practical calibration and compensation at extended test port

4.0 Measurement Error and Compensation

4.1 Measurement error

For real-world measurements, we have to assume that the measurement result always contains some error. Some typical error sources are:

- Instrument inaccuracies (including DC bias inaccuracy, test signal level inaccuracy, and impedance measurement inaccuracy)
- Residuals in the test fixture and cables
- Noise

The DUT's parasitics are not included in the above list because they are a part of the DUT. The parasitics are the cause of component dependency factors (described in Section 1.5) and dominate the real characteristics of components. The objective of component measurement is to accurately determine the real value of a component including parasitics. In order to know the real values of the DUTs, we need to minimize the measurement errors by using proper measurement techniques. In the listed error sources, the residuals in the test fixture and test cables can be compensated for if they are constant and stable.

4.2 Calibration

Calibration verifies instrument accuracy by comparing the instrument with "standard devices." To calibrate an instrument, standard devices are connected at the calibration plane and the instrument is adjusted (through computation/data storage) so that it measures within its specified accuracy. The calibration plane indicates the electrical reference plane at which the standard devices are connected and measured. Accordingly, calibration defines the calibration plane at which the specified measurement accuracy can be obtained.

The calibration plane of auto-balancing bridge instruments is at the UNKNOWN BNC connectors (see Figure 4-1.) When the cable length correction is performed, the calibration reference plane moves to the tip of the test cables. After an auto-balancing bridge instrument is shipped from the factory, calibration is usually required for maintenance and service purposes. To maintain the instrument within the specified accuracy, calibration should be performed periodically at the recommended calibration intervals (typically once a year.)

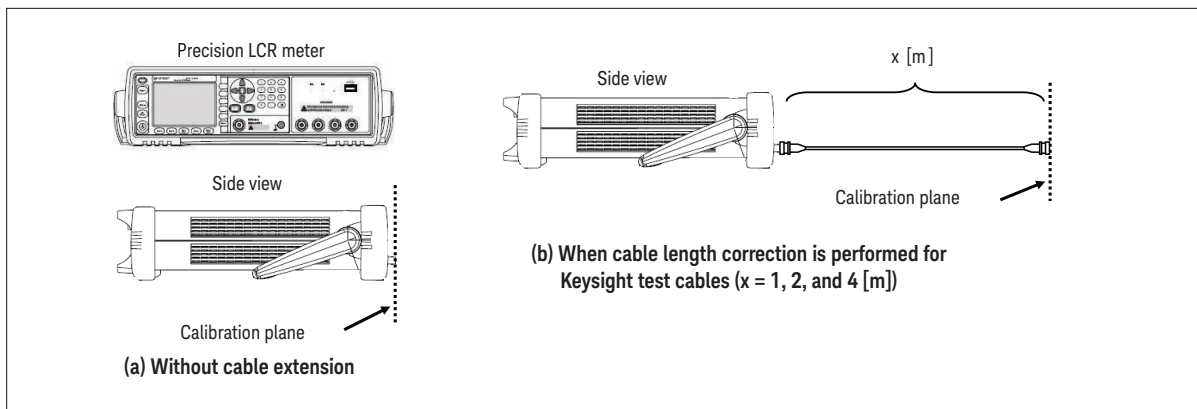


Figure 4-1. Calibration plane of auto-balancing bridge instruments

RF-IV instruments require calibration every time the instrument is powered on or every time the frequency setting is changed. This is because ambient temperature, humidity, frequency setting, etc. have a much greater influence on measurement accuracy than in low frequency impedance measurements. Calibration is performed using open, short, and load reference terminations (a low loss capacitor termination is also used as necessary) as described in Section 4.7.1. The calibration plane is at the test port or the tip of test port extension where the calibration reference terminations are connected (see Figure 4-2.)

Note: The calibration of the RF I-V instruments that should be performed prior to measurements eliminates impedance measurement errors under the desired measurement conditions. The RF I-V instruments also require periodic calibration at the recommended intervals for maintaining their overall operating performance within specifications.

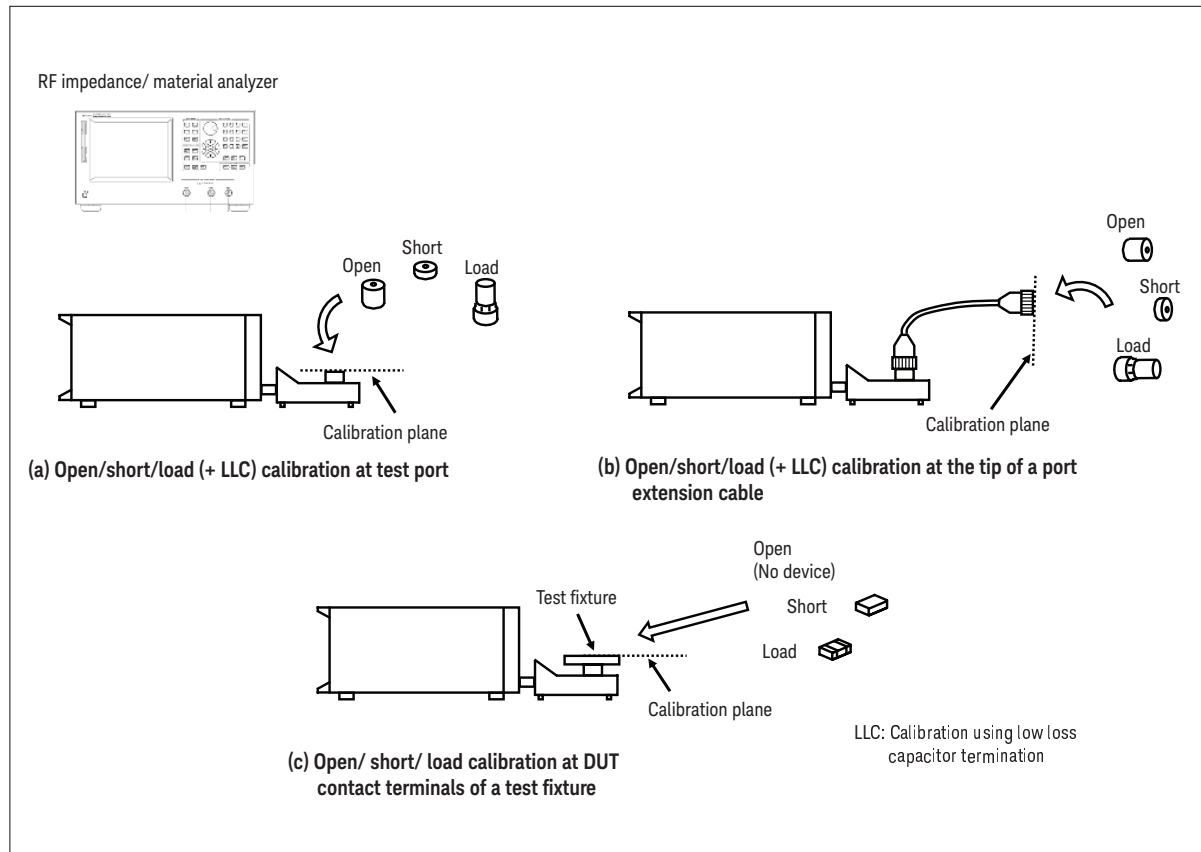


Figure 4-2. Calibration plane of RF-IV instruments

4.3 Compensation

Compensation is also called correction and reduces the effects of the error sources existing between the DUT and the instrument's calibration plane. Compensation, however, can not always completely remove the error. Thus, the measurement accuracy obtained after compensation is not as good as that obtained at the calibration plane. Compensation is not the same as calibration and can not replace calibration. Compensation data is obtained by measuring the test fixture residuals. The accuracy of compensation data depends on the calibration accuracy of the instrument, so compensation must be performed after calibration has been completed.

Compensation improves the effective measurement accuracy when a test fixture, test leads, or an additional measurement accessory (such as a component scanner) is used with the instrument. The following paragraphs describe three commonly used compensation techniques:

- Offset compensation
- Open/short compensation
- Open/short/load compensation

Note: The open/short/load compensation for the auto-balancing bridge instrument (described in Section 4.3.3) is not applied to RF-IV instruments because the compensation theory for the RF-IV method is different from that for the auto-balancing bridge method.

4.3.1 Offset compensation

When a measurement is affected by only a single component of the residuals, the effective value can be corrected by simply subtracting the error value from the measured value. For example, in the case of the low value capacitance measurement shown in Figure 4-3, the stray capacitance (C_o), paralleled with the DUT's capacitance (C_x) is significant to the measurement and can be removed by subtracting the stray capacitance value from the measured capacitance value (C_{xm}). The stray capacitance value is obtained with the measurement terminals left open (C_{om}).

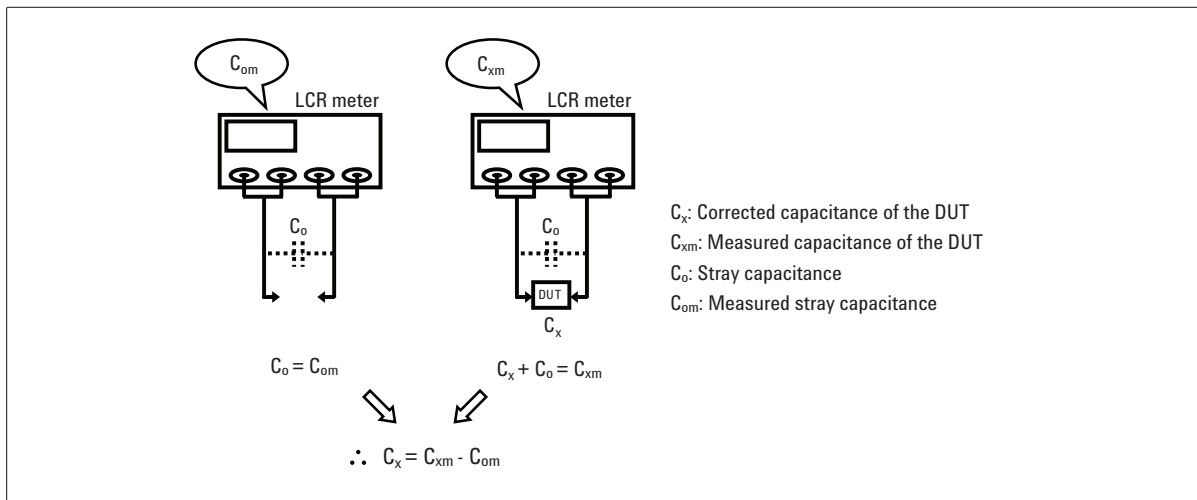


Figure 4-3. Offset compensation

4.3.2 Open and short compensations

Open and short compensations are the most popular compensation technique used in recent LCR measurement instruments. This method assumes that the residuals of the test fixture can be represented by the simple L/R/C/G circuit as shown in Figure 4-4 (a). When the DUT contact terminals of the test fixture are open, as shown in Figure 4-4 (b), stray admittance $G_o + j\omega C_o$ is measured as Y_o because residual impedance (Z_s) is negligible, ($1/Y_o \gg Z_s$). When the DUT contact terminals of the test fixture are shorted, as shown in Figure 4-4 (c), the measured impedance represents residual impedance $Z_s = R_s + j\omega L_s$ because Y_o is bypassed. As a result, each residual parameter is known and, the DUT's impedance (Z_{dut}) can be calculated from the equation given in Figure 4-4 (d).

Note: Keysight's impedance measurement instruments actually use a slightly different equation. Refer to Appendix B for more detailed information.

This compensation method can minimize the errors when the actual residual circuit matches the assumed model in the specific situations listed below:

- Measurement by connecting a Keysight test fixture to the UNKNOWN terminals
- Measurement with a Keysight test fixture connected by a Keysight test cable that is compensated for electrical length

In other situations, the open/short compensation will not thoroughly correct the measured values. In addition, this method cannot correlate measurement results from different instruments. To resolve these compensation limitations, the open/short/load compensation is required. Refer to "Open/short/load compensation" described in Section 4.3.3.

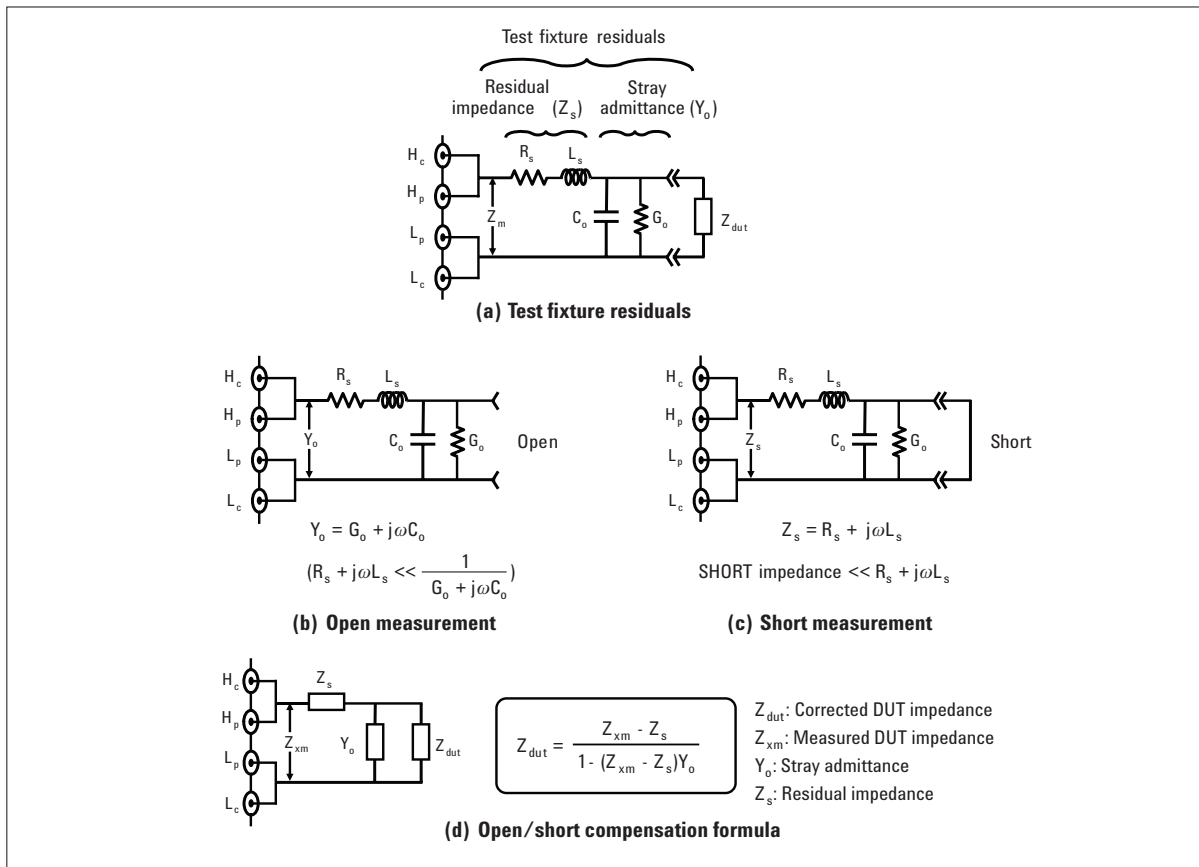


Figure 4-4. Open/short compensation

Precautions for open and short measurements

Open measurement must be performed so that it accurately measures the stray capacitance. To do this, keep the distance between the test fixture terminals the same as when they are holding the DUT. In addition, set the integration time, averaging, and test signal level so that the instrument measures with maximum accuracy. If an open measurement is performed under improper conditions, stray admittance (Y_o) is not correctly measured, resulting in an open compensation error.

Short measurement is performed by connecting the test fixture terminals directly together or by connecting a shorting device to the terminals. The residual impedance of the shorting device should be much lower than the DUT's impedance, otherwise it will directly affect the measurement results. Figure 4-5 shows an example of a shorting device that is applicable to the Keysight 16047A, and 16047D test fixtures. This shorting bar (Keysight part number 5000-4226) typically has residuals of 20 nH and 1 m Ω . Hence, the shorting bar is not suitable for low impedance measurement. For very low impedance measurement, you should use a test fixture in which the fixture terminals can be connected directly together.

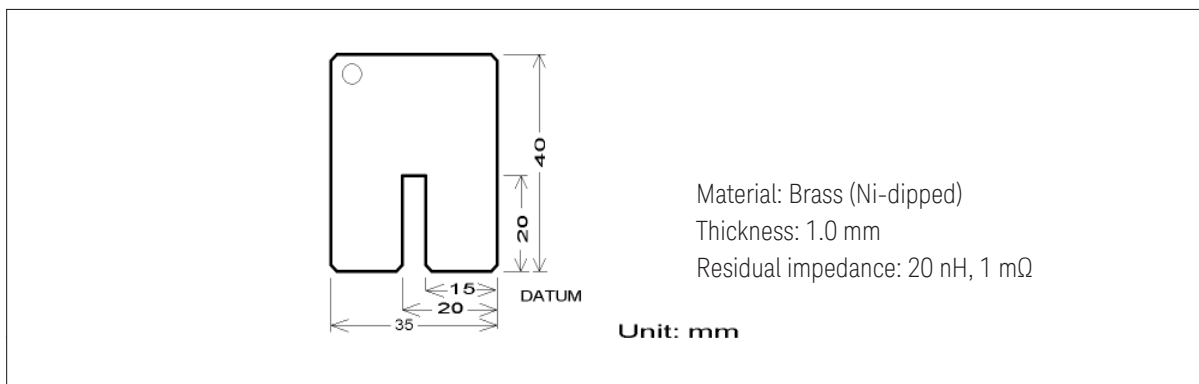


Figure 4-5. Example of shorting device (Keysight part number 5000-4226)

4.3.3 Open/short/load compensation

There are numerous measurement conditions where complicated residual parameters cannot be modeled as the simple equivalent circuit in Figure 4-4. Open/short/load compensation is an advanced compensation technique that can be applied to complicated residual circuits. To carry out the open/short/load compensation, three measurements are required before measuring the DUT, with the test fixture terminals opened, shorted, and with a reference DUT (load) connected. These measurement results (data) are used for compensation calculation when the DUT is undergoing measurement. As shown in Figure 4-6, the open/short/load compensation models the test fixture residuals as a four-terminal network circuit represented by the ABCD parameters. Each parameter value is derived by calculation if three conditions are known and if the four-terminal circuit is a linear circuit. The details of the calculation method for the open/short/load compensation are described in Appendix C.

The open/short/load compensation should be used in the following situations:

- (1) An additional passive circuit or component (e.g. external DC bias circuit, balun transformer, attenuator and filter) is connected.
- (2) A component scanner, multiplexer, or matrix switch is used.
- (3) Non-standard length test cables are used or 4TP extension cables are connected in series with Keysight test cables.
- (4) An amplifier is used to enhance the test signal.
- (5) A component handler is used.
- (6) A custom-made test fixture is used.

In the cases listed above, open/short compensation will not work effectively and the measurement result contains some error. It is not necessary to use the open/short/load compensation for simple measurement, like measuring an axial leaded component using the Keysight 16047A test fixture. The open/short compensation is adequate for such measurements.

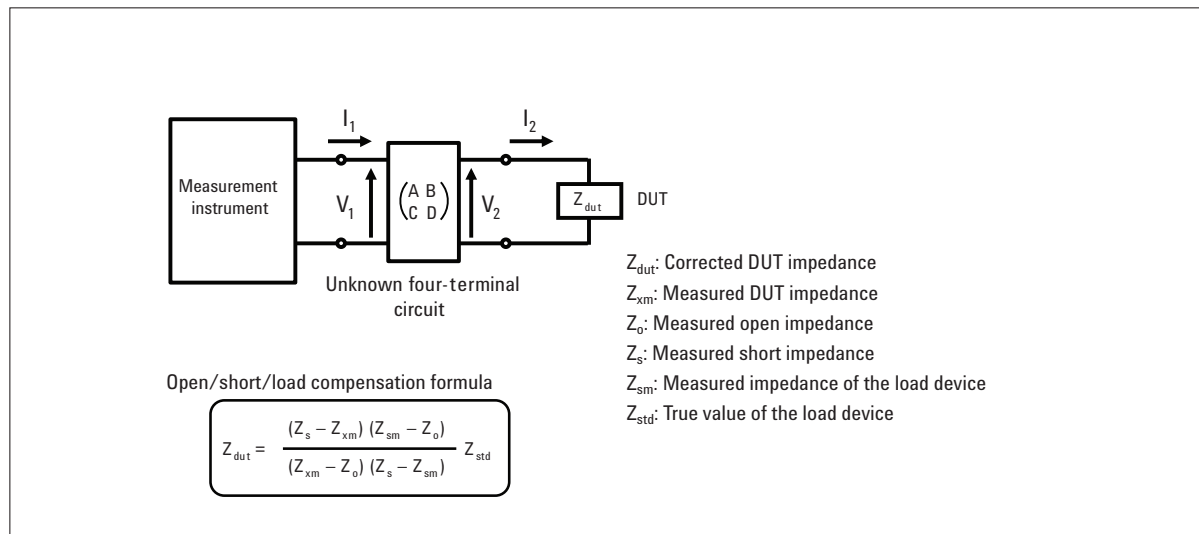


Figure 4-6. Open/short/load compensation

4.3.4 What should be used as the load?

The key point in open/short/load compensation is to select a load whose impedance value is accurately known. The criteria is as follows.

Use a stable resistor or capacitor as the load device.

The load device's impedance value must be stable under conditions of varying temperature, magnetic flux, and other component dependency factors. So, avoid using inductors that are relatively sensitive to measurement conditions for the load.

Use a load of the same size and measure it in the same way as the DUT will be measured.

As shown in Figure 4-7, if the load is measured under different electrode conditions, its measured data will not effectively compensate for the residuals. It is a good idea to use one of the actual DUTs as a working standard. If the load is a different type from the DUT (e.g. load is C and the DUT is R), at least keep the same distance between the electrodes.

Use a load that is close in value to the DUT.

Whatever the load value is, the load compensation is effective over the entire measurement range if the measurement circuit has a linear characteristic. In practice, the circuit between the UNKNOWN terminals and the DUT may have a non-linear factor, especially when an additional circuit includes a non-linear component such as an inductor, active switch, amplifier, etc. As shown in Figure 4-8, additional measurement error will be added when the measured DUT value is far from the load value used for the compensation. So, the impedance value of the load should be as close as possible to that of the DUT to be measured. If various impedances are to be measured, select a load that is nearly the center value of the DUT's impedance range. In addition, the load value should not be near the open or short impedance. Otherwise, the load compensation will not be effective and the result of the open/short/load compensation will be much the same as (or even worse than) that of the open/short compensation.

Use an accurately known load value.

The impedance value of the load must be known before performing the open/short/load compensation. To measure the load value, it is practical to use the same measurement instrument, but under the best possible measurement conditions. Set the measurement time, averaging, and test signal level so that the instrument can measure the load with maximum accuracy. Also, use a test fixture that mounts directly to the instrument. Figure 4-9 shows an example of such a measurement.

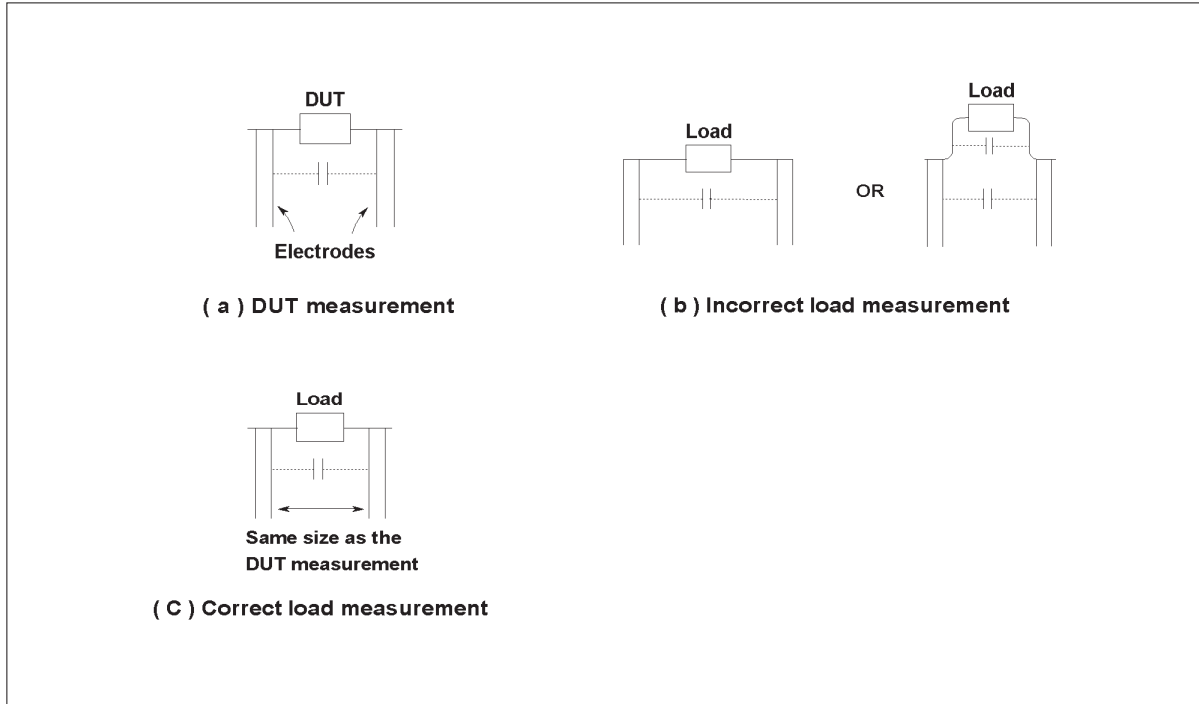


Figure 4-7. Electrode distance in load measurement

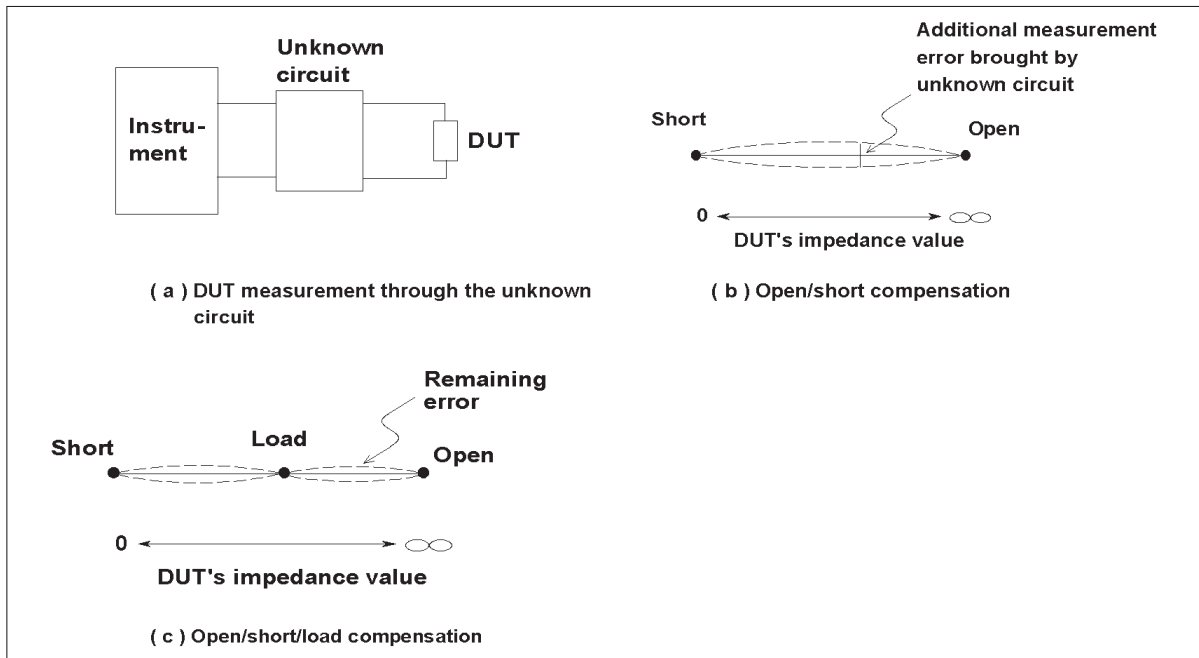


Figure 4-8. Load value must be close to the DUT's value

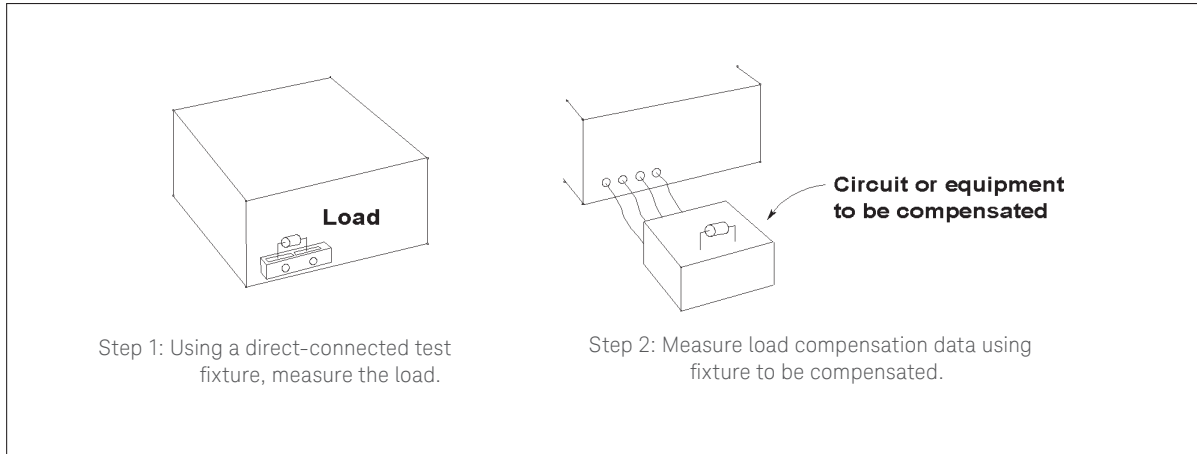


Figure 4-9. Actual open/short load measurement example

4.3.5 Application limit for open, short, and load compensations

When the residuals are too significant compared to the DUT's impedance value, compensation may not work properly. For example, if the measured short impedance (Z_{sm}) is about the same as the DUT's impedance, total measurement error will be doubled. The following are typical criteria for this limitation:

- (1) Measured open impedance (Z_{om}) must be more than 100 times the measured impedance of the DUT.
- (2) Measured short impedance (Z_{sm}) should be less than 1/100 of the measured impedance of the DUT.

4.4 Measurement error caused by contact resistance

Any contact resistance existing between the DUT electrodes and the contact electrodes of the test fixture or test station will result in measurement error. The effects of the contact resistance are different for the DUT connection methods, 2T and 4T. In the case of a 2T connection, the contact resistance is added to the DUT impedance in series and produces a positive error in the dissipation factor (D) reading (see Figure 4-10 (a).) In the case of a 4T connection, contact resistances R_{hc} , R_{hp} , R_{lc} , and R_{lp} exist as shown in Figure 4-10 (b.) The effects of the contact resistance differ depending on the terminals. R_{hc} decreases the test signal level applied to the DUT, but it does not directly produce measurement error. R_{lp} may cause the auto-balancing bridge to be unstable, but generally its effect is negligible. R_{hp} and Ch_p (distributed capacitance of the coaxial test cable) form a low-pass filter, which causes attenuation and phase shift of the H_p input signal, producing measurement error. R_{lc} and Cl_c also form a low-pass filter and cause an error in measured DUT current and phase angle. Since the resultant dissipation factor error is proportional to $-\omega R_{hp} \times Ch_p$ and $-\omega R_{lc} \times Cl_c$, the D error is a negative value and increases with frequency. This error becomes significant when the 4T connection method is used in high frequency measurements. The 4T connection gives a constant D error (that is determined by the contact resistance and test lead capacitance only) while the error of the 2T connection varies depending on the DUT's value (Figure 4-10 (c).) The 4T connection provides minimal error only when the effects of contact resistance and test lead capacitance are negligible (mainly at low frequencies.)

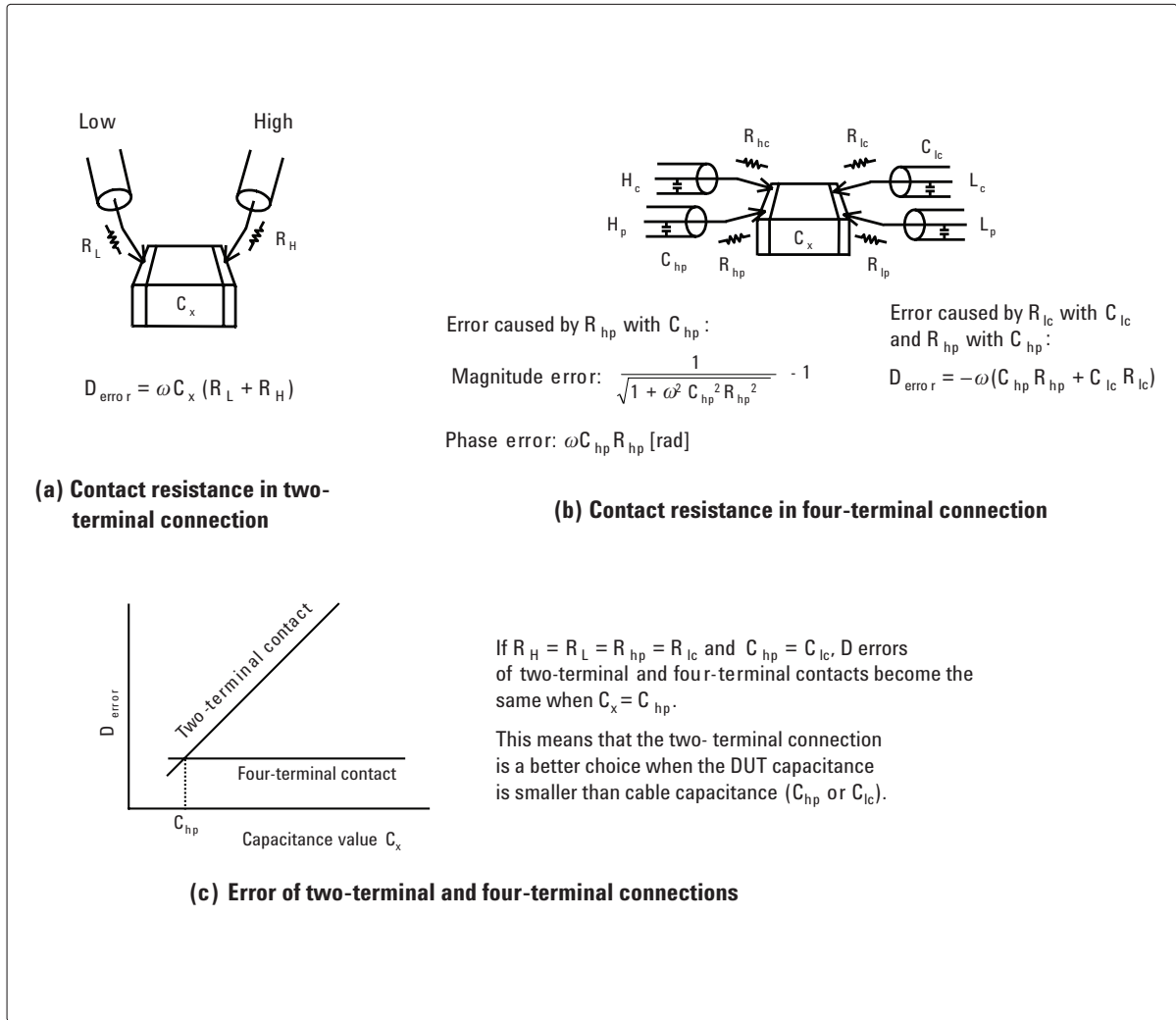


Figure 4-10. Effect of contact resistance

4.5 Measurement error induced by cable extension

4.5.1 Error induced by four-terminal pair (4TP) cable extension

A simplified schematic of test cable extension for the auto-balancing bridge instrument is shown in Figure 4-11. Extending a 4TP measurement cable from the instrument will cause a magnitude error and phase shift of the measurement signal according to the extension cable length and measurement frequency.

The following two problems will arise from the cable extension:

- (1) Bridge unbalanced
- (2) Error in the impedance measurement result

Bridge unbalance is caused by the phase shift in the feedback loop that includes the range resistor, (R_r), amplifier, and the L_p and L_c cables. If the L_p or L_c cable is too long, it causes a significant change in phase angle of range resistor current (I_{R_r}) flowing through the feedback loop. The vector current (I_{R_r}) cannot balance with the DUT current vector because of the phase error and, as a result the unbalance current that flows into the L_p terminal is detected by the unbalance detector (which annunciates the unbalance state to digital control section.) Some instruments such as the Keysight 4294A impedance analyzer can compensate for the effect of a long extension cable by producing an intentional phase shift in the feedback loop.

The bridge unbalance is also caused by a standing wave (an effect of reflection) generated when the cable length is not sufficiently shorter than the test signal wavelength. A guideline for the cable length limitation caused by this effect is given by the following equation (as described in Section 3.3.3.)

$$F \text{ [MHz]} \times L \text{ [m]} \leq 15$$

The errors in impedance measurement results are mainly caused by the phase shift, attenuation, and reflection of test signal on the cables connected to the H_p and L_c terminals. These errors can be corrected by the instrument if the propagation constants and the length of the cable are known.

These two problems are critical only at high frequencies (typically above 100 kHz), and Keysight's impedance measurement instruments can compensate for Keysight-supplied test cables. In the lower frequency region, the capacitance of the cable will only degrade the measurement accuracy without affecting the bridge balance. This effect of the cable extension is shown in Figure 4-12.

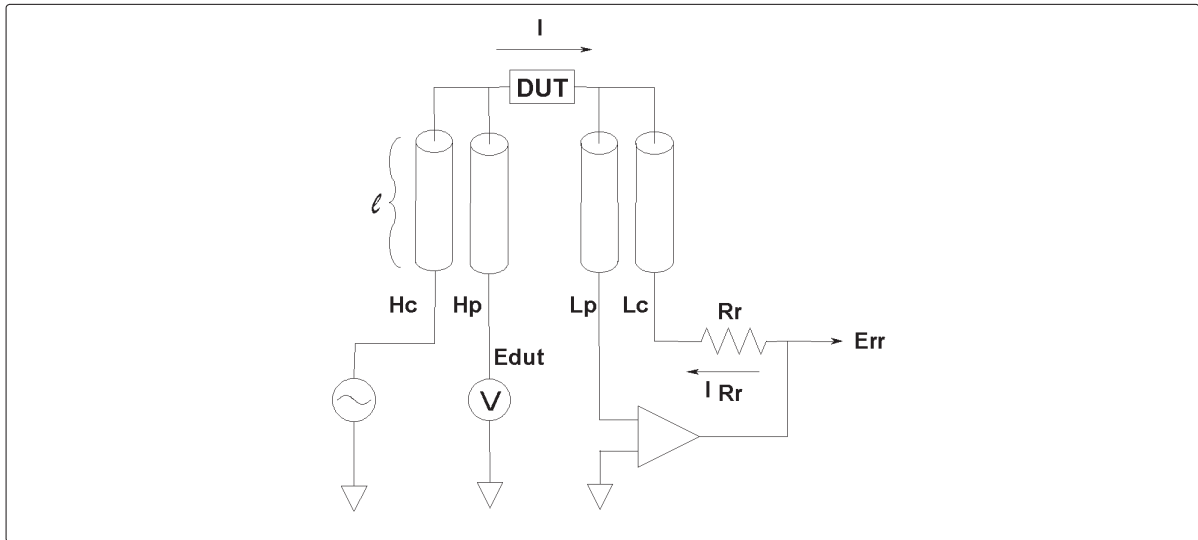


Figure 4-11. Cable length correction

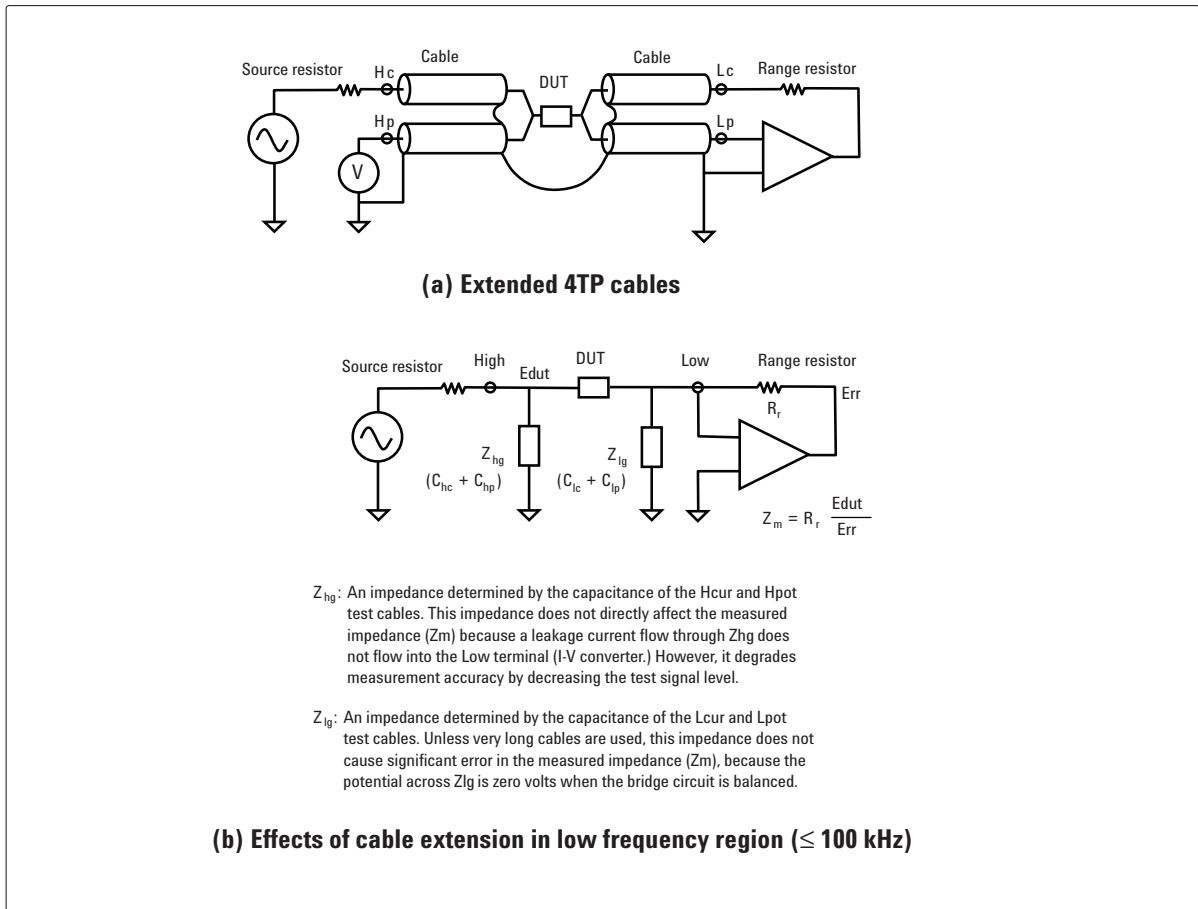


Figure 4-12. Measurement error due to extended cable length

The cable length correction works for test cables whose length and propagation constants are known, such as the Keysight-supplied test cables of 1, 2, or 4 m. If different types of cable in different lengths are used, it may cause bridge unbalance in addition to measurement error.

In practice, the measurement error is different for the cable termination types of the instrument. High frequency 4TP instruments, such as the Keysight 4285A and the 4294A, which internally terminate cables with their characteristic impedance, differ from low frequency 4TP instruments without cable termination.

4.5.2 Cable extension without termination

Extending test cable from the 4TP instrument without cable termination will produce an impedance measurement error, which is typically given by the following equation:

$$\text{Error} = k \times \Delta L \times f^2 (\%)$$

Where, k: A coefficient specific to the instrument
 ΔL : Cable length difference (m) from standard length (cable length setting)
 f: Measurement frequency (MHz)

The k value is a decimal number mostly within the range of -1 to +1 and is different depending on instruments. As the above equation shows, the error rapidly increases in proportion to the square of measurement frequency. Using the open/short compensation will not reduce this error. Only the open/short/load compensation can minimize this error.

4.5.3 Cable extension with termination

Extending the test cables from the instrument with cable termination will not produce a large error for the magnitude of measured impedance (because the effect of reflections is decreased.) However, it causes a phase error in proportion to the extension length and measurement frequency. (In practice, an error for the magnitude of impedance also occurs because the actual cable termination is not ideal.) Performing the open/short/load compensation at the end of the cable can eliminate this error.

4.5.4 Error induced by shielded 2T or shielded 4T cable extension

When the 4TP test cables and the shielded 2T (or shielded 4T) extension cables are connected in series as shown in Figures 3-13 and 3-14, the cable length limitation and measurement error (discussed in Sections 4.4.2 and 4.4.3) apply to the 4TP test cables only. The cable extension portion in the shielded 2T or shielded 4T configuration does not cause the bridge unbalance, but produces additional impedance measurement error. There are some error sources specific to the shielded 2T or shielded 4T configuration (as described in Sections 3.1.2 and 3.1.4) in the cable extension portion. In this case, different compensation methods are applied to the 4TP test cables and the cable extension portion, respectively.

Keysight-supplied test cables should be used in order to apply the cable length correction to the 4TP test cables. The cable length correction moves the calibration plane to the tip of the 4TP test cables from the UNKNOWN terminals. To minimize errors, perform the cable length correction for the Keysight test cables and then the open/short/load compensation at the tip of extension cables. When the cable extension is sufficiently short and is used in the low frequency region, the open/short compensation can be used in place of the open/short/load compensation. Note that the cable length correction must be done to avoid the bridge unbalance caused by the phase shift of the measurement signal in the 4TP test cables.

4.6 Practical compensation examples

The error sources present in a practical measurement setup are different for the configuration of test fixtures, test cables, or circuits which may be connected between the instrument and the DUT. Appropriate compensation methods need to be applied depending on the measurement configuration used. Figure 4-13 shows examples of the compensation methods that should be used for typical measurement setups.

4.6.1 Keysight test fixture (direct attachment type)

When a Keysight direct attachment type test fixture is used, open/short compensation is enough to minimize the additional measurement errors. Since the characteristics of Keysight test fixtures can be properly approximated by the circuit model shown in Figure 4-4, the open/short compensation effectively removes the errors. Open/short/load compensation is not required as long as the fundamental measurement setup is made as shown in Figure 4-13 (a).

4.6.2 Keysight test cables and Keysight test fixture

When Keysight test cables and a Keysight test fixture are connected in series as shown in Figure 4-13 (b), perform the cable length correction first. The cable length correction moves the calibration plane to the tip of the test cables. Then, perform the open/short compensation at the DUT terminals of the test fixture in order to minimize the test fixture induced errors.

4.6.3 Keysight test cables and user-fabricated test fixture (or scanner)

When Keysight test cables and a user-fabricated test fixture are connected in series as shown in Figure 4-13 (c), perform the cable length correction first in order to move the calibration plane to the tip of the test cables. The characteristics of the user-fabricated test fixture are usually unknown. Thus, the open/short/load compensation should be performed to effectively reduce the errors even if the test fixture has complicated residuals.

4.6.4 Non-Keysight test cable and user-fabricated test fixture

When a non-Keysight test cable and a user-fabricated test fixture is used, the 4TP measurement is basically limited to the low frequency region. In the higher frequency region, this type of test configuration may produce complicated measurement errors or, in the worst cases, cause the bridge unbalance which disables measurements. When measurement setup is made as shown in Figure 4-13 (d), the cable length correction cannot be used because it will not match the characteristics of the non-Keysight cables. As a result, the calibration reference plane stays at the instrument's UNKNOWN terminals (as shown in Figure 4-1 (a).) Initially, verify that the bridge unbalance does not arise at the desired test frequencies. Next, perform the open/short/load compensation at the DUT terminals of the test fixture. This method can comprehensively reduce measurement errors due to the test cables and fixture.

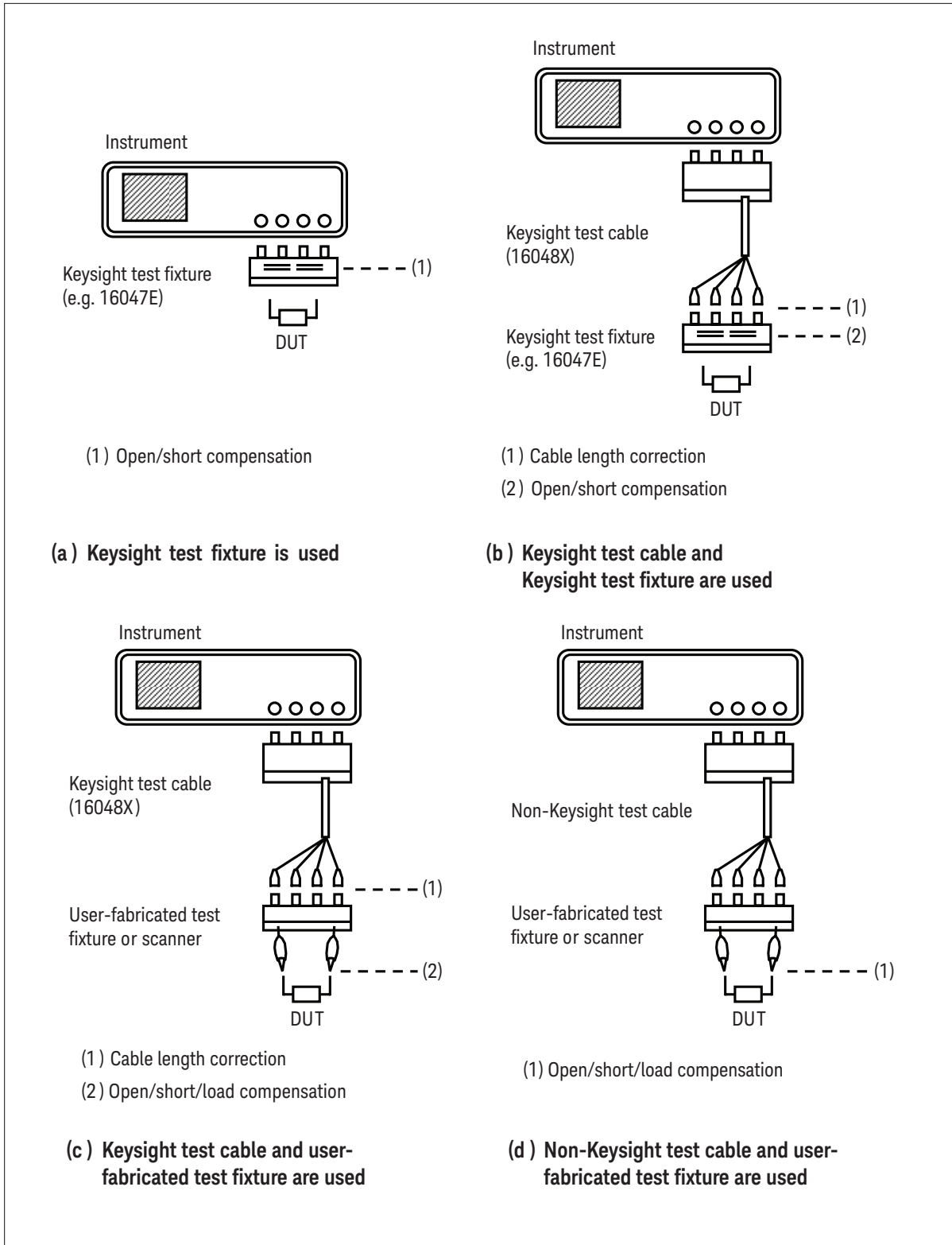


Figure 4-13. Compensation examples

4.7 Calibration and compensation in RF region

4.7.1 Calibration

Whether the RF I-V method or network analysis, the open, short, and load calibration minimizes instrument inaccuracies. To perform calibration, open, short, and load reference terminations are connected to the test port and each of the terminations is measured. This calibration data is stored in the instrument's memory and used in the calculation to remove the instrument errors. Impedance values of these reference terminations are indicated in both vector impedance coordinates and a Smith chart in Figure 4-14.

Note: A 7-mm coaxial connector has a fringe capacitance of typically 0.082 pF when terminated with Open. This fringe capacitance value has been memorized in the instrument and is used to calculate accurate open calibration data.

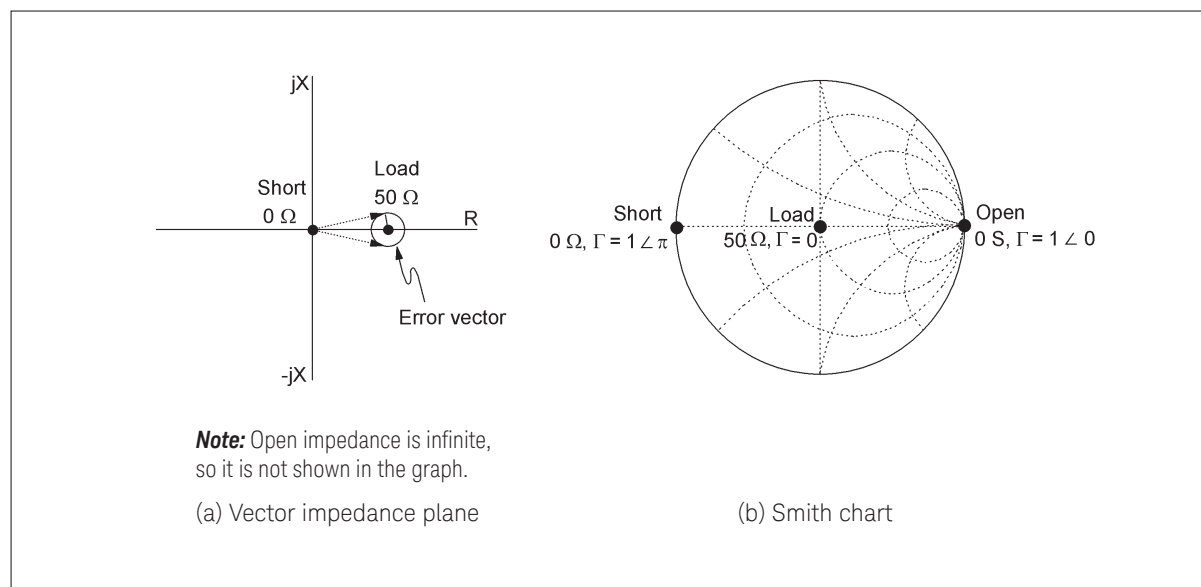


Figure 4-14. Calibration standard values

Though all three terminations are indispensable for calibration, the load termination impedance ($50\ \Omega$) is particularly important for precise calibration and has a large influence on resultant measurement accuracy. The uncertainty of the load termination impedance is represented by a circle that encloses the error vector (see Figure 4-14 (a.)) The uncertainty of its phase angle increases with frequency and becomes a considerable error factor, especially in measurements of high Q (low ESR or low D) devices at high frequencies.

To improve accuracy for the high Q (low loss) measurement, the RF I-V measurement instrument can be calibrated using a low loss capacitor (LLC) termination in addition to the open/short/load terminations. The LLC provides a reference for calibration with respect to the 90° -phase component of impedance. As a result, the instrument can measure high Q (low dissipation factor) devices more accurately than when basic open/short/load calibration is performed. The LLC calibration takes place only in the high frequency range (typically above 300 MHz) because the phase angle of the load impedance is accurate at relatively low frequencies.

When the test port is extended, calibration should be performed at the end of extension cable, as discussed in Section 3. Thereby, the calibration plane is moved to the end of cable.

To perform measurements to meet specified accuracy, the instrument should be calibrated before the measurement is initiated and each time the frequency setting is changed. The calibration defines the calibration reference plane at which measurement accuracy is optimized.

If a component could be measured directly at the calibration plane, it would be possible to obtain measured values within the specified accuracy of the instrument. However, the real-world components cannot be connected directly to the calibrated test port and a suitable test fixture is used for measurements. Calibration is not enough to measure the DUT accurately. Because measurement is made for the DUT connected at the contact terminals of the test fixture (different from calibration plane), the residual impedance, stray admittance, and electrical length that exist between the calibration plane and the DUT will produce additional measurement errors. As a result, compensation is required to minimize those test fixture induced errors.

4.7.2 Error source model

Regarding ordinary, non-coaxial test fixtures, consider an error source model similar to that in low frequency measurements. Figure 4-15 (a) illustrates a typical test fixture configuration and a model of error sources. The test fixture is configured with two electrically different sections: a coaxial connector section and a non-coaxial terminal section for connecting the DUT. The characteristic of the coaxial section can be modeled using an equivalent transmission line (distributed constant circuit) and represented by propagation constants. Normally, as the coaxial section is short enough to neglect the propagation loss, we can assume that only the phase shift (error) expressed as electrical length exists. The characteristic of the non-coaxial section can be described using the residual impedance and stray admittance model in a two-terminal measurement configuration as shown in Figure 4-15 (b). We can assume residual impedance (Z_s) is in series with the DUT and stray admittance (Y_o) is in parallel with DUT.

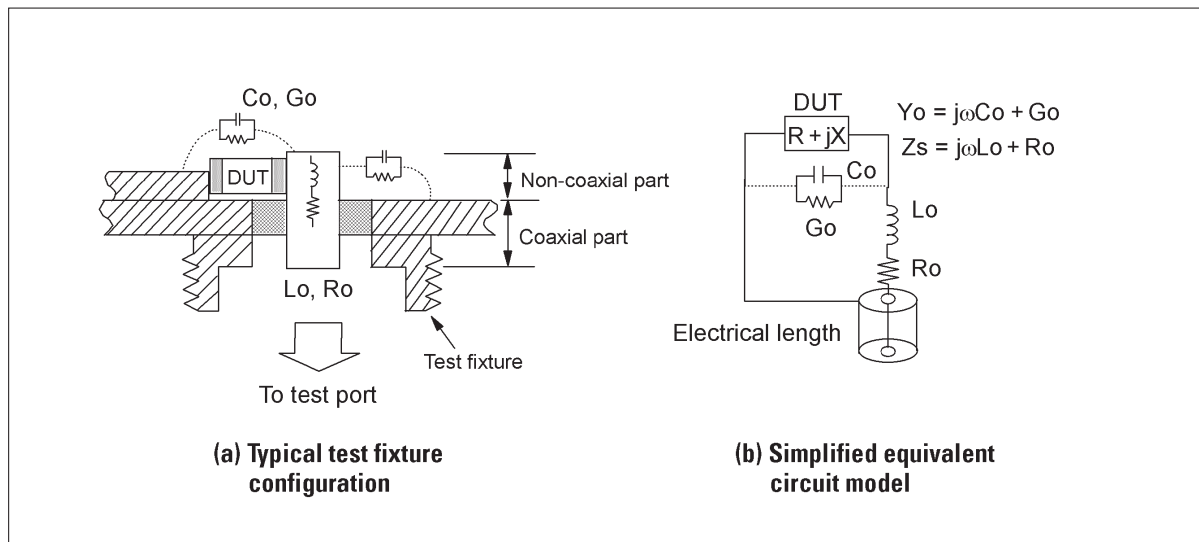


Figure 4-15. Typical error source model

4.7.3 Compensation method

As the error source model is different for the coaxial and non-coaxial sections of the test fixture, the compensation method is also different.

Electrical length compensation eliminates measurement errors induced by the phase shift in the coaxial section. Keysight RF impedance analyzers and RF LCR meters facilitate the electrical length compensation by allowing you to choose the model number of the desired test fixture from among the displayed list, instead of entering the specified electrical length of that test fixture to the instrument. (It is also possible to input the specified electrical length value.)

Open/short compensation is effective for residuals in the non-coaxial section. It is based on the same compensation theory as described for low frequency measurements. (Refer to Section 4.3.2 for details.) The Y_o and Z_s can be determined by measuring with the contact terminals opened and shorted, respectively.

As the test fixture is configured with the coaxial and non-coaxial sections, both compensations are required to minimize combined errors. Load compensation is not required for normal measurements using Keysight-supplied test fixtures.

When a test port extension or a user-fabricated test fixture is used, error sources will not match the model assumed for the open/short compensation and they will affect measurement results. In such cases that measurement errors cannot be removed sufficiently, consider attempting the open/short/load compensation. Actually, the open/short/load compensation is substituted by the open/short/load calibration using working-standard devices because these two functions are equivalent to each other. Note that when the open/short/load calibration is executed at measurement terminals, the test port calibration data is invalidated (because the calibration plane is moved.) Consequently, measurement accuracy depends on the calibrated accuracy of the short and load working-standard devices (open calibration requires no device) as well as the proper contact when these standard devices are inserted into the test fixture. It is important that special consideration be given to the precision of the standard values, contact resistance, and positioning of the standard device on the test fixture.

4.7.4 Precautions for open and short measurements in RF region

To discuss calibration and compensation issues, we need to consider how residual parameters have large effects on measurement results at high frequencies.

Assume that, for example, a residual inductance of 0.1 nH and a stray capacitance of 0.1 pF exist around the measurement terminals of the test fixture. Notice how the effects of these small residuals differ depending on frequency. Relationships of the residual parameter values to the typical impedance measurement range are graphically shown in Figure 4-16. In the low frequency region, the residual parameter values are much smaller than the values of normally measured devices. It is because the capacitors and inductors, which are designed for use in low frequency electronic equipment, possess large values compared to small residuals. In the high frequency region, however, devices such as those employed for higher frequency circuits and equipment have lower values. In the frequency range typically above 100 MHz, the majority of the DUTs are low value devices (in the low nanohenries and the low picofarads) and their values come close to the values of the residuals.

Accordingly, the residual parameters have greater effects on higher frequency measurements and become a primary factor of measurement errors. The accuracy of measurement results after compensation depends on how precisely the open/short measurements have been performed.

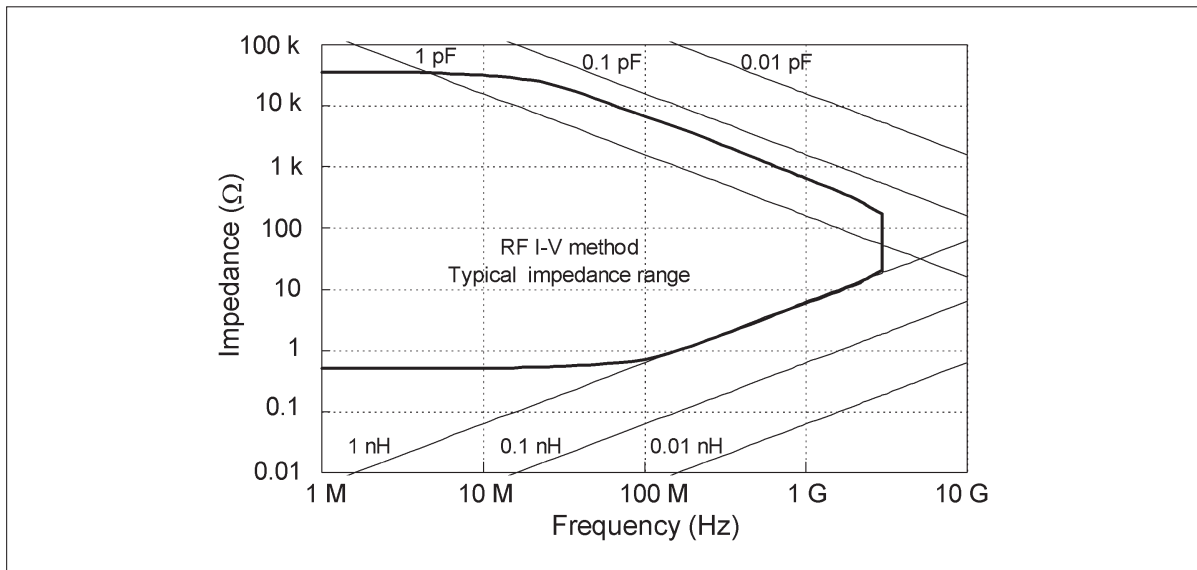


Figure 4-16. Relationship of residual parameter values to the typical impedance measurement range of the RF I-V method

To perform optimum compensation, observe the precautions for open/short measurements described in Section 4.3.2. In the high frequency region, the method of open/short compensation dominates the measurement correlation. To obtain measurement results with a good correlation and repeatability, the compensation must be performed with the same conditions. A difference in the compensation method will result in a difference in measured values, leading to correlation problems on measurement results. Short measurement is more critical in terms of increasing the need for low inductance measurements.

4.7.5 Consideration for short compensation

To make the short measurement at the contact terminals of a test fixture or of a component handler, a short bar (chip) is usually employed. When measuring very low impedance (inductance), the following problems arise from the short bar:

- Different residual impedance is dependent on size and shape
- Method of defining the residual impedance

If a different size or shape of the short bar is used, it is difficult to obtain a good correlation of the measurement results. The residual impedance of the short bar is different if the size differs. Hence, the same size of short bar must be used when making the short measurement.

If the definition of the short bar's impedance is different, it causes a difference in measured values. To have a good correlation, it is desirable to determine the short bar's residuals. However, it cannot be determined only from the inherent impedance of the short bar itself. The actual impedance depends on surrounding conditions such as contact terminals, thickness of the closely located conductors, permittivity of insulators, ground conditions, etc.

Conceptually, there are two methods for defining the short bar's impedance. One is to assume the impedance is zero. This has been a primordial method of defining the short impedance. In this definition method, the measurement result is a relative value of the DUT to the short bar. The other method is to define the short bar's inductance as $x \times H$. (Residual resistance is negligible for a small short bar.) In this method, the measurement result is deemed as the absolute value of the DUT. The residual inductance of the short bar is estimated from physical parameters (size and shape) and is used as a reference. To estimate the inductance, the short bar needs to meet conditions, where theoretical derivation is possible.

The measurement results from both definition methods are correct. The difference in the measurement result is attributable to the difference in the definition. Practically, because of these incompatible definitions, a problem will emerge when yielding correlation. To avoid this type of problem, it is necessary to establish an agreement on the short bar's size, shape, and the definition method of the residual inductance.

Note: Each of the Keysight 16196A/B/C/D coaxial test fixtures has a short device whose value is theoretically definable. Since a 50Ω coaxial configuration is established for the whole signal flow path, including the short device placed in the fixture, the theoretical inductance value of the short device can be calculated from the length and physical constants by using a transmission line formula. Its reference value is documented; however, the use of the 16196A/B/C/D is not subject to the execution of the compensation based on the reference value. You need to select the definition method of short inductance that agrees with your measurement needs.

The chip-type short devices and load devices are readily available from the working-standard set supplied for Keysight RF I-V measurement instruments. Otherwise, you can substitute appropriate devices for the short and load chips by accurately determining (or properly defining) their characteristics.

4.7.6 Calibrating load device

To determine the values of a load device, you can use the same instrument that will be used to measure the DUTs. The appropriate procedure for calibrating the load device is described below:

- (1) Perform open/short/load calibration at the instrument's test port. In addition, for a capacitive or an inductive load device, it is recommended that low loss capacitor calibration be performed.
- (2) Connect a direct-mounting type test fixture to the test port. It is recommended that the 16196A/B/C/D coaxial test fixtures be used to insure the best measurement accuracy.
- (3) Perform open and short compensation. For short measurement, the method of minimizing short impedance must be employed. (To do this, contact the terminals directly together if possible.) When the 16196A/B/C/D is used, consider inputting the reference value of the residual inductance of the furnished short device to the instrument. (Using the reference value is contingent upon how the reference of short inductance needs to be defined for your measurement. Keysight chooses to take the historic approach to let Short = $0 H$, but the actual user of the test fixture can choose either approach.)
- (4) Connect the load device to the test fixture, select the parameters available for the instrument's load calibration function (typically R-X, L-Q, L-Rs, and C-D) and measure the device. Set the measurement time, test signal level, and averaging so that the instrument can measure the load with maximum accuracy (or use the specified test signal level of the device if required.)

4.7.7 Electrical length compensation

In the lower frequency region, using the open/short compensation function can minimize most of test fixture residuals. In the RF region, however, this is not enough to reduce the effect of the test fixture residuals. The wavelength of RF frequencies is short and is not negligible compared to the physical transmission line length of the test fixture. So, a phase shift induced error will occur as a result of the test fixture, and this error cannot be reduced by using open/short compensation. The phase shift can be compensated if the electrical length of the transmission line is known. As shown in Figure 4-17, both the electrical length compensation and open/short compensation should be performed after calibrating at the test port.

The electrical length compensation corrects phase error only and ignores propagation loss induced error. This is only effective when transmission line (test port extension) is short enough to neglect the propagation loss.

Note: Theoretical explanation for the effects of the electrical length and the compensation is given in Appendix D.

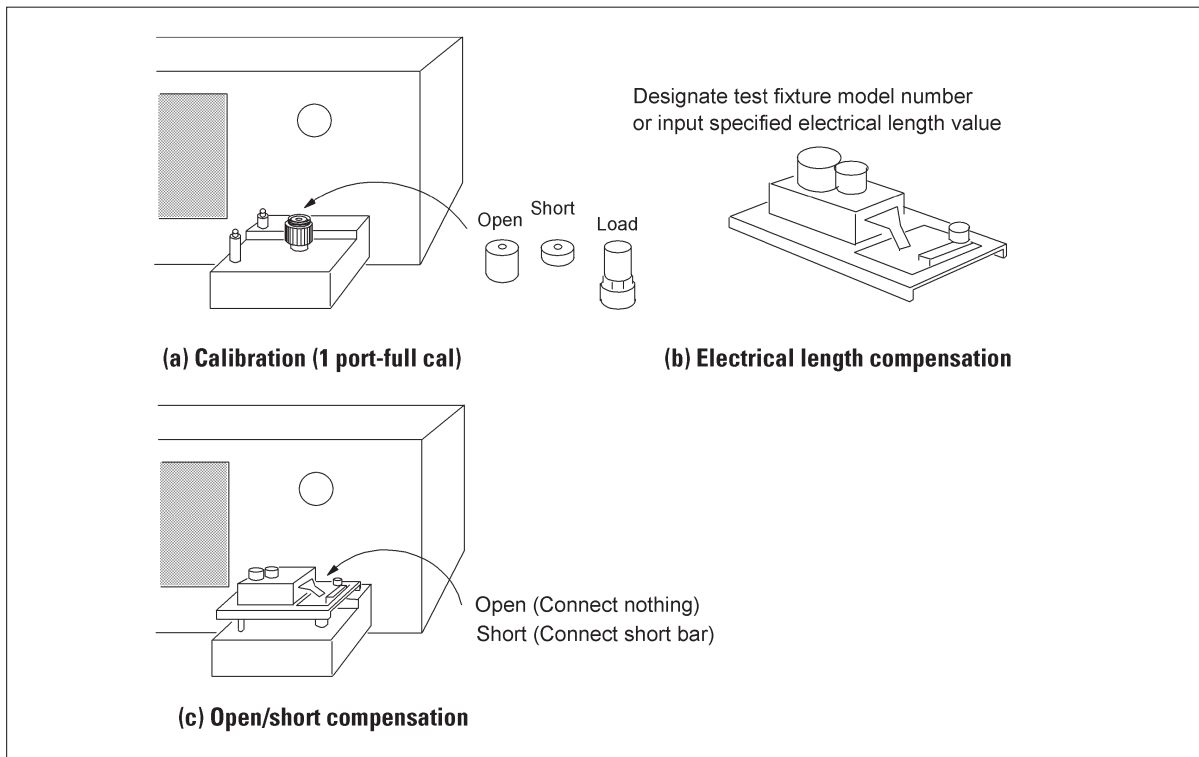


Figure 4-17. Complete calibration and compensation procedure

4.7.8 Practical compensation technique

The calibration and compensation methods suitable for measurement are different depending on how the test cable or fixture is connected to the test port. The following is a typical guideline for selecting appropriate calibration and compensation methods.

Measurements using an Keysight test fixture without a test port extension

To make measurements using a test fixture connected directly to the test port, first perform calibration at the test port. After calibration is completed, connect the test fixture to the test port and then perform electrical length compensation (for the test fixture's electrical length) and open/short compensation.

Measurement using a test port extension

When the measurement needs to be performed using a test port extension or a non-Keysight test fixture, it is recommended that the open/short/load calibration be performed at the measurement terminals of the test fixture. Typically, this method is applied when unknown devices are measured using a component handler. Because coaxial terminations do not match geometrically with the contact terminals of the test fixture or of the component handler, short and load devices whose values are defined or accurately known are required as substitution standards. (Open calibration requires no device.) Compensation is not required because measurements are made at the calibration plane.

4.8 Measurement correlation and repeatability

It is possible for different measurement results to be obtained for the same device when the same instrument and test fixture is used. There are many possible causes for the measurement discrepancies, as well as residuals. Typical factors for measurement discrepancies in RF impedance measurements are listed below.

- Variance in residual parameter value
- A difference in contact condition
- A difference in open/short compensation conditions
- Electromagnetic coupling with a conductor near the DUT
- Variance in environmental temperature

4.8.1 Variance in residual parameter value

Effective residual impedance and stray capacitance vary depending on the position of the DUT connected to the measurement terminals. Connecting the DUT to the tip of the terminals increases residual inductance compared to when the DUT is at the bottom. Stray capacitance also varies with the position of the DUT (see Figure 4-18.)

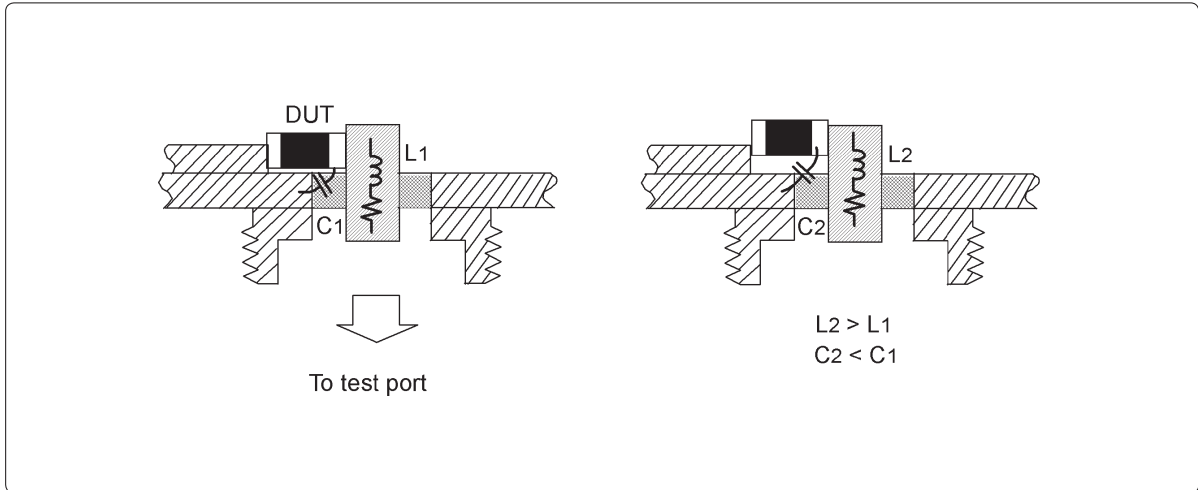


Figure 4-18. Difference in residual parameter values due to DUT positioning

4.8.2 A difference in contact condition

A change in the contact condition of the device also causes measurement discrepancies. When the device is contacted straight across the measurement terminals, the distance of current flow between the contact points is minimum, thus providing the lowest impedance measurement value. If the DUT tilts or slants, the distance of the current flow increases, yielding an additional inductance between the contact points (see Figure 4-19.) Residual resistance will also change depending on the contact points and produce a difference in measured D, Q, or R values. The positioning error affects the measurement of low value inductors and worsens the repeatability of measured values.

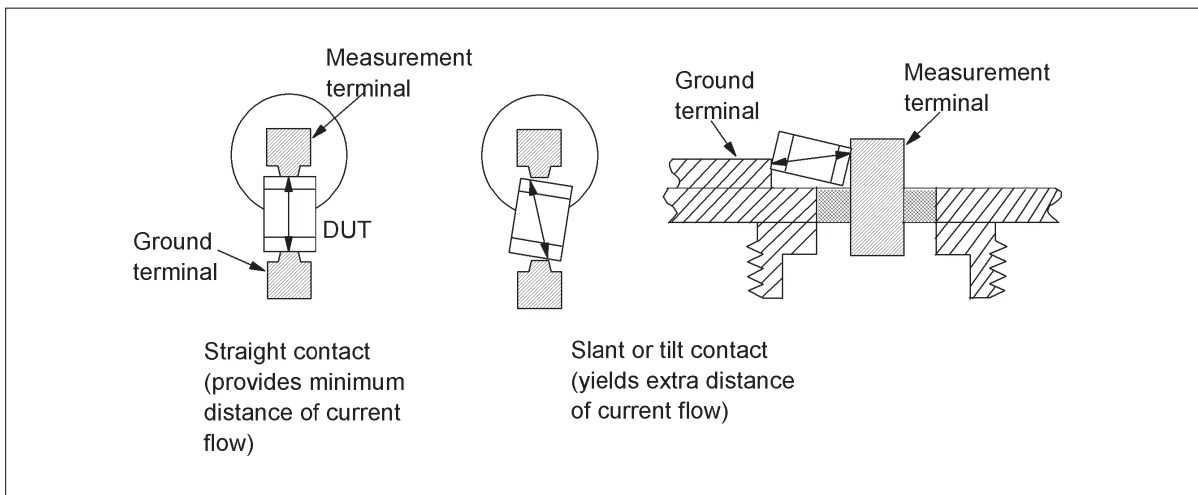


Figure 4-19. Measurement error caused by improper DUT positioning

4.8.3 A difference in open/short compensation conditions

Improper open/short measurements deteriorate the accuracy of compensated measurement results. If the open/short measurement conditions are not always the same, inconsistent measurement values will result. Each short device has its inherent impedance (inductance) value and, if not defined as zero or an appropriate value, the difference of the short device used will produce resultant measurement discrepancies. Effective impedance of the short device will vary depending on how it contacts to the measurement terminals. When the bottom-electrode test fixture is used, contact points on the measurement terminals will be different from the case of the parallel-electrode test fixture, as shown in Figure 4-20. If the short device is not straight (slightly curved), the measured impedance will be different depending on which side of the device comes upside. These effects are usually small, but should be taken into considerations especially when performing a very low inductance measurement, typically below 10 nH.

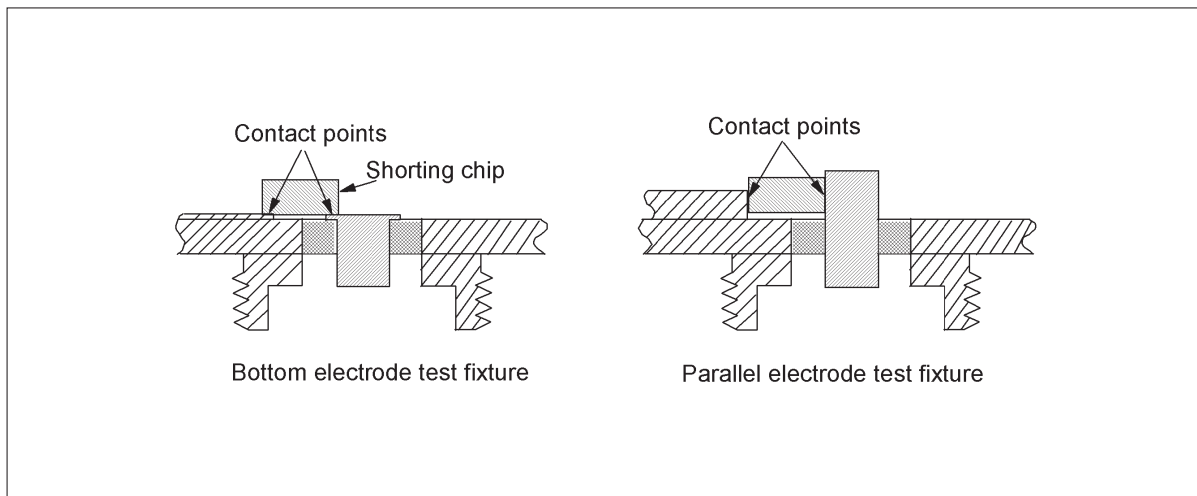


Figure 4-20. Difference in short impedance by test fixture types

4.8.4 Electromagnetic coupling with a conductor near the DUT

Electromagnetic coupling between the DUT and a metallic object near the DUT varies with mutual distance and causes variance in measured values. Leakage flux generated around inductive DUT induces an eddy current in a closely located metallic object. The eddy current suppresses the flux, decreasing the measured inductance and Q factor values. The distance of the metallic object from the DUT is a factor of the eddy current strength as shown in Figure 4-21 (a). As test fixtures contain metallic objects, this is an important cause of measurement discrepancies. Open-flux-path inductors usually have directivity in generated leakage flux. As a result, measured values will vary depending on the direction of the DUT. The difference in the eddy current due to the leakage flux directivity is illustrated in Figures 4-21 (b), (c), and (d).

If a parasitic capacitance exists between the DUT and an external conductor, it is difficult to remove the effect on measurement because the guarding technique is invalid. Thus, the DUT should be separated from the conductor with enough distance to minimize measurement errors.

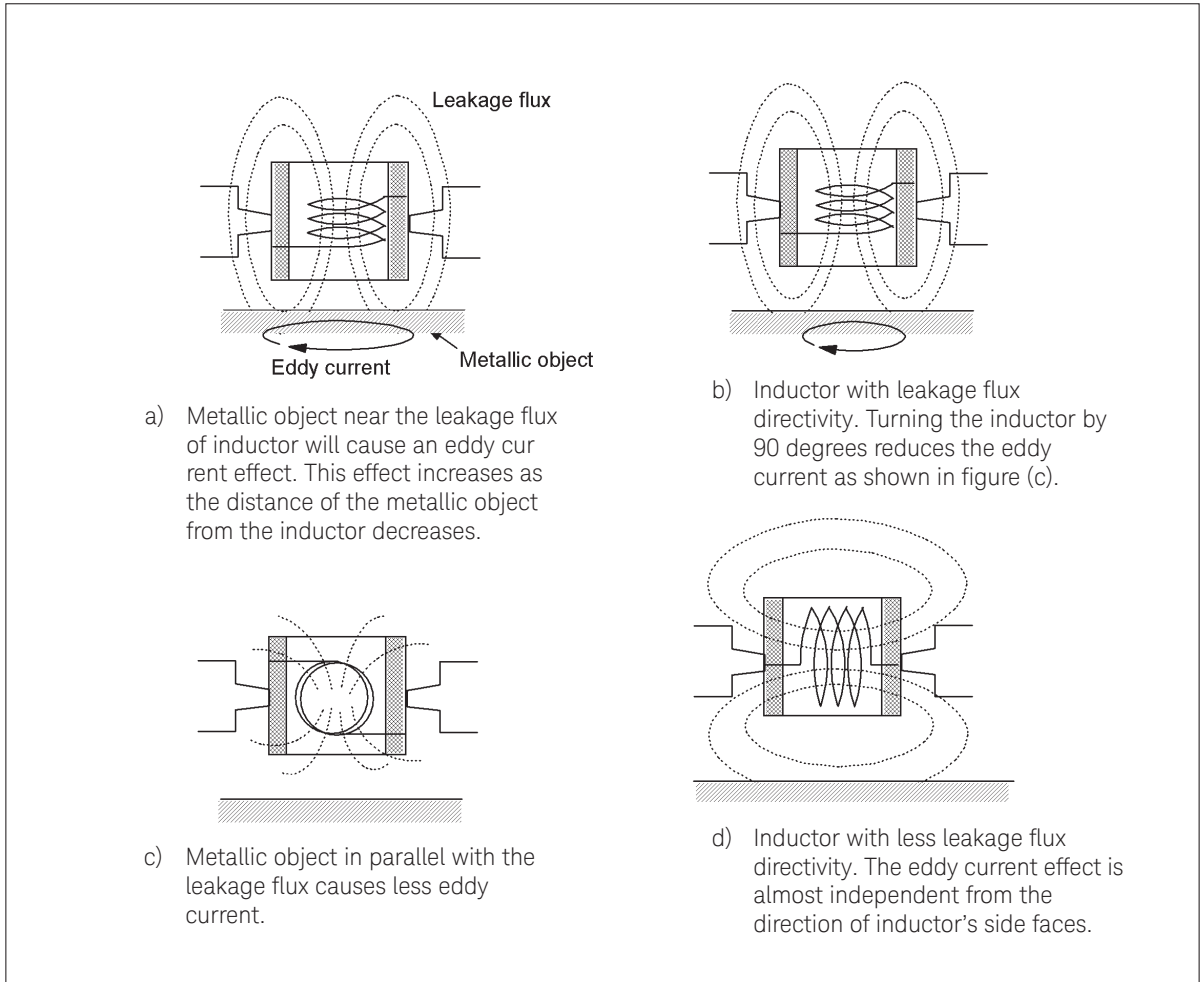


Figure 4-21. Eddy current effect and magnetic flux directivity of device

4.8.5 Variance in environmental temperature

Temperature influences the electrical properties of materials used for the test fixtures and cables. When the test port is extended using a coaxial cable, the dielectric constant of the insulation layer (between the inner and outer conductors) of the cable, as well as physical cable length, will vary depending on the temperature. The effective electrical length of the cable varies with the dielectric constants, thus resulting in measurement errors. Bending the cable will also cause its effective electrical length to change. Keep the extension cable in the same position as it was when calibration was performed.

5.0 Impedance Measurement Applications and Enhancements

Impedance measurement instruments are used for a wide variety of applications. In this section we present fundamental measurement methods and techniques used to make accurate and consistent measurements for various devices. Special measurement techniques, including the methods of enhancing the test signal level or DC bias level, are also covered to expand the range of impedance measurement applications.

5.1 Capacitor measurement

Capacitors are one of the primary components used in electronic circuits. The basic structure of a capacitor is a dielectric material sandwiched between two electrodes. The many available types of capacitors are classed according to their dielectric types. Figure 5-1 shows the typical capacitance value ranges by the dielectric types of capacitors. Table 5-1 lists the popular applications and features of the capacitors according to their dielectric classification. Capacitance (C), dissipation factor (D), and equivalent series resistance, ESR, are the parameters generally measured.

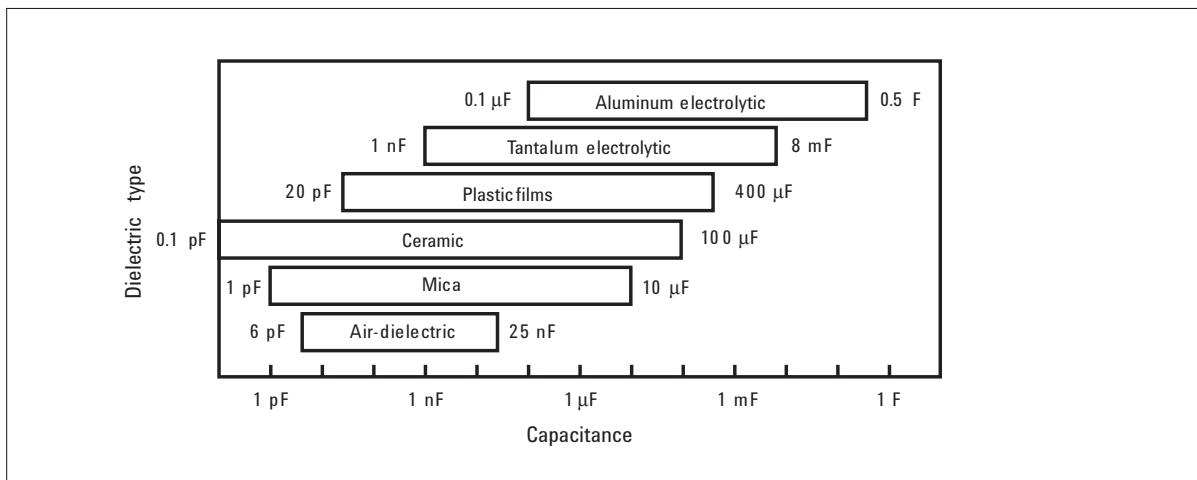


Figure 5-1. Capacitance value by dielectric type

Table 5-1. Capacitor types

Type	Application	Advantage	Disadvantage
Film	<ul style="list-style-type: none"> – Blocking, buffering bypass, coupling, and filtering to medium frequency – Tuning and timing 	<ul style="list-style-type: none"> – Wide range of capacitance and voltage values – High IR, low D, good Q – Stable – Low TC – High voltage 	<ul style="list-style-type: none"> – Medium cost
Mica	<ul style="list-style-type: none"> – Filtering, coupling, and bypassing at high frequencies – Resonant circuit, tuning – High-voltage circuits – Padding of larger capacitors 	<ul style="list-style-type: none"> – Low dielectric losses and good temperature, frequency, and aging characteristics – Low AC loss, high frequency – High IR – Low cost – Extensive test data, reliable 	<ul style="list-style-type: none"> – Low capacitance-to-volume ratio
Ceramic	<ul style="list-style-type: none"> – Bypassing, coupling, and filtering to high frequency 	<ul style="list-style-type: none"> – High capacitance-to-volume ratio – Chip style available – Low D (low k type) – Low cost – Extensive test data, reliable 	<ul style="list-style-type: none"> – Poor temperature coefficients and time stability – Large voltage dependency and susceptible to pressure (high k type)
Tantalum electrolytic	<ul style="list-style-type: none"> – Blocking, bypassing coupling, and filtering in low-frequency circuits, timing, color convergence circuits squib firing, photoflash firing 	<ul style="list-style-type: none"> – High capacitance-to-volume ratio – Good temperature coefficients – Extensive test data 	<ul style="list-style-type: none"> – Voltage limitation – Leakage current – Poor RF characteristics – Medium cost – Failure mode: short
Aluminum electrolytic	<ul style="list-style-type: none"> – Blocking, bypassing coupling, and low frequency filtering Photoflash 	<ul style="list-style-type: none"> – Highest capacitance-to-volume ratio of electrolytics – Highest voltage of electrolytics – Highest capacitance – Lowest cost per CV unit for commercial types – High ripple capability 	<ul style="list-style-type: none"> – Affected by chlorinated hydrocarbons – High leakage current – Requires reforming after period of storage – Poor RF characteristics – Poor reliability – Short life

5.1.1 Parasitics of a capacitor

A typical equivalent circuit for a capacitor is shown in Figure 5-2. In this circuit model, C denotes the main element of the capacitor. R_s and L are the residual resistance and inductance existing in the lead wires and electrodes. R_p is a parasitic resistance which represents the dielectric loss of the dielectric material.

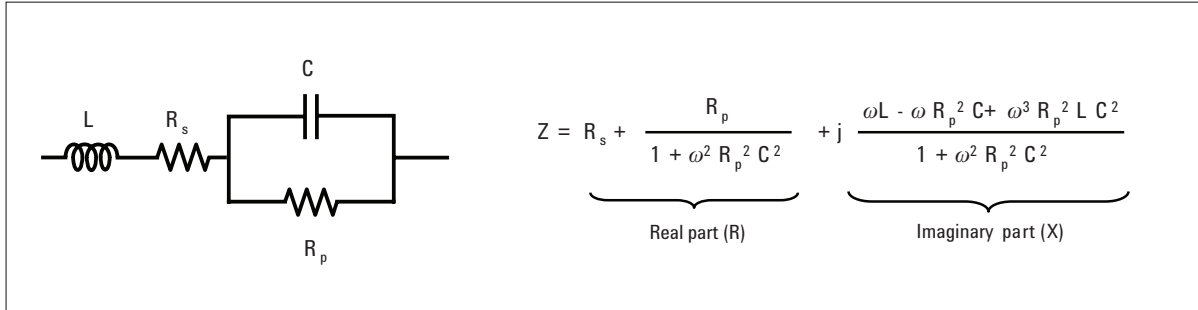


Figure 5-2. Capacitor equivalent circuit

Since real-world capacitors have complicated parasitics, when an impedance measuring instrument measures a capacitor in either the series mode (Cs – D or Cs – Rs) or the parallel mode (Cp – D, Cp – G, or Cp – Rp), the displayed capacitance value, Cs or Cp, is not always equal to the real capacitance value, C, of the capacitor. For example, when the capacitor circuit shown in Figure 5-2 is measured using the Cs – Rs mode, the displayed capacitance value, Cs, is expressed using the complicated equation shown in Figure 5-3. The Cs value is equal to the C value only when the Rp value is sufficiently high (Rp >> 1/ωC) and the reactance of L is negligible (ωL << 1/ωC.) Generally, the effects of L are seen in the higher frequency region where its inductive reactance, ωL, is not negligible. The Rp is usually insignificant and can be disregarded in the cases of high-value capacitors (because Rp >> 1/ωC.) For low-value capacitors, the Rp itself has an extremely high value. Therefore, most capacitors can be represented by using a series C-R-L circuit model as shown in Figure 5-4. Figures 5-5 (a) and (b) show the typical impedance (|Z|_θ) and Cs – D characteristics of ceramic capacitors, respectively. The existence of L can be recognized from the resonance point seen in the higher frequency region.

Note: The relationship between typical capacitor frequency response and equivalent circuit model is explained in Section 1.5.

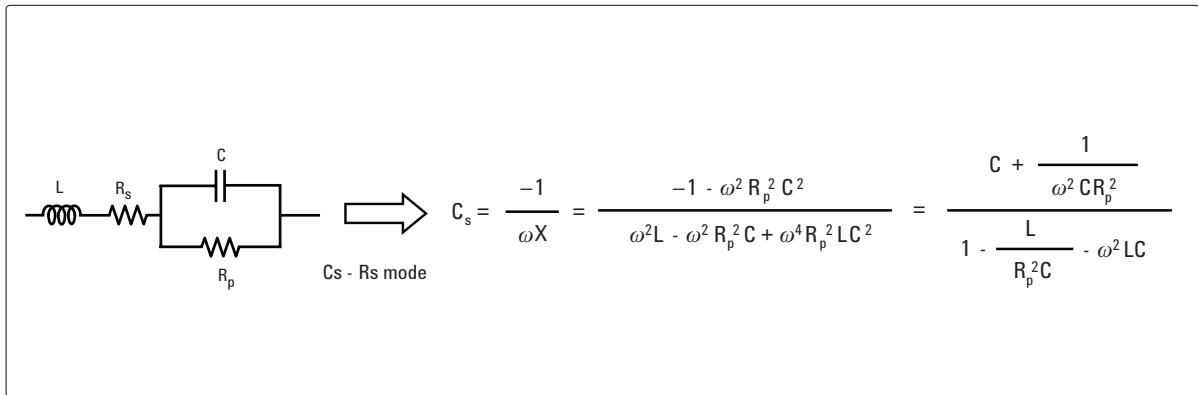


Figure 5-3. Effects of parasitics in actual capacitance measurement

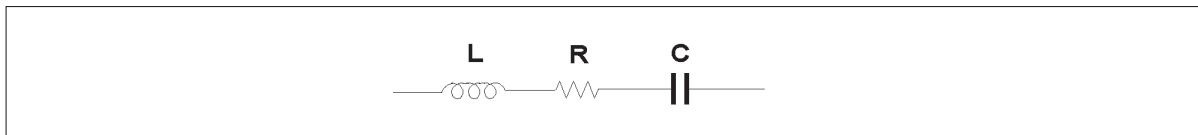


Figure 5-4. Practical capacitor equivalent circuit

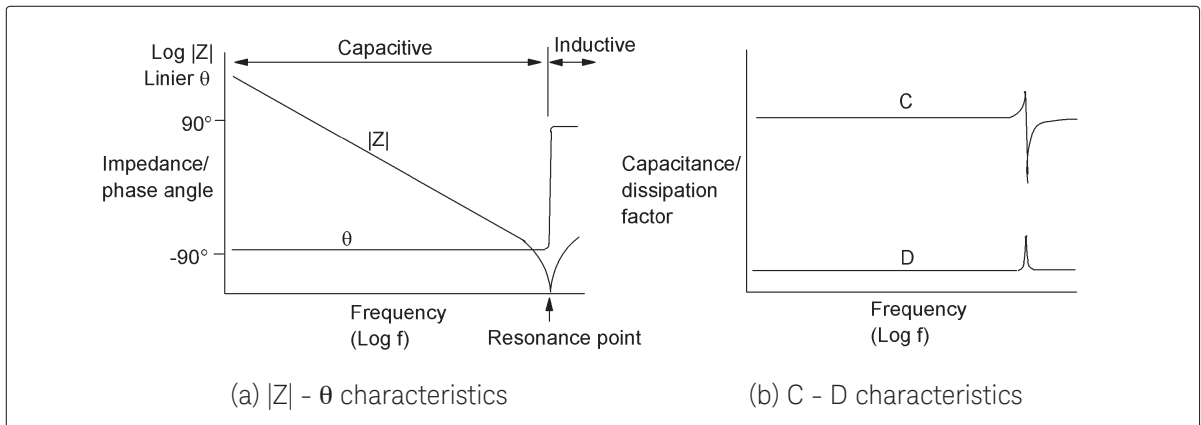


Figure 5-5. Typical capacitor frequency response

5.1.2 Measurement techniques for high/low capacitance

Depending on the capacitance value of the DUT and the measurement frequency, you need to employ suitable measurement techniques, as well as take necessary precautions against different measurement error sources.

High-value capacitance measurement

The high-value capacitance measurement is categorized in the low impedance measurement. Therefore, contact resistance and residual impedance in the test fixture and cables must be minimized. Use a 4T, 5T, or 4TP configuration to interconnect the DUT with the measurement instrument. When the 4T or 5T configuration is used, the effects of electromagnetic field coupling due to a high test signal current flow through the current leads should be taken into considerations. To minimize the coupling, twist the current leads together and the potential leads together, as shown in Figure 5-6. Form a right angle (90°) between the current leads and potential leads connected to DUT terminals.

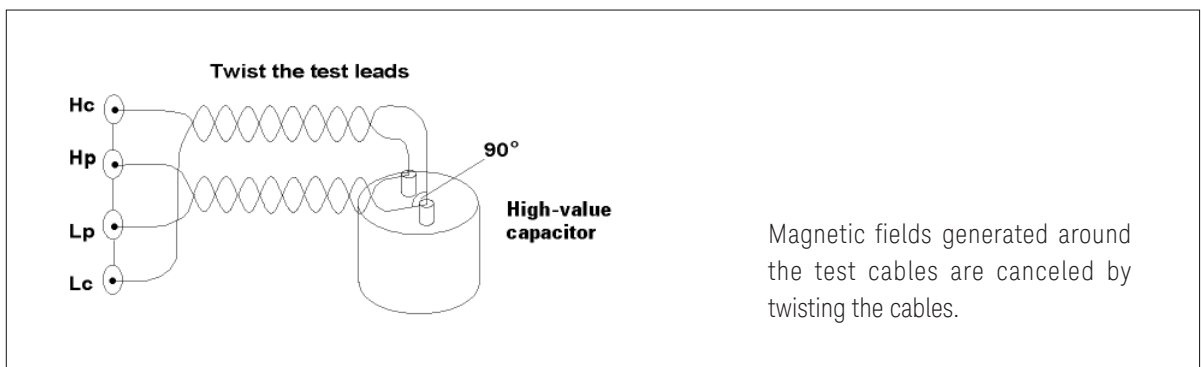


Figure 5-6. High-value capacitor measurement

Also, for an accurate measurement, open/short compensation should be properly performed. During the open/short measurements (in the 4T or 5T configuration), maintain the same distance between the test cables as when the DUT will be measured. For electrolytic capacitors, which require a DC bias voltage to be applied, the open/short compensation should be performed with the DC bias function set to ON (0 V bias output.)

The component dependency factors discussed in Section 1 should be taken into account, especially when measuring high-value ceramic capacitors. The high-value ceramic capacitors exhibit a large dependence on frequency, test signal voltage (AC), DC bias, temperature, and time.

Low-value capacitance measurement

The low-value capacitance measurement is categorized in the high impedance measurement. Stray capacitance between the contact electrodes of a test fixture is a significant error factor compared to the residual impedance. To make interconnections with the DUT, use a 3T (shielded 2T), 5T (shielded 4T), or 4TP configuration. Proper guarding techniques and the open/short compensation can minimize the effects of stray capacitance (refer to Section 3.4.) Figure 5-7 shows the typical procedure for performing the open/short compensation when measuring SMD (chip-type) capacitors with the Keysight 16034E/G test fixtures.

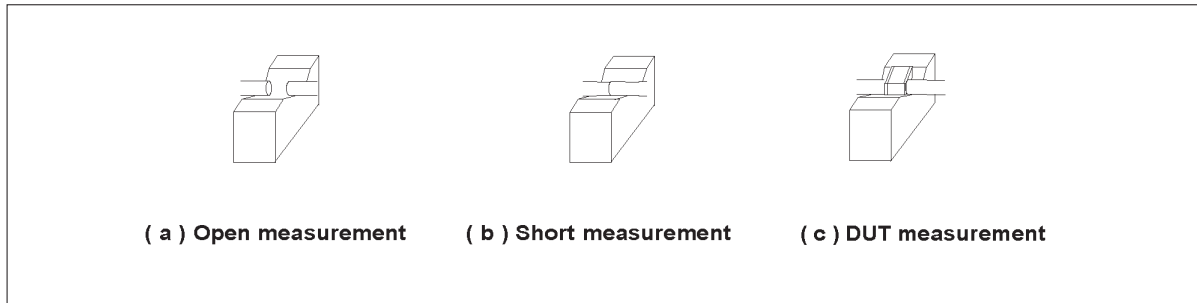


Figure 5-7. Low-value chip capacitor measurement

Other than capacitance, important capacitor parameters are the dissipation factor, D , and the ESR. Special precautions must be taken in the low D or low ESR measurements. Contact resistance and residual impedance in the test fixture and cables will affect the measurement results even when the 4T configuration is used (refer to Section 4.)

DC biased capacitance measurement

The DC biased capacitance measurement can be performed using the internal DC bias function of an impedance measuring instrument, or an external bias fixture for applying a bias voltage from an external DC source. When the DC bias voltage is changed, a bias settling time needs to be taken until the capacitor is charged by the applied bias voltage. The required bias settling time increases in proportion to the capacitance of the DUT. Accordingly, to perform an accurate bias sweep measurement for a high-value capacitor, it is necessary to insert a delay time between the step-up (or the step-down) of bias voltage and measurement trigger for each sweep measurement point. The required bias settling time can be obtained from DC bias performance data of the instrument or bias fixture used.

5.1.3 Causes of negative D problem

When measuring the dissipation factor (D) of a low loss capacitor, the impedance measuring instrument may sometimes display a negative D value despite the fact that the real dissipation factor must be a positive value. A negative D measurement value arises from a measurement error for a small resistance component of the measured impedance. In this section, we discuss the causes of negative D and the methods for minimizing the measurement errors that lead to the negative D problem. Five typical causes of negative D problem are:

- Instrument inaccuracy
- Contact resistance in the 4TP or 5T configuration
- Improper short compensation
- Improper cable length correction
- Complicated residuals

Note: The following discussion also applies to a negative Q problem because the Q factor is the reciprocal of D.

D measurement error due to instrument inaccuracy

If a DUT has a low D value compared with the D measurement accuracy (allowable D measurement error) of the instrument, a measured dissipation factor may become a negative value. Figure 5-8 shows how the D measurement accuracy of instrument impacts a negative D value. For example, when D measurement accuracy (of instrument A) is ± 0.001 for a low-loss capacitor that has a dissipation factor of 0.0008, the impedance measurement error is represented by a dotted circle on the vector plane as shown in Figure 5-8. The shaded area of the dotted circle exists on the left side of reactance axis (X axis.) This shaded area represents the negative D area in which the resistance component of the measured impedance is a negative value. The allowable D value range is from -0.0002 to 0.0018 . In this case, there is possibility that a negative D value is displayed. If the D measurement accuracy (of instrument B) is ± 0.0005 , the measured impedance vector is within the solid circle as shown in Figure 5-8. The negative D value is not displayed because the allowable D value range is from 0.0003 to 0.0013 . Accordingly, an impedance measuring instrument with the best possible accuracy is required for avoiding negative D display in low dissipation factor measurements.

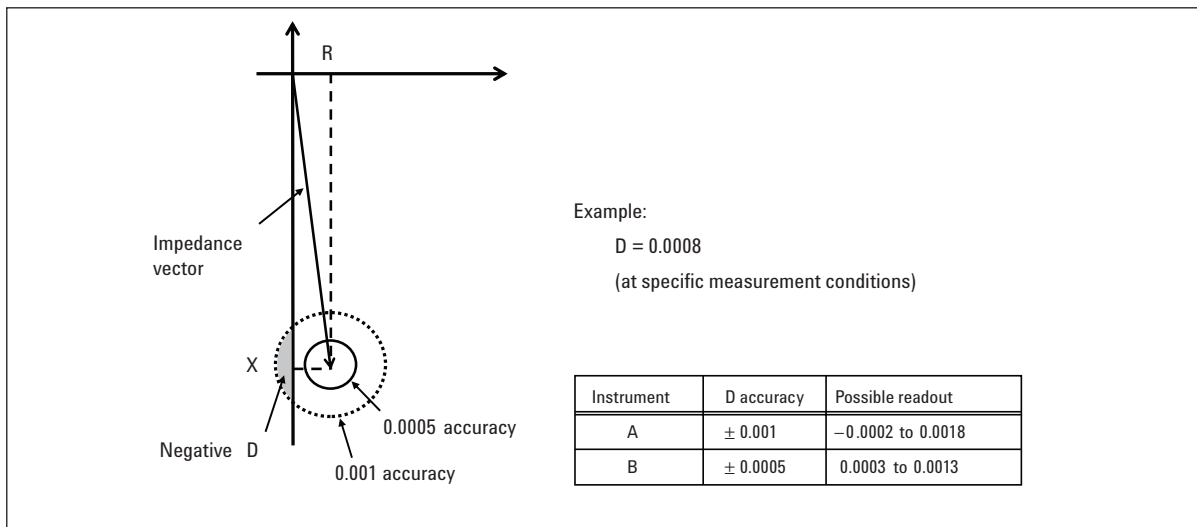


Figure 5-8. Negative D measurement value due to measurement inaccuracy

Contact resistance

As described in Section 4.4, contact resistance between the DUT's electrodes and the contact electrodes of the test fixture causes D measurement error. While the contact resistance of the 2T test fixture directly adds to the measured impedance as a positive D error, the contact resistance at the Hp and Lc electrodes of a 4T test fixture cause a negative D error (see Figure 4-10.) When a capacitor that has a very low D is measured using a 4T test fixture, a negative D value is displayed depending on the magnitude of the D measurement error due to a contact resistance.

Improper short compensation

When short compensation is performed based on an improper short measurement value, a negative D value may be displayed. Major causes of an improper short measurement are a contact resistance at the test fixture's electrodes and a residual resistance of the shorting bar. As described in Section 4.3, the resistance (R_s) and reactance (X_s) values obtained by short measurement are stored in the instrument and removed from the measured impedance of the DUT by performing the short compensation. If the R_s value is greater than the resistance component (R_{xm}) of the DUT's impedance, the corrected resistance ($R_{xm} - R_s$) becomes a negative value and, as a result, a negative D value is displayed. To avoid this problem, clean the test fixture's electrodes to minimize the contact resistance and use a shorting bar with the lowest possible residual resistance.

Improper cable length correction

When cable length correction is not properly performed for the test cables used, a negative D value may be displayed at high frequencies because a phase angle measurement error is caused by the cables. The error increases in proportion to the square of the measurement frequency. After the cable length correction is performed, a small phase error may remain and cause a negative D value because the characteristics of test cables are slightly different for the respective cables. The open/short/load compensation can minimize the measurement error due to the differences between the cables.

Complicated residuals

Using a long cable, a component scanner, or a component handler has the propensity to cause a negative D display due to complicated residuals. When complex residual impedance and stray admittance exist in the connection circuit between the DUT and the calibration plane of the impedance measuring instrument, the characteristics of the connection circuit do not match the open/short compensation circuit model (see Figure 4-4.) Since the open/short compensation cannot effectively remove the measurement error due to the complex residuals and strays, a D measurement error causes a negative D display. The open/short/load compensation is an effective method for eliminating measurement errors caused by complicated residuals.

5.2 Inductor measurement

5.2.1 Parasitics of an inductor

An inductor consists of wire wound around a core and is characterized by the core material used. Air is the simplest core material for making inductors, but for volumetric efficiency of the inductor, magnetic materials such as iron, permalloy, and ferrites are commonly used. A typical equivalent circuit for an inductor is shown in Figure 5-9 (a). In this figure, R_p represents the magnetic loss (which is called iron loss) of the inductor core, and R_s represents the copper loss (resistance) of the wire. C is the distributed capacitance between the turns of wire. For small inductors the equivalent circuit shown in Figure 5-9 (b) can be used. This is because the value of L is small and the stray capacitance between the lead wires (or between the electrodes) becomes a significant factor.

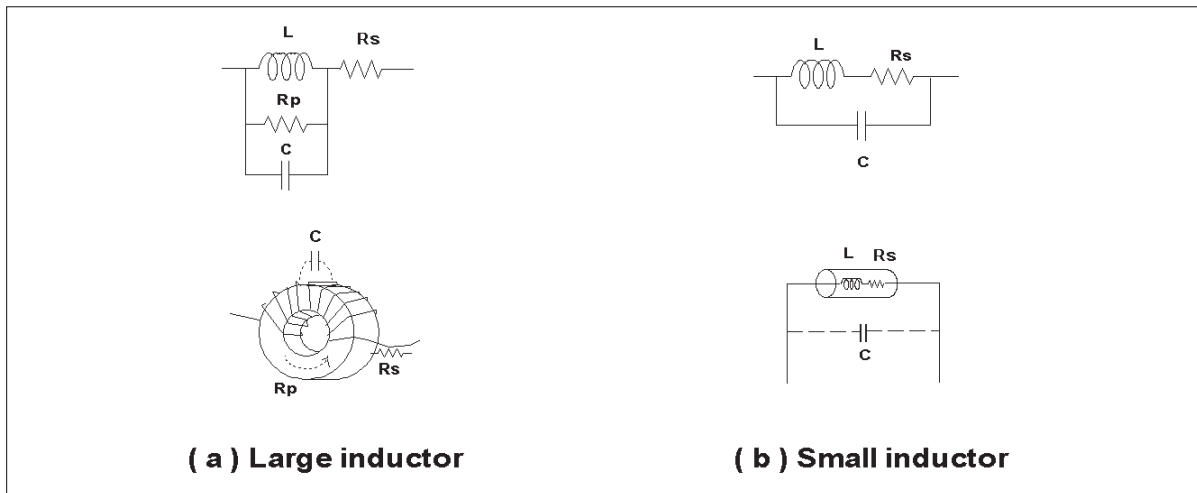


Figure 5-9. Inductor equivalent circuit

Generally, inductors have many parasitics resulting from the complexity of the structure (coil) and the property of the magnetic core materials. Since a complex equivalent circuit is required for representing the characteristics, which include the effects of many parasitics, a simplified model for approximation is used for practical applications. In this section, we discuss the frequency response of a low-value inductor, which is represented by equivalent circuit model shown in Figure 5-9 (b). This model will fit for many SMD (chip) type RF inductors.

When the inductor circuit shown in Figure 5-10 is measured using the L_s - R_s mode, the measured L_s value is expressed by the equation shown in Figure 5-11. The measured L_s value is equal to the L value only when the inductor has low R_s value ($R_s \ll \omega L$) and low C value ($1/\omega C \gg \omega L$). Typical frequency characteristics of impedance ($|Z|$, θ) for a low-value inductor are shown in Figure 5-12 (a). Since the reactance (ωL) decreases at lower frequencies, the minimum impedance is determined by the resistance (R_s) of winding. The stray capacitance C_p is the prime cause of the inductor frequency response at high frequencies. The existence of C_p can be recognized from the resonance point, SRF, in the higher frequency region. At the SRF, the inductor exhibits maximum impedance because of parallel resonance ($\omega L = 1/\omega C_p$) due to the C_p . After the resonance frequency, the phase angle of impedance is a negative value around -90° because the capacitive reactance of C_p is dominant. The inductor frequency response in L_s - R_s measurement mode is shown in Figure 5-12 (b). The measured inductance (L_m) rapidly increases as the frequency approaches the SRF because of the effect of resonance. The maximum L_m value becomes greater as the device has a higher Q factor. At frequencies above the SRF, a negative inductance value is displayed because the L_m value is calculated from a capacitive reactance vector, which is opposite to inductive vector.

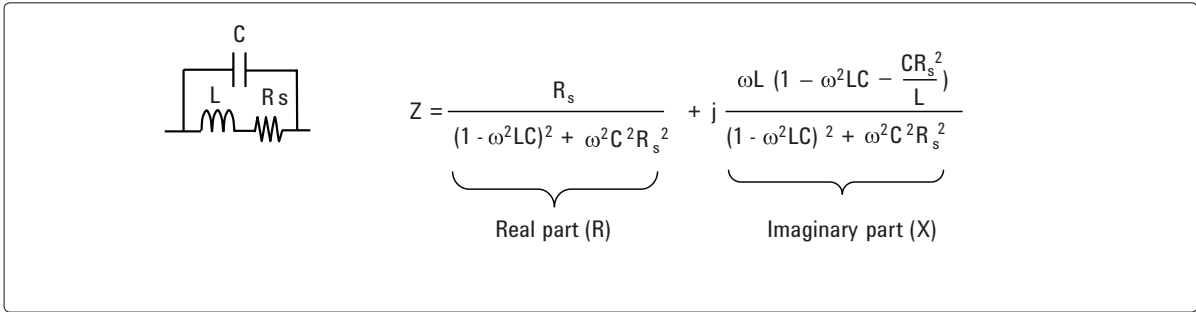


Figure 5-10. Inductor equivalent circuit

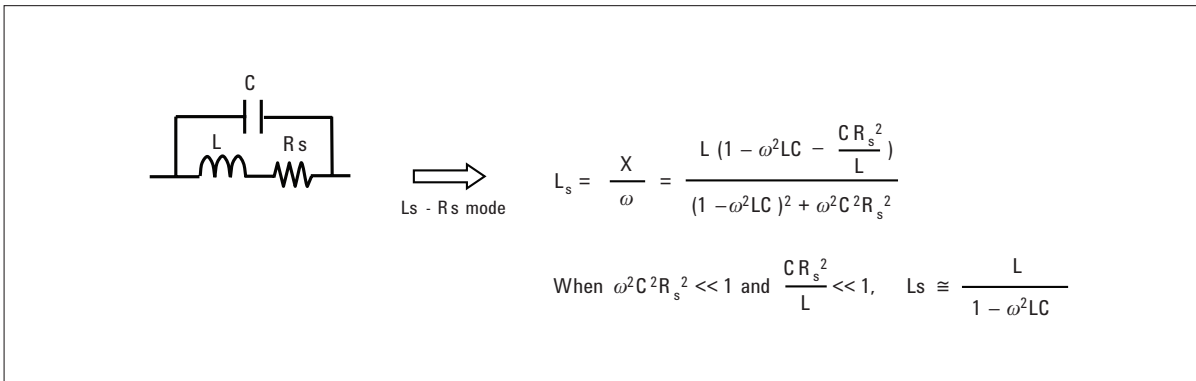


Figure 5-11. Effects of parasitics in actual inductor measurement

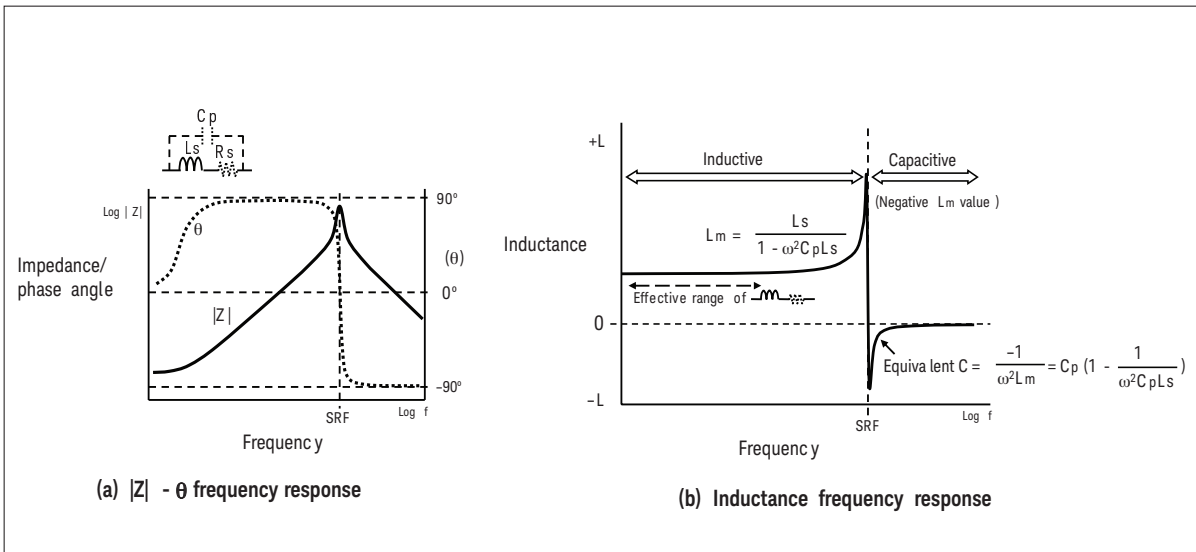


Figure 5-12. Typical inductor frequency response

5.2.2 Causes of measurement discrepancies for inductors

Inductance measurement sometimes gives different results when a DUT is measured using different instruments. There are some factors of measurement discrepancies as described below:

Test signal current

Inductors with a magnetic core exhibit a test signal current dependency due to the nonlinear magnetization characteristics of the core material as shown in Figure 5-13 (a). The level of test signal current depends on the impedance measurement instrument because many of the instruments output a voltage-driven test signal. Even when two different instruments are set to output the same test signal (OSC) voltage, their output currents are different if their source resistance, R_s , is not the same as shown in Figure 5-13 (b).

To avoid the measurement discrepancies, the OSC level should be adjusted for a defined test current by using the auto level control (ALC) function or by determining the appropriate test voltage setting from the equation shown in Figure 5-13 (b).

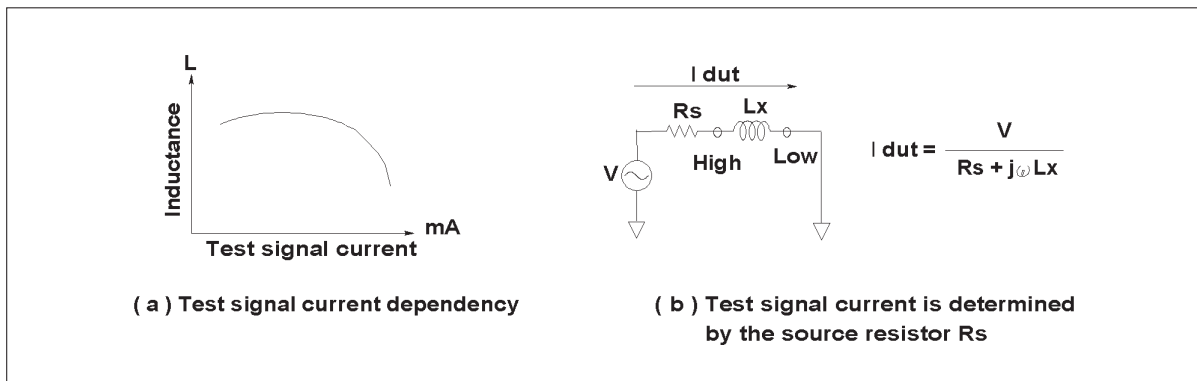


Figure 5-13. Inductor test signal current

Test fixture used

When a metal object is located close to an inductor, leakage flux from the inductor will induce eddy currents in the metal object. The magnitudes of the induced eddy currents are dependent on the dimensions and physical geometry of metal object, as shown in Figure 5-14 (a), causing differences in the measured values. The eddy current effect is especially important for measuring open-flux-path inductors. Figure 5-14 (b) shows an example of the difference in $L_s - Q$ measurement values due to the eddy current effect. When a 40 mm x 40 mm square and 1.0 mm thick brass plate is placed closely to a 100 μ H RF inductor, the measured $L_s - Q$ values decrease according to the approach of the plate from # (sufficient distance) to 10 mm and 1 mm. The eddy current effect due to the leakage flux causes discrepancies in measurement results between different types of test fixtures because the test fixtures are also metal objects. To obtain consistent measurement results, it is necessary to define the test fixture used for inductor measurements. Additionally, the DUT should be connected at the same position of the same test fixture.

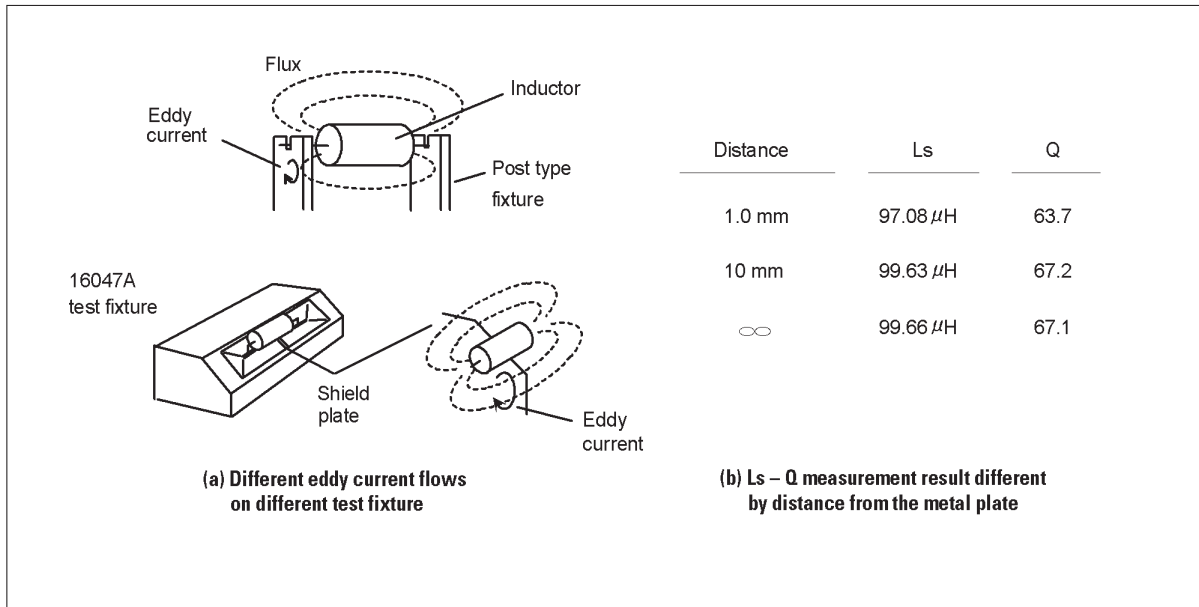


Figure 5-14. Test fixture effects

Q measurement accuracy

Generally, the Q-factor measurement accuracy in the impedance measurement is not high enough to measure the high Q device. Figure 5-15 shows the relationship of Q accuracy and measured Q values. Because the Q value is the reciprocal of D, ($Q = 1/D$), the Q accuracy is related to the specified D measurement accuracy as shown in Figure 5-15. The Q measurement error increases with the DUT's Q value and, therefore, the practically measurable Q range is limited by the allowable Q measurement error. (For example, if the allowable Q error is ten percent and if the instrument's D accuracy is ± 0.001 , the maximum measurable Q value is 90.9. (See Appendix E for the Q measurement accuracy calculation equation.)

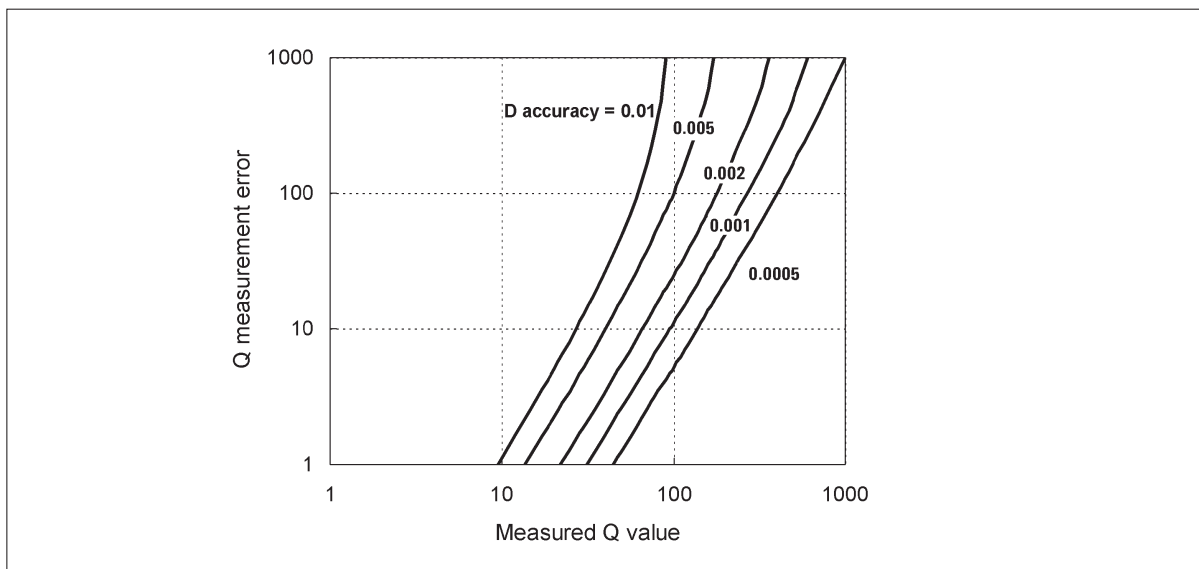


Figure 5-15. Q measurement accuracy

Figure 5-16 shows the measured vector of a high Q inductor. Except for the resonant method, the impedance measurement instrument calculates the Q value by $Q = X/R$. The impedance measurement error is represented by a small circle enclosing the error vector (Δ). The R value of a high Q (low loss) inductor is very small relative to the X value. Small changes in R results in large Q value changes ($Q = X/R$). Therefore, error in the R measurement can cause significant error in the Q factor, especially in high Q devices. A negative Q problem also arises from the Q (D) measurement error as described in Section 5.1.3.

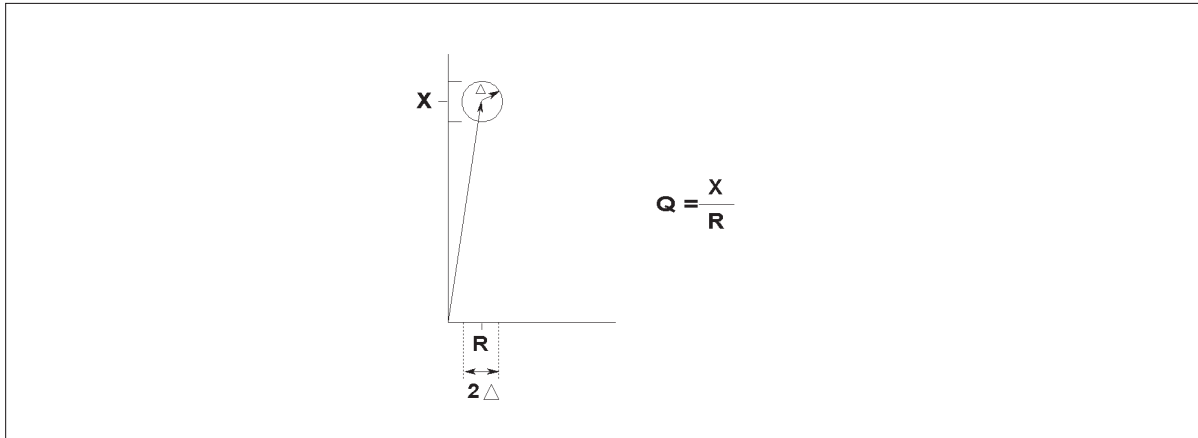


Figure 5-16. Q measurement error

The following methods deliver improvement to Q measurement accuracy:

- (1) Use the instrument with better accuracy
- (2) Perform optimum compensation for residual resistance and cable length
- (3) Use an equivalent circuit analysis function and calculate the Q value from the equivalent circuit parameter values obtained for the DUT (refer to Section 5.15.)

Furthermore, the following phenomena may occur when a cored inductor is measured using an auto-balancing bridge type instrument.

When a high level test signal is applied to an inductor, measurement may be impossible for a certain frequency range. This is because the nonlinearity of the core material causes harmonic distortion of the test signal current, which hinders measurements. If excessive distortion current flows into the Lpot terminal of the instrument, it causes the bridge unbalance status (see Figure 5-17 (a).) To reduce the effects of core material nonlinearity, decrease the test signal level. If the measurement frequency is fixed, it is possible to reduce the distortion current flow into the Lpot terminal by connecting a low-pass filter (LPF) at the Lpot terminal as shown in Figure 5-17 (b).

When a high level DC bias current is applied to an inductor, measurement may be impossible for a certain frequency range. This is because test signal distortion is caused by the magnetic saturation of the inductor core under the applied bias magnetic field. To reduce the effects of core material nonlinearity, take the same precautions as those for measurement at a high test signal level.

When a test cable is used to measure low-value inductors, measurement may be impossible for certain values of inductance at higher frequencies. This is caused by resonance resulting from the DUT's inductance and the capacitance of Hp and Hc cables. In this case, the capacitance of the cables should be changed so that the resonant frequency shifts to a much higher frequency than the maximum test frequency required. Reduce the length of the Hc and Hp cables or use another type of cable to decrease the capacitance.

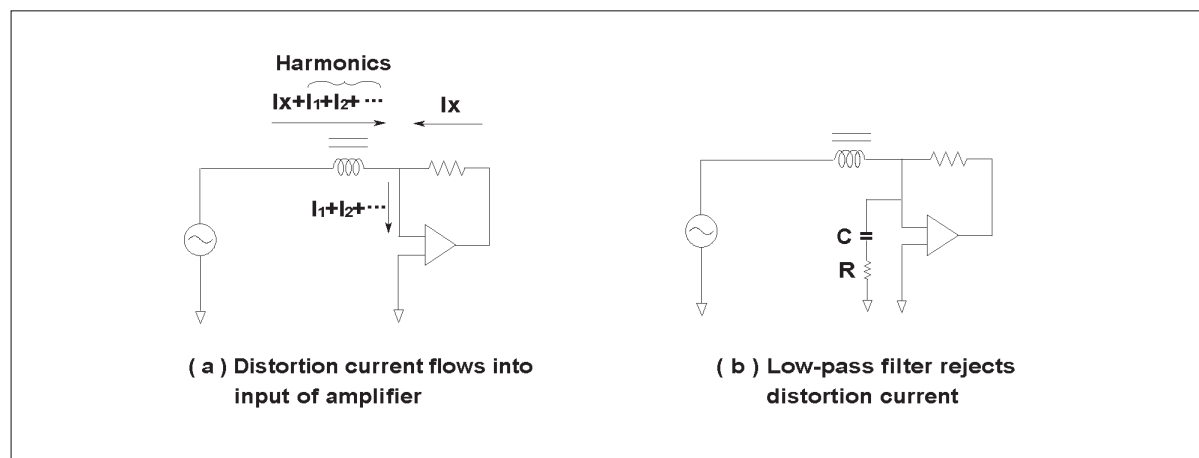


Figure 5-17. Harmonic distortion caused by inductors

5.3 Transformer measurement

A transformer is one end-product of an inductor so, the measurement techniques are the same as those used for inductor measurement. Figure 5-18 shows a schematic with the key measurement parameters of a transformer. This section describes how to measure these parameters, including L, C, R, and M.

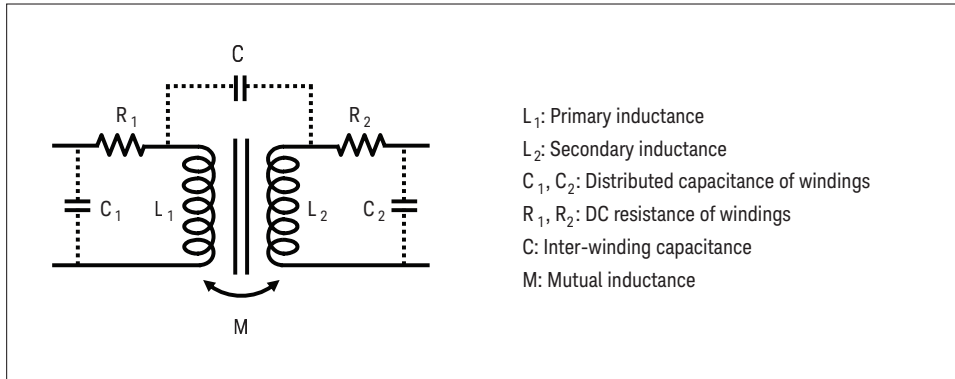


Figure 5-18. Transformer parameters

5.3.1 Primary inductance (L_1) and secondary inductance (L_2)

L_1 and L_2 can be measured directly by connecting the instrument as shown in Figure 5-19. All other windings should be left open. Note that the inductance measurement result includes the effects of capacitance. If the equivalent circuit analysis function of Keysight's impedance analyzer is used, the individual values for inductance, resistance, and capacitance can be obtained.

Leakage inductance is a self-inductance due to imperfect coupling of the transformer windings and resultant creation of leakage flux. Obtain leakage inductance by shorting the secondary with the lowest possible impedance and measuring the inductance of the primary as shown in Figure 5-20.

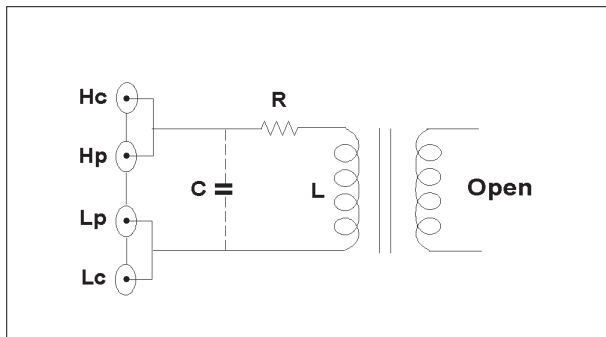


Figure 5-19. Primary inductance measurement

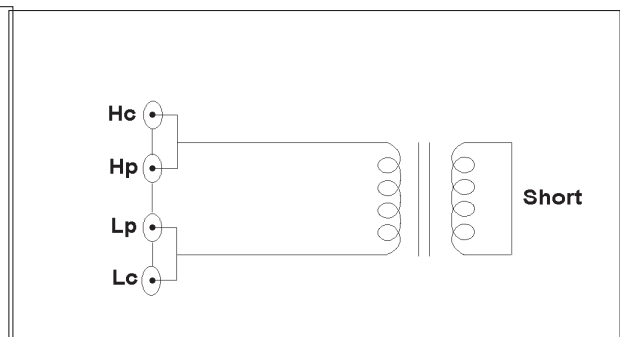


Figure 5-20. Leakage inductance measurement

5.3.2 Inter-winding capacitance (C)

The inter-winding capacitance between the primary and the secondary is measured by connecting one side of each winding to the instrument as shown in Figure 5-21.

5.3.3 Mutual inductance (M)

Mutual inductance (M) can be obtained by using either of two measurement methods:

(1) The mutual inductance can be derived from the measured inductance in the series aiding and the series opposing configurations (see Figure 5-22 (a).) Since the combined inductance (L_a) in the series aiding connection is $L_a = L_1 + L_2 + 2M$ and that L_o in the series opposing connection is $L_o = L_1 + L_2 - 2M$, the mutual inductance is calculated as $M = (L_a - L_o)/4$.

(2) By connecting the transformer windings as shown in Figure 5-22 (b), the mutual inductance value is directly obtained from inductance measurement. When test current (I) flows through the primary winding, the secondary voltage is given by $V = j\omega M \times I$. Therefore, the mutual inductance can be calculated from the ratio between the secondary voltage (V) and the primary current (I .) However, the applicable frequency range of both measurement techniques is limited by the type and the parameter values of the transformer being measured. These methods assume that the stray capacitance effect, including the distributed capacitance of windings, inter-winding capacitance, and test lead capacitance, is sufficiently small. To minimize the cable capacitance effect for the method shown in Figure 5-22 (b), the H_p test lead length should be made as short as possible. It is recommend to use both techniques and to cross-check the results.

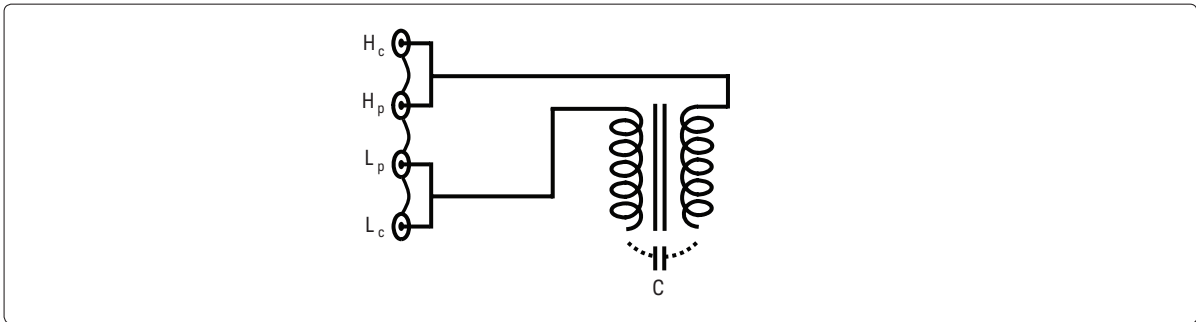


Figure 5-21. Inter-winding capacitance measurement

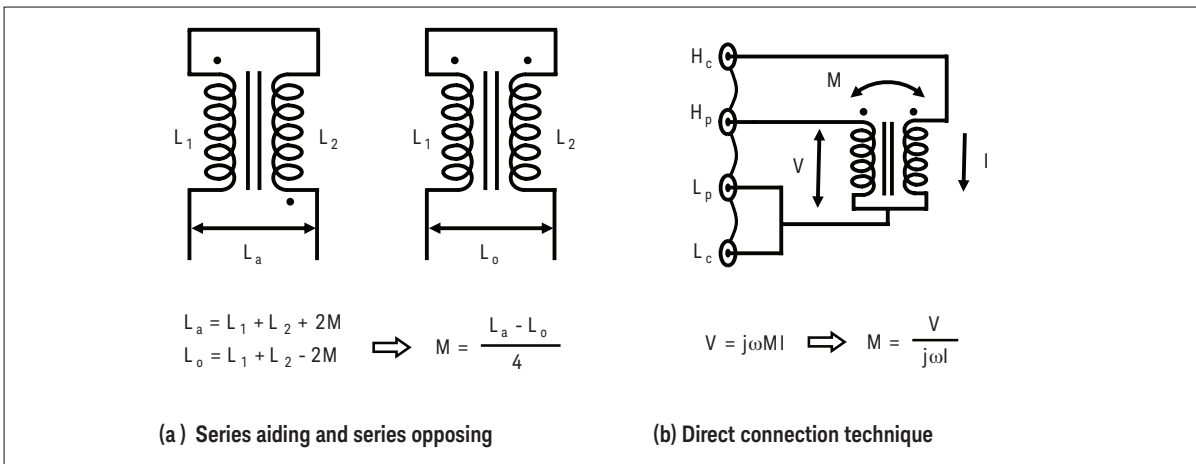


Figure 5-22. Mutual inductance measurement

5.3.4 Turns ratio (N)

Turns ratio (N) measurement technique, which can be used with general impedance measuring instruments, approximates the turns ratio (N:1) by connecting a resistor to the secondary as shown in Figure 5-23 (a). From the impedance value measured at the primary, the approximate turns ratio can then be calculated. Direct turns ratio measurement can be made with a network analyzer or built-in transformer measurement function (option) of the Keysight 4263B LCR meter. The turns ratio can be determined from the voltage ratio measurements for the primary and the secondary, as shown in Figure 5-23 (b). The voltmeter (V_2) should have high input impedance to avoid affecting the secondary voltage. The properties of magnetic core and the effects of stray capacitance limit the applicable frequency range of the turns ratio measurement methods.

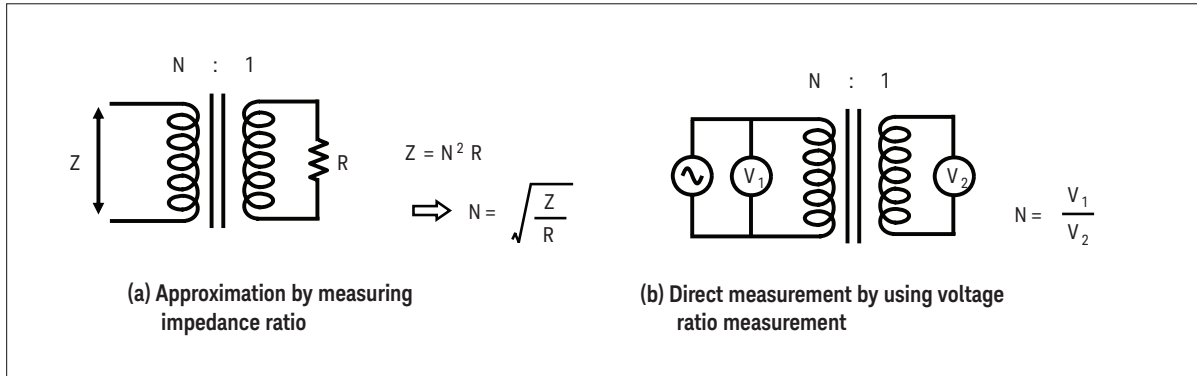


Figure 5-23. Turns ratio measurement

The 4263B's transformer measurement function enables the measurement of the N, M, L_1 , and the DC resistance of the primary by changing measurement circuit connections with an internal switch. Figure 5-24 shows a simplified schematic block diagram for the transformer measurement function of the 4263B. A test signal is applied to the primary and L_1 is calculated from the measured values of V_1 and I_1 . M is calculated from V_2 and I_1 . N is obtained from the ratio of V_1 and V_2 . In the DC resistance measurement, the applied voltage at the Hcur terminal is DC. The DC resistance value is calculated from measured DC voltage V_1 and current I_1 .

Using the Keysight 16060A transformer test fixture with the 4263B permits the L_2 and DC resistance measurement for the secondary, along with all the parameters for the primary. The circuit connection diagram of the 16060A is shown in Figure 5-25.

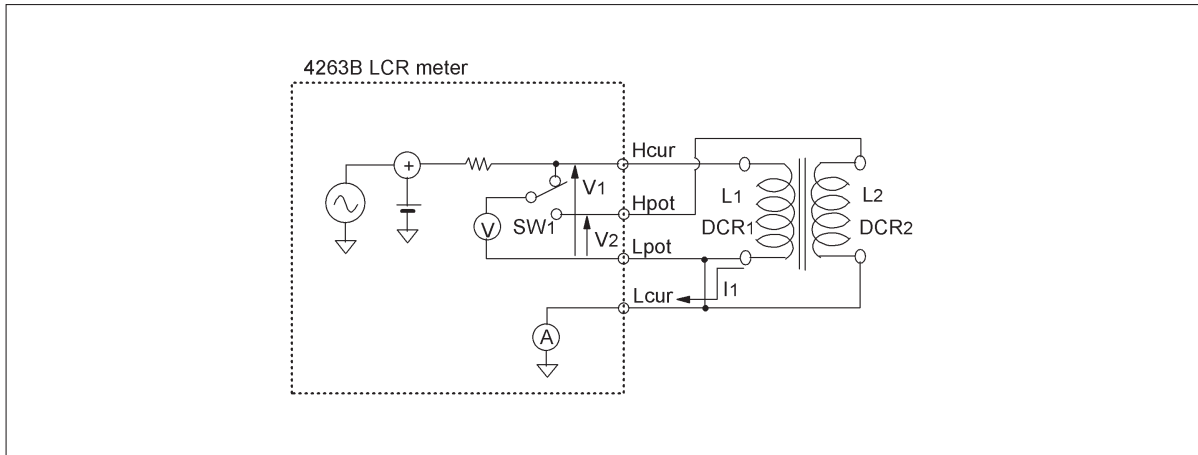


Figure 5-24. 4263B transformer measurement function schematic block diagram

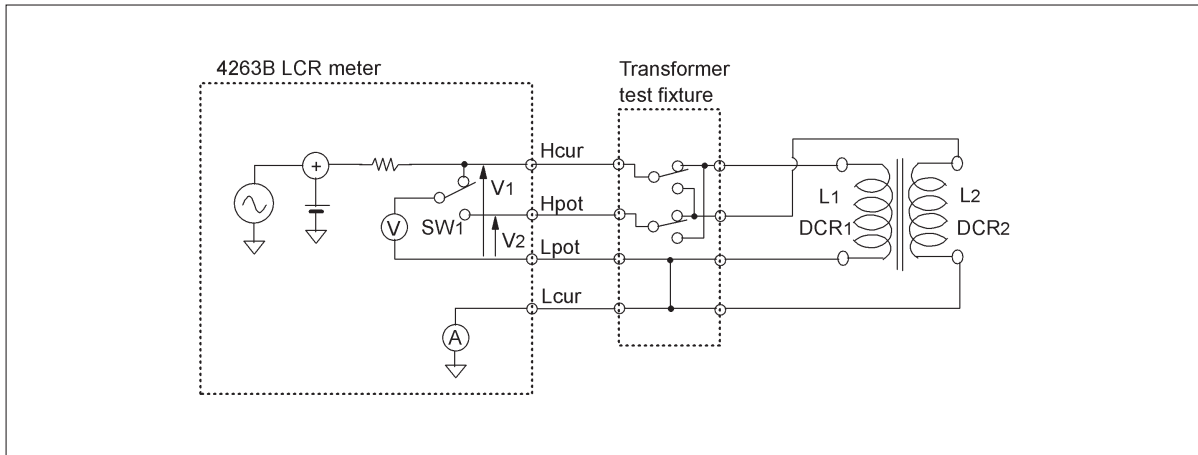


Figure 5-25. 16060A circuit connection diagram

5.4 Diode measurement

The junction capacitance of a switching diode determines its switching speed and is dependent on the reverse DC voltage applied to it. An internal bias source of the measurement instrument is used to reverse-bias the diode. The junction capacitance is measured at the same time. Figure 5-26 shows the measurement setup.

For variable capacitance diodes (varactor diode) that use capacitance-bias characteristics, it is important to measure capacitance accurately while applying an accurate DC bias voltage. Figure 5-27 shows an example of measuring the C-V characteristics of a varactor diode. Use a low test signal level (typically 20 mV rms) to precisely trace the relationship of the capacitance to the DC bias voltage.

The varactors for high frequency applications require Q factor or ESR measurement along with capacitance at a frequency above 100 MHz. The RF I-V measurement instrument is adequate for this measurement. It is possible to measure Q or ESR with the same setup as for the C-V measurement by merely selecting the desired parameter.

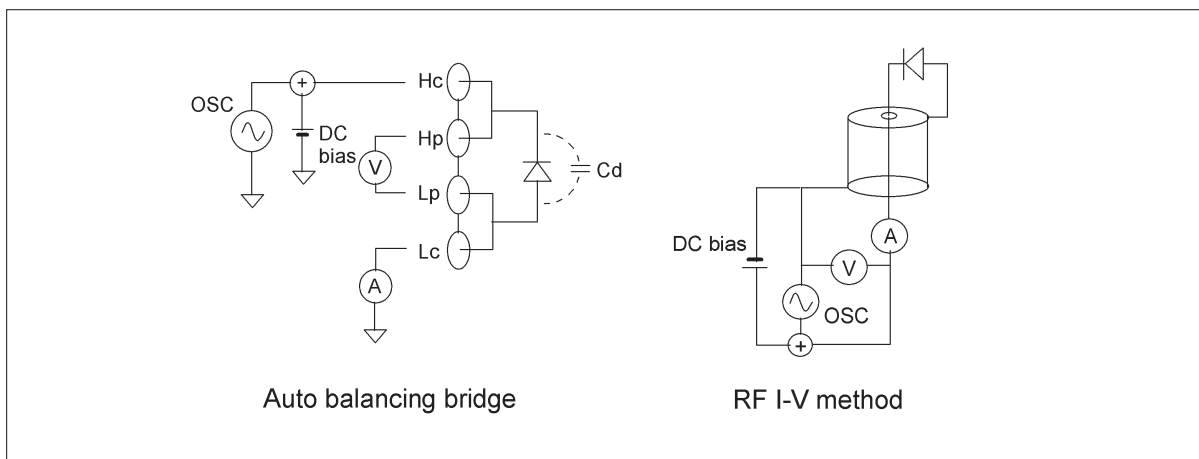


Figure 5-26. Reverse biased diode measurement setup

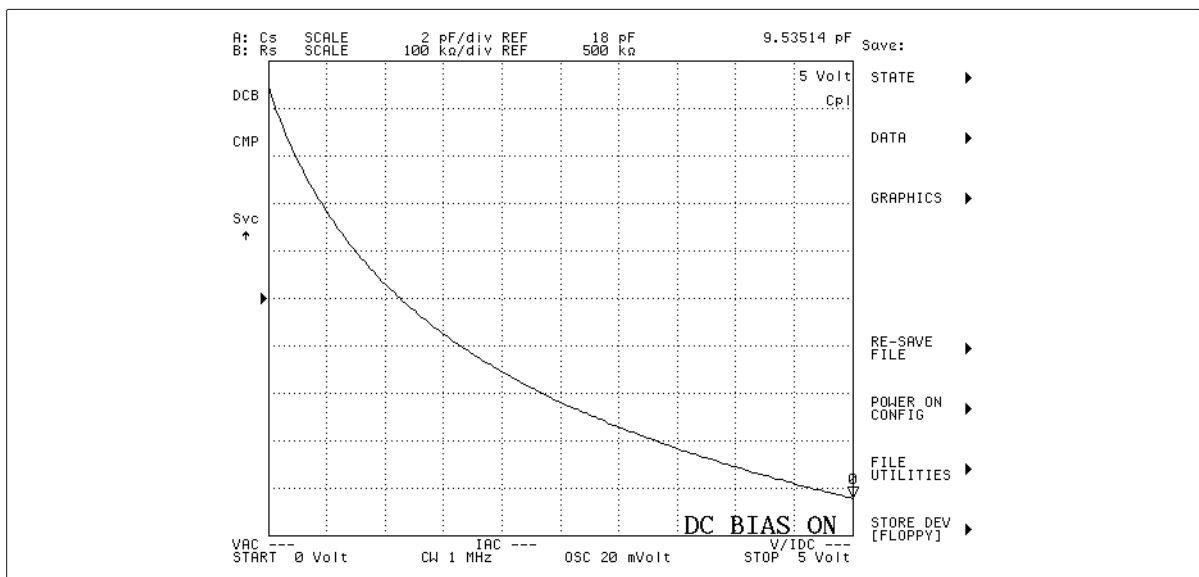


Figure 5-27. Varactor C-V characteristics

5.5 MOS FET measurement

Evaluating the capacitances between the source, drain, and gate of an MOS FET is important in the design of high frequency and switching circuits. Generally, these capacitances are measured while a variable DC voltage source is connected to the drain terminal referenced to the source, and the gate is held at zero DC potential (Figure 5-28). When an instrument is equipped with a guard terminal and an internal DC bias source, capacitances C_{ds} , C_{gd} , and C_{gs} can be measured individually. Figures 5-29 (a) through (c) show the connection diagrams for an instrument's High, Low, and Guard terminals. The guard is the outer conductors of BNC connectors of the UNKNOWN terminals.

The E4980A, with Option E4980A-001 has an independent DC source in addition to an internal DC bias and allows the C_{gs} measurement set up to be simplified as shown in Figure 5-29 (d).

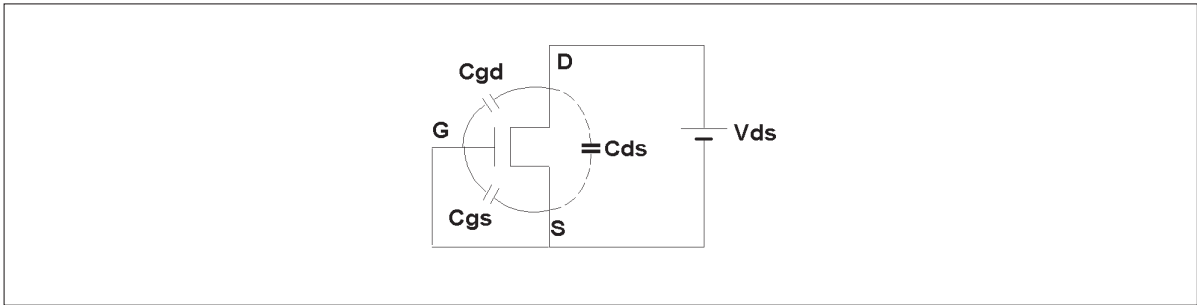


Figure 5-28. Capacitance of MOS FET

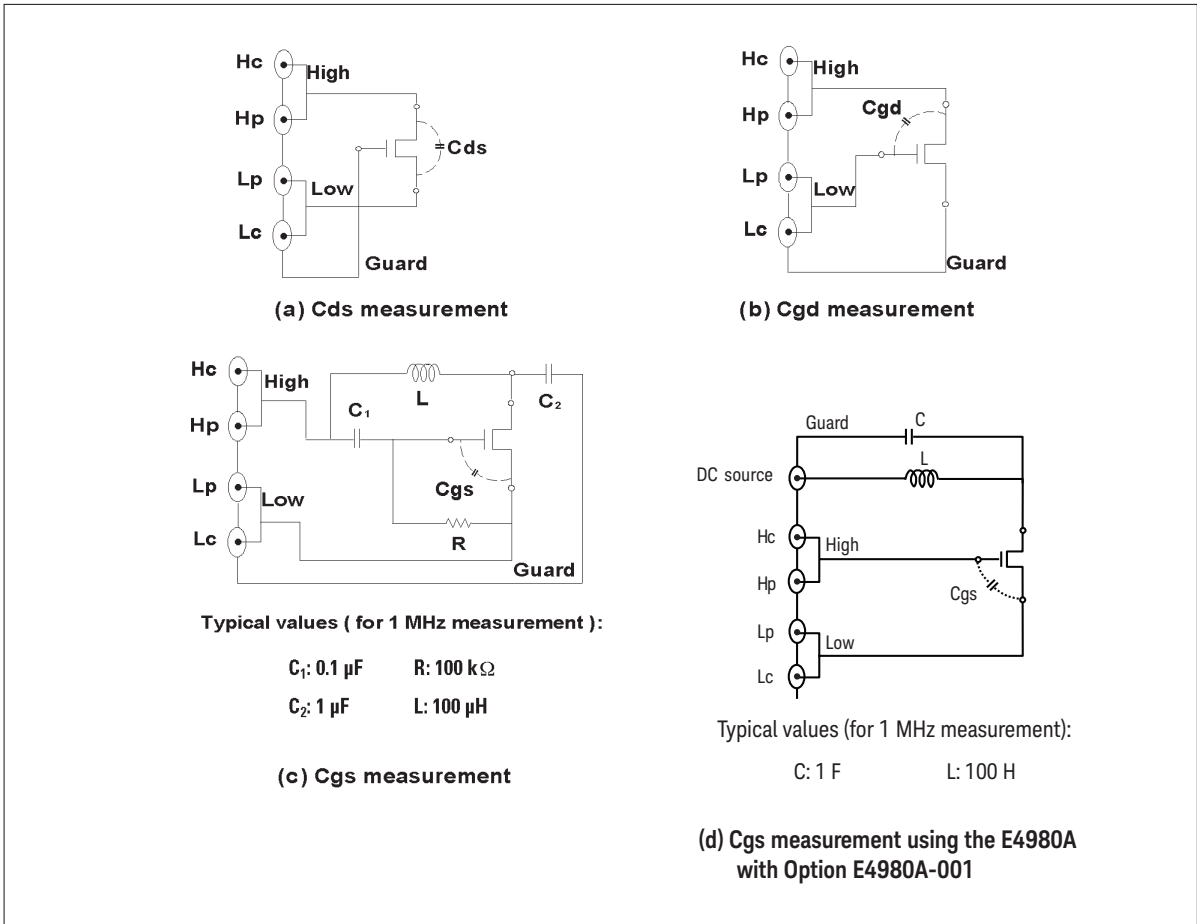


Figure 5-29. MOS capacitance measurement

5.6 Silicon wafer C-V measurement

The C-V (capacitance versus DC bias voltage) characteristic of a MOS structure is an important measurement parameter for evaluating silicon wafers. To evaluate the capacitance that varies with applied DC bias voltage, capacitance is measured at a low AC signal level while sweeping a number of bias voltage points. Because the device usually exhibits a low capacitance (typically in the low picofarads), the instrument must be able to measure low capacitance accurately with a high resolution at a low test signal level. Precise bias voltage output is also required for accurate C-V measurement. Typical C-V measurement conditions are listed in Table 5-2. Auto-balancing bridge instruments are usually employed to satisfy the required performance.

Figures 5-30 and 5-31 show measurement setup examples using the auto-balancing bridge instrument (Keysight 4294A, E4980A, etc.) with a wafer prober station. Since the Low terminal of the auto-balancing bridge instrument is sensitive to incoming noise, it is important that the Low terminal not be connected to the substrate that is electrically connected to the prober's noisy ground. If the wafer chuck (stage) of the prober is isolated from the ground and effectively guarded, the shielding conductor of the 4TP cable can be connected to the prober's guard terminal to minimize stray capacitance around the probes.

When a device with low resistivity is measured, applied DC voltage decreases due to DC leakage current through the device, and this may cause C-V measurement error. Using the DC bias auto level control (ALC) function helps to lessen this problem.

Table 5-2. Typical C-V measurement conditions

Frequency	10 kHz to 1 MHz (10 kHz to 100 MHz for a thin gate oxide layer measurement)
Capacitance range	0.0001 to 1000 pF
Capacitance accuracy	±0.1%
Test signal level	20 or 30 mVrms typical
DC bias voltage	0 to ± 40 V
Bias voltage resolution	≤ 10 mV
Bias voltage accuracy	≤ 10 mV

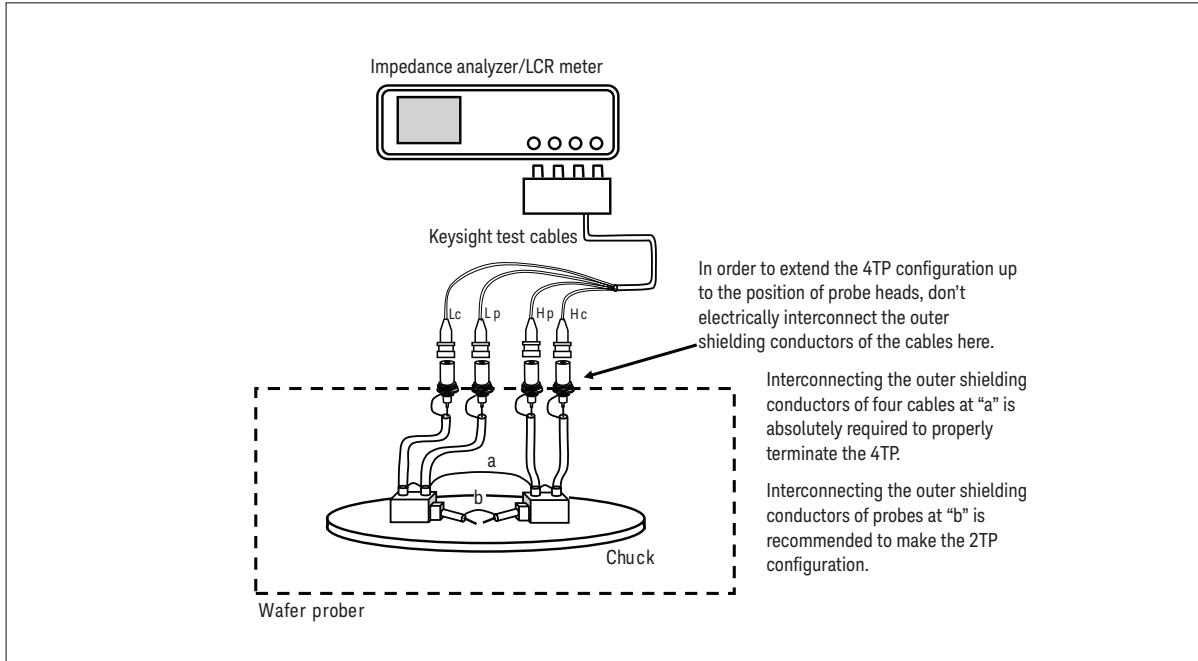


Figure 5-30. C-V measurement setup using 4TP cable extension

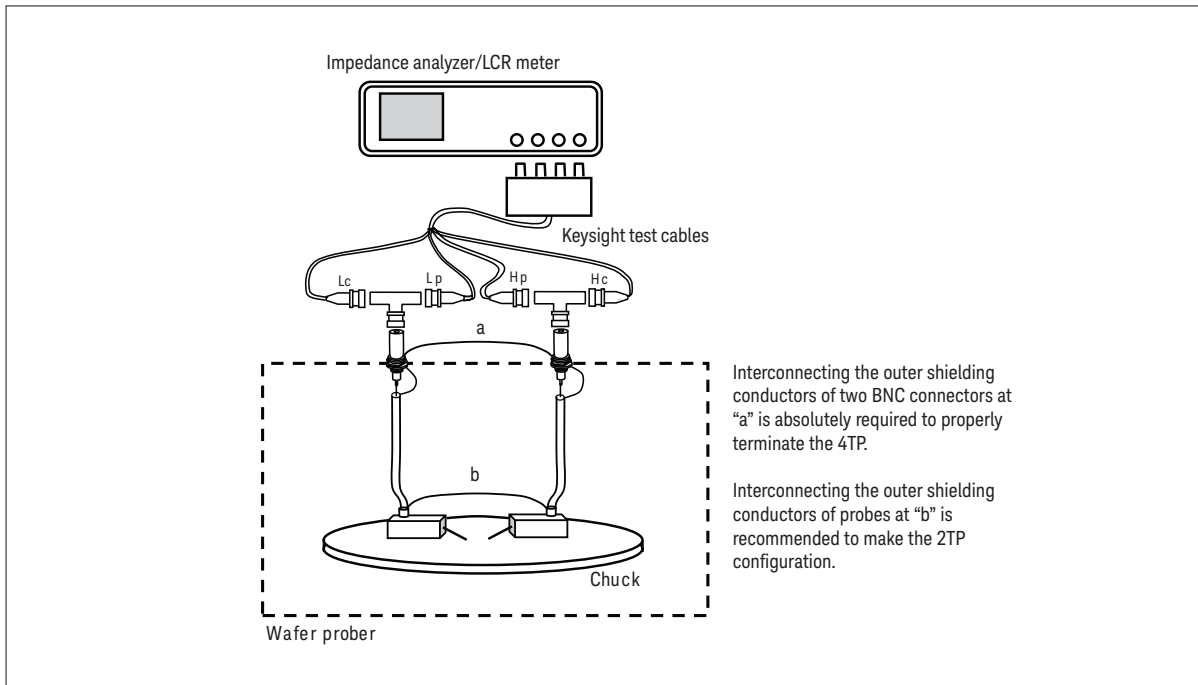


Figure 5-31. C-V measurement setup using 2TP cable extension

As a result of extremely high integration of logic LSIs using MOS FETs, the thickness of the MOS FETs' gate oxide layer is becoming thinner (less than 2.0 nm), and such MOS FETs have been produced recently. In evaluating these kinds of MOS FETs, leakage current becomes larger by the tunneling effect. Since the MOS gate capacitance has high impedance, most of the test signal's current flows as leakage current. Consequently, the C-V characteristic of MOS FET with a thin gate oxide layer cannot be measured accurately. To solve this problem, the test frequency should be set higher (1 MHz or more) than usual to reduce the capacitive impedance across the thin gate oxide layer to as low as possible. It is also important to simplify the measurement configuration to reduce residuals that exist in the measurement path. If you perform high-frequency C-V measurement using the 4TP configuration, the measurement error increases due to the residual inductance of the cable that is connected between the guard electrodes of probe heads. Also, the compensation does not work properly because the distance between probes easily varies. To solve this problem, a simplified 2T configuration with the 42941A impedance probe, as shown in Figure 5-32, is highly recommended for accurate high-frequency C-V measurement.

Note: Keysight offers an advanced C-V measurement solution for the ultra-thin gate oxide layer that uses the Keysight 4294A LF impedance analyzer. To eliminate the effects of tunneling leakage current, the MOS gate capacitance is calculated from the result of swept frequency impedance measurement ($|Z| - \theta$) at multiple DC bias points. (Refer to Application Note 4294-3, Evaluation of MOS Capacitor Oxide C-V Characteristics Using the Keysight 4294A, literature number 5988-5102EN.)

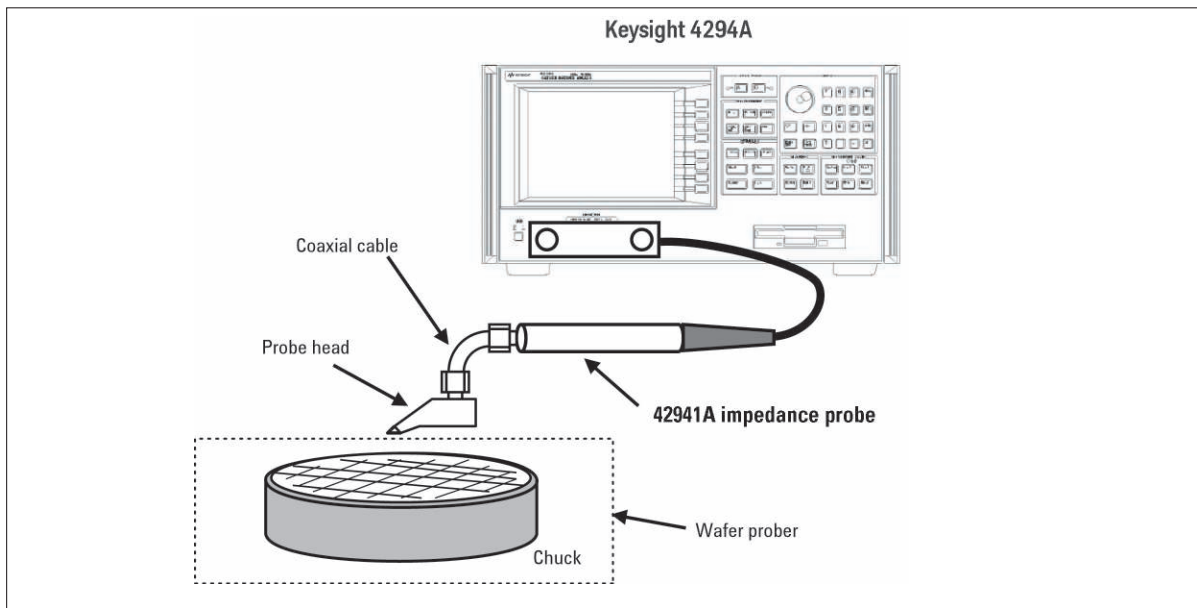


Figure 5-32. Example of high-frequency C-V measurement system configuration

5.7 High-frequency impedance measurement using the probe

As shown in Table 5-3, an RF I-V instrument can be used for a wafer's L, C, and R measurements, which are measurements in RF frequencies. Figure 5-33 shows an example of a measurement configuration when using the RF I-V instrument. This figure illustrates a measurement system configuration for using the E4991A RF impedance/material analyzer with a probe. Option E4991A-010, the probe station connection kit, makes it easier to establish a probing system that can perform on-wafer measurements from 1 MHz to 3 GHz. This kit contains a small test head and an extension cable.

The E4991A has calibration, compensation, and DC bias functions, and compared to a network analyzer, the E4991A provides a wider impedance measurement range and stable measurement performance (refer to Section 2.6.)

Table 5-3. Application examples of high-frequency impedance measurements using probe

Application	Parameters	DUT	Frequency	Measurement requirement
Spiral inductor	L, Q	RFIC for mobile phone	GHz	- Low inductance (nH range) - High Q
Transistor, Diode	C, D	CMOS FET, PIN diode for Transistor/diode optical use	MHz/GHz	- Low inductance (nH range) - Low capacitance (pF range)
Disk head	C, D	GMR head, magnetic head	MHz/GHz	- Low inductance
IC package	C, L	IC package	GHz	- Low inductance (nH range) - Low capacitance (pF range)
Memory	C, D	FRAM, DRAM, SRAM	MHz/GHz	- Low capacitance (pF range)
Dielectric material	C, D	Thin film layer, PC board	MHz/GHz	- Wide impedance range - Low-loss
Chip inductor/capacitor	L, Q C, D	Chip inductor Chip capacitor	MHz/GHz	- Stable contact to small electrodes - Wide impedance range - High Q/Low D

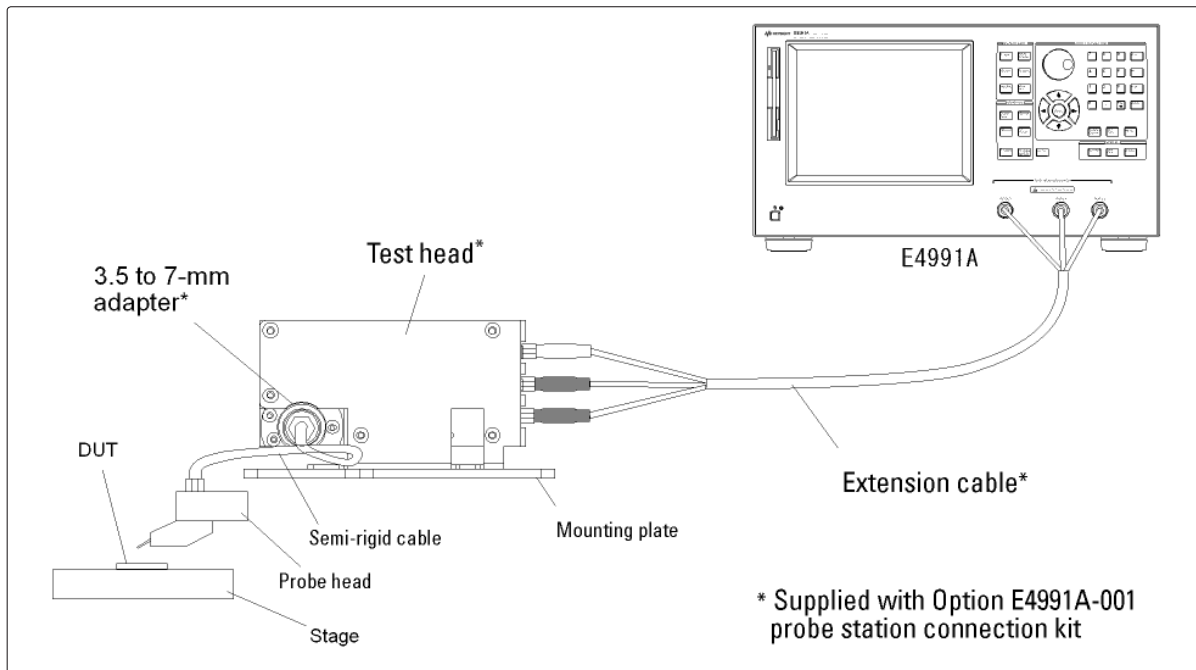


Figure 5-33. Impedance measurement configuration when using the RF I-V instrument

5.8 Resonator measurement

The resonator is the key component in an oscillator circuit. Crystal and ceramic resonators are commonly used in the kHz and MHz range. Figures 5-34 (a) and (b) show typical equivalent circuit and frequency response for a resonator. A resonator has four primary elements: C, L, R, and Co. C and L determine the series resonant frequency (f_r) and Co and L determine the parallel resonant frequency (f_a .) Qm (mechanical Q) is another measurement parameter used to describe the performance of resonators. An impedance analyzer or network analyzer is used to measure the resonator characteristics.

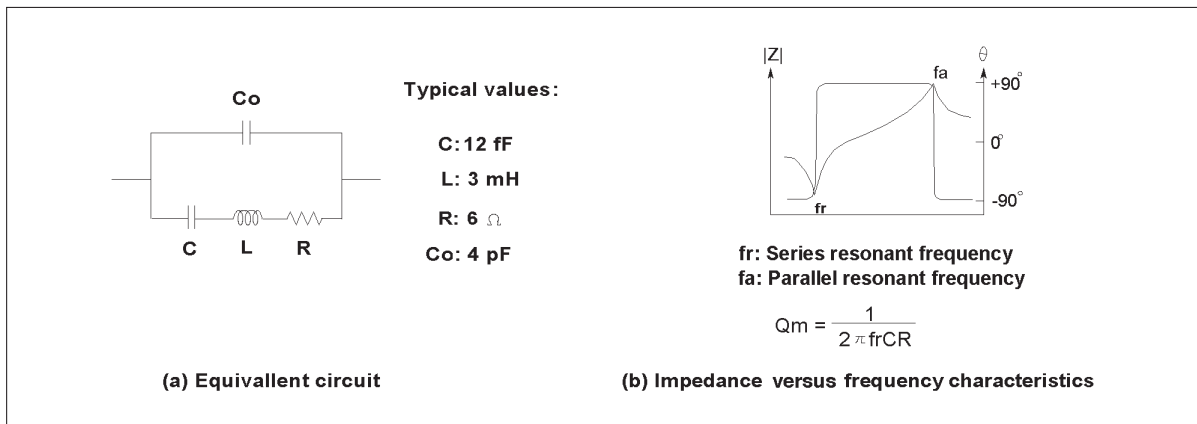


Figure 5-34. Typical resonator characteristics

In the following methods, note the impedance analyzer has an advantage in the accuracy of the measurement results.

Impedance analyzer advantages

- The impedance value at resonant frequency can be read directly. (Network analyzers generally read in units of dB.)
- Measurement accuracy for low impedance at series resonance and for high impedance at parallel resonance are better than in network analysis.
- Measurement is made by simply connecting the resonator to the test fixture, and residuals can be removed using the compensation function. (Network analyzers require a π network circuit to be connected and cannot compensate for all the residuals.)
- By using the equivalent circuit analysis function, all resonator parameters are easily known. (Network analyzers require complicated calculation or special analysis software to be used.)

Network analyzer advantages

- Faster measurement speed.
- Higher measurement frequency range.

Keysight's impedance analyzers are suitable for testing resonators. With their equivalent circuit analysis function, each resonator parameter can be determined individually. Also the I-BASIC programming function facilitates the calculation of Q_m and the extraction of other parameters. Figure 5-35 shows a resonator measurement setup using an auto-balancing bridge instrument for a frequency range up to approximately 100 MHz. For higher frequency measurement, the same setup can be used with RF I-V measurement instrument. Take the following precautions to ensure accurate measurements:

1. It is often assumed that the series resonant frequency, f_r , is coincident with the minimum impedance point. This is practical for an approximate measurement, but it is not the true value of f_r . The true value of f_r is given at $\theta = 0$ and is typically 1 to 2 Hz above the minimum impedance point. Search the 0° -phase angle point for f_r measurement.
2. It is important to properly set the oscillator output level; resonators are test-signal dependent. The minimum impedance value and the series resonant frequency may vary depending on the applied test signal level. Decrease the test signal level while monitoring the test current (I-monitor function) until the specified test level is obtained.
3. Perform an open/short compensation. Use All Point compensation mode instead of the interpolation mode because the resonator measurements are narrowband. Also, pay special attention to the short compensation procedure. Improper short compensation will result in measurement error for f_r and the minimum impedance value.
4. Keep the measurement temperature constant. Resonators are temperature sensitive. Place a resonator into the test fixture with your hand and wait until the series resonant frequency becomes constant.

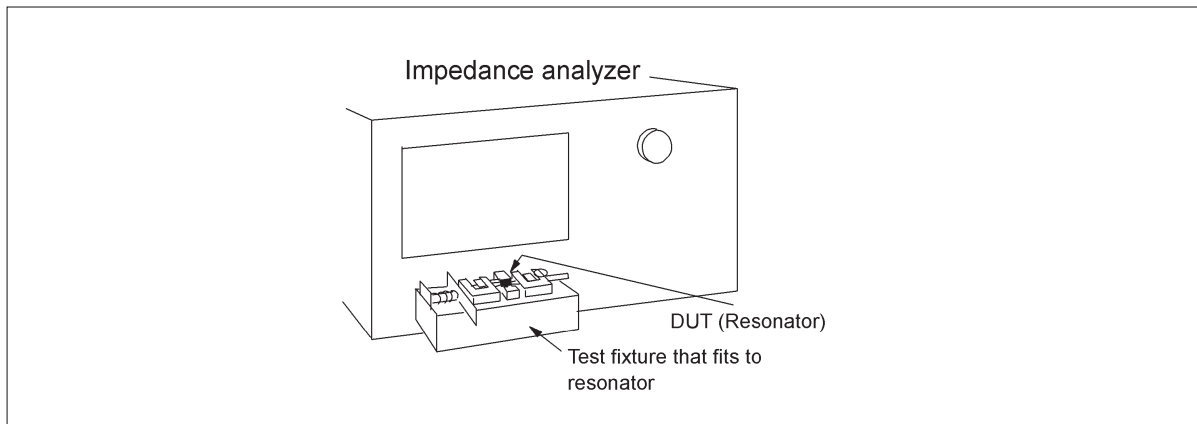


Figure 5-35. Resonator measurement setup

Figures 5-36 (a) and (b) show an example of an impedance-phase characteristic measurement and equivalent circuit analysis results for a crystal resonator. Equivalent circuit mode (E) serves to obtain the four-element equivalent circuit parameter values for a crystal resonator.

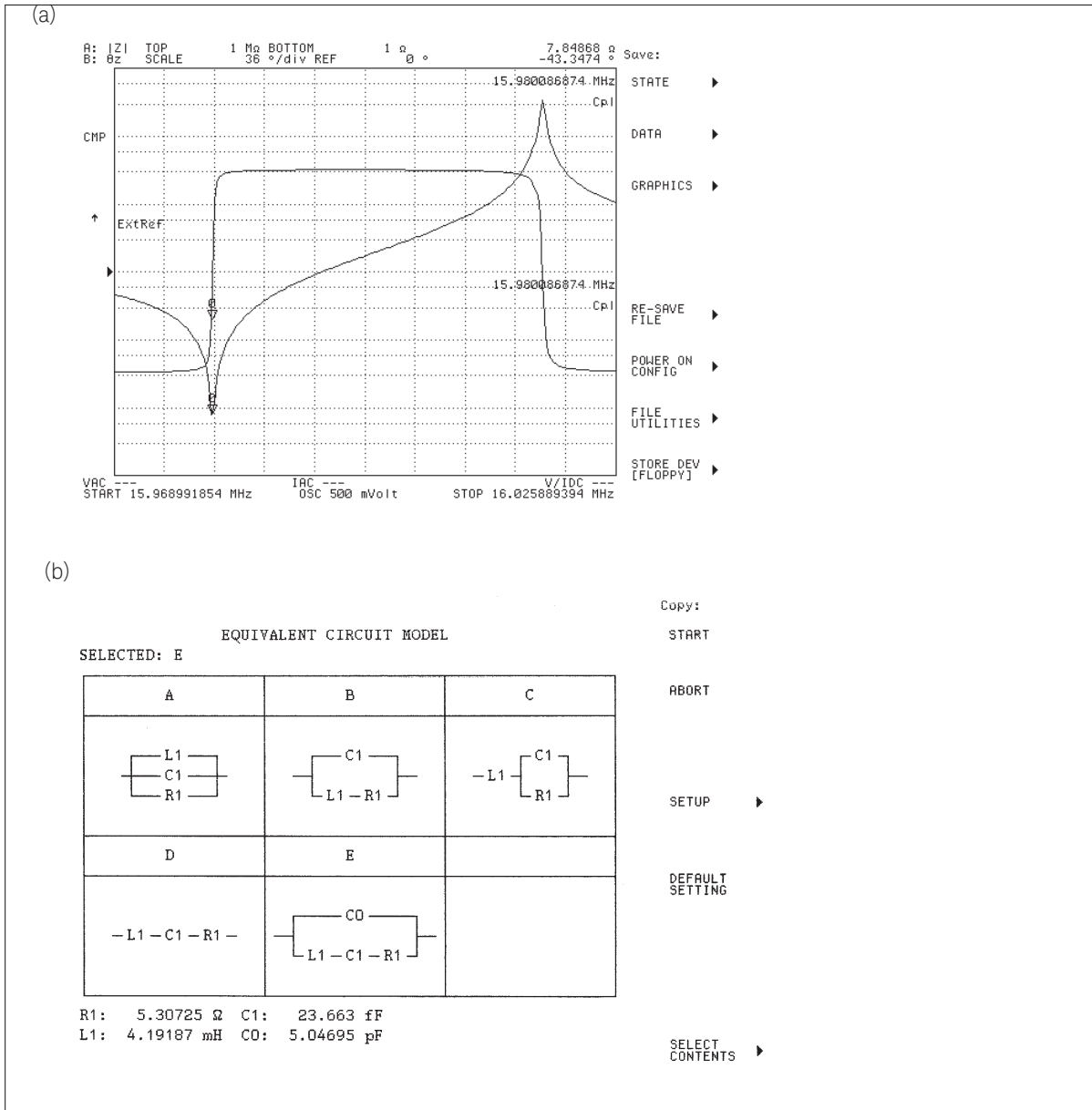


Figure 5-36. Resonator equivalent circuit mode

5.9 Cable measurements

The characteristic impedance ($Z(\Omega)$) capacitance per unit length (C (pF/m)), and the propagation constants α (dB/m) and β (rad/m) are parameters commonly measured when evaluating cables. Figure 5-37 shows a measurement setup for coaxial cable using an auto-balancing bridge type impedance analyzer and the 16047E test fixture. Note that the High terminal of the test fixture is connected to the outer conductor of the cable. This measurement setup avoids the effects of noise picked up by the outer conductor of the cable and is important to regard when the cable length is long. The characteristic impedance and propagation constants are determined by measuring the impedance of the cable with its other end opened and shorted (open-short method), and calculating using the equations shown in Figure 5-37. The I-BASIC programming function of the impedance analyzer facilitates the calculations required. Figure 5-38 demonstrates an example of measured characteristic impedance versus frequency.

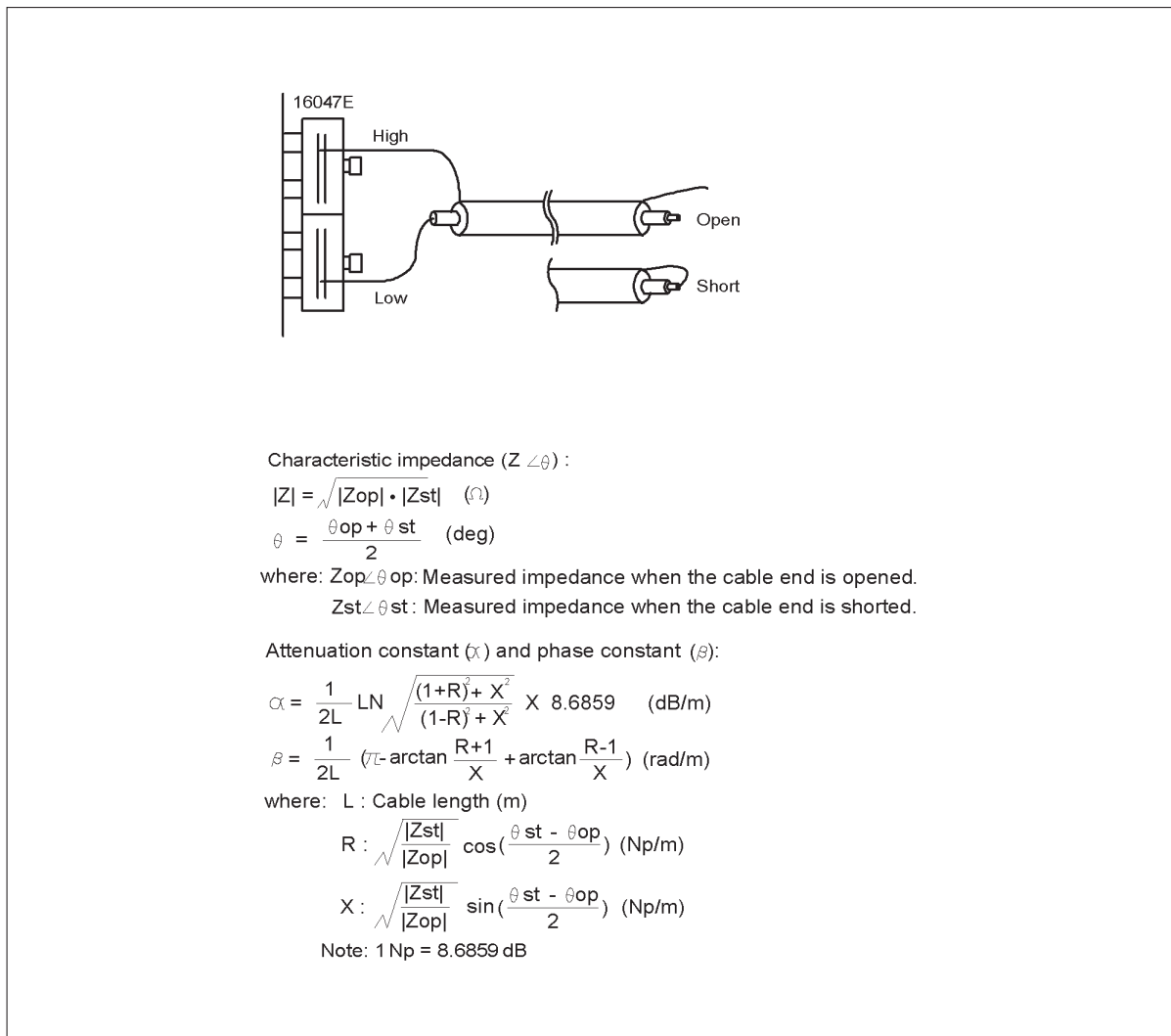


Figure 5-37. Coaxial cable measurement setup and parameter calculation

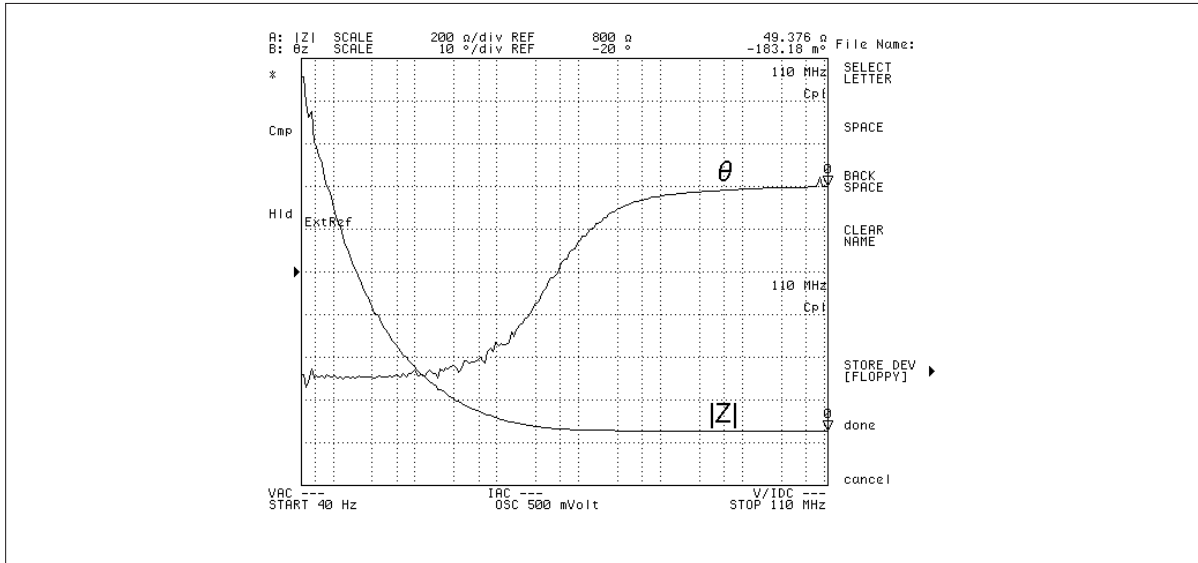


Figure 5-38. Measurement result

5.9.1 Balanced cable measurement

A balun transformer is required for measuring balanced cable because the instrument's UNKNOWN terminal is unbalanced (refer to Section 5.10.) Figure 5-39 shows the measurement setup for a balanced cable. A balanced/unbalanced 4T converter (Keysight part number 16314-60011) can be used to measure balanced cables from 100 Hz to 10 MHz using an auto-balancing bridge instrument. For measurement using a network analyzer, 16315-60011, 16316A, and 16317A are available. These converters have different characteristic impedance to allow impedance matching with DUT (cable) impedance of 50, 100 and 600 Ω , respectively, as shown in Table 5-4.

Table 5-4. 16314-60011, 16315-60011, 16316A, and 16317A

Converter	Characteristic impedance		Applicable instrument
	Unbalanced side	Balanced side	
16314-60011	50 Ω	50 Ω	Auto-balancing bridge instrument
16315-60011	50 Ω	50 Ω	Network analyzer
16316A	50 Ω	100 Ω	
16317A	50 Ω	600 Ω	

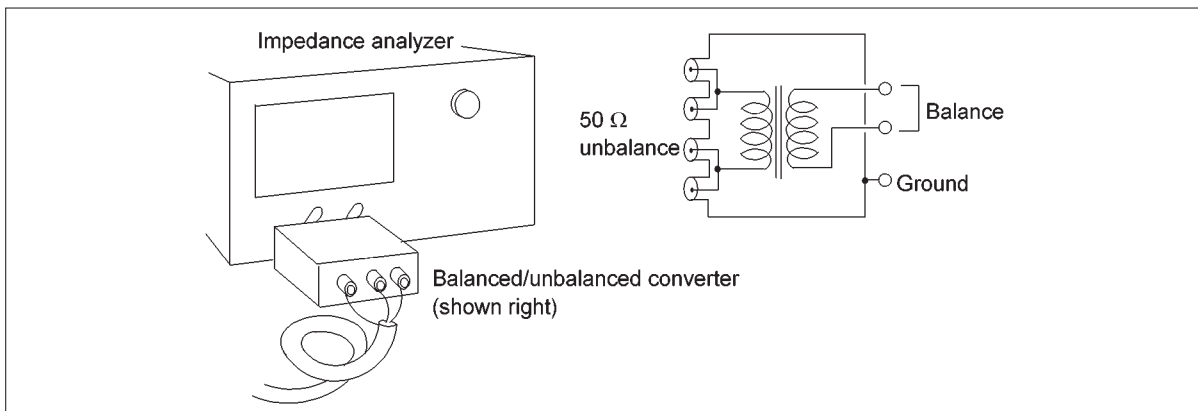


Figure 5-39. Balanced cable measurement setup

5.10 Balanced device measurement

When a balanced DUT (such as balanced cable or the balanced input impedance of a differential amplifier) is measured, it is necessary to connect a “balun” (balance-unbalance) transformer between the instrument and the DUT. Looking from the DUT side, the UNKNOWN terminals of the impedance measurement instrument are in an “unbalanced” configuration. Figure 5-40 (a) shows an example of an auto-balancing bridge instrument. Its Low terminal is considered a virtual ground because it is held at approximately a 0 V potential. When a 1:1 balun transformer is connected as shown in Figure 5-40 (b), the instrument can measure a balanced DUT directly.

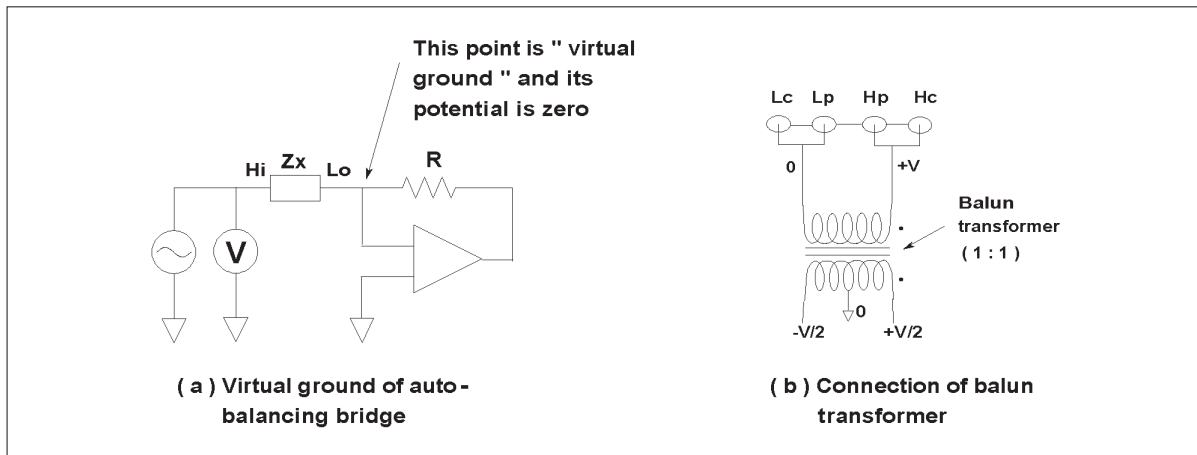


Figure 5-40. Balanced device measurement

An actual balun transformer has a limited frequency range. The measurement must be made within its frequency range. In addition to Keysight’s balanced/unbalanced converters, various types of commercial balun transformers are available for various frequency ranges. To select the appropriate balun transformer, check the frequency range and the impedance of the transformer’s balanced (DUT) side. Its impedance should be close to the characteristic impedance of the DUT. The impedance of the unbalanced side should be 50 or 75 Ω as appropriate for the measurement instrument. Open/short/load compensation for the balun transformer is required when the turns ratio of the balun transformer used is not 1:1, or when an accurate measurement is needed. Open/short compensation is not adequate because the balun transformer will produce both magnitude ($|Z|$) and phase errors due to its transfer function characteristic. The terminal connectors of the balanced side should be connectable for both the standard devices used for open/short/load compensation and the DUT. Figures 5-41 (a) through (d) show an example of an actual balun configuration and compensation.

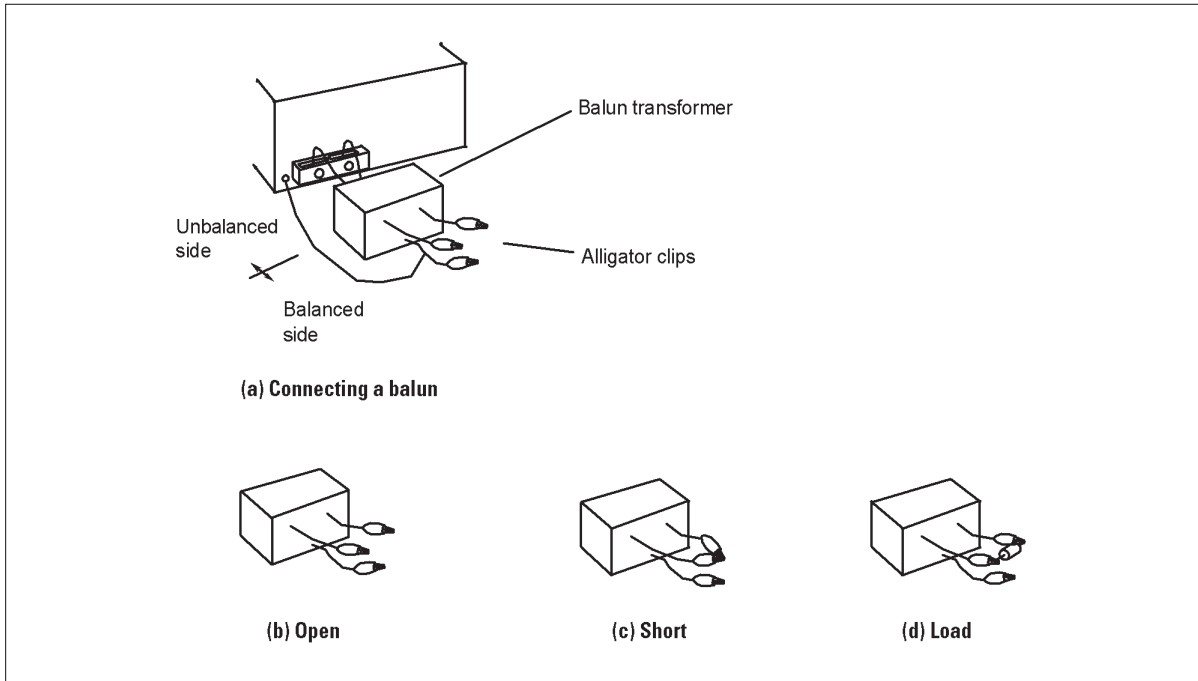


Figure 5-41. Measurement setup

5.11 Battery measurement

The internal resistance of a battery is generally measured using a 1 kHz AC signal. It is not allowed to directly connect a battery to the auto-balancing bridge type impedance measurement instrument. If a battery is connected directly, the instrument becomes the DC load, typically 100 Ω for the battery. The instrument may be damaged by a discharge current flow from the battery. Figure 5-42 shows the recommended setup for this measurement. C_1 and C_2 block DC current from flowing into the instrument. The value of C_1 should be calculated using the minimum measurement frequency. For example, when the measurement is made at 1 kHz and above, C_1 should be larger than 32 μF . The voltage rating of C_1 and C_2 must be higher than the output voltage of the battery.

Note: The Keysight 4338B milliohm meter can measure the internal resistance of a battery up to 40 V DC directly connected to the measurement terminals because the DC blocking capacitors have been installed in the 1 kHz bridge circuit.

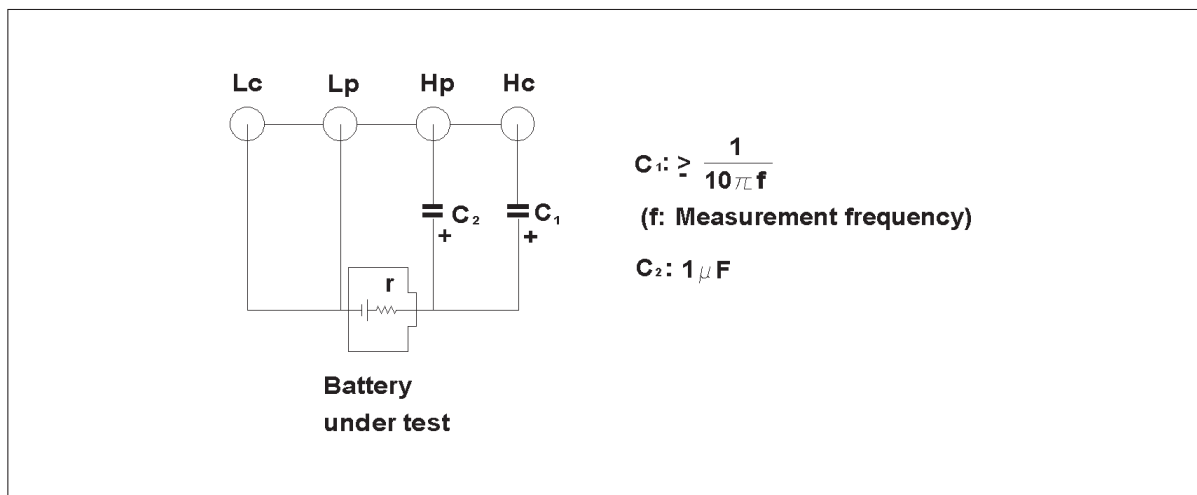


Figure 5-42. Battery measurement setup

5.12 Test signal voltage enhancement

When measuring the impedance of test signal level dependent devices, such as liquid crystals, inductors, and high value ceramic capacitors, it is necessary to vary the test signal voltage. Many of the auto-balancing bridge instruments employ a test signal source whose output is variable, typically from 5 mV to 1V rms. Particularly, the E4980A precision LCR meter with Option E4980A-001 can output a test signal voltage of up to 20 V rms and is the most suitable for this application.

In some cases, measurement needs exist for evaluating impedance characteristics at large test signal voltages beyond the maximum oscillator output level of the instrument. For auto-balancing bridge instruments, output voltage enhancement is possible if the test signal is amplified as shown in Figure 5-43. A voltage divider is also required so that the input voltage of the Hp terminal is the same as the output voltage of the Hc terminal. The DUT's impedance is a concern. Because the current flowing through the DUT is also amplified and flows directly into the Rr circuit, it should not exceed the maximum allowable input current of the Lc terminal. Typically, this is 10 mA. For example, when a 10 V rms signal is applied to the DUT, the minimum measurable impedance is $10 \text{ V}/10 \text{ mA} = 1 \text{ k}\Omega$. Also, it should be noted that measured impedance is $1/A$ (gain of amplifier) of an actual DUT's impedance. For example, when a 10 pF capacitor is measured using $\times 10$ amplifier, displayed value will be 100 pF.

Note: For RF I-V instrument, it is impossible to amplify the test signal because at the test port the signal source output is not separate from the voltmeter and current meter inputs.

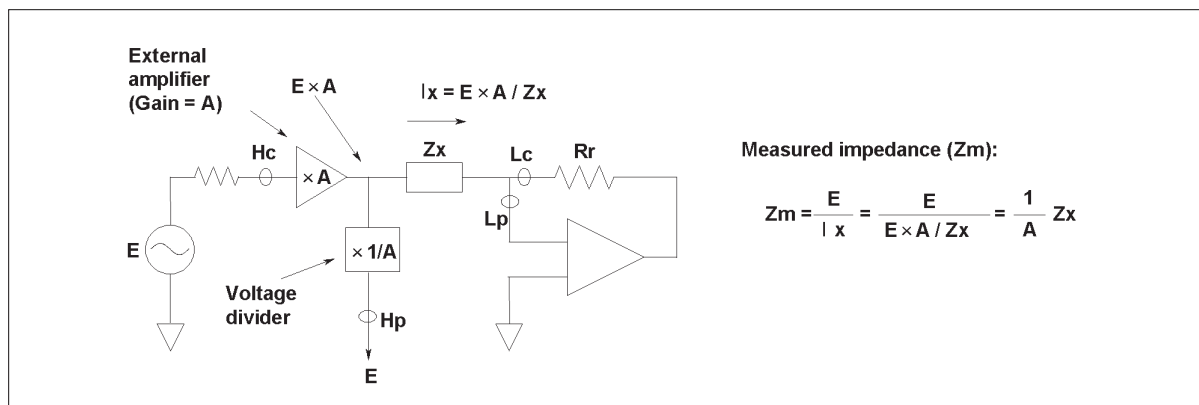


Figure 5-43. Schematic diagram of test signal voltage enhancement circuit

Figure 5-44 shows a measurement setup example to boost the test signal voltage by factor of 10 ($A = 10$). The amplifier used in this application should have constant gain in the measurement frequency range and output impedance less than 100Ω . R_3 in Figure 5-44 needs to be adjusted to compensate for the magnitude error in measured impedance and C_2 needs to be adjusted for flat frequency response. This can be accomplished by comparing the measured values with known values of a reference device. For better accuracy, perform the open/short/load compensation at a test signal level below 1 V rms (not to cause an excessive current to flow in short condition.) The required circuit constants of the divider are different depending on the input impedance of the H_p terminal of the instrument.

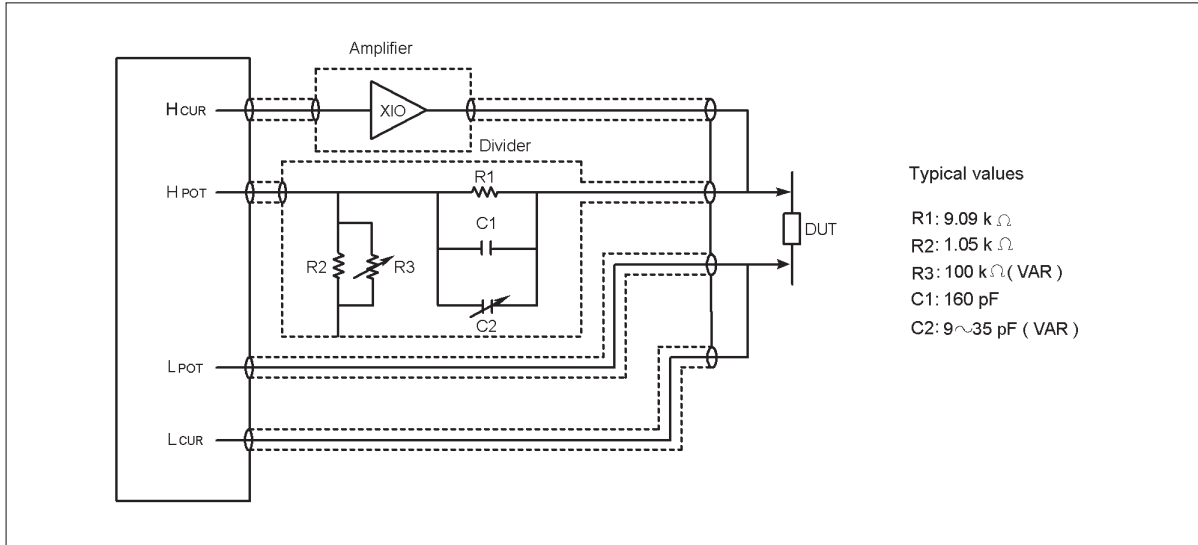


Figure 5-44. Connection diagram of test signal voltage enhancement circuit

5.13 DC bias voltage enhancement

DC biased impedance measurement is popularly used to evaluate the characteristics of the device under conditions where the device actually operates in circuits. The internal DC bias function of impedance measurement instruments is normally designed to apply a bias voltage to capacitor DUTs. It is suited to DC biased capacitor measurements.

Maximum applicable bias voltage is different for instruments. The internal bias source can typically output a variable bias voltage of up to ± 40 V through the Hc terminal. An external DC voltage source is required to apply a DC bias voltage that must exceed the limits of the internal DC bias function.

Some instruments have a DC bias input terminal for connecting an external DC voltage source. Use an external bias fixture or adapter for other instruments with no internal DC bias and for DC bias requirements that exceed the maximum voltage of the bias input terminal. Table 5-5 lists the available bias fixture and adapters.

Table 5-5. External bias fixture and adapters

Model number	Product type	Applicable instrument	Maximum bias voltage and current	Usable frequency range	Applicable DUT type*
16065A	Bias fixture	Auto-balancing bridge	± 200 V, 2 mA	50 Hz to 2 MHz	Leaded
16065C	Bias adapter	Auto-balancing bridge	± 40 V, 20 mA	50 Hz to 2 MHz	Leaded and SMD
16200B	Bias adapter	RF I-V 4294A+ 42942A	± 40 V, 5 A	1 MHz to 1 GHz	Leaded and SMD

Note: Applicable DUT types for the 16065C and 16200A depend on the test fixture connected.

Use the 16065A external voltage bias fixture, which has a built-in protection circuit, for leaded devices and high voltage DC bias of up to ± 200 V. Figure 5-45 shows the setup for a +200 V DC biased measurement. Since the 16065A is equipped with a bias monitor output, a digital voltmeter is used to monitor the DC bias voltage actually applied to the DUT. The 16065C external voltage bias adapter is designed to apply a bias voltage of up to ± 40 V from an external voltage source. This adapter can be connected between any 4TP test fixture and the instrument's UNKNOWN terminals, thus allowing the use of an appropriate test fixture that accommodates the DUT. The 16200B external DC bias adapter operates specifically with the RF I-V measurement instruments and the 4294A with the 42942A. This adapter resolves both voltage bias and current bias needs. When used for capacitor measurements, it allows a bias voltage of up to 40 V DC across the DUT by using an external DC voltage source.

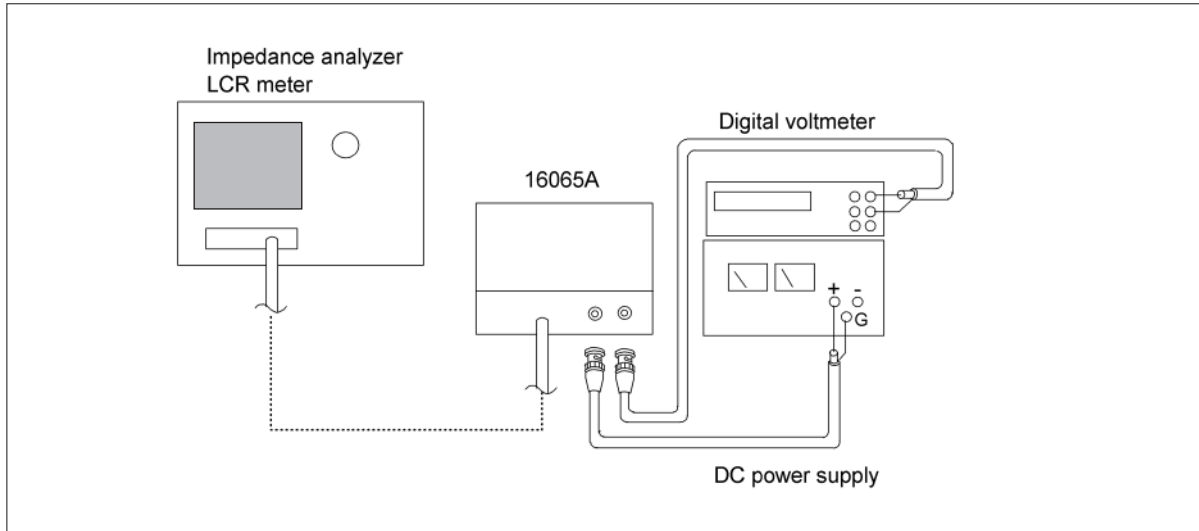


Figure 5-45. External DC bias measurement setup

5.13.1 External DC voltage bias protection in 4TP configuration

If the measurement frequency is above 2 MHz or the type of DUT is not suitable for these external bias fixtures, it is recommended that a protective circuit, shown in Figure 5-46, is used. This circuit is usable with bias voltage up to ± 200 V. To reduce the effects of this additional circuit, perform the open/short compensation with no bias voltage applied.

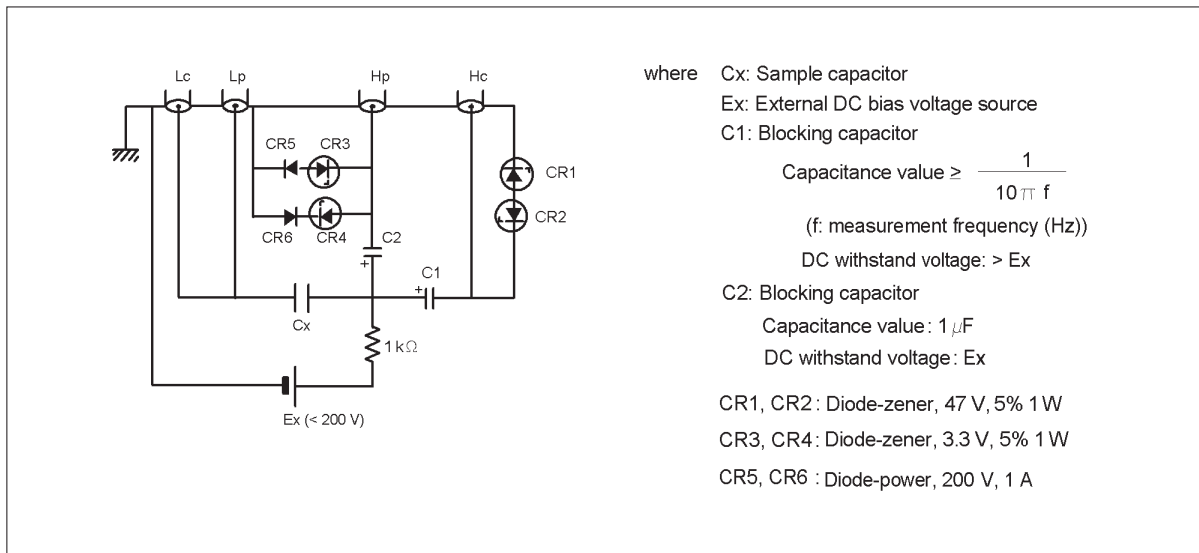


Figure 5-46. External DC voltage bias protection circuit

5.14 DC bias current enhancement

DC current biasing is used for inductor and transformer measurement. In the low frequency region, the E4980A or 4284A precision LCR meter with the 42841A bias current source are both suitable for this application because they can apply up to 20 A of bias current. (This can be extended up to 40 A if two 42841As are connected in parallel.)

To deliver a bias current in RF impedance measurement, the 16200B external DC bias adapter can be used with the RF I-V measurement instrument. The 16200B allows you to supply a bias current of up to 5 A across the DUT by using an external DC current source. The 16200B is directly attached to the 7-mm test port and the test fixture onto the 16200B as shown in Figure 5-47. To minimize the bias adapter-induced errors, perform open/short/load calibration at the test fixture terminals with no bias voltage/current applied.

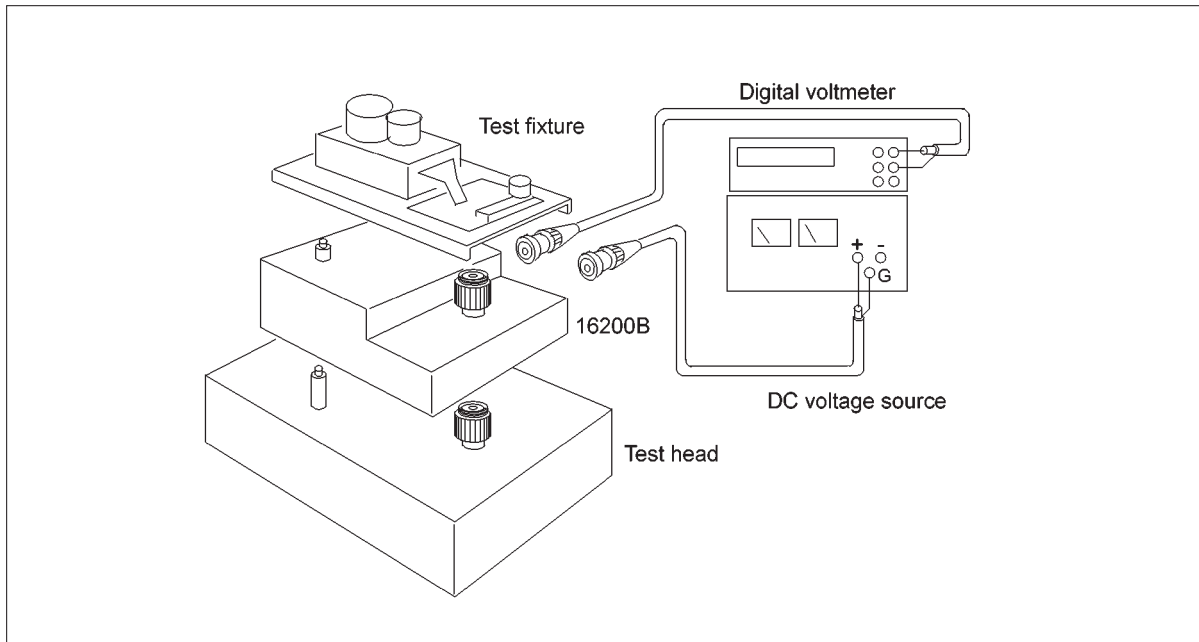


Figure 5-47. External DC bias measurement using the RF I-V measurement instrument

5.14.1 External current bias circuit in 4TP configuration

For external current bias measurement using other auto-balancing bridge instruments, an external DC current source and a protection circuit are required. The following describes a protection circuit that can be used for DC bias current measurements up to 10 A. Figure 5-48 shows the protection circuit schematic diagram.

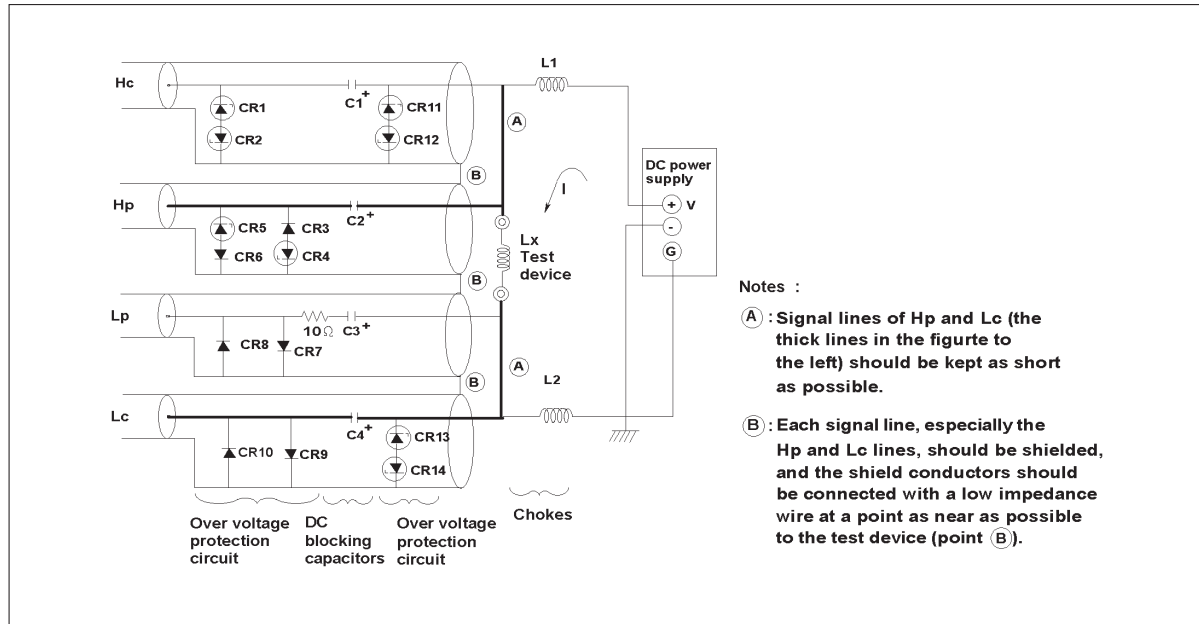


Figure 5-48. External current bias protection circuit

Take caution of electrical shock hazards when using the external DC bias circuit.

A large energy is charged in L_1 and L_2 , as well as the DUT (L_x), by a bias current delivered from an external power supply and when the DUT is disconnected from the measurement circuit, the DUT generates a very high spike voltage (kick-back voltage) to discharge the energy. To ensure operator safety, decrease the bias current to zero before disconnecting the DUT.

L_1 and L_2 discharge through the protection circuit the instant the DUT is disconnected from the measurement circuit or when the bias current is turned off. To prevent the instrument from being damaged by harmful discharge, the protection circuit must be designed carefully for the withstanding voltage/current rating of each circuit component. Refer to Application Note 346 A Guideline for Designing External DC Bias Circuit for more information.

5.15 Equivalent circuit analysis and its application

Keysight's impedance analyzers are equipped with an equivalent circuit analysis function. The purpose of this function is to model the various kinds of components as three- or four-element circuits. The values of the component's main elements and the dominant parasitics can be individually determined with this function.

Many impedance measurement instruments can measure the real (resistive) and the imaginary (inductive or capacitive reactance) components of impedance in both the series and parallel modes. This models the component as a two-element circuit. The equivalent circuit analysis function enhances this to apply to a three- or four-element circuit model using the component's frequency response characteristics. It can also simulate the frequency response curve when the values of the three- or four-element circuit are input.

Impedance measurement at only one frequency is enough to determine the values of each element in a two-element circuit. For three- or four-element circuits, however, impedance measurements at multiple frequencies are necessary. This is because three (four) equations must be set up to obtain three (four) unknown values. Since two equations are set up using one frequency (for the real and imaginary), one more frequency is necessary for one or two more unknowns. The equivalent circuit analysis function automatically selects two frequencies where the maximum measurement accuracy is obtained. (This is at the frequency where the $\sqrt{2} \times$ minimum value or $1/\sqrt{2} \times$ maximum value is obtained.) If the equivalent circuit model (described later) is properly selected, accuracy for obtained values of a three- or four-element circuit is comparable to the measurement accuracy of the instrument.

The equivalent circuit analysis function has five circuit modes as shown in Figure 5-49, which also lists their applications. The following procedure describes how to use the equivalent circuit analysis function.

1. Perform a swept frequency measurement for the unknown DUT using the $|Z| - \theta$ or $|Y| - \theta$ function. The sweep mode can be either linear or logarithmic.
2. Observe the frequency response curve. See the typical frequency response curve given in Figure 5-49. Choose the circuit mode that is most similar to the measured curve.
3. Calculate the equivalent parameters by pressing the "Calculate Parameter" key (or the key with the same function.) Three or four values for selected circuit mode are calculated and displayed.
4. Check the simulated frequency response curve. The simulated curve is calculated from the obtained equivalent parameters. If the fitting quality between the simulated curve and the actual measurement results is high, the proper circuit mode was selected. If not, try one of other circuit modes.

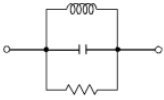
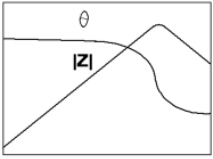
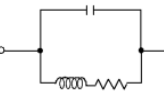
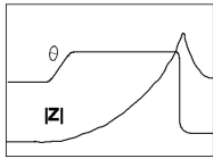
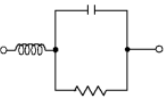
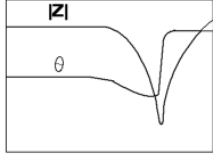
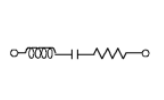
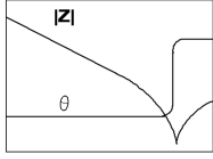
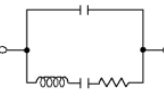
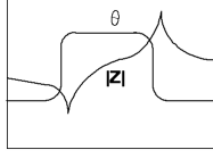
Equivalent circuit	Type of DUTs	$ Z - \theta$ f-characteristics
A 	<ul style="list-style-type: none"> Coils with high core loss 	
B 	<ul style="list-style-type: none"> Coils in general Resistors 	
C 	<ul style="list-style-type: none"> High-value resistors 	
D 	<ul style="list-style-type: none"> Capacitors 	
E 	<ul style="list-style-type: none"> Resonators (crystal, ceramic) 	

Figure 5-49. Equivalent circuit models

If the simulated frequency response curve partially fits the measurement results, it can be said that the selected circuit mode is proper only for that part of the frequency range that it fits. Figure 5-50 (a) shows an example measurement for a low value inductor. As shown in Figures 5-50 (b) and (c), the measurement result does not agree with the simulated curves over the full frequency range. The higher frequency region is well simulated by circuit mode A and the lower frequency region by circuit mode B. In other words, the circuit mode for the inductor is like the circuit mode A at the higher frequencies and like circuit mode B at lower frequencies. At the higher frequencies C and R in parallel with L are the dominant elements and circuit mode A describes the response curve best. At the lower frequencies L and series R are the dominant circuit elements and circuit B describes the response curve best. From these facts, we can determine that the real circuit mode should be the combination of circuit modes A and B, and is like Figure 5-51 (a). Figure 5-51 (b) lists an I-BASIC program to simulate the frequency response for the circuit given in Figure 5-51 (a). The value of R_s should be keyed in from the front panel and entered into the internal register, so that the calculation can be executed and the simulated curve obtained. In this example, the simulated curve agreed with the actual result as shown in Figure 5-51 (c) when the value of R_s is 1Ω .

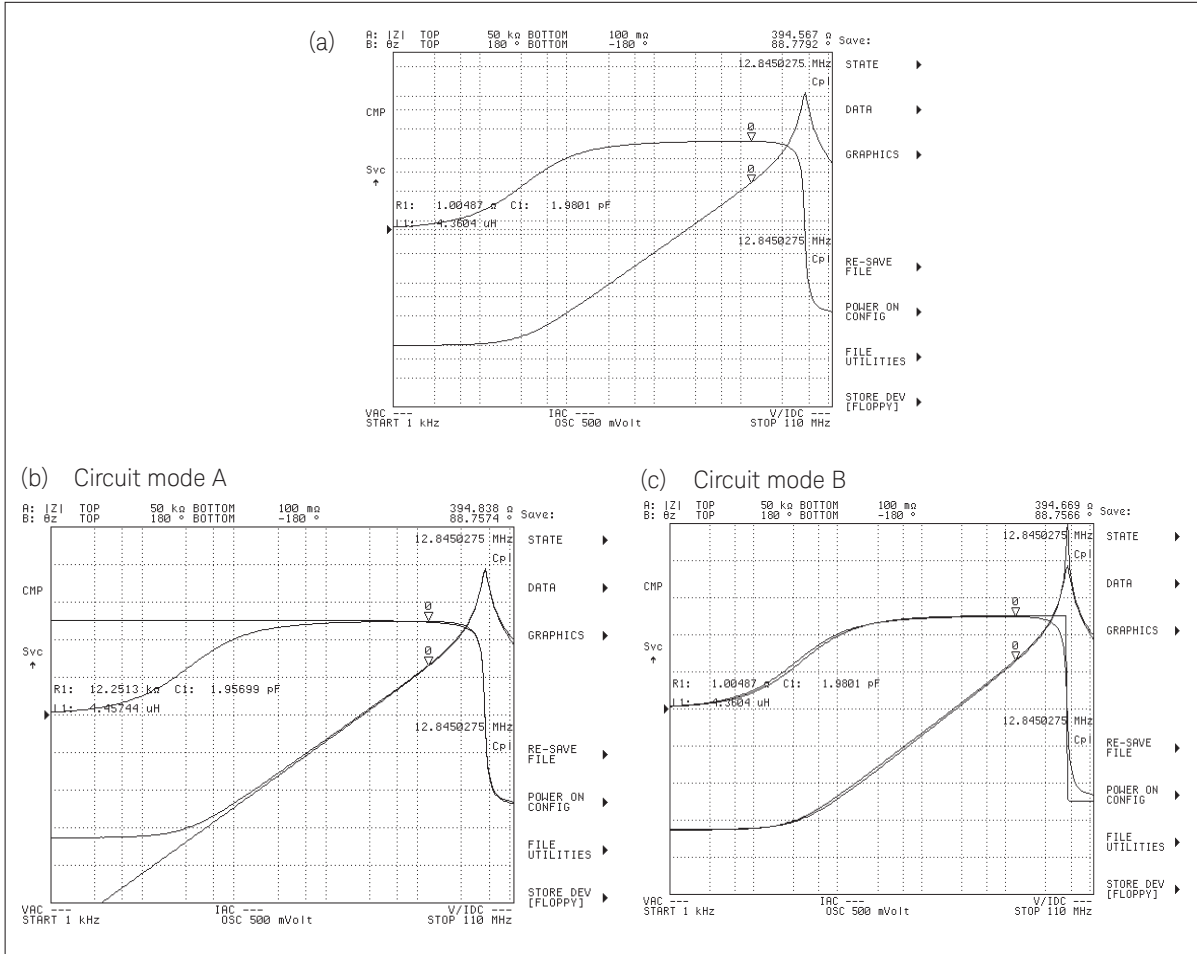


Figure 5-50. Frequency response simulation for a low-value inductor

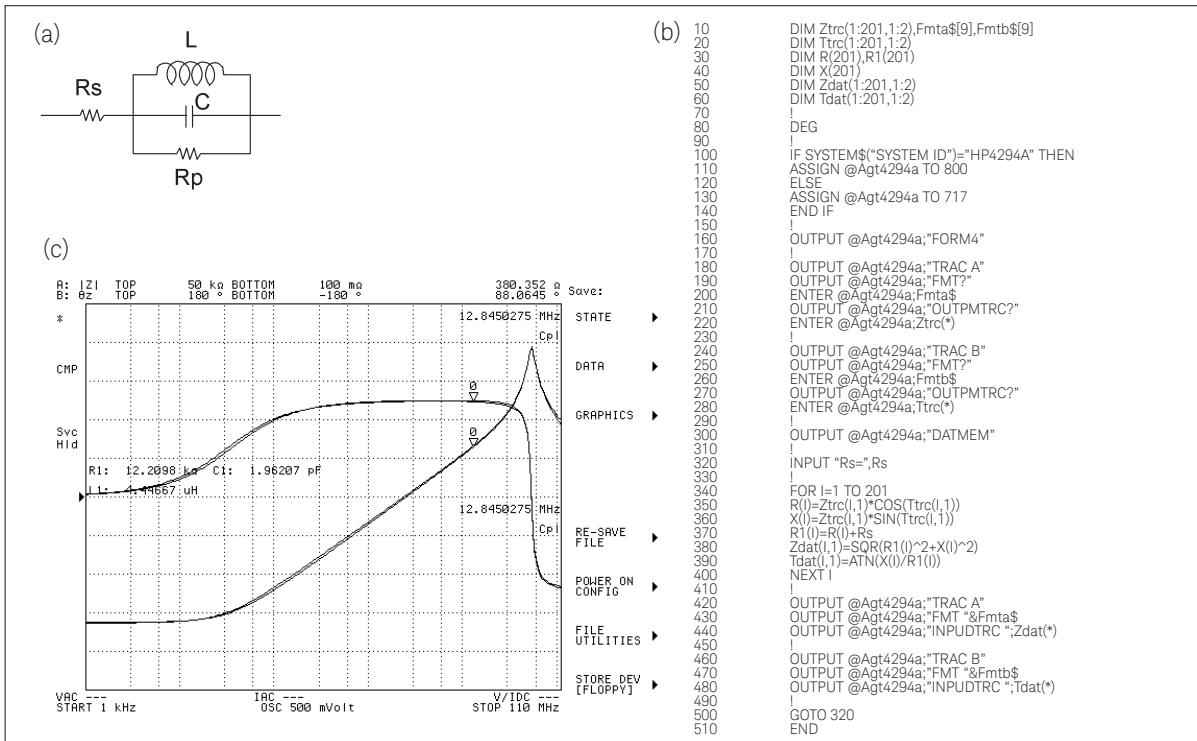


Figure 5-51. Equivalent circuit enhancement

Measurement accuracy can be improved by taking advantage of the equivalent circuit analysis. Figure 5-52 (a) shows an Ls-Q measurement example for an inductor. In this example, an impedance analyzer measures the Q value at 10 MHz. Measured data read by MARKER is Ls = 4.78 μH and Q = 49.6. The Q measurement accuracy for this impedance at 10 MHz is calculated from the instrument's specified D measurement accuracy of ±0.011, and the true Q value will be between 32 and 109. The reason that the uncertainty of the Q value is so high is that the small resistive component relative to reactance cannot be measured accurately. It is possible to measure the resistive component accurately if the inductive component is canceled by the capacitance connected in series with the inductor. When a loss-less capacitor of $1/(\omega^2L) = 53$ pF is connected, the inductor will resonate at 10 MHz. (In this example, a 46 pF capacitor is used for resonance.) Figure 5-52 (b) shows the |Z| - θ measurement results when a 46 pF capacitor is connected. This result can be modeled using circuit mode D, and the value of R is calculated to be 8.51 Ω. The value of L is obtained as 4.93 μH. Since the equivalent circuit analysis function uses approximately $8.51 \times \sqrt{2}$ Ω data to calculate the R value, the specified measurement accuracy for a 12 Ω resistance measurement can be used and is ±1.3 percent. Therefore, the Q value can be calculated from $Q = \omega L_s/R = 36.4$ with an accuracy of ±2.4% (sum of the L accuracy and R accuracy.) In this measurement, the capacitance value does not have to be exactly the calculated value but the loss of the capacitor should be very small because it will affect the calculated Q value.

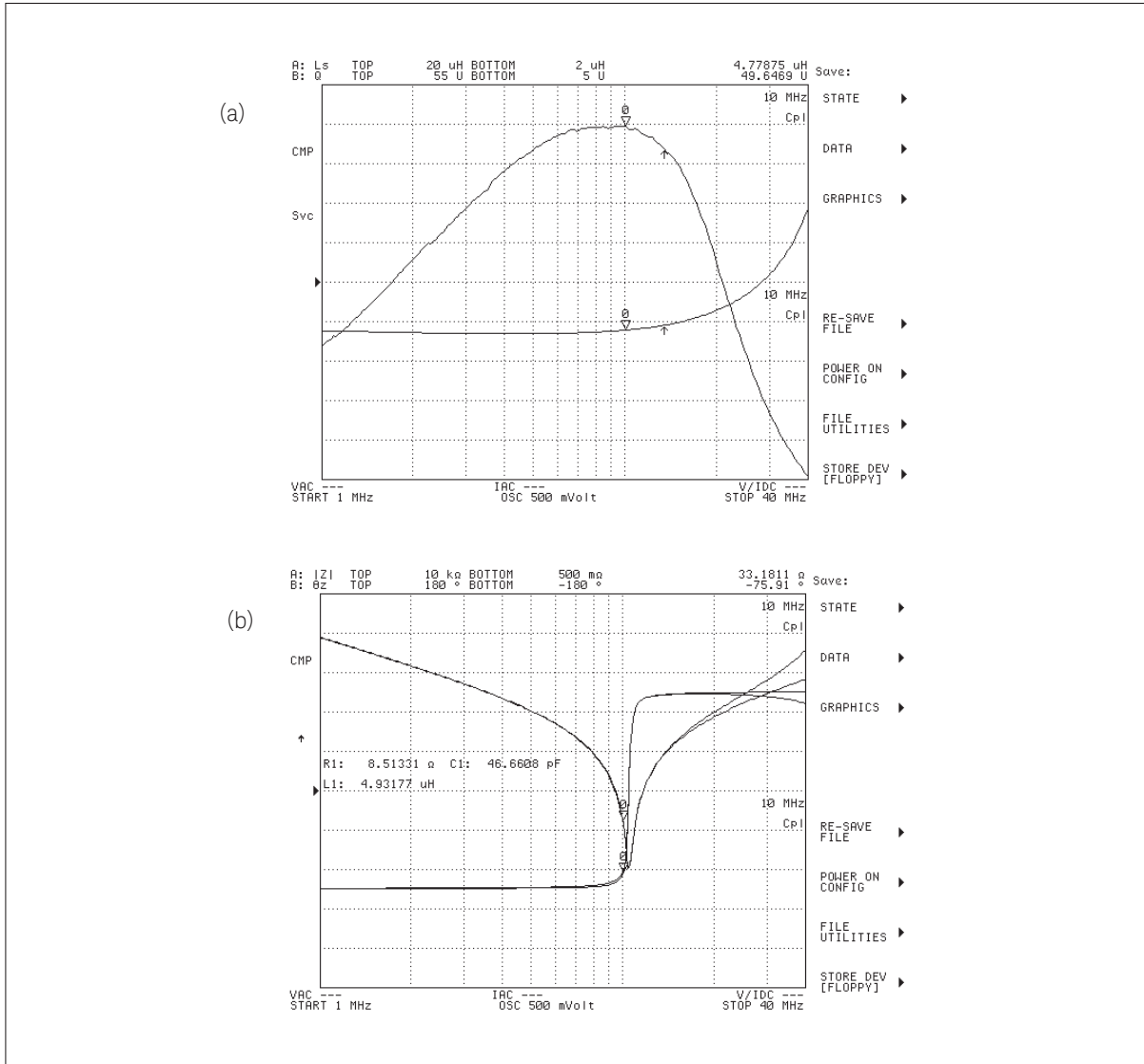


Figure 5-52. Q measurement accuracy improvement

Appendix A. The Concept of a Test Fixture's Additional Error

A.1 System configuration for impedance measurement

Frequently the system configured for impedance measurements uses the following components (see Figure A-1.)

1. Impedance measurement instrument
2. Cables and adapter interfaces
3. Test fixture

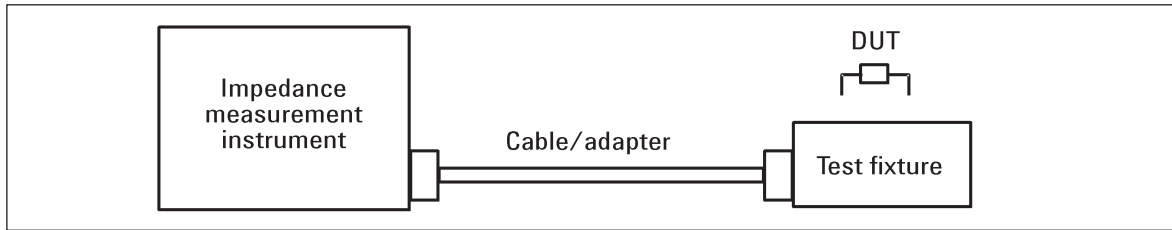


Figure A-1. System configuration for impedance measurement

The impedance measurement instrument's accuracy is defined at the measurement port of the instrument. This means that the accuracy of the measurement values at the measurement port is guaranteed and has calibration traceability.

In an actual measurement, there can be an extension of the measurement port with a cable or an adapter conversion to match the test fixture's terminal configuration. For this reason, cables and conversion adapters are provided for connectivity with the measurement port. These cables (and adapters) are designed to maintain high accuracy of the measurement instrument while extending the measurement port. Most of the time, the measurement accuracy of the instrument and the cable (or adapter) are specified together as a whole.

A test fixture is an accessory used to connect the DUT to the measurement instrument. Many test fixtures are provided to adapt to various shapes and sizes of DUTs. A test fixture is either connected directly to the measurement port of the instrument, or to the port of the extension cable or conversion adapter, as described earlier. The test fixture's structure determines the applicable frequency and impedance ranges. Hence, it is necessary to use the appropriate test fixture for the desired measurement conditions. In addition, each test fixture has its own inherent characteristic error, which is detailed in its operation manual.

A.2 Measurement system accuracy

The equation for the accuracy of a measurement system is:

$$(\text{Measurement accuracy}) = (\text{Instrument's accuracy}) + (\text{Test fixture's error})$$

The measurement instrument's accuracy is determined by an equation with terms that are dependent on frequency, measured impedance, signal level, and measurement time mode. By substituting the respective measurement conditions into the equation, the measurement accuracy is calculated. If a cable or a conversion adapter is used, then the specified measurement accuracy is the accuracy of the measurement instrument with the cable or adapter. This combined measurement accuracy is shown in the instrument's operation manual.

Typical equations for determining the test fixture's error are:

$$Z_e = \pm \{ A + (Z_s/Z_x + Y_o \times Z_x) \times 100 \} (\%)$$

$$D_e = Z_e/100 \quad (D \leq 0.1)$$

Z_e :	Additional error for impedance (%)
D_e :	Additional error for dissipation factor
A :	Test fixture's proportional error (%)
$Z_s/Z_x \times 100$:	Short offset error (%)
$Y_o \times Z_x \times 100$:	Open offset error (%)
Z_s :	Test fixture's short repeatability (Ω)
Y_o :	Test fixture's open repeatability (S)
Z_x :	Measured impedance value of DUT (Ω)

Proportional error, open repeatability, and short repeatability are mentioned in the test fixture's operation manual and in the accessory guide. By inputting the measurement impedance and frequency (proportional error, open repeatability, and short repeatability are usually a function of frequency) into the above equation, the fixture's additional error can be calculated.

A.2.1 Proportional error

The term, proportional error, A , is derived from the error factor, which causes the absolute impedance error to be proportional to the impedance being measured. If only the first term is taken out of the above equation and multiplied by Z_x , then $\Delta Z = A \times Z_x$ (Ω). This means that the absolute value of the impedance error will always be A times the measured impedance. The magnitude of proportional error is dependent upon how precisely the test fixture is constructed to obtain electrically and mechanically optimum matching with both the DUT and instrument. Conceptually, it is dependent upon the simplicity of the fixture's equivalent circuit model and the stability of residuals. Empirically, proportional error is proportional to the frequency squared.

A.2.2 Short offset error

The term, $Z_s/Z_x \times 100$, is called short offset error. If Z_x is multiplied to this term, then $\Delta Z = Z_s$ (Ω). Therefore, this term affects the absolute impedance error, by adding an offset. Short repeatability, Z_s , is determined from the variations in multiple impedance measurements of the test fixture in short condition. After performing short compensation, the measured values of the short condition will distribute around 0Ω in the complex impedance plane. The maximum value of the impedance vector is defined as short repeatability. This is shown in Figure A-2. The larger short repeatability is, the more difficult it is to measure small impedance values. For example, if the test fixture's short repeatability is $\pm 100 \text{ m}\Omega$, then the additional error of an impedance measurement under $100 \text{ m}\Omega$ will be more than 100 percent. In essence, short repeatability is made up of a residual resistance and a residual inductance part, which become larger as the frequency becomes higher.

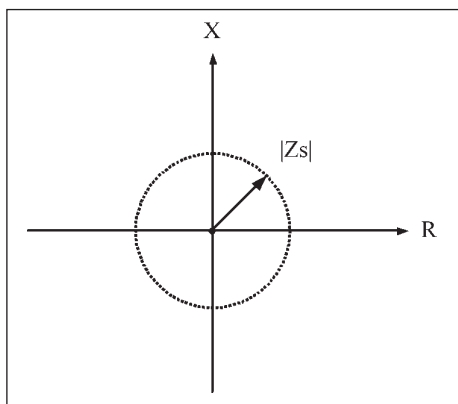


Figure A-2. Definition of short repeatability

A.2.3 Open offset error

The term, $Y_o \times Z_x \times 100$ is called open offset error. If Z_x is multiplied to this term, then $\Delta Y = Y_o$. This term affects the absolute admittance error, by adding an offset. Open repeatability, Y_o , is determined from the variations in multiple admittance measurements of the test fixture in the open condition. After performing open compensation, the measured values of the open condition will distribute around 0 S in the complex admittance plane. As shown in Figure A-3, the maximum value of the admittance vector in the complex admittance plane is defined as open repeatability. The larger open repeatability is, the more difficult it is to measure large impedance values. Open repeatability is made up of a stray conductance and a stray capacitance part, which become larger as the frequency becomes higher.

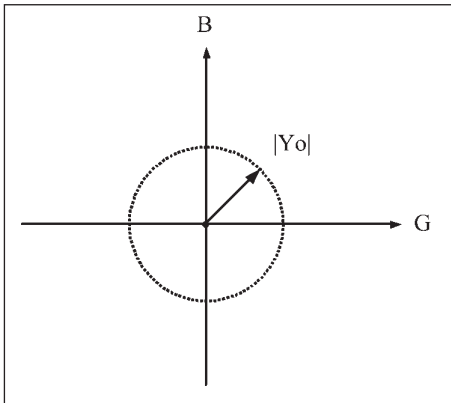


Figure A-3. Definition of open repeatability

A.3 New market trends and the additional error for test fixtures

A.3.1 New devices

Recently, the debut of extremely low ESR capacitors, and the trend to use capacitors at much higher frequencies, have increased demand for low impedance measurements. As a result, the test fixture's short repeatability has become increasingly important. In Figure A-4, the relationship between proportional error, short offset error, and frequency are shown when measuring low impedance of 100 mΩ and 10 Ω. Notice that when the measured impedance is less than 100 mΩ, short offset error influences the entirety of the test fixture's inherent error. As shown in the Figure A-4, when the DUT's impedance is 100 mΩ and the test fixture's short repeatability is 10 mΩ, the short offset error will be 10 percent. Since the proportional error is minimal in low frequencies, the additional error will also be 10 percent.

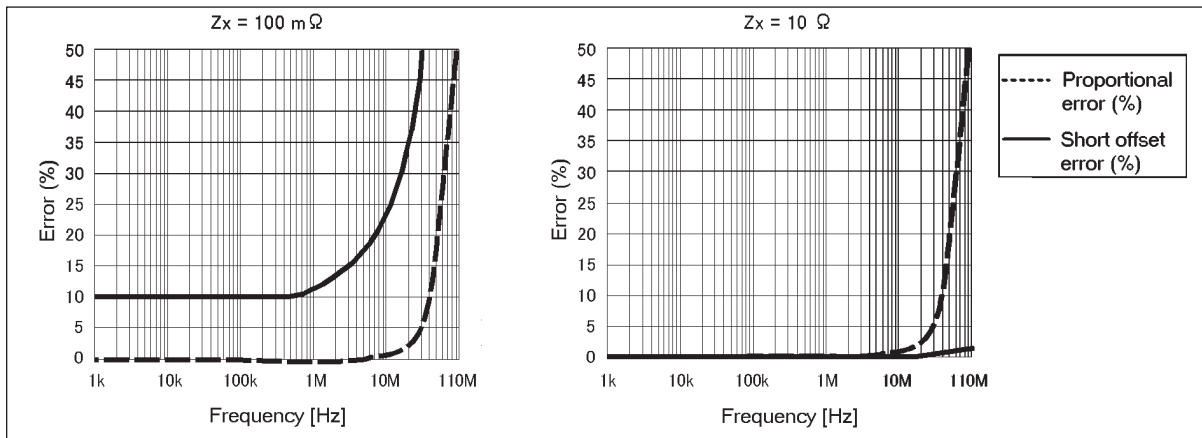


Figure A-4. Relationship between proportional error, short offset error, and frequency when measuring low impedance

Until recently, to allow for additional error in test fixtures it was common to just specify the proportional error (A.) As shown in the $10\ \Omega$ measurement case, if the measured impedance is large in comparison to the test fixture's short repeatability, then the short offset error can be ignored completely. This is the reason why open and short offset error was not previously specified. This is the reason for test fixtures that are only specified with proportional error. On the contrary, for measured impedance from $1\ \Omega$ to $10\ \text{k}\Omega$, proportional error (A) alone is sufficient to express the test fixture's additional error.

A.3.2 DUT connection configuration

In order to make short repeatability small, there are test fixtures that use the 4T connection configuration (for example, Keysight 16044A). By employing this technique, the effect of contact resistance is reduced and short repeatability is significantly improved. As a result, the range of accurate low impedance measurements is expanded down to a low milliohm region.

Figure A-5 shows the difference between the 2T connection and the 4T connection. In a 2T connection, the contact resistance that exists between the fixture's contact electrodes and the DUT, is measured together with the DUT's impedance. Contact resistance cannot be eliminated by compensation because the contact resistance value changes each time the DUT is contacted.

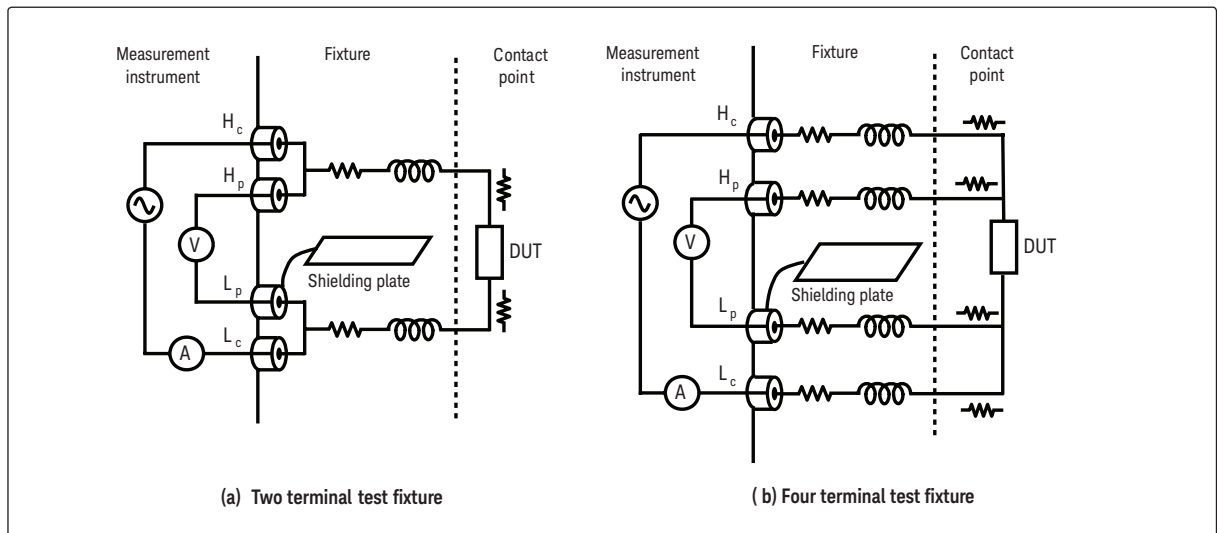


Figure A-5. Two-terminal and four-terminal connection techniques

In a 4T connection, the voltage and current terminals are separate. Since the voltmeter has high input impedance, no current flows into the voltage terminals. Hence, the voltage that is applied across the DUT can be accurately detected without being affected by the contact resistance. Also, the current that flows through the DUT flows directly into the current terminal and is accurately detected without being affected by the contact resistance. As a result, the 4T connection method can eliminate the effect of contact resistance and realize a small short repeatability. By using a 4T test fixture, it is possible to measure low impedance with better accuracy than that which can be measured with a 2T test fixture.

The 2T test fixture can be used up to a higher frequency than the 4T test fixture. Since the 2T test fixture has a simple DUT connection configuration, the effects of residuals and mutual coupling ($j\omega M$), which cause measurement error to increase with frequency, are smaller than those of the 4T test fixture and can be effectively reduced by compensation. Thus, the 2T connection is incorporated in test fixtures designed for use in the higher frequency region (typically up to 40 or 110 MHz.)

A.3.3 Test fixture’s adaptability for a particular measurement

In order to make use of what has been discussed previously, the test fixture’s adaptability for a particular measurement will be discussed. To see whether a test fixture is adaptable, it is important to think about the test fixture’s additional error (proportional error, short repeatability, and open repeatability), measurement impedance, and the test frequency range.

If the measurement impedance is in the 1 Ω to 10 kΩ range, use only proportional error to calculate the additional error of the test fixture. It is fine to assume that this is a close approximation to the fixture’s additional error.

If the measurement impedance is not in this range, use proportional error, short repeatability, and open repeatability to calculate the test fixture’s additional error. Recent test fixtures have all three terms specified in their operation manual, so use these values for the calculation.

Some of the recent test fixtures (16044A), due to their structure, have different performance characteristics with different measurement instruments. For these test fixtures, refer to their operation manual for more details about the specifications.

If the test fixture is not specified with short and open repeatability, how can the fixture’s adaptability be determined? To measure a test fixture’s short repeatability, measure the impedance of the short condition after performing short compensation. Take the shorting plate out of the fixture and then replace it. Measure the short condition again. By repeating this process at least 50 times, it will show the variations in the measured impedance of short condition (see Figure A-6.) The final step to determine an approximation of short repeatability is to add a margin to the values obtained. For open repeatability, measure the admittance of the test fixture’s open condition. In the same way, determine open repeatability by measuring at least 50 times.

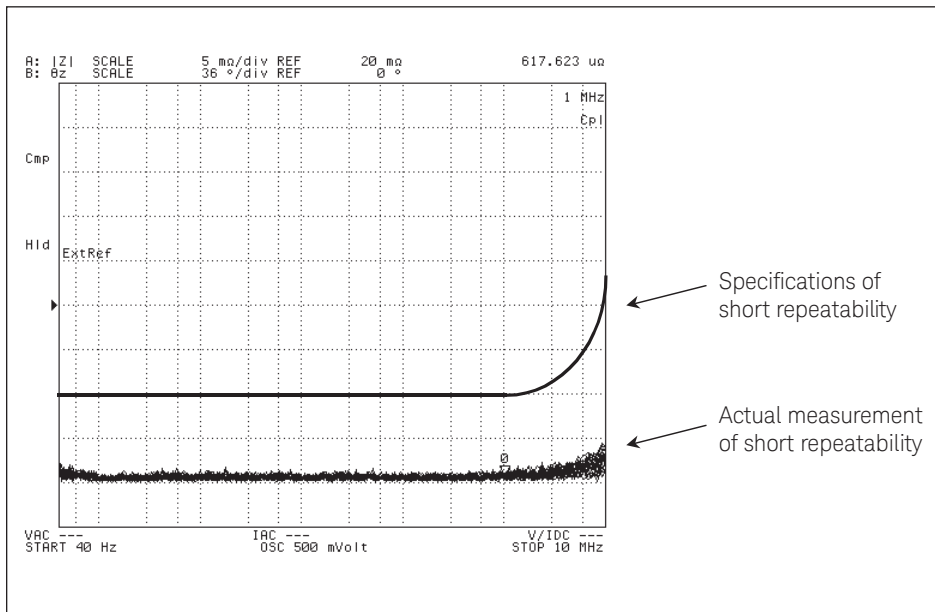


Figure A-6. Measurement of short repeatability (16034G)

Measurement settings

Measurement instrument: 4294A
 Measurement frequency: 40 Hz to 10 MHz
 Measurement parameter: Z - θ
 Compensation: Performed short compensation
 Bandwidth: 3
 Measurement method: Inserted the shorting plate, measure the short condition, and remove the shorting plate. Repeated this 50 times
 Display method: Overlaying traces by using the accumulate mode

Lastly, a method of visually analyzing the accurate measurement range of a test fixture is introduced. This method is only appropriate when all three error-terms (proportional error, open repeatability, and short repeatability) are known. Table A-1 shows the additional error of the 16034G. The whole equation, with all three terms, can be solved for measurement impedance rather than additional error, for example when additional error is equal to 0.5 percent. If the obtained impedance values are plotted with measurement impedance (y-axis) versus frequency (x-axis), a graph similar to the one shown in Figure A-7 can be obtained. The area inside the plotted curve shows the range of impedance that can be measured with an additional error better than 0.5 percent. In the same way, other graphs can be drawn with other additional error values to better visualize the accuracy for a given impedance and frequency range. The operation manuals of recent test fixtures present such graphs.

Table A-1. Additional error of 16034G

Type of error	Impedance
Proportional error	- $0.5 \times (f/10)^2$ [%]
Open repeatability	- $5 + 500 \times (f/10)$ [nS]
Short repeatability	- $10 + 13 \times (f/10)$ [m Ω]

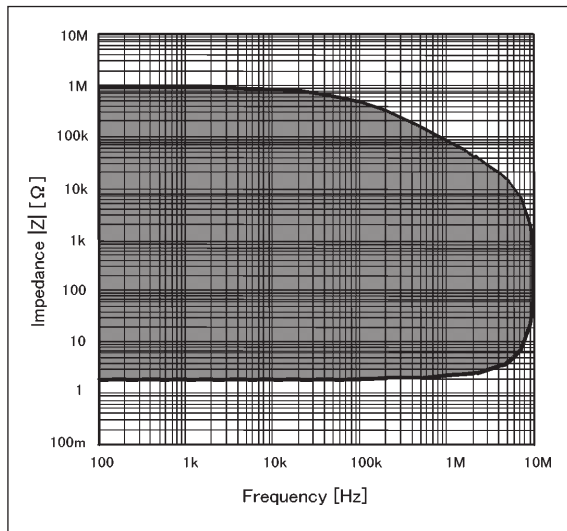


Figure A-7. Range of impedance measurable with additional error \leq 0.5 percent

Appendix B: Open/Short Compensation

The open/short compensation used in Keysight’s instrument models the residuals of a test fixture or test leads as a linear four-terminal network (a two-terminal pair network) represented by parameters A, B, C, and D (shown in Figure B-1.) This circuit model is basically same as that used in open/short/load compensation.

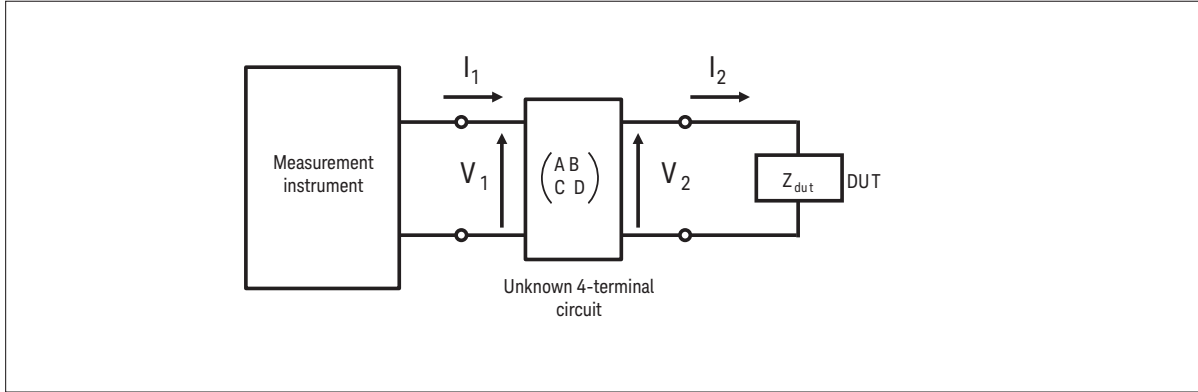


Figure B-1. Four-terminal network circuit model of a test fixture or test cables

The difference between open/short and open/short/load compensation is that the open/short compensation assumes the unknown network as a “symmetrical network.” From this restriction, the open/short compensation does not require the load measurement.

The circuit model shown in Figure B-1 is expressed by using the following matrix equation:

$$\begin{pmatrix} V_1 \\ I_1 \end{pmatrix} = \begin{pmatrix} A & B \\ C & D \end{pmatrix} \begin{pmatrix} V_2 \\ I_2 \end{pmatrix} \quad (1)$$

The relationships between V_1 , I_1 , V_2 , and I_2 are given by the following equations:

$$\begin{cases} V_1 = AV_2 + BI_2 \\ I_1 = CV_2 + DI_2 \end{cases}$$

The measured impedance of the DUT, Z_{xm} , is expressed as:

$$Z_{xm} = \frac{V_1}{I_1} = \frac{AV_2 + BI_2}{CV_2 + DI_2} \quad (2)$$

On the other hand, the true value of the DUT, Z_{dut} , is expressed as:

$$Z_{dut} = \frac{V_2}{I_2} \quad (3)$$

From equations (2) and (3), the equation that expresses the relationship between Z_{xm} and Z_{dut} is derived as follows:

$$Z_{xm} = \frac{AV_2 + BI_2}{CV_2 + DI_2} = \frac{A \frac{V_2}{I_2} + B}{C \frac{V_2}{I_2} + D} = \frac{AZ_{dut} + B}{CZ_{dut} + D} \quad (4)$$

Open measurement

When nothing is connected to the measurement terminals (open condition), I_2 is 0. Therefore, equation (5) is derived by substituting $I_2 = 0$ for I_2 in the equation (2). Here, Z_o means the impedance measured with measurement terminals opened.

$$Z_o = \frac{AV_2}{CV_2} = \frac{A}{C} \quad \therefore C = \frac{A}{Z_o} \quad (5)$$

Short measurement

When the measurement terminals are shorted, V_2 is 0. Therefore, equation (6) is derived by substituting $V_2 = 0$ for V_2 in the equation (2). Here, Z_s means the impedance measured with measurement terminals shorted.

$$Z_s = \frac{BI_2}{DI_2} = \frac{B}{D} \quad \therefore B = DZ_s \quad (6)$$

By substituting $B = DZ_s$ and $C = A/Z_o$ (of equations 6 and 5) for the parameters B and C, respectively, of equation (4), the following equation is derived:

$$Z_{dut} = \frac{B - DZ_{xm}}{CZ_{xm} - A} = \frac{B - DZ_{xm}}{\left(\frac{Z_{xm}}{Z_o} - 1\right)A} = \frac{D(Z_s - Z_{xm})}{\left(\frac{Z_{xm}}{Z_o} - 1\right)A} = \frac{D(Z_s - Z_{xm})}{(Z_{xm} - Z_o)A} Z \quad (7)$$

Since the open/short compensation assumes that the unknown network circuit is a symmetrical network, the parameters A and D are equal:

$$A = D \quad (8)$$

Thus, equation (7) can be simplified as follows:

$$Z_{dut} = \frac{Z_s - Z_{xm}}{Z_{xm} - Z_o} Z_o \quad (9)$$

The definitions of the parameters used in this equation are:

Z_{dut}	Corrected impedance of the DUT
Z_{xm}	Measured impedance of the DUT
Z_o	Measured impedance when the measurement terminals are open
Z_s	Measured impedance when the measurement terminals are shorted

Note: These parameters are complex values that have real and imaginary components.

Appendix C: Open, Short, and Load Compensation

Since a non-symmetrical network circuit is assumed, equation (8) in Appendix B is not applied. Therefore, the relationship between A and D parameters must be determined. The measurement of a reference DUT (load device) is required to determine A and D.

When the applied voltage across a load device is V_2' and the current flow through it is I_2' , the impedance of the load device, Z_{std} , is expressed as:

$$Z_{std} = \frac{V_2'}{I_2'} \quad (10)$$

The measured value of the load device, Z_{sm} , is expressed by using matrix parameters like equation (2) of open/short compensation, as follow:

$$Z_{sm} = \frac{AV_2' + BI_2'}{CV_2' + DI_2'} \quad (11)$$

By substituting Z_{std} for V_2' / I_2' in equation (11), the following equation is derived:

$$Z_{sm} = \frac{AV_2' + BI_2'}{CV_2' + DI_2'} = \frac{A \frac{V_2'}{I_2'} + B}{C \frac{V_2'}{I_2'} + D} = \frac{AZ_{std} + B}{CZ_{std} + D} \quad (12)$$

Using equation (5) of open measurement and equation (6) of short measurement, the relationship between the parameters A and D is expressed by the following equation:

$$Z_{sm} = \frac{AZ_{std} + B}{CZ_{std} + D} = \frac{AZ_{std} + DZ_s}{\frac{Z_{std}}{Z_o} A + D} = Z_o \frac{AZ_{std} + DZ_s}{AZ_{std} + DZ_o} \quad (13)$$

$$\therefore D = \frac{Z_{std}Z_{sm} - Z_{std}Z_o}{Z_oZ_s - Z_{sm}Z_o} A$$

By substituting equation (13) for the parameter D of equation (7), the equation for calculating the corrected impedance of the DUT is derived as follows:

$$Z_{dut} = \frac{D(Z_s - Z_{xm})}{(Z_{xm} - Z_o)A} \quad Z_o = \frac{Z_{std}Z_{sm} - Z_{std}Z_o}{Z_oZ_s - Z_{sm}Z_o} A \times \frac{(Z_s - Z_{xm})}{(Z_{xm} - Z_o)A} Z_o$$

$$Z_{dut} = \frac{(Z_s - Z_{xm})(Z_{sm} - Z_o)}{(Z_{xm} - Z_o)(Z_s - Z_{sm})} Z_{std} \quad (14)$$

The definitions of the parameters used in this equation are:

Z_{dut}	Corrected impedance of the DUT
Z_{xm}	Measured impedance of the DUT
Z_o	Measured impedance when the measurement terminals are open
Z_s	Measured impedance when the measurement terminals are short
Z_{sm}	Measured impedance of the load device
Z_{std}	True value of the load device

Note: These parameters are complex values which have real and imaginary components.

Appendix D: Electrical Length Compensation

A test port extension can be modeled using a coaxial transmission line as shown in Figure D-1. When an impedance element Z_L is connected to the tip of the line, the measured impedance value Z_i at the other end of the line (that is, the test port) is given by the following equation:

$$Z_i = Z_0 \frac{Z_L + Z_0 \tanh \gamma l}{Z_L \tanh \gamma l + Z_0}$$

$$\gamma = \alpha + j\beta = \sqrt{ZY} = \sqrt{(R+j\omega L)(G+j\omega C)}$$

Where, γ : Propagation constant of the transmission line
 α : Attenuation constant of the transmission line
 β : Phase constant of the transmission line
 l : Transmission line length
 Z_0 : Characteristic impedance of the transmission line

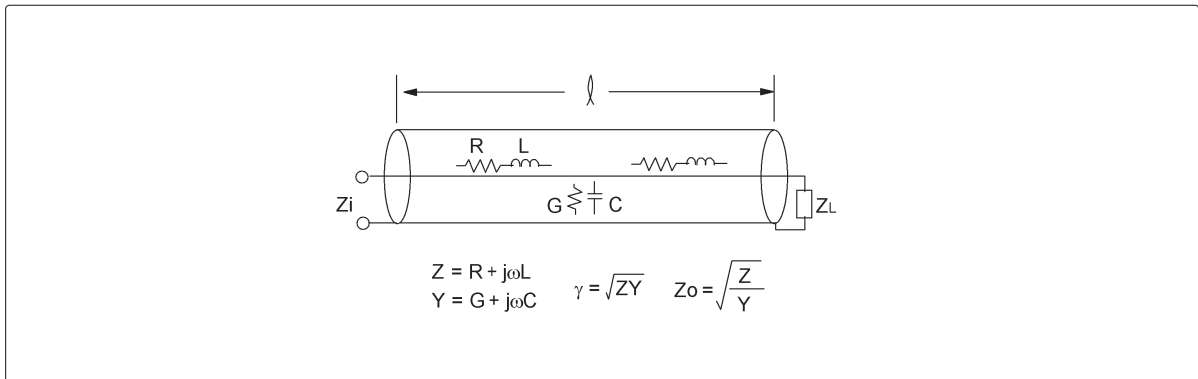


Figure D-1. Transmission line model of test port extension

The DUT impedance value is therefore calculated as:

$$Z_L = Z_0 \frac{Z_0 \tanh \gamma l - Z_i}{Z_i \tanh \gamma l - Z_0}$$

If the transmission line has no propagation loss ($\alpha = 0$, $\beta = \omega\sqrt{LC}$), the equation for Z_L is simplified as follows:

$$Z_L = Z_0 \frac{Z_i - jZ_0 \tan \beta l}{Z_0 - jZ_i \tan \beta l}$$

The true Z_L value can be calculated if the phase shift quantity, βl , is known. Here, the phase constant β is related to the test signal wavelength λ in the transmission line as follows:

$$\beta = \frac{2\pi}{\lambda}$$

When a (virtual) transmission line in which the signal wavelength is equal to the wavelength in a vacuum is assumed, the virtual line length (ℓ_e) that causes the same phase shift ($\beta \ell$) as in the actual line is given by the following equation:

$$e = \frac{\lambda_0}{\lambda} \ell \quad \left(\text{because } \beta \ell = \frac{2\pi \ell}{\lambda} = \frac{2\pi \ell_e}{\lambda_0} \right)$$

Where, λ_0 is a wavelength in vacuum
 λ is a wavelength in transmission line

Therefore, the phase shift quantity, $\beta \ell$, can also be expressed by using the phase constant β_0 in vacuum and the virtual line length ℓ_e (because $\beta \ell = \beta_0 \ell_e$.) Since the β_0 value is derived from physical constants ($\beta_0 = 2\pi/\lambda_0 = \omega/c$, c : velocity of light), it is possible to represent the phase shift by using only the virtual line length ℓ_e .

This virtual line length is specified as the electrical length of the test fixtures and airline extensions. Accordingly, the compensation procedure to derive the impedance Z_L can be simplified by using the electrical length value. In case of the coaxial line, since the β value is proportional to \sqrt{C} (C : distributed capacitance of the line), the electrical length is proportional to the square root of the dielectric constant of the insulation layer between the inner and outer conductors.

Appendix E: Q Measurement Accuracy Calculation

Q measurement accuracy for auto-balancing bridge type instruments is not specified directly as $\pm\%$. Q accuracy should be calculated using the following equation giving the possible Q value tolerance.

$$Q_t = \frac{1}{\frac{1}{Q_m} \Delta D}$$

Where, Q_t is the possible Q value tolerance
 Q_m is measured Q value
 ΔD is D measurement accuracy

For example, when the unknown device is measured by an instrument which has D measurement accuracy of 0.001, and the displayed Q value is 200, the Q tolerance is calculated as:

$$Q_t = \frac{1}{\frac{1}{200} \cdot 0.001} = \frac{1}{0.005 \cdot 0.001}$$

This result means that the true Q value will be between 167 and 250.

Note: The following equation may be used to calculate the Q value tolerance. (The result is the same as that from the above equation.)

$$Q_t = \frac{Q_m^2 \times \Delta D}{1 - (Q_m \times \Delta D)}$$

myKeysight

myKeysight

www.keysight.com/find/mykeysight

A personalized view into the information most relevant to you.

www.keysight.com/go/quality

Keysight Technologies, Inc.

DEKRA Certified ISO 9001:2008

Quality Management System

Keysight Channel Partners

www.keysight.com/find/channelpartners

Get the best of both worlds: Keysight's measurement expertise and product breadth, combined with channel partner convenience.

www.keysight.com/find/impedance



For more information on Keysight Technologies' products, applications or services, please contact your local Keysight office. The complete list is available at: www.keysight.com/find/contactus

Americas

Canada	(877) 894 4414
Brazil	55 11 3351 7010
Mexico	001 800 254 2440
United States	(800) 829 4444

Asia Pacific

Australia	1 800 629 485
China	800 810 0189
Hong Kong	800 938 693
India	1 800 112 929
Japan	0120 (421) 345
Korea	080 769 0800
Malaysia	1 800 888 848
Singapore	1 800 375 8100
Taiwan	0800 047 866
Other AP Countries	(65) 6375 8100

Europe & Middle East

Austria	0800 001122
Belgium	0800 58580
Finland	0800 523252
France	0805 980333
Germany	0800 6270999
Ireland	1800 832700
Israel	1 809 343051
Italy	800 599100
Luxembourg	+32 800 58580
Netherlands	0800 0233200
Russia	8800 5009286
Spain	800 000154
Sweden	0200 882255
Switzerland	0800 805353
	Opt. 1 (DE)
	Opt. 2 (FR)
	Opt. 3 (IT)
United Kingdom	0800 0260637

For other unlisted countries:
www.keysight.com/find/contactus
(BP-09-23-14)