

Agilent Technologies Considerations for Instrument Grounding

Application Note

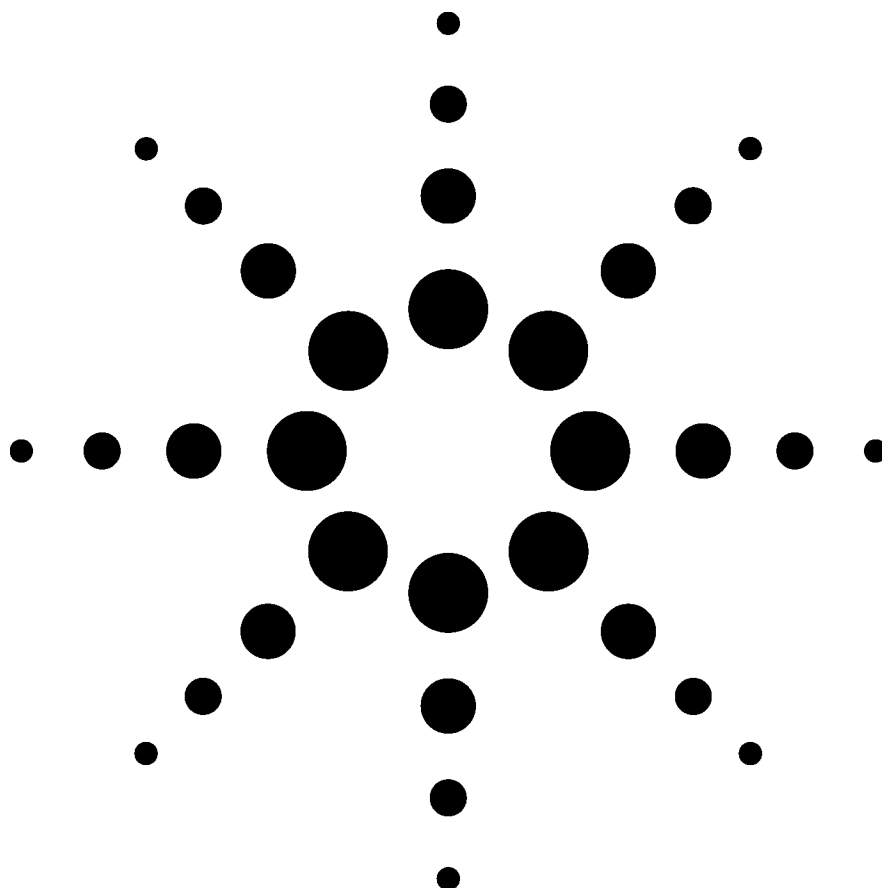

Kuo Yen-Lung

Agilent Technologies Taiwan

Many people have heard of the term “grounding”, but few fully understand its meaning and importance. Sometimes, even experienced electricians do not treat grounding as a serious issue. The impact of an incorrect or absent grounding ranges from noise interference, resonance or humming during the use of electrical equipment to the worst case where electricity leakage through the chassis causes personal injury or damage to instrument components. Grounding, therefore, is a very practical issue that should be dealt with properly. For those who operate electrical equipment frequently, a complete understanding of grounding theories and applications is necessary in order to become a best-in-class technician.

In the eighteenth century, Benjamin Franklin performed the famous kite experiment to observe how lightning in the sky was conducted to the earth. This experiment led to the invention of lightning rods to avoid lightning strikes. From then on, people began to realize that the vast ground under our feet is a huge electrical conductor. It may not be the best conductor, but it is certainly a good one. It is so enormous in size that it can sustain a tremendous amount of current. That is why the voltage level of the ground is set to be zero. Safety regulations require that all metal parts which do not carry electricity should be kept at zero or the earth voltage level.

There are several reasons for grounding. Some are for safety purposes, and some are for maintaining circuit stability. The following are some examples:

1. Power system grounding: As you can see in Figure 1, this design is to prevent the secondary side from being damaged by the high voltage on the primary side, as the current will be conducted to the ground through the Grounding Wire to protect human lives.

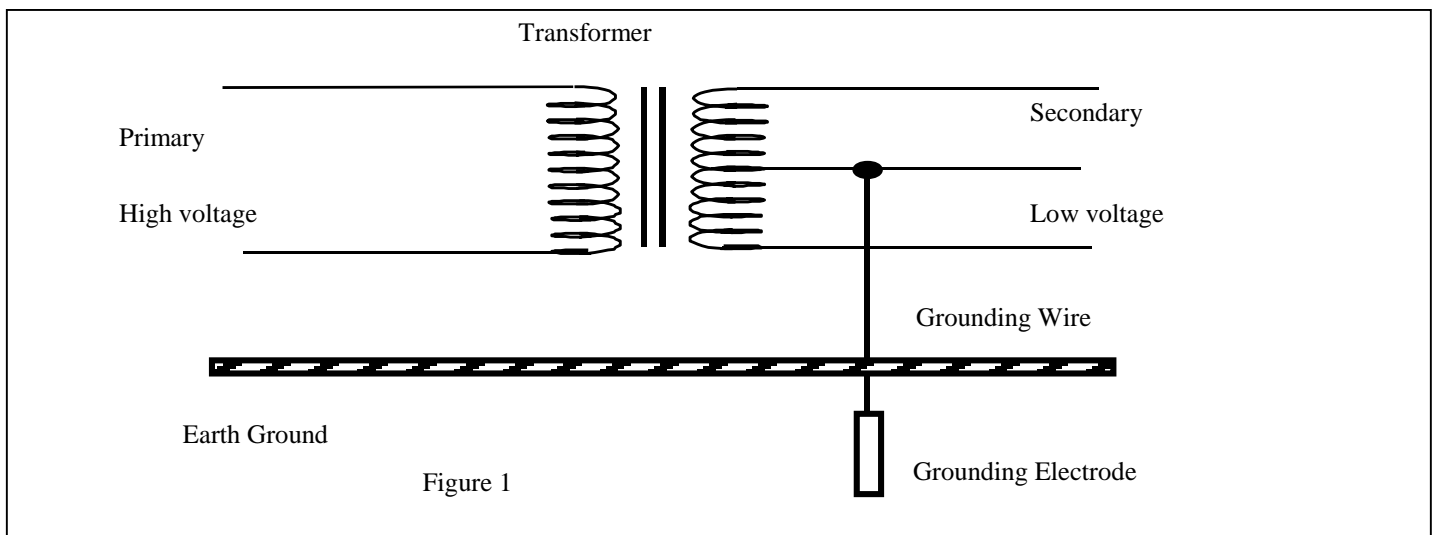

2. Instrument grounding: By connecting the equipment or chassis to the ground, operators can be protected from electric shocks if there is electricity leakage.
3. Signal grounding: A zero voltage reference or a loop-back path is provided for all integrated signals to ensure proper functioning or accurate measurements.
4. Shielded grounding: This is used to prevent static electricity from being accumulated. Ground isolation or conduction can help to reduce noises and electro-magnetic interference. Examples include shielding rooms, cables, wirelines, guarded terminals of instruments, transformers and filters.

Types of Instrument Grounding

- (1) Figure 2 shows a commonly used instrument grounding on inputs and AC power. In this case, the input signal ground is connected to the power ground and when you are making a measurement, it is important to make sure that the input signal ground is not short-circuited directly to any point where there is a voltage difference to the earth ground. This is very common when measuring commercially available low-cost circuits. To reduce costs, these circuits usually do not use power-isolated transformers. Instead, the AC power is directly connected to the circuit. As a result, a loop is formed between the circuit itself and the earth ground, and a voltage difference occurs. If the AC power happens to be plugged in the reverse way, or a considerable voltage difference exists between the neutral line and the earth ground, the combined factors could lead to very unpredictable results. Therefore, caution must be exercised before the input is connected for measurement.

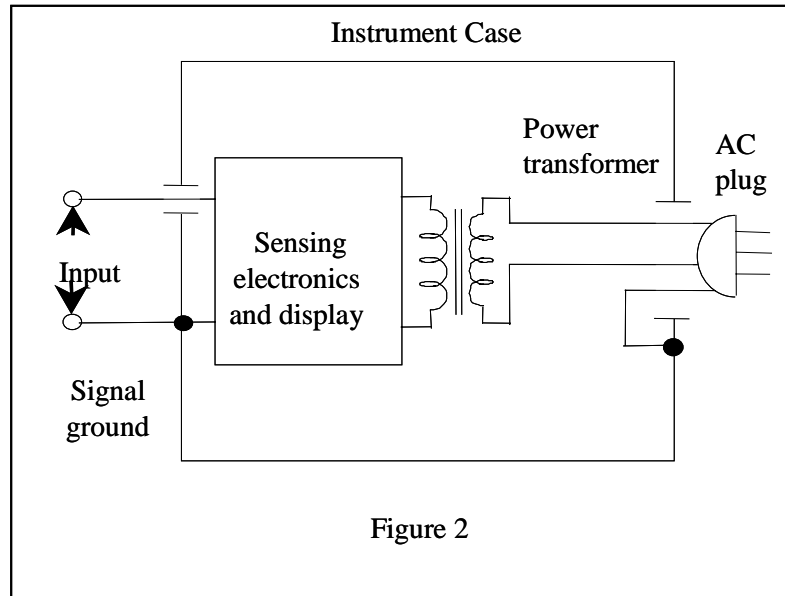

- (2) To avoid the problem described above, some instruments provide floating inputs as shown in Figure 3. Each of the inputs is floating from the earth ground. Ideally, as long as the voltage difference between these two inputs is within an acceptable range, the inputs can be connected to any voltage point.

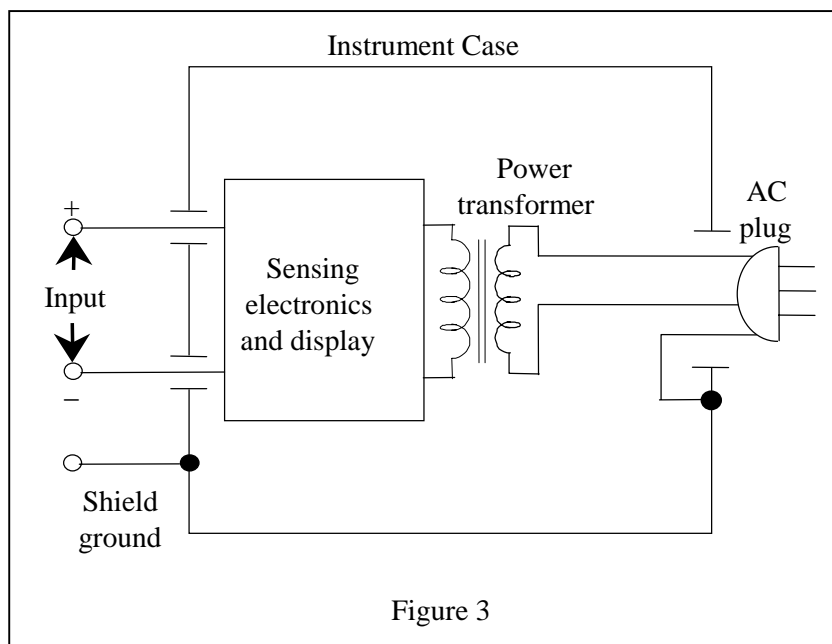

- (3) Figure 4(a) and 4(b) show some common instruments for output devices. For DC or low frequency generators, the design shown in 4(a) is usually adopted, while for high frequency (RF) generators, the model in 4(b) is used. Therefore, special attention is required to avoid the problem described in item (1) when performing a high frequency measurement. Otherwise, the voltage difference and conflict may cause damage to the input and output of instrument circuits.

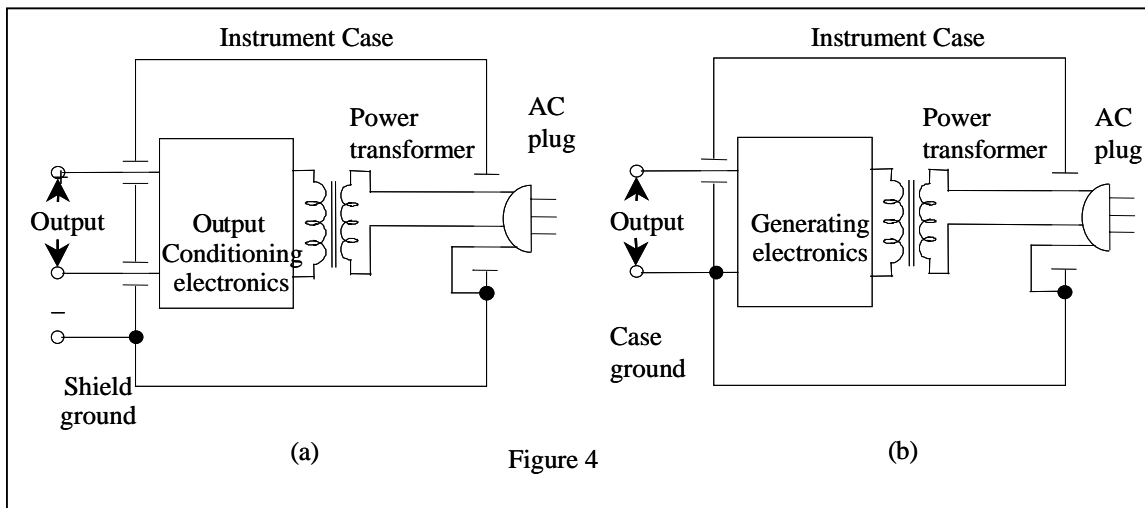

Guidelines for Instrument Grounding

While there are some guidelines for grounding, there is no hard and fast rule. In practice, it is difficult to follow all the guidelines. Rather, it is dependent on the environment and applications. For instance, before the measurement is performed, evaluations should be made to decide whether the floating method should be used. The following are some general guidelines:

- (1) When dealing with different kinds of grounding such as shielded grounding, power grounding and signal grounding, make sure that they are guided to their own paths to avoid interaction.
- (2) Keep the impedance of the ground line low and the path short.
- (3) Avoid multiple ground loops, which may disturb current flows.

- (4) Isolate the heavily loaded ground current loop from the small signal loop.

Let's take a look at the example in Figure 5. For a well-designed power supply equipment, the voltage ripple between output A and B should be very small. However, if for convenience sake, point C instead of point D is used as the signal's ground reference, a significant pulse voltage will occur and show up on the output circuit even when the resistance between point C and D is small. This is because the transient current in charging or discharging the capacitors is usually very high. As a result, as soon as the power is on, damage can be caused to the connected circuits or instruments.

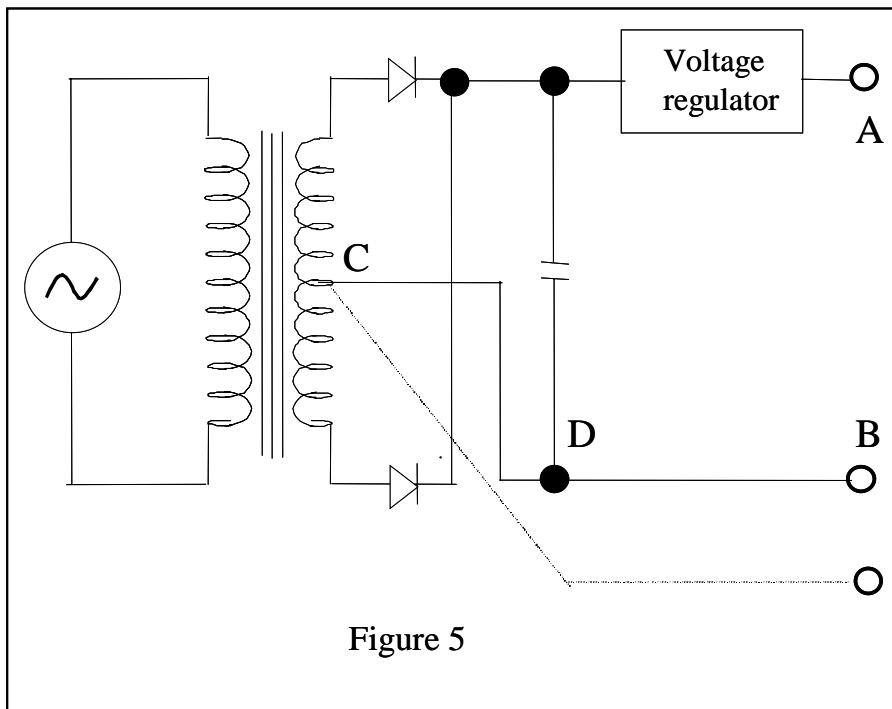

Common Causes of Poor Grounding

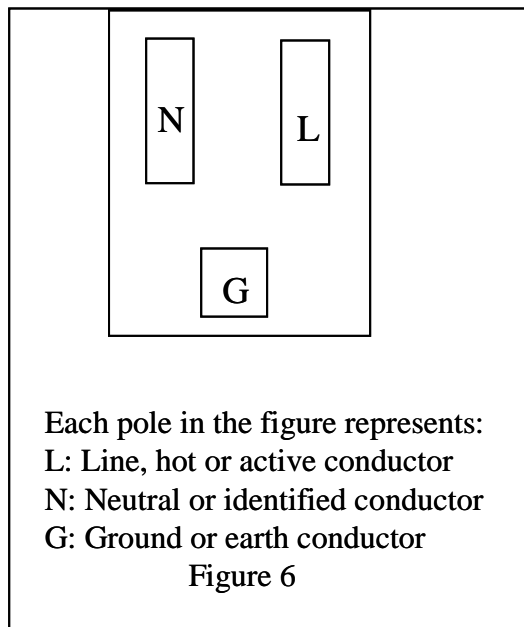

- (1) The AC power (such as 110V) socket does not provide the ground line (green), as shown in Figure 6. The earth pole on the plug is usually the longest, so that it can be connected to the ground first when the AC power is plugged into the socket.
- (2) The actual impedance to the ground is too high which does not comply with electrical regulations (please refer to the appropriate regulations in your country). Take the example of the third type of grounding . When the AC voltage to the ground is above 300V, the impedance to the ground must be less than 10Ω . If the AC voltage to the ground is under 150V, the impedance to the ground should be within 100Ω .
- (3) The neutral line is mistakenly used as the ground line and these two lines are short-circuited together on the socket. Under normal conditions, the voltage difference between the neutral line and the ground line on the socket must be within 1.0V, but this should not be accomplished by short-circuiting these two lines together.
- (4) Swap the hot line and the neutral line arbitrarily. Take Figure 7 as an example. Equipment A sends out signals while equipment B receives signals. Suppose the AC power sockets to which Equipment A and B

are connected do not provide the ground line, and the hot line and neutral line are swapped on one of the equipment. Since equipment A and B both have noise filters installed, a 110V AC loop is therefore formed accidentally even when the power of A and B is not connected.

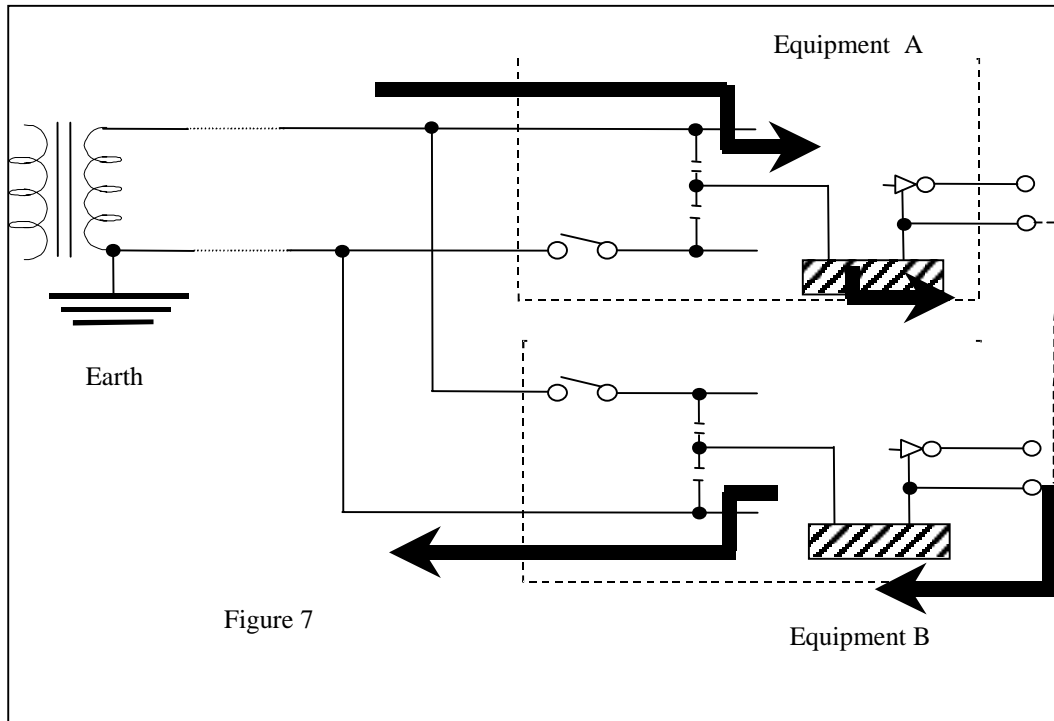

Summary

- (1) When installing the equipment in a building, make sure to have an electrician check on the impedance to the ground and the grounding device to see if they comply with electrical regulations. 8AWG wireline should be used as a minimum wire type for instrument grounding.
- (2) Use the three-pole AC power socket for the instrument. Make sure the polarity of the hot line and the neutral line is correct (see Figure 6). The voltage difference between the neutral and the ground lines should be less than 1V. At the socket end, the impedance between the neutral and the ground lines should be lower than 1Ω .

- (3) Find out the appropriate way to do measurements, i.e. whether the instrument 's input/output terminals should be grounded or be floating.
- (4) Check the stability of the AC power (+5% to –10% within 120V) and whether there are unpredictable impulses, which may cause the measurement to fail or even damage the instrument. Generally, the transient voltage fluctuation should not exceed $\pm 15\%$ within 120V and the voltage should be restored to 120V within 0.5 second. The total harmonic component should be less than 5%.
- (5) Verify the grounding of the equipment or device under test (DUT) . If voltage differences exist among equipment, connecting them together may cause conflicting situations. The sudden pulses generated when the equipment is powered on may also damage vulnerable modules. If this happens, the links between the equipment and devices under test should be disconnected before the AC power is turned on. Each equipment and DUT should be reconnected only after all equipment and devices have stabilized. In so doing, the possibilities of damage can be minimized. However, this is not the way to eradicate the problem completely . The best solution is to identify the root causes and fix them.
- (6) Reduce and remove unwanted static, interference and noise through proper grounding.

Agilent Technologies Test & Measurement Service Centers have been providing comprehensive and precise repair and calibration services to customers for many years. Our pursuit of quality and technical innovation enables us to offer better services to our customers. By sharing this article with you, we hope to help you improve the accuracy of measurements and the life span of your instruments.